



Compatible with National Semiconductor's Simple Switcher™  
Part Number's LM2574, LM2475 and LM2576

**Features**

- High energy storage with minimum saturation
- High stability from no load to full load
- Available in both SMD and TH versions
- Manufactured in ISO-9001 approved facility
- Operating temperature range: -40°C to +125°C



**Electrical Specifications at 25°C ambient**

Part Number	Rated Current (I <sub>DC</sub> )	L <sub>N</sub> (μH) Typical *	L <sub>O</sub> (μH) ±20% No DC Load	ET <sub>OP</sub> (V-μSec) Max.	DCR (Ohms) Max.	Package					
						"C"	"S"	"T"	"B"	"F"	"V"
SW_-3.0-47	3.0	47	38	90	0.05	2	5	5			
SWC-3.0-68	3.0	68	55	90	0.02	4					
SWC-3.0-100	3.0	100	91	90	0.04	4					
SW_-2.0-150	2.0	150	130	90	0.10	4	6				
SW_-1.4-220	1.4	220	230	90	0.38		5	5		2	2
SW_-1.4-220	1.4	220	176	90	0.14	3	6				
SW_-0.9-330	0.9	330	302	90	0.74		5	5		2	2
SW_-0.9-330	0.9	330	267	90	0.18	3	6				
SWC-0.64-470	0.64	470	426	90	0.16	4					
SW_-0.85-680	0.85	680	657	90	1.25		5	5		2	2
SWC-3.0-150	3.0	150	136	200	0.10	4					
SWC-3.0-220	3.0	220	167	200	0.07	5					
SWC-3.0-330	3.0	330	292	200	0.15	5					
SWC-2.0-470	2.0	470	369	200	0.17	5					
SWC-1.3-680	1.3	680	562	200	0.20	5					
SWC-0.95-1000	0.95	1000	762	200	0.24	5					
SWB-0.62-1500	0.62	1500	1150	200	1.00				8		
SWB-0.42-2200	0.42	2200	1730	200	1.80				8		

**Notes:**

- 1) Inductance will be typical for the I<sub>DC</sub> and ET<sub>OP</sub> values listed above.
- 2) No load Inductance measured at B<sub>OP</sub> maximum of 10 gauss (10mV @ 20kHz).
- 3) Simple Switcher™ is a trademark of National Semiconductor Corporation.

**Ordering Key**

**SW C - 3.0 - 47**

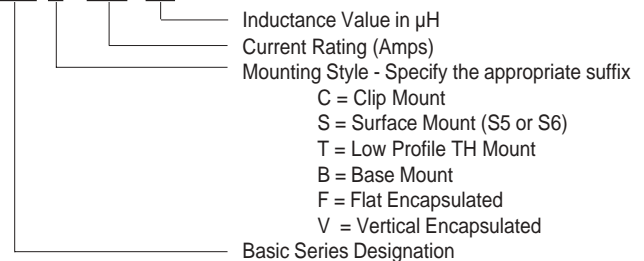

# Mounting Styles • SW Series - Low Cost Toroidal Inductors

**Type "B" - Vertical Mount**

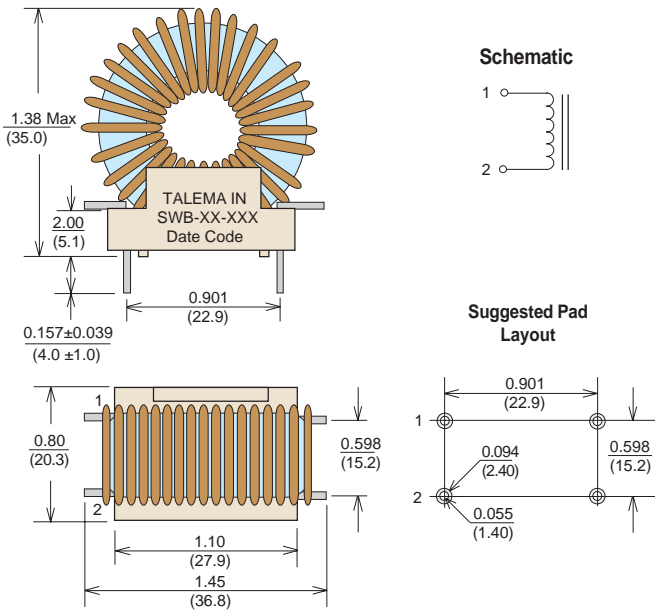

**Type "V" - Vertical Mount - Size 2**

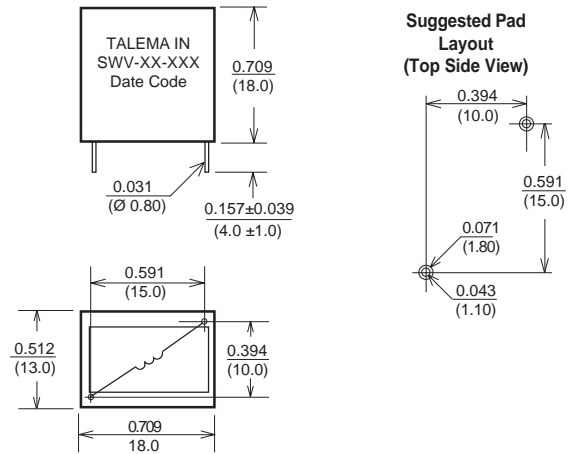

**Type "F" - Flat Mount - Size 2**

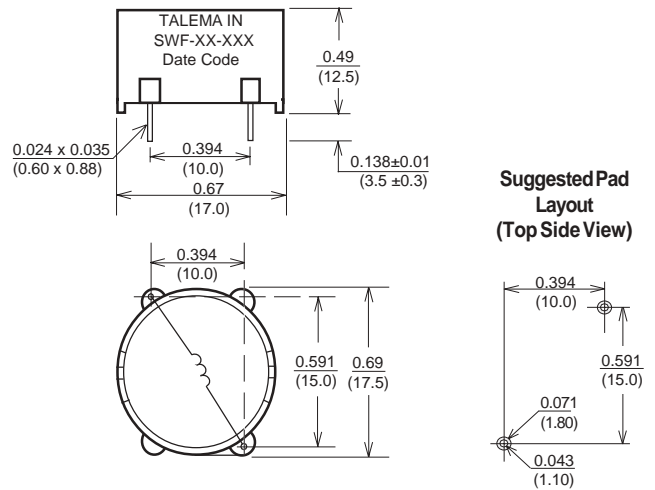

**Type SWT - Through Hole Mount**

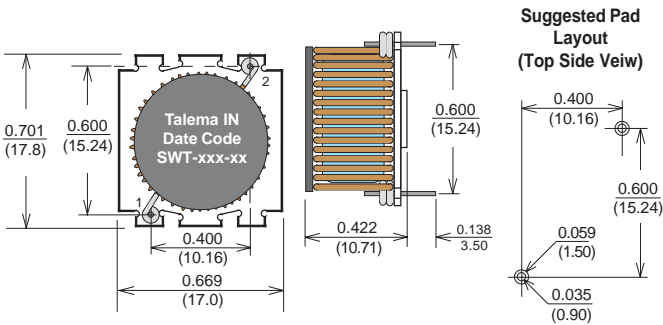

**Type SWS - Surface Mount**

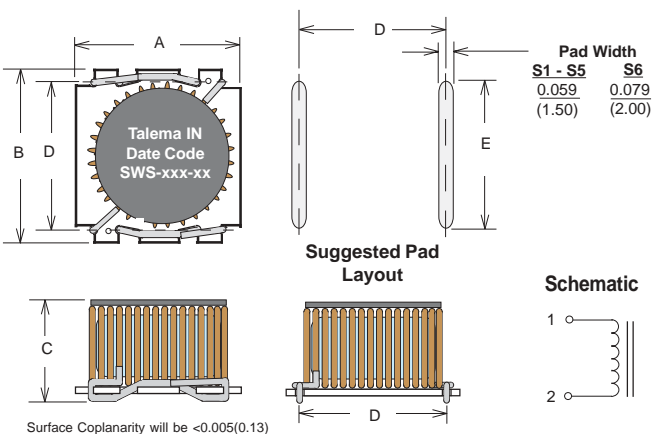

**Type SWC - Clip Mount**

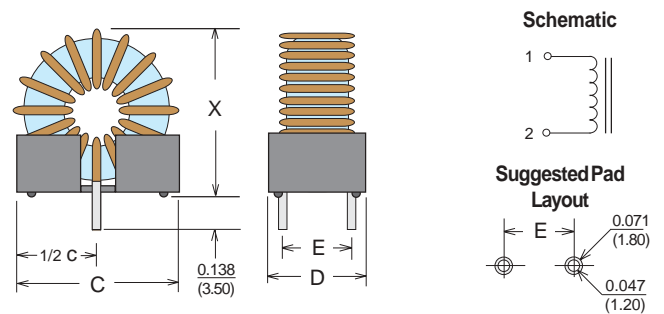

Mounting Style	Size Code	Dimensions - Inches (mm)				
		A	B	C	D	E
"S" SMD	S5	0.669 (17.0)	0.701 (17.8)	0.425 (10.8)	0.591 (15.0)	0.591 (15.0)
	S6	0.925 (23.5)	0.925 (23.5)	0.531 (13.5)	0.827 (21.0)	0.689 (17.5)

Mounting Style	Size Code	Dimensions - Inches (mm)			
		C	D	E	X = Coil O.D. +
"C" Vertical Clip Mount	C2	0.650 (16.5)	0.449 (11.4)	0.299 (7.60)	0.110 (2.80)
	C3	0.827 (21.0)	0.449 (11.4)	0.299 (7.60)	0.110 (2.80)
	C4	0.949 (24.1)	0.598 (15.2)	0.449 (11.4)	0.110 (2.80)
	C5	1.252 (31.8)	0.701 (17.8)	0.500 (12.7)	0.130 (3.30)



Pulse Engineering - Talema

Pulse Eng. Part Number	Talema Part Number*					
	Vertical Clip Mount	Flat Open SMD	Flat Open TH	Vertical TH Base Mount	Flat TH Encapsulated	Vertical TH Encapsulated
PE-53112	SWC-3.0-47	SWS-3.0-47	SWT-3.0-47			
PE-92114K	SWC-3.0-68					
PE-92108K	SWC-3.0-100					
PE-53113	SWC-2.0-150	SWS-2.0-150				
PE-52626		SWS-1.4-220	SWT-1.4-220		SWF-1.4-220	SWV-1.4-220
PE-53145	SWC-1.4-220	SWS6-1.4-220				
PE-52627		SWS-0.90-330	SWT-0.90-330		SWF-0.90-330	SWV-0.90-330
PE-53146	SWC-0.90-330	SWS6-0.90-330				
PE-53114	SWC-0.64-470					
PE-52629		SWS-0.85-680	SWT-0.85-680		SWF-0.85-680	SWV-0.85-680
PE-53115	SWC-3.0-150					
PE-53116	SWC-3.0-220					
PE-53117	SWC-3.0-330					
PE-53118	SWC-2.0-470					
PE-53119	SWC-1.3-680					
PE-53120	SWC-0.95-1000					
PE-53121				SWB-0.62-1500		
PE-53122				SWB-0.42-2200		

\*Note: There are no equivalent Pulse SMD types for Talema P/N SWT-3.0-47 and the SWS style SMD package.

Sales & Marketing, Design and Manufacturing Facilities

<http://www.talema-Nuvotem.com>

**Eastern Europe & Czech Republic**

NT MAGNETICS s.r.o.  
Chebská 27  
322 00 Plzeň  
Tel: Int. + 420 37 - 744 9303  
Fax: Int. + 420 37 - 744 3697  
Email: talema@talema.cz

**Germany**

TALEMA ELEKTRONIK GMBH  
Sembdnerstr. 5, Postfach 2523  
82110 Germering  
Tel: Int. + 49 89 - 841 00 - 0  
Fax: Int. + 49 89 - 841 00 25  
Email: info@talema.de

**Ireland**

NUVOTEM TEO.  
Crolly  
Co. Donegal  
Tel: Int. + 353 74 - 954 8666  
Fax: Int. + 353 74 - 954 8139  
Email: info@nuvotem.com

**India**

TALEMA ELECTRONIC PVT. LTD.  
Opposite the SIDCO Industrial Estate  
Gins Towers  
4/5S.H/1, Omalur Main Road  
Salem - 636 004, Tamil Nadu  
Tel: Int. + 91 427 - 244 1325  
Fax: Int. + 91 427 - 243 0034  
E-mail: talema@talemaindia.com