

AS2701A (ISA3+)

AS-Interface Slave IC

Data Sheet

Rev. C, October 2000

Key Features

- Simple two-wire bus (AS-Interface line)
- Transmission of both power and signal on the AS-Interface line
- Decoupling of power and signal by the IC without additional external devices
- Transmitting protocol for using the IC and the AS-Interface master in the transmit/receive modes
- Switching of max. 31 AS-Interface slave ICs on one bus possible
- Power supply of peripheral devices from the AS-Interface slave IC of up to 35mA@24V
- Only few external devices necessary for operation (quartz, 4 capacitors, E²PROM)
- Storing of the configuration data and the slave address in one E²PROM
- Quartz oscillator for 5.333 MHz without external capacitances
- Standards: AS-Interface–Spec V2.0 and EN 50295

General Description

The signal transmission between the master and the slaves in the AS-Interface system is performed by a parallel two-line wire (AS-Interface line) to which the IC is connected only via a polarity protection diode and a suppressor diode. The line is powered by a direct dc voltage of up to 33.1 V, on which data pulses with signal amplitudes of (3...8) V_{pp} are superimposed. The IC extracts its own power and the power for peripherals from the line and detects the bus signals.

The AS-Interface slave IC consists of the following blocks:

- Receive Block
- Transmit Block
- Digital Logic Block
- Emergency Control Block
- Internal and External Power Supply with Signal decoupling
- Oscillator
- Power on Reset
- High Voltage I/O

Block Diagram

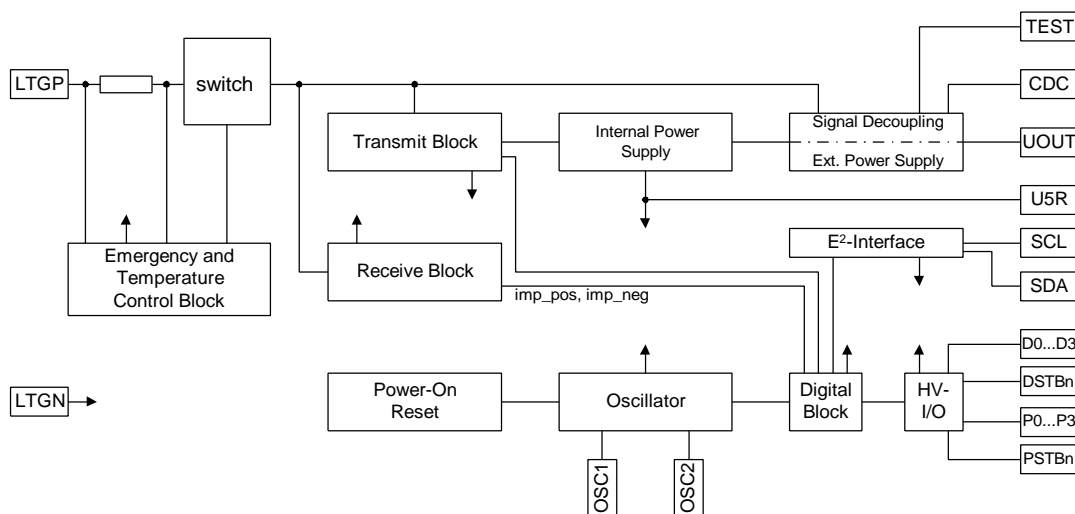

Package

SOIC20

Pin Description

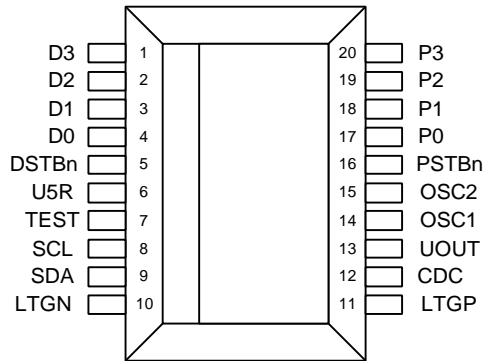

Pin	Name	Type	Description
1	D3	I/O	Data input/output 3, configurable
2	D2	I/O	Data input/output 2, configurable
3	D1	I/O	Data input/output 1, configurable
4	D0	I/O	Data input/output 0, configurable
5	DSTBn	I/O	Strobe output for the data port, input for a reset signal (active low)
6	U5R	Voltage OUT	Supply voltage of the E ² PROM, Blocking capacitor CU5R
7	TEST	IN	Connection to the capacitor CTEST
8	SCL	OUT	Serial two-wire bus, puls wire
9	SDA	I/O	Serial two-wire bus, address and data wire
10	LTGN	SUPPLY	AS-Interface wire, negative supply
11	LTGP	SUPPLY	AS-Interface wire, positive supply
12	CDC	Voltage OUT	Blocking capacitor CCDC
13	UOUT	Voltage OUT	Peripherals
14	OSC1	IN	Quartz connection
15	OSC2	OUT	Quartz connection
16	PSTBn	OUT	Strobe output for the parameter port, test mode (without importance for users)
17	P0	OUT	Parameter output 0
18	P1	OUT	Parameter output 1
19	P2	OUT	Parameter output 2
20	P3	OUT	Parameter output 3

Functional Description

The IC identifies and decodes the supply voltage overlapping signals of the master telegram. If the slave address contained within the master telegram coincides with the stored information in the E²PROM of the slave address, the corresponding master command of the addressed AS-Interface slave IC is executed.

After decoding of the master telegram the addressed AS-Interface slave IC responds with a corresponding slave answer on the AS-Interface line.

The AS-Interface slave IC extracts its own supply voltage and the supply voltage for the E²PROM from the AS-Interface line. At the same time, the IC provides a direct voltage for the peripheral UOUT which results from $U_{LTGP} - U_{DROF}$ for a maximum current of 35 mA.

The receive block detects the signal on the AS-Interface wire LTGP. The reference voltages of the signal comparators are $(52.5 \pm 5) \%$ of the maximum signal value and are controlled by a peak value detector in the following mode: The comparator level is set to its default value by Reset or if a non-correct signal is received.

If a line pause is detected, the level reset is released and the IC is able to adapt itself to different signal levels. If the IC is not synchronized yet, the level adaption is faster (smaller attack and decay time constants) as in the synchronous case.

The output information of the receive blocks are the signals: "imp_pos" and "imp_neg".

The transmit block drives the output level for the modulated transmit signal edges. The transmit block consists of the NMOS transistor (transmit transistor), DAC for transmit signal formation and a Jabber-Inhibit Circuitry. The DAC is addressed by the digital block. If the transmitter is active more than typ. 300µs the Jabber-Inhibit circuit separates the IC from the AS-Interface line. This condition can only be left by a Power-On-Reset.

In the digital block the received signal is analyzed, the transmit signal is generated and the data and parameter ports as well as the E²PROM interface are driven. The E²PROM interface acts as a serial two-wire interface with the following transmission streams:

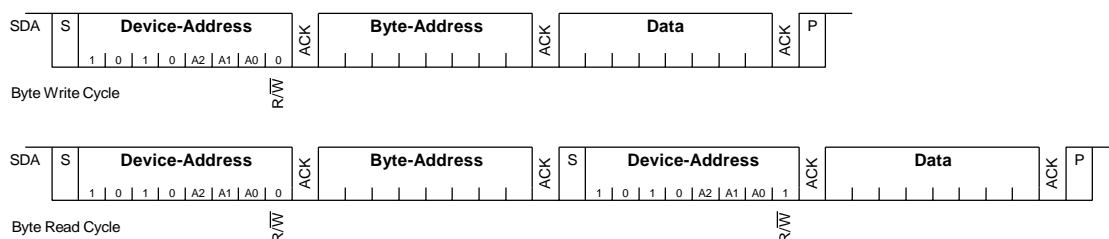

After the AS-Interface slave IC has sent the START condition, the device address is transmitted. This address would allow the selection of a maximum of 8 possible E²PROM ICs, is however fixed to 000 by the AS-Interface slave IC. Therefore in the application pins AO...A2 of the E²PROM are connected to Uss.

Write Cycle

After the device address, the write cycle $\overline{R/W}$ -Bit=0, necessary for the identification of the write cycle, is sent. The E²PROM acknowledges the correct receipt with the acknowledge bit ACK. Then the data byte which should be written into the E²PROM reacknowledges with an ACK signal of the E²PROM. The STOP condition ends the cycle.

Read Cycle

The read cycle is similar to the herein described write cycle. In this case the $\overline{R/W}$ -Bit = 1 which causes the E²PROM to place read data for the received Byte address on the bus after the acknowledge.

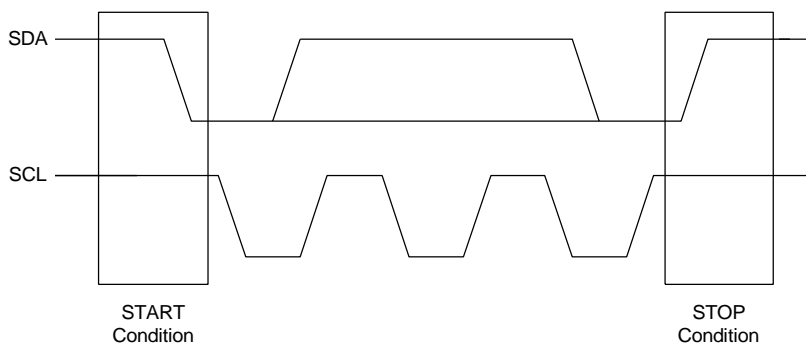

The **START condition** is recognized by the E²PROM when a H/L edge arises on the dataline SDA during the high phase of the clock.

The **STOP condition** is present when a L/H edge arises on the dataline SDA during the high phase of the clock SCL. The timing of the E²PROM interface is derived from the AS-Interface quartz frequency of 5.333 MHz.

Functional, electrical and timing characteristics

All voltages are referenced to LTGN = 0V, timing is valid for a clock frequency of 5.333 MHz.

a) Absolute Maximum Ratings

Symbol	Parameter	Min	Max	Unit	Note
VLTGP	Positive Voltage	- 0.3	40	V	1
VLTGPOV	Positive Impulse Voltage		50	V	2
Vin1	Voltage at D0...D3, P0...P3, DSTBn, PSTBn, CDC, UOUT, TEST	VLTGN - 0.3	VLTGP + 0.3	V	Vin ≤ 40V
Vin2	Voltage at OSC1, OSC2, SDA, SCL, U5R	VLTGN - 0.3	7	V	
Iin	Input Current on every Pin	-25	25	mA	
H	Non-Condensated Humidity				3
ESD	Electrostatic Discharge		1000	V	4
θSTG	Storing Temperature	-55	125	°C	
θlead	Soldering Temperature		260	°C	5
Ptot	Power Dissipation		1	W	6
Notes:					
1 A polarity protection diode is to be used externally					
2 Impulse width: ≤ 50 μs; repetition rate: ≤ 0.5 Hz					
3 Defined in DIN 40040 cond. F					
4 HBM; R = 1.5 kΩ; C = 100pF					
5 260 °C for 10 s (reflow and wave soldering), 360 °C for 3 s (manual soldering)					
6 SOIC 20: Rthja = 64.5 °K/W typ.					

b) Recommended Operating Conditions

Symbol	Parameter	Min	max	Unit	Note
VLTGP1	Positive Voltage	26.9	33.1	V	1
VLTGP2	Positive Voltage for Sensor Applications	17.5	33.1	V	2
ILTG	Operating Current @ VLTG = 30 V		6	mA	3
IOL	Max. Operating Current @ D0...D3, DSTBn		10	mA	
IOL	Max. Output Current @ P0...P3, PSTBn		6	mA	
fC	Quartz Frequency	5.333		MHz	4
θamb	Operating Temperature	-25	85	°C	
Notes:					
1 DC Parameter; VLTGP1min = VUOUTmin + VDROPMAX; VLTGPmax = VUOUTmax + VDROPMIN					
2 DC Parameter; VLTGP2min = VCOMOFFmax + VDROPMAX					
3 fC = 5.333 MHz, no load on UOUT and U5R, IC in idle mode					
4 "AS-Interface-Quartz"					

c) Power Supply Pins LTGP and LTGN (LTGN = 0 V-reference)

The AS-Interface Slave IC's input at LTGP behaves as if a resistor R_P and a (non-linear) parallel capacitor C_P connect LTGP to LTGN.

LTGP input impedance over frequency is as follows:

RP	CP	F
$\geq 10 \text{ k}\Omega$	$\leq 35 \text{ pF}$	50 kHz
$\geq 10 \text{ k}\Omega$	$\leq 45 \text{ pF}$	100 kHz
$\geq 10 \text{ k}\Omega$	$\leq 48 \text{ pF}$	125 kHz
$\geq 10 \text{ k}\Omega$	$\leq 51 \text{ pF}$	160 kHz
$\geq 10 \text{ k}\Omega$	$\leq 54 \text{ pF}$	200 kHz
$\geq 10 \text{ k}\Omega$	$\leq 60 \text{ pF}$	300 kHz

d) Data and Parameter Ports (D0...D3, DSTBn; P0...P3, PSTBn)

These pins are equipped with both an input and output channel as well as a current source based pull-up structure; the I/O-circuit at these pins and their DC-characteristics @ output channel 'Off' are described below.

The AS-Interface slave system concept requires D0...D3 and DSTBn to be bidirectional pins and P0...P3 and PSTBn to be outputs.

The input channel on pins P0...P3 and PSTBn is only implemented to simplify the AS-Interface Slave IC's device test, and is not intended to be used in AS-Interface Slave system applications.

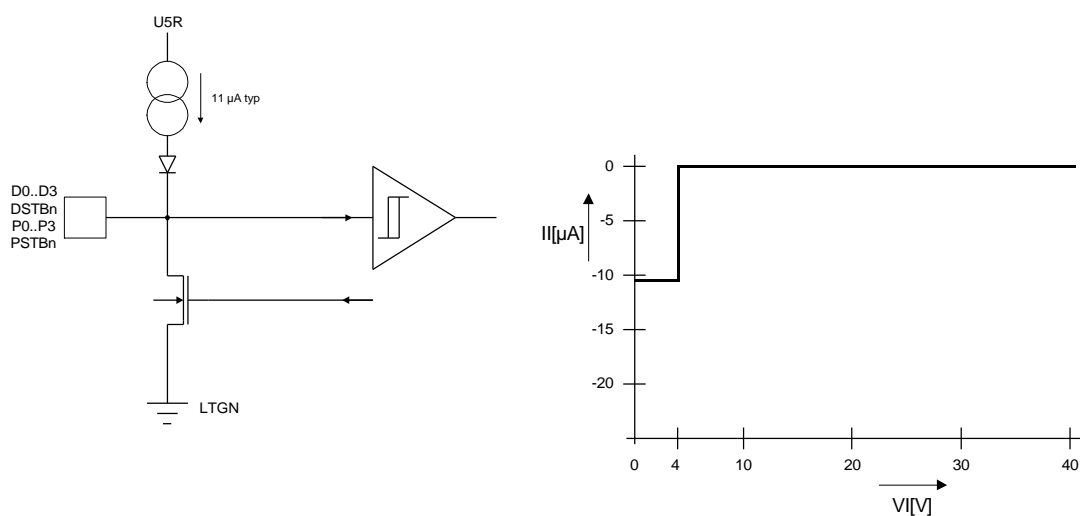

Symbol	Parameter	min	max	Unit	Note
VIL	Input Voltage "Low"	0	1.5	V	
VIH	Input Voltage "High"	3.5	VUOUT	V	
VHYST	Input Hysteresis	0.25	0.5	V	1
VOL11	Output Voltage	0	1	V	IOL11 = 10mA D0...D3, DSTBn
VOL12	Output Voltage	0	1	V	IOL12 = 6mA P0...P3, PSTBn
VOL2	Output Voltage	0	0.4		IOL2 = 2mA
IIL	Input Current	-20	-5	µA	VIL = 1V, Output "off"
IIH	Input Current	-10	10	µA	VU5R ≤ VIH ≤ 40V Output "off"
CDL	Loading Capacitance on DSTBn		10	pF	2

Notes:

- 1 Switching points approx. 2.5 V, i.e. $2.5\text{ V} \pm \text{VHYST}$
- 2 For larger capacitive loads an external Pull-Up-Resistor to UOUT must be used, so that the beginning of the DSTB = LOW impulse of $\text{VIH} \leq 3.5\text{ V}$ to DSTBn is reached in less than 35 µs, otherwise a reset is the result.

Timing characteristics

Symbol	Parameter	min	max	Unit	Note
t _{DSTBL}	DSTBn to D0...D3, Direction OUT, Output Data LOW		1	µs	
t _{DSTBH}	DSTBn to D0...D3, Direction OUT, Output Data HIGH		1.5	µs	
t _{DATA}	DSTBn to D0...D3, High Resistive	6.2	7	µs	1
t _{DSTB}	DSTBn Pulse Width	6	6.8	µs	
t _{DINon}	DSTBn to D0...D3, Direction IN, Valid Input Data	6.5	7.7	µs	
t _{DINoff}	DSTBn to D0...D3, End of Direction IN	12.5	t _{CYCLE}	µs	
t _{CYCLE}	Next Cycle	150		µs	
t _{ALM1}	Extension DSTBn to D0...D3, High Resistive		44	µs	
t _{ALM2}	Extension DSTBn (No Reset)	35		µs	

Note 1: Data valid until DSTBn L/H-edge

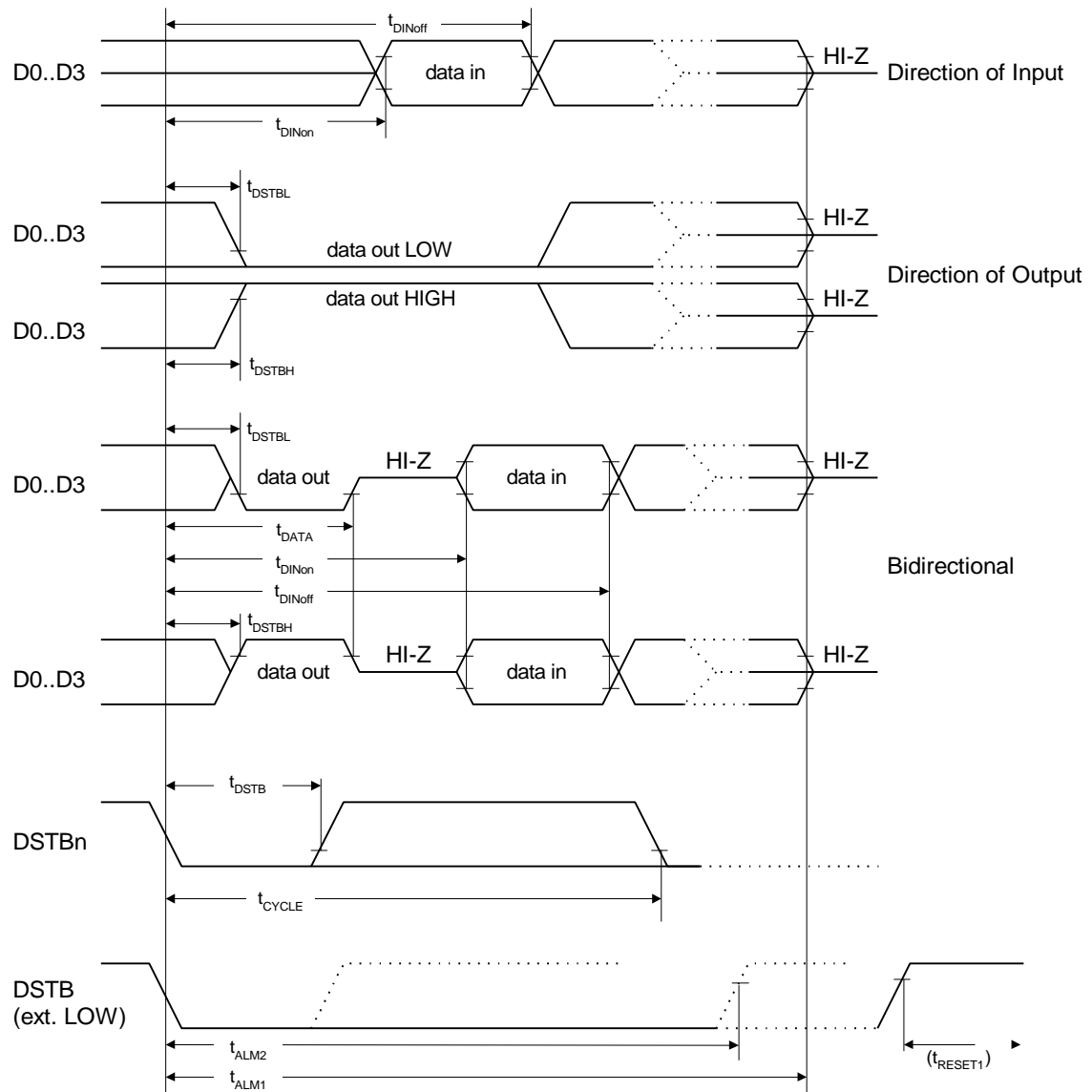

e) Interface to the ext. E²PROM (U5R, SCL, SDA) / functional, electrical and timing characteristics

Symbol	Parameter	min	max	Unit	Note
VU5R	Output Voltage to E ² PROM	4.5	5.5	V	IU5R ≤ 3 mA
CU5R	Load Capacity to U5R	10	220	nF	Ceramics capacitor
IU5R	Output Current to U5R		3	mA	
VOL	Output Voltage "Low"	0	0.2 * VU5R	V	IOL = 10 μA
VOH	Output Voltage "High"	0.8 * VU5R	VU5R	V	-IOH = 10 μA
VIL	Input Voltage "Low" (only SDA)	-0.3	0.3 * VU5R	V	-IIL = 1.5...0.2mA
VIH	Input Voltage "High" (only SDA)	0.7 * VU5R	VU5R + 0.3	V	IIH = -1...1 μA
t _{DATAinSU}	Set-up Time for Data Input	0.25		μs	
t _{DATAinHO}	Hold Time for Data Input	0		μs	
t _{AA}	Time from SCK Low to SDA Data Out and ACK Out		3.5	μs	
t _{DATAoutHO}	Hold Time for Data Output	0.3		μs	
t _{STARTSU}	Set-up Time for Start Condition	4.7		μs	
t _{STARTHO}	Hold Time for Start Condition	4		μs	
t _{STOPSU}	Set-up Time for Stop Condition	4.7		μs	
t _{BUF}	Time which has to be Free for Bus: Before Next Transmission	4.7		μs	
t _R	Rise Time		1000	ns	
t _F	Fall Time		300	ns	
t _{LOW}	Impulse LOW Time	4700		ns	
t _{HIGH}	Impuls HIGH Time	4000		ns	
t _{SCL}	Clock Frequency for E ² PROM		100	kHz	f _c = 5.333 MHz

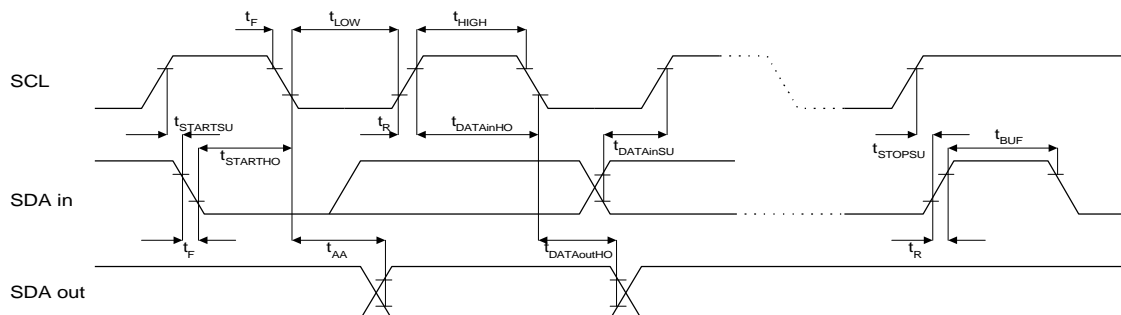

The U5R supply pin provides a typically 5V supply voltage to the external E²PROM, and has a biasing capability only for this purpose.

Programming of the E²PROM is possible with the E²PROM soldered-in into the AS-Interface Slave unit's pc-board by accessing the SCL / SDA serial bus with an external programming hardware.

For successful programming the programmer hardware must have sink/source capability of at least 5 mA, and the AS-Interface Slave IC's supply voltage LTGP has to be in the range of 26.65 V ...33.35 V.

The only E²PROM address locations which can be programmed through the AS-Interface Slave IC (hence over the AS-Interface Bus and by the AS-Interface Master), are locations 0 and 1, which both have been reserved for the AS-Interface Slave unit's address.

The E²PROM has to be programmed in the following way:

E ² PROM Address	D7	D6	D5	D4	D3	D2	D1	D0	Initialization Data
0	0	0	0	AS-Interface address					0
1	0	0	0	AS-Interface address					0
2	ID Code			IO Configuration			Custom Specific Data		
3	ID Code			IO Configuration			Custom Specific Data		

Recommended E²PROM types:

Supplier	Type	Organization
Philips	PCA8581P	128 x 8
ST	ST24C01	128 x 8
Catalyst	CAT24LC02(Z)IP	256 x 8
Xicor	X24LC02PI	256 x 8
Catalyst	CAT24LC04(Z)IP	512 x 8
Xicor	X24(L)C04PI	512 x 8

f) Sensor / actuator supply pin UOUT / Functional and electrical characteristics

Symbol	Parameter	min	max	Unit	Note
VUOUT	Output Voltage at UOUT	VLTGP – VDROPMIN	VLTGP – VDROPMIN	V	IUOUT = 35 mA
VUOUTp	Overswing of the Output Voltage		1.5	V	CUOUT = 10 µF: Switching 0-35 mA - 0
tUOUTP	Overswing Impulse Width		2.	ms	
VDROP	Voltage Drop from LTGP to UOUT	5.5	6.7	V	
IUOUT	Output Current UOUT	0	35	mA	11.0 V < VUOUT < 27.6 V
CUOUT	Load Capacity UOUT	10	470	µF	

The interface is intended for the supply voltage to actuators, sensors as well as external circuits with a power supply of <35mA without overloading the AS-Interface line in the range of the signal frequency. The AS-Interface slave IC has an internal circuit protector which limits the current during the charging of the load capacitor and which effects a power down at thermal overload, e.g. at too high output currents.

In the case of a current break down on the AS-Interface line of less than 1ms, the internally stored information is retained. The supply voltage of the IC during this time is extracted from the capacitor Pin UOUT which is disconnected from the AS-Interface line.

Reset Behaviour

The AS-Interface Slave IC can be in reset condition or reset by the following events:

- at power-up of VLTGP: as long as VUOUT has not yet reached the threshold voltage $9\text{ V} \leq \text{VCOMOFF} \leq 11\text{ V}$;
- at power-down of VLTGP: as soon as U5R drops below the threshold voltage $3.5\text{ V} \leq \text{VPOR} \leq 4\text{ V}$;
- by a 'L' input level to DSTBn for more than 44 μs ;
- resulting from a "Reset AS-Interface Slave"- command by the AS-Interface Master over the AS-Interface BUS.

The different levels of VCOMOFF and VPOR as per a) and b) and the fact that the U5R supply voltage results from a down-regulation of the VUOUT supply assure a desirable hysteresis in the order of several volts between the VUOUT power-on-reset and power-down-reset threshold. Whereas at power-up the AS-Interface Slave IC is released from reset by VUOUT reaching a level of between 9 V and 11 V, at power-down VUOUT has to come down to a level in the order of 5 V for U5R to drop into the reset-triggering window between 3.5 V and 4 V.

Some different power-down events are illustrated below:

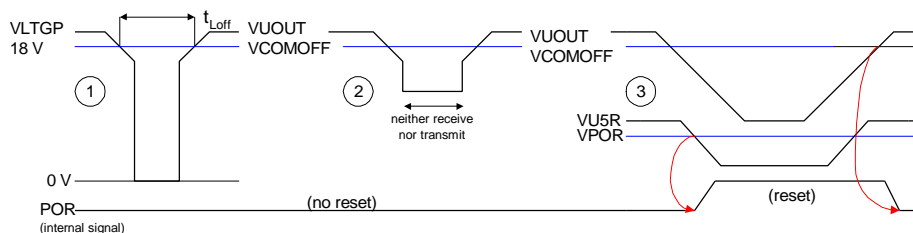

Notes:

- as to (1): No reset will be triggered, if VLTGP is lower than 18 V for less than 1 ms
- as to (2): If $\text{VUOUT} < \text{VCOMOFF}$ but still $\text{U5R} > \text{VPOR}$, communication over the Data Port is inhibited, but no reset triggered
- as to (3): If $\text{U5R} < \text{VPOR}$ (resulting from $\text{VUOUT} \ll \text{VCOMOFF}$), a reset is triggered. Reset is overcome as soon as $\text{VUOUT} > \text{VCOMOFF}$ (implying $\text{U5R} > \text{VPOR}$)

In reset condition internal registers are cleared and data port D0...D3 is switched into high-impedant condition. After release from reset the AS-Interface Slave automatically performs a first read cycle to clear the E²PROM from any previously interrupted communication state and a second one to load the AS-Interface address, IO Configuration and ID Code into its internal registers.

Symbol	Parameter	min	max	Unit	Note
t reset	Reset Time after the Master Command "Reset AS-Interface Slave" or DSTBn = ext. L/H-Edge		2	ms	
t reset2	Reset Time after Power On		30	ms	
t reset3	Reset Time after Power On with great Load Capacity		1000	ms	CUOUT = 470 μF
t Loff	Voltage Breakdown Time		1	ms	CUOUT > 10 μF
VCOMMoff	Voltage for "Communication OFF"	9	11	V	
VPOR	Voltage for Internal Reset	3.5	4	V	

Application Example 1:

Sensor/actuator circuit supplied by the AS-Interface Slave IC (UOUT) for supply current needs ≤ 35 mA.

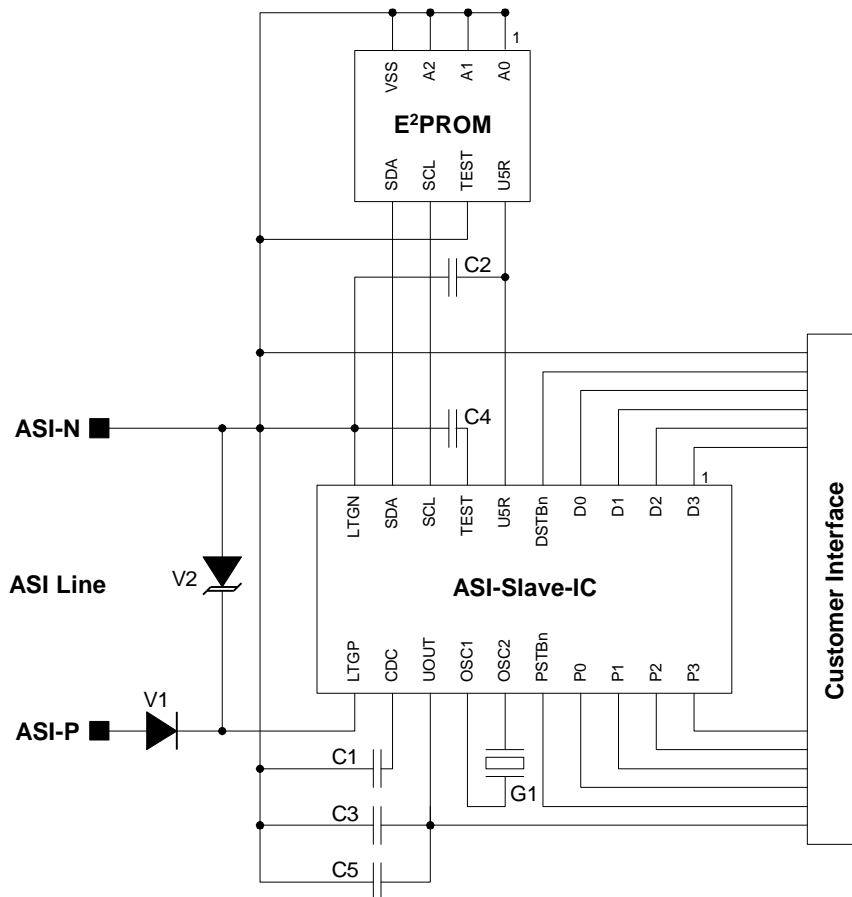

- C1 = 22...470 nF / max. AS-Interface BUS DC voltage
- C2 = 10...220 nF / max VU5R = 5.5 V
- C3 = 10...470 μ F / max. $(V_{UOUT} + V_{UOUTp}) = 29.1$ V
- C4 = 22...100 nF / max. $(V_{UOUT} + V_{UOUTp} + 1.4$ V) = 30.5 V
- C5 = 10...100 nF (close to the IC) / max. $(V_{UOUT} + V_{UOUTp}) = 29.1$ V
- V1 = 1N4002 or equivalent
- V2 = TGL 41-39A or equivalent
- G1 = AS-Interface Crystal 5.333 MHz

For V2 a limiter diode with a small capacitance value should be selected, to ensure that the AS-Interface Bus can be operated with the maximum number of Slave units connected.

In a more general sense care should be taken that the pc board tracks and the external components between the AS-Interface Bus and LTGP / LTGN contribute to the AS-Interface Slave unit's input impedance inductively and highly resistively, rather than capacitively.

Application Example 2:

Sensor / actuator circuit supplied from the AS-Interface Bus for supply current needs > 35 mA. It is recommended to protect the AS-Interface Bus by a fuse in this set-up, if there is a high risk of excessive current extraction due to component failure (e.g.: MC1747 or other components in the sensor / actuator circuitry).

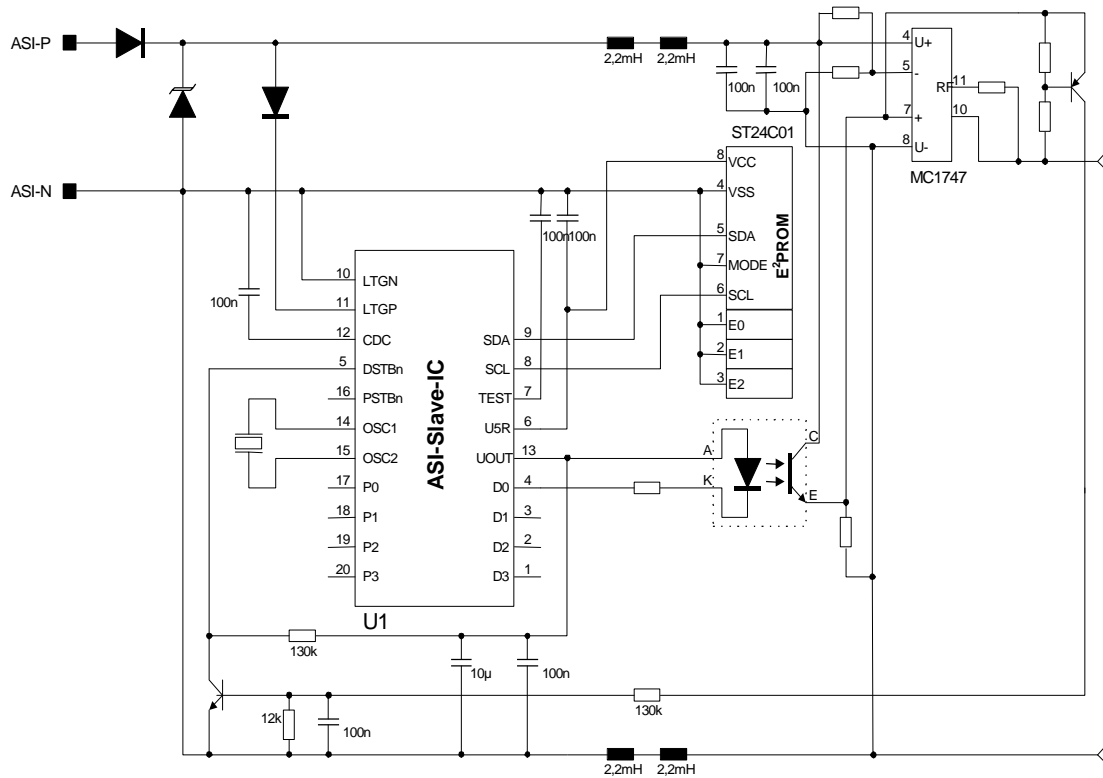

AS-Interface Quartz 5.333 MHz

AS2701A works fine with the following crystal types:

- Citizen CM 309
- Philips SQ 4849

AS-Interface quartz crystals are available from:

Endrich GmbH
Contact: Axel Gensler
Hauptstr. 56
D-72202 Nagold
Tel.: +49-7452-6007-31
Fax: +49-7452-6007-70
Email: a.gensler@endrich.com

Geyer electronic
Contact: Jürgen Blank
Camerloherstr. 71
D-80689 München
Tel.: +49-89-546868-13
Fax: +49-89-546868-90

Kinseki Europe GmbH
Contact: Dirk Holstein
Schirmer Str. 76
D-40211 Düsseldorf
Tel.: +49-211-36815-33
Fax: +49-211-36815-10
Email: dholstein@kinseki.de

Rutronik Elektronische Bauelemente GmbH
Contact: Jürgen Tischhauser
Industriestraße 2
D-75228 Ispringen / Pforzheim
Tel.: +49-7231-801543
Fax: +49-7231-801633
Email: juergen_tischhauser@rutronik.com

Application Support

- a) For general information and documentation on the AS-Interface concept you may contact one of the following AS-Interface Associations:

AS-International Association
Contact: Rolf Becker
Zum Taubengarten 52
D-63571 Gelnhausen
Tel.: +49-6051-473212
Fax: +49-6051-473282
Email: as-interface@t-online.de

AS-Interface Switzerland
Contact: Rainer Schnaidt
Bittertenstraße 15
CH-4702 Oensingen
Tel.: +41-62-388-2567
Fax: +41-62-388-2525
Email: rainer.schnaidt@fho.ch

AS-Interface France
Contact: Gilles Mazet
5 rue Nadar
F-92566 Rueil Malmaison cedex
Tel.: +33-1-41-298294
Fax: +33-1-41-298482
Email: gilles_mazet@mail.schneider.fr

AS-Interface Italy
Contact: Maurizio Ghizzoni
Via G.B. Barinetti, 1
I-20145 Milano
Tel.: +39-02-66761
Fax: +39-02-6676-3491
Email: maurizio.ghizzoni@siemens.it

AS-Interface The Netherlands
Contact: Andre Braakman
Boerhaavelaan 40
NL-2700 AD Zoetermeer
Tel.: +31-79-353-1269
Fax: +31-79-353-1365
Email: ABA@FME.NL

AS-Interface Great Britain
Contact: Geoff Hodgkinson
1 West Street
GB-PO 14 4DH Titchfield, Hampshire
Tel.: +44-1329-511882
Fax: +44-1329-512063
Email: asi_uk@gghcomms.demon.co.uk

AS-Interface USA
Contact: Michael Bryant
16101 N. 82nd Street, Suite 3B
USA-85260 Scottsdale, Arizona
Tel.: +1-480-368-9091
Fax: +1-480-483-7202
Email: mbryant@goodnet.com

AS-Interface Belgium
Contact: Maurice de Smedt
Avenue Paul Hymanslaan 47
B-1200 Bruxelles-Brussel
Tel.: +32-2-771-3912
Fax: +32-2-771-1264
Email: m.desmedt@udias.be

AS-Interface Sweden
Contact: Lars Mattsson
Karl Nordströms väg 31
SE-43253 Varberg
Tel.: +46-3406-29270
Fax: +46-3406-77190
Email: lars-mattsson@marknadspartnermol.se

b) A demoboard, equipped with AS2701A and supporting discrete components, is available from:

Bihl & Wiedemann GmbH
Mr. Bihl
Käfertaler Straße 164
D-68167 Mannheim
Tel.: +49-621-339-2723
Fax: +49-621-339-2239

Leuze electronic GmbH
Mr. Keller
In der Braike 1
D-73277 Owen/Teck
Tel.: +49-7021-573-248
Fax: +49-8021-573-200

c) Technical hotline assistance is provided by:

Bihl & Wiedemann GmbH (see above)

Bibliography

ASI: The Actuator-Sensor-Interface for Automation
Edts.: Werner Kriesel, Otto W. Madelung
Carl Hanser Verlag, Munich and Vienna, 1995
ISBN: 3-446-18265-9

Ordering Information

AS2701A	Package: SOIC 20	Delivery: Tubes
AS2701AT	Package: SOIC 20	Delivery: Tape & Reel