

802.11b PCI/CARDBUS/PCMCIA Bus WLAN MAC Controller

Document No.: AX81190-07 / V0.7 / MAR. 15 '03

Features

- Single chip multiple bus WLAN MAC Controller
- IEEE 802.11b wireless LAN (WLAN) Compatible
- Compliant with 802.11b protocol such as DCF, PCF, WEP, Power management, etc.
- Embedded two 8K * 16 bit SRAMs for Tx and Rx Packet Buffers
- Compliant with PCI Bus Standard Ver 2.1(slave mode)/PCMCIA Bus standard.
- Support PCI 16-bit acssee for Registers and 32-bit acssee for Data
- Support both 1/2/5.5/11 Mbps data rate
- Support both full-duplex (Test) or half-duplex operation
- Provides an industrial standard interface to interface with baseband processor and IF/RF chips.
- Support 256 bytes EEPROM (used for saving Configuration Information and address ID)
- Support automatic loading of MAC ID and Adapter Configuration from EEPROM on power-on initialization
- 128-pin TQFP low profile package
- 33/44MHz, 2.5Vcore/3.3V IO operation with 5V tolerance

*IEEE is a registered trademark of the Institute of Electrical and Electronic Engineers, Inc.

*All other trademarks and registered trademark are the property of their respective holder.

Product description

The AX81190 is a high performance multiple bus WLAN MAC Controller. The AX81190 contains a 16 bit PCMCIA interfaces (32-bit PCI/CARDBUS) to host CPU and compliant with PCMCIA Bus Standard Ver 2.2. The AX81190 implements 1Mbps, 2Mbps, 5.5Mbps and 11Mbps WLAN function based on DSSS (Direct Sequence Spread Spectrum) of IEEE802.11 /IEEE802.11b WLAN standard. The AX81190 supports an industrial standard(such as Intersil /RFMD/RaLink) interface for baseband processor and IF/RF chips to simplify the design.

SYSTEM BLOCK DIAGRAM

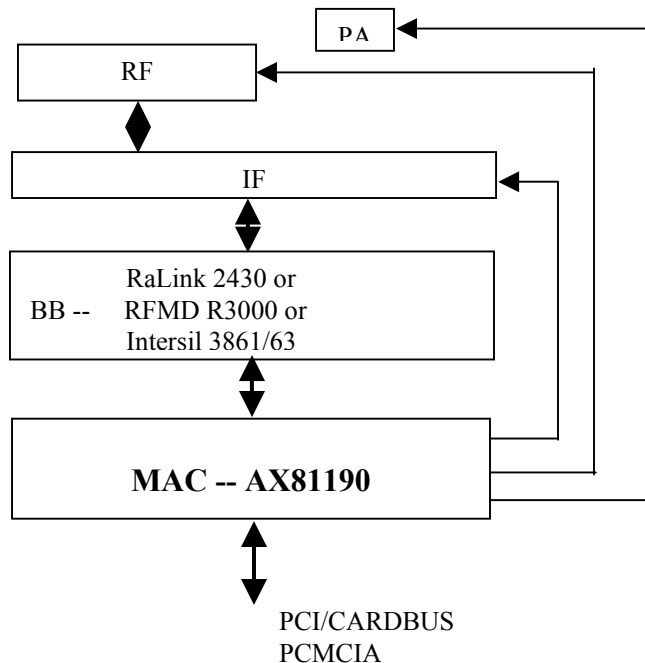

Always contact ASIX for possible updates before starting a design. This data sheet contains new products information. ASIX ELECTRONICS reserves the rights to modify product specification without notice. No liability is assumed as a result of the use of this product. No rights under any patent accompany the sale of the product.



CONTENTS

1.0 INTRODUCTION	6
1.1 GENERAL DESCRIPTION	6
1.2 AX81190 BLOCK DIAGRAM	6
1.3 AX81190 PIN CONNECTION DIAGRAM	7
1.3.1 AX88119 Pin Connection Diagram for PCMCIA Bus Mode	7
1.3.2 AX81190 Pin Connection Diagram for PCI/CardBus Mode	8
2.0 SIGNAL DESCRIPTION	9
2.1 PCMCIA BUS INTERFACE SIGNALS GROUP	9
2.2 PCI/CARDBUS BUS INTERFACE SIGNALS GROUP	10
2.3 EEPROM SIGNALS GROUP	11
2.4 SERIAL PORT INTERFACE SIGNALS GROUP	11
2.5 BASEBAND PROCESSER CONTROLLER INTERFACE SIGNALS GROUP	11
2.6 POWER CONTROL INTERFACE SIGNALS GROUP	12
2.7 SYNTHESIZER CONTROL SIGNAL INTERFACE PINS GROUP	12
2.8 MISCELLANEOUS PINS GROUP	12
3.0 REGISTERS OPERATION	14
3.1 PCI CONFIGURATION REGISTER	14
3.1.1 Device vendor register -- offset 00h	14
3.1.2 Command register – offset 04h	14
3.1.3 Status register – offset 06h	14
3.1.4 Revision ID register – offset 08h	14
3.1.5 Class code register – offset 09h	15
3.1.6 Base IO address register – offset 10h	15
3.1.7 Base Memory address register – offset 14h	15
3.1.8 CIS pointer – offset 28h	15
3.1.9 Subsystem ID – 2Ch	15
3.1.10 Interrupt register – 3Ch	15
3.2 PCMCIA CONFIGURATION REGISTER	16
3.2.1 COR register – 0800h	16
3.2.2 CCR register – 0802h	16
3.2.3 IO base (LSB) – 0804h	16
3.2.4 IO base (MSB) – 0806h	16
3.3 IO PORT	17
3.3.1 CSR index port base	17



3.3.2	CSR data port	base + 2	17
3.3.3	Tx Data access control port	base + 4	17
3.3.4	Tx data buffer port	base + 6	17
3.3.5	Rx Data access control port	base + 8	17
3.3.6	Rx data buffer port	base + ah	17
3.3.7	Soft reset port	base + eh	17
3.3.8	Interrupt status port	base + 10h	17
3.3.9	Interrupt mask port	base + 12h	18
3.3.10	Rx page status port	base + 14h	18
3.3.11	Tx page status port1	base + 16h	18
3.3.12	Tx page status port2	base + 18h	19
3.3.13	BBP_index port	base + 1ah	19
3.3.14	BBP_data out port	base + 1ch	19
3.3.15	BBP_data in port	base + 1eh	19
3.3.16	Synthesizer control port	base + 20h	19
3.3.17	Synthesizer data port0	base + 22h	19
3.3.18	Synthesizer data port1	base + 24h	19
3.3.19	EE_data port	base + 26h	20
3.3.20	EE_cmd/addr port	base + 28h	20
3.3.21	EE_status_type port	base + 2ah	20
3.4	MAC CONFIGURATION STATUS REGISTERS		21
3.4.1	CSR1 – MAC Physical address0 (PADR[15:0])		21
3.4.2	CSR2 – MAC Physical address1 (PADR[31:16])		21
3.4.3	CSR3 – MAC Physical address2 (PADR[47:32])		21
3.4.4	CSR4 – BSSID Matching Register0, BSSID[15:0]		21
3.4.5	CSR5 – BSSID Matching Register1, BSSID[31:16]		21
3.4.6	CSR6 – BSSID Matching Register2, BSSID[47:32]		21
3.4.7	CSR7 ~ CSR9 are reserved.		21
3.4.10	CSR10 – Multicast filter pattern1		21
3.4.11	CSR11 – Multicast filter pattern2		21
3.4.12	CSR12 – Multicast filter pattern3		21
3.4.13	CSR13 – Multicast filter pattern4		21
3.4.12	CSR14 ~ CSR15 are reserved.		22
3.4.16	CSR16 – clock pattern		22
3.4.17	CSR17 – Wait md_rdy duration		22
3.4.18	CSR18 – Short Interframe space timing register ,SIFS		22
3.4.19	CSR19 – Distributed Interframe space timing register, DIFS/PIFS		22
3.4.20	CSR20 ~ CSR 21 – Reserved.		22
3.4.22	CSR22 – SlotTime Register (SLOT)		22
3.4.23	CSR23 – Backoff timing		22
3.4.24	CSR24 – RF3000 modulation duration (Testing)		22
3.4.25	CSR25 – Power Testing and misc		22



3.4.26	CSR26 – TXVGC adjust register (support RF3000 only)	23
3.4.27	CSR27 – Tx Beacon/probe response enable register	23
3.4.28	CSR28 – TBTT Compensation Register	23
3.4.29	CSR29 – Rx filtering Register	23
3.4.30	CSR30 – TX Power Ramp-up Control Register1	24
3.4.31	CSR31 – TX Power Ramp-up Control Register2	24
3.4.32	CSR32 – TX Power Ramp Control Register3	24
3.4.33	CSR33 – TX Power Ramp Control Register4	24
3.4.34	CSR34 – TX Power Ramp Control Register5	24
3.4.35	CSR35 – BeaconPeriod (BP)	24
3.4.36	CSR36 – Tx Retry counter	24
3.4.37	CSR37 – MAC feature register	24
3.4.38	CSR38 is Reserved	25
3.4.39	CSR39 – Transmit page control register	25
3.4.40	CSR40 – TX Rate control register	25
3.4.41	CSR41 – response time-out register	26
3.4.42	CSR42 – RSSI-SQ location register	26
3.4.43	CSR43 – TSF compensate register	26
3.4.44	CSR44 – Calibration adjust register	26
3.4.45	CSR45 – BBP PLCP Service/Signal field location register (for Intersil 3861/3863)	26
3.4.46	CSR46 – BBP PLCP Length field location register (for Intersil 3861/3863)	26
3.4.47	CSR47 is Reserved	27
3.4.48	CSR48 – Software reset duration	27
3.4.49	CSR49 – CFP duration register	27
3.4.50	CSR50 – ATIM duration register	27
3.4.51	CSR51 – 802.11 protocol status	27
3.4.52	CSR52 – MAC mode status	27
3.4.53	CSR53 – BBP mode	27
3.4.54	CSR54 – SPI chip address	28
3.4.55	CSR55 ~ CSR59 reserved	28
3.4.60	CSR60 CRC32 counter	28
3.4.61	CSR61 is reserved	28
3.4.62	CSR62 – NAV timer	28
3.4.63	CSR63 – TSF timer register0 (TSFR[15:0])	28
3.4.64	CSR64 – TSF timer register1 (TSFR[31:16])	28
3.4.65	CSR65 – TSF timer register2 (TSFR[47:32])	28
3.4.66	CSR66 – TSF timer register3 (TSFR[63:48])	28
3.4.67	CSR67 ~ CSR69 Reserved	28
3.4.70	CSR70 – Not my unicast frame counter	28
3.4.71	CSR71 – broadcast and multicast counter	29



3.4.72	CSR72 – RSSI-SQ value.....	29
3.4.73	CSR73 – Outbuf/Inbuf current page pointer	29
3.4.74	CSR74: TX Power Ramp-down Control Register1	29
3.4.75	CSR75: TX Power Ramp-down Control Register2	29
3.4.76	CSR76: TX Power Ramp-down Control Register3	29
3.4.77	CSR77: TX Power Ramp-down Control Register4	29
3.4.78	CSR78: RX_PE de-asserted duration.....	29
3.4.79	CSR79: Min size of RX packet	30
3.4.80	CSR80: GPIO status control.....	30
3.4.81	CSR81: GPIO data port.....	30
3.4.82	CSR82: wep control	30
3.4.83	WEP key matrix (csr83 ~ csr110, 16 bit registers).....	30
4.0	PCMCIA DEVICE ACCESS FUNCTIONS.....	31
4.1	ATTRIBUTE MEMORY ACCESS FUNCTIONS.....	31
4.2	I/O ACCESS FUNCTIONS.....	31
5.0	ELECTRICAL SPECIFICATION AND TIMINGS	32
5.1	ABSOLUTE MAXIMUM RATINGS.....	32
5.2	GENERAL OPERATION CONDITIONS.....	32
5.3	DC CHARACTERISTICS.....	32
5.4	A.C. TIMING CHARACTERISTICS.....	33
5.4.1	CLOCK.....	33
5.4.2	PCMCIA Reset Timing.....	33
5.4.3	PCMCIA Attribute Memory Read Timing.....	34
5.4.4	PCMCIA Attribute Memory Write Timing.....	35
5.4.5	PCMCIA I/O Read Timing.....	36
5.4.6	PCMCIA I/O Write Timing.....	37
5.4.7	Synthesizer Timings.....	38
5.4.8	Serial Port Timings	39
5.4.9	TX Path Waveforms.....	40
5.4.10	RX Path Waveforms	41
6.0	PACKAGE INFORMATION.....	42
APPENDIX A: APPLICATION NOTE 1.....	43	
A.1	EXTERNAL EEPROM FORMAT	43



1.0 Introduction

1.1 General Description

The AX81190 Wireless LAN Controller is a high performance PCMCIA/PCI bus WLAN Controller. The AX81190 contains a 16 bit PCMCIA (32 bit PCI) interfaces to host CPU. The AX81190 implement 1Mbps, 2Mbps, 5.5Mbps and 11Mbps WLAN function based on IEEE802.11 /IEEE802.11b WLAN standard. The AX81190 supports industrial standard MAC to Baseband controller interface to simplify the design. The AX81190 is built in two 8K*16 bit SRAM for Tx and Rx packet buffer to reduce system cost and size. AX81190 is also implemented WEP (hardwared) function, supports 64/128 bit key to reduce computing load of CPU.

AX81190 use 128-pin TQFP low profile package, 33/44MHz operation frequency, 2.5V core/3.3V CMOS process with 5V I/O tolerance.

1.2 AX81190 Block Diagram

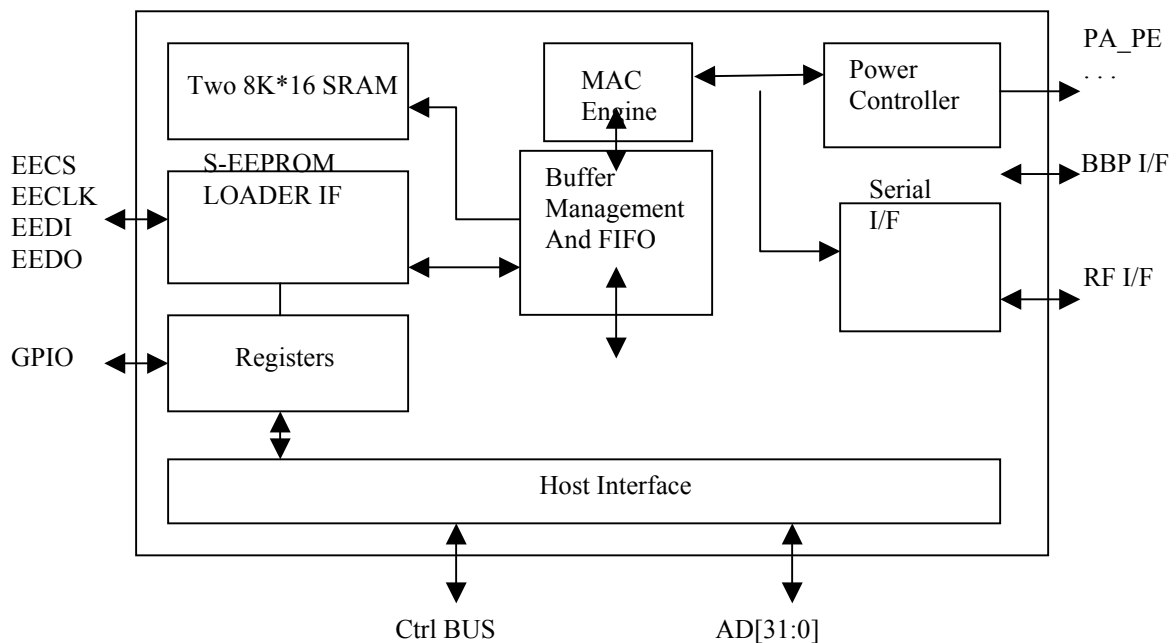



1.3 AX81190 Pin Connection Diagram

The AX81190 is housed in the 128-pin plastic quad flat pack Fig - 1 AX81190 Pin Connection Diagram shows the AX81190 pin assignment.

1.3.1 AX81190 Pin Connection Diagram for PCMCIA Bus Mode

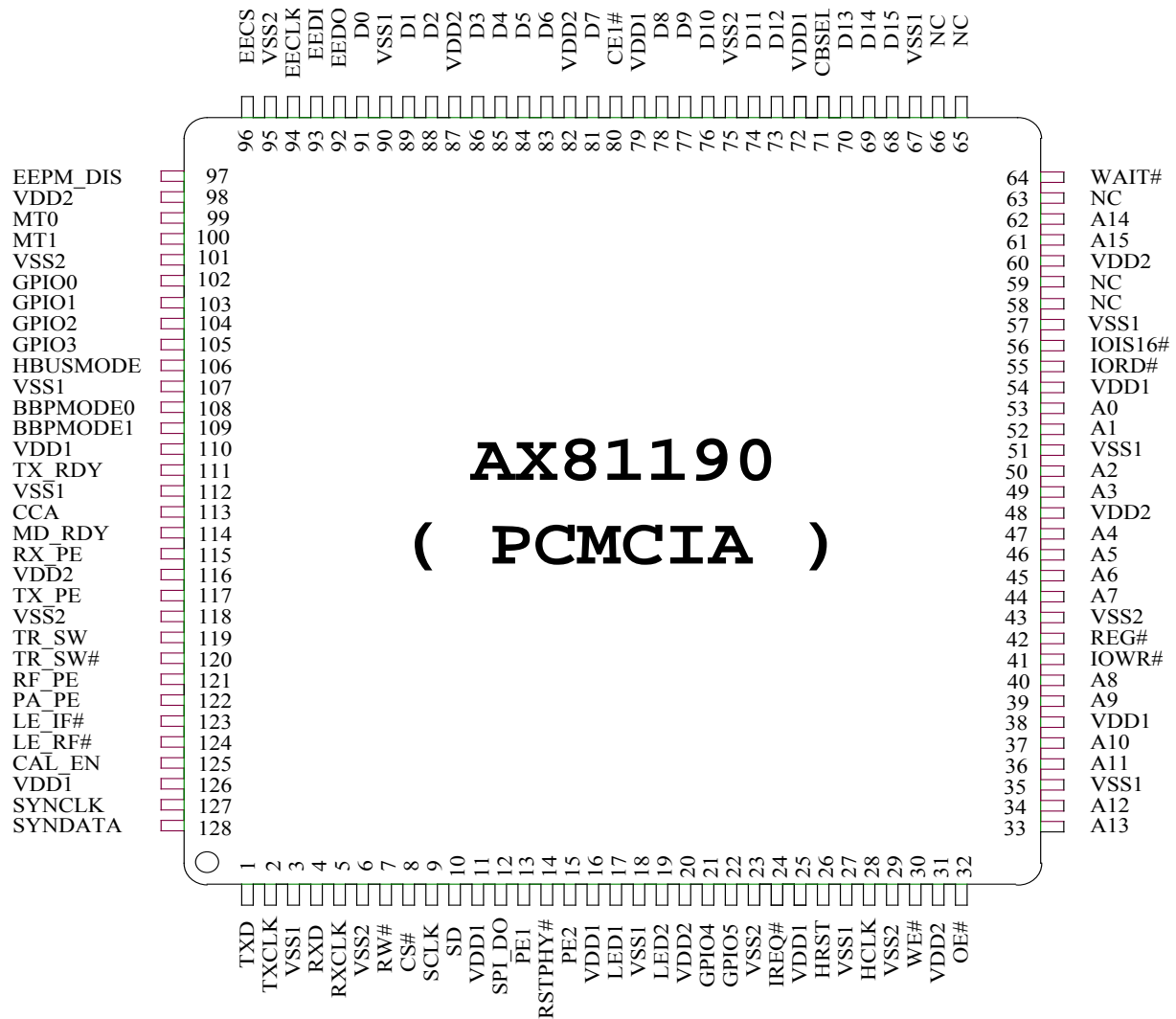

Fig - 1 AX81190 Pin Connection Diagram for PCMCIA Bus Mode



1.3.2 AX81190 Pin Connection Diagram for PCI/CardBus Mode

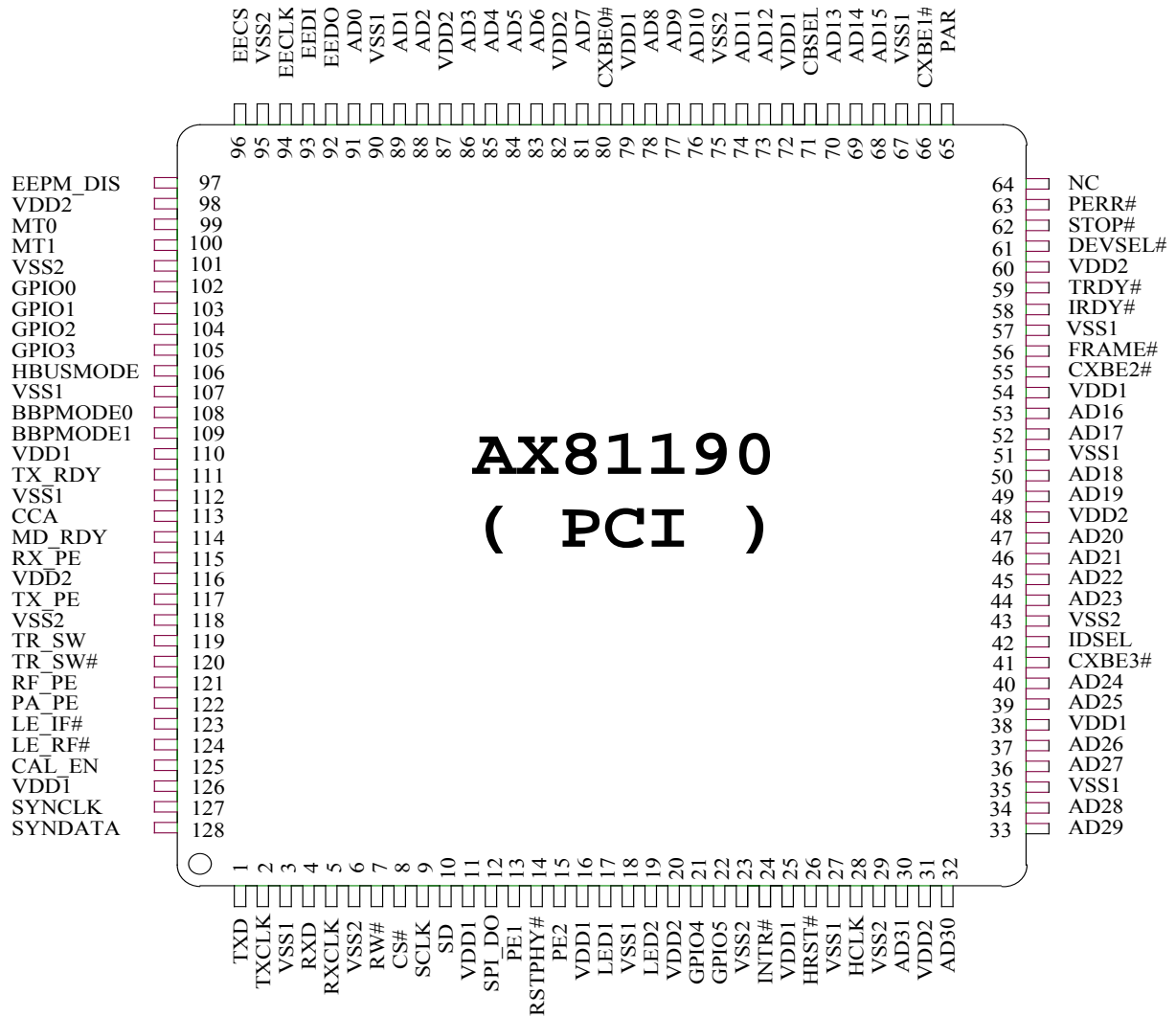

Fig - 2 AX81190 Pin Connection Diagram for PCI/CARDBUS



2.0 Signal Description

The following terms describe the AX81190 pin-out:
All pin names with the “#” suffix are asserted low.
The following abbreviations are used in following Tables.

I	Input	PU	Internal Pull Up
O	Output	PD	Internal Pull Down
I/O	Input/Output	P	Power Pin
OD	Open Drain		

2.1 PCMCIA Bus Interface Signals Group

SIGNAL	TYPE	PIN NO.	DESCRIPTION
HCLK	I	28	Reference clock. 33Mhz or 44Mhz.
HRST	I	26	Reset signal. Active high for PCMCIA.
A[15:0]	I	61,62,33,34,36,37,39,40,44,45,46,47,49,50,52,53	System Address : Signals A[15:0] are address bus input lines which enable direct address of up to 64K memory and I/O spaces on card.
D[15:0]	I/O	68,69,70,73,74,76,77,78,81,83,84,85,86,88,89,91	System Data Bus : Signals D[15:0] constitute the bi-directional data bus.
IREQ#	O	24	Interrupt Request : IREQ# is asserted to indicate the host system that the PC Card device requires host software service.
WAIT#	O	64	Wait : This signal is set low to insert wait states during Remote DMA transfer.
REG#	I	42	Attribute Memory and I/O Space Select : When the REG# signal is asserted, access is limited to Attribute Memory and to the I/O space.
IORD#	I	55	I/O Read : The host asserts IORD# to read data from AX81190 I/O space.
IOWR#	I	41	I/O Write : The host asserts IOWR# to write data into AX81190 I/O space.
OE#	I	32	Output Enable : The OE# line is used to gate Memory Read data from memory on PC Card
WE#	I	30	Write Enable : The WE# signal is used for strobing Memory Write data into the memory on PC Card.
IOIS16#	O	56	I/O is 16 Bit Port : The IOIS16# is asserted when the address at the socket corresponds to an I/O address to which the card responds, and the I/O port addressed is capable of 16-bit access.
CE1#	I	80	Card Enable : The CE1# enables even numbered address bytes.

PCMCIA bus interface signals group



2.2 PCI/CARDBUS Bus Interface Signals Group

SIGNAL	TYPE	PIN NO.	DESCRIPTION
HCLK	I	28	The clock provides the timing for the AX81190 related PCI bus transactions. All the bus signals are sampled on the rising edge of HCLK. The max frequency is 33MHz.
HRST#	I	26	Resets the AX81190 to its initial state. This signal must be asserted for at least 10 active PCI clock cycles. When in the reset state, all PCI output pins are put into tri-state and all PCI o/d signals are floated.
FRAME#	I/O	56	The FRAME# Signal is driven by the master to indicate the beginning and duration of an access. FRAME# Asserts to indicate the beginning of a bus transaction. While FRAME# is asserted, data transfers continue. When FRAME# deasserts the next data phase is the final data phase transaction.
IRDY#	I/O	58	Initiator ready Indicates the bus master ability to complete the current data phase of the transaction. A data phase is completed on any rising edge of the clock When both IRDY# and target ready TRDY# are asserted. Wait cycles are inserted until both IRDY# and TRDY# are asserted together.
TRDY#	I/O	59	Target ready indicates the target ability to complete the current data phase of the transaction. A data phase is completed on any clock when both TRDY# and IRDY# are asserted. Wait cycles are inserted until both IRDY# and TRDY# are asserted together.
DEVSEL#	I/O	61	Device select Is asserted by the AX81190 of the current bus access hit to AX81190
STOP#	I/O	62	Stop indicator indicates that the current target is requesting the bus master to stop the current transaction.
PAR	I/O	65	Parity is an even parity bit for the AD[31:0] AD and CXBE[3:0]#. During address and data phases, parity is calculated on all the AD[31:0] AND CXBE[3:0]# lines whether or not any of these lines carry meaningful information.
IDSEL	I	42	Initialization device select asserts To indicate that the host is issuing a configuration cycle to the AX81190. For cardbus application, this pin always is pulled high with VDD1.
AD[31:0]	I/O	30,32,33,34,36,37,39,40,44,45,46,47,49,50,52,53,68,69,70,73,74,76,77,78,81,83,84,85,86,88,89,91	Address and data bits are multiplexed on the same pins. During the address phase, the AD[31:0] contain a physical address (32 bits). During, data phases, AD[31:0] contain 32 bits of data.
CXBE[3:0]#	I/O	41,55,66,80	BUS COMMAND and BYTE ENABLE Are multiplexed on the same PCI pins. During the address phase of the transaction, CXBE[3:0]# Provide the BUS COMMAND. During the data phase, CXBE[3:0]# Provide the BYTE ENABLE. The BYTE ENABLE determines which byte lines carry valid data., CXBE0# Applies to byte 0, and CXBE3# Applies to byte 3.
PERR#	I/O	63	Parity error asserts when a data parity error is detected. when a parity error is detected, the AX81190 asserts PERR#. This pin must be pulled up with VDD2 by an external resistor.



AX81190 PCI/CARDBUS/PCMCIA Bus WLAN MAC

INTR#	O/D	24	Interrupt request asserts When one of the appropriate bits of Interrupt Status Register sets and causes an interrupt, provided that the corresponding mask bit in Interrupt Mask Register is not asserted. Interrupt request deasserts by writing an “1” into the appropriate Interrupt Status Register bit. This pin must be pulled up with VDD2 by an external resistor.
-------	-----	----	---

PCI/CARDBUS bus interface signals group

2.3 EEPROM Signals Group

SIGNAL	TYPE	PIN NO.	DESCRIPTION
EECS	O	96	EEPROM Chip Select : EEPROM chip select signal.
EECLK	O	94	EEPROM Clock : Signal connected to EEPROM clock pin.
EEDI	O	93	EEPROM Data In : Signal connected to EEPROM data input pin.
EEDO	I/PD	92	EEPROM Data Out : Signal connected to EEPROM data output pin.

EEPROM bus interface signals group

2.4 Serial Port Interface Signals Group

SIGNAL	TYPE	PIN NO.	DESCRIPTION
SCLK	O	9	SCLK is the clock for SD serial bus. The data on SD is latched in rising edge.
SD	I/O/PD	10	SD is serial bi-directional data bus, which is used to transfer address and data to/from BBP internal register for Intersil type BBP. This signal is input only for RFMD type BBP.
SPI_DO	O	12	SPI_DO is serial data output only bus, which is used to transfer address and data to RFMD type BBP.
RW#	O	7	To control the direction when MAC reads or writes data on SD bus. A high level indicates a read cycle and low level indicates a write cycle.
CS#	O	8	MAC selects BBP to be as target.

Serial port interface signals group

2.5 Baseband Processor Controller interface signals group

SIGNAL	TYPE	PIN NO.	DESCRIPTION
TXD	O	1	MAC transmits data to BBP. The data is valid in rising edge of TXCLK.
TXCLK	I	2	The clock from BBP is to be valid TXD.
TX_RDY	I	111	BBP indicates the valid data phase.
TX_PE	O	117	To control the transmitted phase.
CCA	I	113	MAC will monitor this signal to determine whether it can transmit data or not.
RXD	I	4	RXD is an input from BBP. The data is sent serially with LSB first and the data is frame aligned with RX_RDY.



AX81190 PCI/CARDBUS/PCMCIA Bus WLAN MAC

RXCLK	I	5	This is the bit clock input from BBP. This clock is used to transfer header information and payload data through the RXD serial bus. RXCLK becomes active after SFD has been detected. Data (RXD) should be samples on rising edge.
MD_RDY	I	114	BBP indicates header data and data packet are ready to be transferred.
RX_PE	O	115	MAC enables BBP to qualify receive stage.

Baseband Processor interface signals group

2.6 Power Control Interface Signals Group

SIGNAL	TYPE	PIN NO.	DESCRIPTION
CAL_EN	O	125	Calibration mode enable.
TR_SW#	O	120	Transmit & Receive Switch Control. Active low.
TR_SW	O	119	Transmit & Receive Switch Control. Active High.
PA_PE	O	122	Power Amplifier control pin,. Active high.
RF_PE	O	121	Power enable pin to RF and IF components.
PE1	O	13	Power enable1 for I/Q Modulation/Demodulation
PE2	O	15	Power enable2 for I/Q Modulation /Demodulation

Power Control interface signals group

2.7 Synthesizer control signal Interface pins group

SIGNAL	TYPE	PIN NO.	DESCRIPTION
SYNDATA	O	128	Serial data for front-end chip synthesizer.
SYNCLK	O	127	Serial clock for front-end chip synthesizer.
LE_IF#	O	123	Load (latch) Enable to IF synthesizer. MAC selects IF as target for serial access.
LE_RF#	O	124	Load (latch) Enable RF synthesizer. MAC selects RF as target for serial access

Channel Activity Status Interface pins group

2.8 Miscellaneous pins group

SIGNAL	TYPE	PIN NO.	DESCRIPTION
RSTPHY#	O	14	MAC will reset BBP when it monitors the system-reset occurred. Due to power management issue, MAC will drive BBP into stand-by mode by RSTPHY# signal driven low for Intersil-like BBP or high for RFMD-like BBP.
HbusMode	I/PU	106	Pull high with VDD2 for PCI/CARDBUS operation Pull low with VSS2 for PCMCIA operation.
CBSEL	I/PD	71	Pull high for CRADBUS operation. In Cardbus mode, Both HbusMode and CBSEL are also pulled high.
BBPMODE[1:0]	I/PU	108,109	BBP interface selection. 2'b00: For Intersil-like interface. 2'b01: For RFMD-like interface. 2'b10: Reserved 2'b11: For RaLink BBP.



AX81190 PCI/CARDBUS/PCMCIA Bus WLAN MAC

LED1	O	17	Indicates in transmitted state.
LED2	O	19	Indicates in received state.
EEPROM DIS	I/PD	97	Reserved, pull down with VSS2 for normal operation.
MT[1:0]	I/PD	99,100	Memory Test, pull down with VSS2 (2'b00) for normal operation.
GPIO[5:0]	I/O/PD	21,22,102, 103,104,105	General pins are controlled by software.
VDD1	P	11,16,25,38, 54,72,79,110, 126	Power Supply: +2.5V DC.
VDD2	P	20,31,48,60, 82,87,98,116	Power Supply: +3.3V DC.
VSS1	P	3,18,27,35,51 ,57,67,90,107 ,112	Ground pin for +2.5V.
VSS2	P	6,23,29,43,75 ,95,101,118	Ground pin for +3.3V.

Miscellaneous pins group



3.0 Registers Operation

R Read Only
W Write Only
WO Write "one" Only

RC Read to Clear
WC Write "one" to Clear

3.1 PCI Configuration Register

3.1.1 Device vendor register -- offset 00h

Field	R/W	Default	Description
31:16	R	1190h	Indicate the Device ID in PCI system.
15:0	R	125Bh	ASIX Vendor ID.

3.1.2 Command register – offset 04h

Field	R/W	Default	Description
15-10	R	6'b000000	Reserved.
9	R	0	Fast back-to-back transactions. <u>Always 0</u> , this function is not supported.
8	R	0	SERR enable function. <u>Always 0</u> , this function is not supported.
7	R	0	Address/data step function. <u>Always 0</u> , this function is not supported.
6	R/W	0	Parity error response function. If set high, interface will response parity error message via PERR_. If this bit is 0, interface will ignore parity error. Default:0
5	R	0	VGA snooping. <u>Always 0</u> , not supported.
4	R	0	Memory write and invalid command. <u>Always 0</u> , interface will not generate this command.
3	R	0	Special cycle response. <u>Always 0</u> , interface ignores all special cycle.
2	R	0	Bus master control. Interface does not support master function.
1	R/W	0	Memory space response enable.
0	R/W	0	I/O space control. If it is set to '0', interface does not response io access, otherwise interface will response io access.

3.1.3 Status register – offset 06h

Field	R/W	Default	Description
15	R/WC	0	PERR_ detected. Set to '1' whenever parity error is detected, Write '1' to clear.
14	R	0	SERR_ detected.
13	R	0	Receive master abort.
12	R	0	Receive target abort.
11	R	0	Target abort.
10:9	R	0	Timing.
8	R	0	PERR_ reported.
7	R	0	Fast back-to-back capability, Always 0.
6	R	0	User define features. Always 0.
5	R	0	66MHz capability. Always 0, interface is not supported 66 MHz.
4	R	0	Capability bit. Always 0.
3:0	R	4'b0000	Reserved. Always 4'b0000

3.1.4 Revision ID register – offset 08h



Bit	R/W	Default	Description
7:0	R	00h	Current revision, the value is 01h now.

3.1.5 Class code register – offset 09h

Bit	R/W	Default	Description
23:0	R	020000h	Ethernet Network controller.

3.1.6 Base IO address register – offset 10h

Bit	R/W	Default	Description
31:16	R	0	Reserved
15:7	R/W	0	To be mapped in 64K in space
6:1	R	0	Reserved.
0	R	1	IO space indicator.

3.1.7 Base Memory address register – offset 14h

Bit	R/W	Default	Description
31:8	R/W	0	To 4G memory space.
7:0	R	0	Reserved.

3.1.8 CIS pointer – offset 28h

3.1.9 Subsystem ID – 2Ch

Bit	R/W	Default	Description
31:16	R/W	1190h	Download from EEPROM when power on.
15:0	R/W	125Bh	Download from EEPROM when power on.

3.1.10 Interrupt register – 3Ch

Bit	R/W	Default	Description
15:8	R	01h	Interrupt pin assigned. The value is always 01h.
7:0	R/W	FFh	Interrupt line routing information. Default value is FFh.



3.2 PCMCIA Configuration Register

In PCMCIA application, there are four registers, 800h, 802h, 804, and 806h located in attribute memory.

3.2.1 COR register – 0800h

Field	R/W	Default	Description
7	R/W	0	Soft reset enable. Set to '1' to reset MAC core. MAC will reset this bit if it finished reset operation. This function is replaced with base e register.
6	R	0	Reserved
5:0	R/W	0	Configure index, Set to non-zero's bit to enable IO transfer.

3.2.2 CCR register – 0802h

Field	R/W	Default	Description
7:6	R	0	Reserved
5	R	0	IOIS8 indicator. MAC always responses 16-bit access except the memory access.
4:	R	0	Reserved.

3.2.3 IO base (LSB) – 0804h

Field	R/W	Default	Description
7:0	R/w	0	For io base address pointer (LSB)

3.2.4 IO base (MSB) – 0806h

Field	R/W	Default	Description
7:0	R/w	0	For io base address pointer (MSB)



3.3 IO port

3.3.1 CSR index port

base

Field	R/W	Default	Description
15-8	R	0	Reserved
7-0	R/W	0	Selects the CSR location of MAC to be accessed.

3.3.2 CSR data port

base + 2

Field	R/W	Default	Description
15-0	R/W	0	16-bit data port for MAC control and status register accesses.

3.3.3 Tx Data access control port

base + 4

Field	R/W	Default	Description
15	R/W	0	Enable for data burst. Driver can set this bit to '1'. Hardware will automatically increase address when driver accesses Tx data buffer port.
14:12	R/W	0	3'b111: for beacon information to be transmitted 3'b110: for probe response frame to be transmitted Others : for general data to be transmitted. AX81190 support 6 pages for general data using.
11:0	R/W	0	Address for internal TX memory access. (byte access)

3.3.4 Tx data buffer port

base + 6

Field	R/W	Default	Description
15-0	R/W	0	16-bit port for MAC internal tx data buffer access

3.3.5 Rx Data access control port

base + 8

Field	R/W	Default	Description
15	R/W	0	Burst enable for access RX buffer.
14:11	R/W	0	RX buffer page pointer. There are 10 pages available and valid range is from 0 to 9.
10:0	R/W	0	Address for internal RX buffer access. (word access)

3.3.6 Rx data buffer port

base + ah

Field	R/W	Default	Description
15-0	R/W	0	16-bit port for MAC internal rx data buffer access

3.3.7 Soft reset port

base + eh

Field	R/W	Default	Description
15:2	R/W	0	Reserved
1	R/W	0	If set to '1', MAC will reset BBP. This bit will be reset when it was finished operation.
0	R/W	0	If set to '1', MAC will reset internal core. When MAC finished reset itself, it will reset this bit to '0'. The reset only affected buffer management and protocol control unit.

3.3.8 Interrupt status port

base + 10h

Field	R/W	Default	Description
15:11	R	0	Reserved
10	R/WC	0	TX packet length error.
9	R	0	Reserved
8	R/WC	0	TBTT time-out indication.



AX81190 PCI/CARDBUS/PCMCIA Bus WLAN MAC

7	R/WC	0	RX data indicator. When MAC has received data from another station and these are been stored in internal buffer. This bit will be set to 1 while data is completed in buffer. MAC will interrupt host to check the status.
6	R/WC	0	TX data complete indicator. When MAC has successfully sended out data and it obtains a ACK returned or no needs ACK, this bit will be set to high. Driver can approach this bit to determine the status.
5	R/WC	0	Tx fail. When MAC issues a transmit frame and finds no response corresponding frame.
4	R/WC	0	Tx beacon finish.
3	R/WC	0	Protocol change event. This bit indicates there is a protocol changed.
2	R/WC	0	ATIM window end.
1	R/WC	0	Soft reset complete.
0	R/WC	0	Rx buffer full indication.

3.3.9 Interrupt mask port

base + 12h

Field	R/W	Default	Description
15:11	R	0	Reserved
10	R/W	0	Set '1' to enable corresponding event that generates interrupt.
9	R	0	Reserved
8	R/W	0	Set '1' to enable corresponding event that generates interrupt.
7	R/W	0	Set '1' to enable corresponding event that generates interrupt.
6	R/W	0	Set '1' to enable corresponding event that generates interrupt.
5	R/W	0	Set '1' to enable corresponding event that generates interrupt.
4	R/W	0	Set '1' to enable corresponding event that generates interrupt.
3	R/W	0	Set '1' to enable corresponding event that generates interrupt.
2	R/W	0	Set '1' to enable corresponding event that generates interrupt.
1	R/W	0	Set '1' to enable corresponding event that generates interrupt.
0	R/W	0	Set '1' to enable corresponding event that generates interrupt.

3.3.10 Rx page status port

base + 14h

Field	R/W	Default	Description
15:10	R	0	Reserved
9	R/WC	0	This bit indicates that there is a packet stored in page9 of rx buffer.
8	R/WC	0	This bit indicates that there is a packet stored in page8 of rx buffer.
7	R/WC	0	This bit indicates that there is a packet stored in page7 of rx buffer.
6	R/WC	0	This bit indicates that there is a packet stored in page6 of rx buffer.
5	R/WC	0	This bit indicates that there is a packet stored in page5 of rx buffer.
4	R/WC	0	This bit indicates that there is a packet stored in page4 of rx buffer.
3	R/WC	0	This bit indicates that there is a packet stored in page3 of rx buffer.
2	R/WC	0	This bit indicates that there is a packet stored in page2 of rx buffer.
1	R/WC	0	This bit indicates that there is a packet stored in page1 of rx buffer.
0	R/WC	0	This bit indicates that there is a packet stored in page0 of rx buffer.

3.3.11 Tx page status port1

base + 16h

Field	R/W	Default	Description
15	R/WO	0	Beacon packet indicator. If set to '1' means data occupied the beacon buffer. Driver set this bit to '1' and AX81190 will reset it if it transmits out the beacon packet.
14:6	R	0	Reserved.
5	R/WO	0	If set to '1' means data occupied the page5 of tx buffer. Driver set this bit to '1' and AX81190 will reset it if it transmits out the packet.
4	R/WO	0	If set to '1' means data occupied the page4 of tx buffer. Driver set this bit to '1' and AX81190 will reset it if it transmits out the packet.
3	R/WO	0	If set to '1' means data occupied the page3 of tx buffer. Driver set this bit to '1' and AX81190 will reset it if it transmits out the packet.



AX81190 PCI/CARDBUS/PCMCIA Bus WLAN MAC

2	R/WO	0	If set to '1' means data occupied the page2 of tx buffer. Driver set this bit to '1' and AX81190 will reset it if it transmits out the packet.
1	R/WO	0	If set to '1' means data occupied the page1 of tx buffer. Driver set this bit to '1' and AX81190 will reset it if it transmits out the packet.
0	R/WO	0	If set to '1' means data occupied the page0 of tx buffer. Driver set this bit to '1' and AX81190 will reset it if it transmits out the packet.

3.3.12 Tx page status port2

base + 18h

Field	R/W	Default	Description
15:6	R	0	Reserved
5	RC	0	If set to '1' means page5 fail in transmittance.
4	RC	0	If set to '1' means page4 fail in transmittance.
3	RC	0	If set to '1' means page3 fail in transmittance.
2	RC	0	If set to '1' means page2 fail in transmittance.
1	RC	0	If set to '1' means page1 fail in transmittance.
0	RC	0	If set to '1' means page0 fail in transmittance.

3.3.13 BBP index port

base + 1ah

Field	R/W	Default	Description
15	R/W	0	Write BBP register enable bit. BBP controlling flag (open bit). <u>If set to 1</u> , any access to BBP_data port register will generate serial write cycle between BBP and MAC. When MAC completes the access, it will reset this bit to 0.
14	R/W	0	Read BBP register enable bit. If this bit is set to 1, MAC will generate serial read cycle to BBP. Default is 0. When MAC completes the access, it will reset this bit to 0.
13:8	R/W	0	Reserved
7:0	R/W	0	BBP internal register's index.

3.3.14 BBP data out port

base + 1ch

Field	R/W	Default	Description
15:8	R	0	Reserved
7:0	R/W	0	Contained the data will be out to BBP.

3.3.15 BBP data in port

base + 1eh

Field	R/W	Default	Description
15:8	R	0	Reserved
7:0	R/W	0	Store the data read from BBP internal registers.

3.3.16 Synthesizer control port

base + 20h

Field	R/W	Default	Description
15:9	R	0	Reserved
8	R/W	0	Start program PLL phase
7	R/W	0	IF PLL latch enable. Self-reset if it finished programming IF chip.
6	R/W	0	RF PLL latch enable. Self-reset if it finished. Programming RF chip.
5:0	R/W	14h	Contain bit-length to program PLL of synthesizer. Max value is 32.

3.3.17 Synthesizer data port0

base + 22h

Field	R/W	Default	Description
15:0	R/W	0	The register contains lower 16 bits data that want to program to PLL of synthesizer.

3.3.18 Synthesizer data port1

base + 24h

Field	R/W	Default	Description
15:0	R/W	0	The register contains higher 4 to 16 bits data that want to program to PLL of



			synthesizer.
--	--	--	--------------

3.3.19 EE data port **base + 26h**

Field	R/W	Default	Description
15:0	R/W	0	16 bit data port for serial EEPROM access.

3.3.20 EE cmd/addr port **base + 28h**

Field	R/W	Default	Description
15:13	R/W	0	Command Type. 3'b110 : read 3'b111 : Erase 3'b101 : write 3'b100: erase/write enable
12	R/W	0	Set to '1' to enable write EEPROM, it will be reset if MAC finished the write operation.
11	R/W	0	Set to '1' to enable read EEPROM, it will be reset if MAC finished the read operation. Driver can read base_26 port to get the data.
10	R/W	0	Set to '1' to indicate MAC to verify the write operation.
9:8	R	0	Reserved
7:0	R/W	0	Address for serial EEPROM access. (only support 16 bit data access) 93c56 : use A7 ~ A0, but A7 always is '0'

3.3.21 EE status_type port **base + 2ah**

Field	Type	Default	Description
15:9	R	0	Reserved
8	R	0	If set to '1' means MAC is currently loading data from EEPROM.
5:4	R	2'b01	Serial EEPROM configuration indicator. 2'b01 : 93C56 supported.
3	R	0	Reserved.
2:0	R	3'b001	Serial EEPROM clock rate indicator. 3'b001 : 1MHz..



3.4 MAC Configuration Status Registers

3.4.1 CSR1 – MAC Physical address0 (PADR[15:0])

Field	R/W	Default	Description
15:0	R	0	Physical address register. When power-on, MAC loads data from external EEPROM and update this register once.

3.4.2 CSR2 – MAC Physical address1 (PADR[31:16])

Field	R/W	Default	Description
15:0	R	0	Physical address register. When power-on, MAC loads data from external EEPROM and update this register once.

3.4.3 CSR3 – MAC Physical address2 (PADR[47:32])

Field	R/W	Default	Description
15:0	R	0	Physical address register. When power-on, MAC loads data from external EEPROM and update this register once.

3.4.4 CSR4 – BSSID Matching Register0, BSSID[15:0]

Field	R/W	Default	Description
15:0	R/W	0	This 16-LSB of the 48-bit Address3 matching pattern.

3.4.5 CSR5 – BSSID Matching Register1, BSSID[31:16]

Field	R/W	Default	Description
15:0	R/W	0	This 16-CSB of the 48-bit Address3 matching pattern.

3.4.6 CSR6 – BSSID Matching Register2, BSSID[47:32]

Field	R/W	Default	Description
15:0	R/W	0	This 16-MSB of the 48-bit Address3 matching pattern.

3.4.7 CSR7 ~ CSR9 are reserved.

3.4.10 CSR10 – Multicast filter pattern1

Field	R/W	Default	Description
15:0	R/W	0	This field defines the filtering pattern for multicast frame
Note: When m_csr29 bit6 is enabled, this register will be referred.			

3.4.11 CSR11 – Multicast filter pattern2

Field	R/W	Default	Description
15:0	R/W	0	This field defines the filtering pattern for multicast frame
Note: When m_csr29 bit6 is enabled, this register will be referred.			

3.4.12 CSR12 – Multicast filter pattern3

Field	R/W	Default	Description
15:0	R/W	0	This field defines the filtering pattern for multicast frame
Note: When m_csr29 bit6 is enabled, this register will be referred.			

3.4.13 CSR13 – Multicast filter pattern4

Field	R/W	Default	Description
15:0	R/W	0	This field defines the filtering pattern for multicast frame



Note: When m_ csr29 bit6 is enabled, this register will be referred.

Note: Multicast filter matrix

CSR10[7:0]	7	6	5	4	3	2	1	0
CSR10[15:8]	15	14	13	12	11	10	9	8
CSR11[7:0]	23	22	21	20	19	18	17	16
CSR11[15:8]	31	30	29	28	27	26	25	24
CSR12[7:0]	39	38	37	36	35	34	33	32
CSR12[15:8]	47	46	45	44	43	42	41	40
CSR13[7:0]	55	54	53	52	51	50	49	48
CSR13[15:8]	63	62	61	60	59	58	57	56

3.4.12 CSR14 ~ CSR15 are reserved.

3.4.16 CSR16 – clock pattern

Field	R/W	Default	Description
15:12	R	0	Reserved.
11:8	R/W	fh	RTS-CTS max duration
7:0	R/W	10h	Set to 10h if use 33Mhz host clock. Set to 16h if use 44Mhz host clock.

3.4.17 CSR17 – Wait md rdy duration

Field	R/W	Default	Description
7:0	R/W	14h	The duration mac waited for the md rdy, if there is PLCP field is found.

3.4.18 CSR18 – Short Interframe space timing register ,SIFS

Field	R/W	Default	Description
15:0	R/W	0Ah	This field defines the timing slice of short interframe space timing. The timing unit is 1us.

3.4.19 CSR19 – Distributed Interframe space timing register, DIFS/PIFS

Field	R/W	Default	Description
15:0	R/W	20h	This field defines the timing slice of DIFS space timing. The timing unit is 1us.

3.4.20 CSR20 ~ CSR 21 – Reserved.

3.4.22 CSR22 – SlotTime Register (SLOT)

Field	R/W	Default	Description
15:0	R/W	14h	The SLOT time register is written to by some proper values by the driver. It determines the unit of the backoff time. The unit of the register value is in μ s.

3.4.23 CSR23 – Backoff timing

Field	R/W	Default	Description
15:0	R	0	To show the backoff timing of MAC.

3.4.24 CSR24 – RF3000 modulation duration (Testing)

Field	R/W	Default	Description
15:0	R/W	4000h	Available when RF3000 BBP is used.

3.4.25 CSR25 – Power Testing and misc

Field	R/W	Default	Description
-------	-----	---------	-------------



15	R/W	0	1: Tx power enable. 0: None
14	R/W	0	Tx power pattern.
13	R/W	0	1: Tx power toggle enable. 0: None
12	R/W	0	Reserved
11	R/W	0	1: enable software control 0: None
10	R/W	0	Reserved
9	R/W	0	Reserved
8	R/W	0	Software control SynData
7	R/W	0	Software control SynCLK
6	R/W	0	Software control LE_RF#
5	R/W	0	Software control RF_PE
4	R/W	0	Software control PE2.
3	R/W	0	Software control PE1
2	R/W	0	Software control PA_PE
1	R/W	0	Software control RX_PE
0	R/W	0	Software control TX_PE

3.4.26 CSR26 – TXVGC adjust register (support RF3000 only)

Field	R/W	Default	Description
7	R/W	0	0: long preamble 1: short preamble
6:1	R/W	25h	Gain setting for transmission.
0	R/W	0	Scrambler indication. 0 : enable 1: Disable

3.4.27 CSR27 – Tx Beacon/probe response enable register

Field	R/W	Default	Description
7:2	R	0	Reserved.
1	R/W	0	1: Enable MAC to grab data from beacon buffer and transmit the data. The data is especially for <i>probe response frame</i> used and max length can not exceed <i>512 byte</i> .
0	R/W	0	1: Enable MAC to grab data from beacon buffer and transmit the data. MAC will reset this bit if it finished the transmittance. The max length can not exceed <i>512 byte</i> .

3.4.28 CSR28 – TBTT Compensation Register

Field	R/W	Default	Description
15:10	R	0	Reserved
9:0	R/W	0	This 10-bit register, which is used to compensate the calculation delay of TBTT generation circuit. It can also be used to compensate the driver's processing delay to generate a beacon frame. The unit of the value is in μs .

3.4.29 CSR29 – Rx filtering Register

Field	RW	Default	Description
15:11	R/W	0	Reserved
10	R/W	0	Multicast algorithm selection. 0: select XOR 1: select CRC32.
9	R/W	0	1: Enable Rx length filtering.
8	R/W	0	1: Force rx enable. (Always enable RX_PE to be high)



7	R/W	0	Enable broadcast reception. If set to 0, all broadcast frames will be dropped.
6	R/W	0	Enable multicast filtering. If set to 1, only the multicasts whose Address1 field matches the matching criteria will be passed to the driver. The default is 0.
5	R/W	0	Enable multicast reception. If set to 1, multicast frames will be received, and no logical address matching will be performed.
4	R/W	0	Reserved
3	R/W	0	CRC32 check enabled. If set to 1, the CRC32 fields with will be verified.
2	R/W	0	Control frame enable. If set to 1, all control frames received will be passed to the driver.
1	R/W	0	Promiscuous mode enabled. If set to 1, all data/mgmt frames will be passed to the driver.
0	R/W	0	RX enable. This bit defines whenever MAC can receive data. Driver must set this bit to '1' to enable receive mode.

3.4.30 CSR30 – TX Power Ramp-up Control Register1

Field	RW	Default	Description
15:0	R/W	0Ah	This field defines the TX_PE lagged time when RX_PE was driven low.

3.4.31 CSR31 – TX Power Ramp-up Control Register2

Bit	RW	Default	Description
15:0	R/W	14h	This field defines pe2 lagged time when rx_pe was driven low.

3.4.32 CSR32 – TX Power Ramp Control Register3

Bit	R/W	Default	Description
15:0	R/W	1bh	This field defines the pa_pe lagged time when rx_pe was driven low.

3.4.33 CSR33 – TX Power Ramp Control Register4

Bit	R/W	Default	Description
15:0	R/W	46h	This field defines the tr_sw lagged time when rx_pe was driven low.

3.4.34 CSR34 – TX Power Ramp Control Register5

Bit	R/W	Default	Description
15:0	R/W	bdh	This field defines the duration before RX_PE asserted. The start point is based on last bit to be transmitted.

3.4.35 CSR35 – BeaconPeriod (BP)

Field	R/W	Default	Description
15:0	R/W	0200h	This 16 bit register, which is used to uniquely define the Target Beacon Transmission Time (TBTT). The unit of the value is Kus.

3.4.36 CSR36 – Tx Retry counter

Field	RW	Default	Description
7:0	R/W	10h	Tx Retry counter. This register defines the retry number. MAC will assert a packet, if there is no relative frame returned.

3.4.37 CSR37 – MAC feature register

Field	R/W	Default	Description
15	R/W	0	The duration field of RTS frame is from data or information header. 1: From data. 0: From information header.
14	R/W	0	1: Enable NAV mechanism for channel status.



AX81190 PCI/CARDBUS/PCMCIA Bus WLAN MAC

13	R/W	1	1: Disable to set Intersil 3861 CR31 register 0: MAC will set the Intersil 3861 before transmittance.
12	R/W	0	PE2 polarity.
11	R/W	0	1 : to reset TSF timer, MAC will clear this bit when the reset is finished.
10	R/W	0	1:Tx stop normal page. Driver set this bit to stop the transmittance.
9	R/W	0	1:Tx stop urgent page. Driver set this bit to stop the transmittance.
8	R/W	1	Inbuf overflow protect. 1: Protect when inbuf is full. Data will not be written to inbuf. 0: No protect. Data will be written to inbuf, regardless of inbuf whether it is full or not.
7	R/W	0	Backoff procedure disable. When set to 1, backoff procedure will ignore. MAC will be prepared to request medium immediately whenever it has data to be sent.
6	R/W	0	CCA Enable.
5	R/W	0	CCA polarity for channel available. (RFMD)
4	R/W	0	To indicate MAC employs 3-wire or 4-wire approach to program BBP. 0: 3-wire, Use CS#, SCLK and SD signals. 1: 4-wire, Use CS#, SCLK, SD and RW# signals.
3	R/W	0	1: Latch SQ enable. 0: Nothing
2	R/W	0	1: Latch RSSI enable. 0: Nothing
1	R/W	1	PE1 polarity. 0: Active low 1: Active high.
0	R/W	0	RF_PE (Radio-PD) polarity. 0: Active low 1: Active high

3.4.38 CSR38 is Reserved

3.4.39 CSR39 – Transmit page control register

Field	R/W	Default	Description
7	R/W	0	If this bit is set, it claims this transaction has the priority; otherwise, it is a normal transmittance.
6:3	R/W	0	Reserved
2:0	R/W	0	Driver set this field to claim which the page data will be transmitted. 2'b000: page0 to be transmitted. 2'b001: page1 to be transmitted. 2'b010: page2 to be transmitted. 2'b011: page3 to be transmitted. 2'b100: page4 to be transmitted. 2'b101: page5 to be transmitted.

3.4.40 CSR40 – TX Rate control register.

Field	R/W	Default	Description
15	R	0	Reserved
14:12	R/W	3'b000	RTS speed control 3'b000: auto 3'b001: 1M 3'b010: 2M 3'b011: 5.5M 3'b100: 11M Others: reserved
11	R	0	Reserved
10:8	R/W	3'b000	ACK/CTS speed control



			3*b000: auto 3*b001: 1M 3*b010: 2M 3*b011: 5.5M 3*b100: 11M Others: reserved
7:5	R	0	Reversed.
4		0	Tx/Rx filter CMF weight. 0 = U.S. 1=Japan.
3	R/W	0	Select preamble mode 0= Normal, long preamble 1= short preamble and header mode.
2:0	R	0	Reserved
Bit7 ~ bit0 is only for Intersil 3861/3863.			

3.4.41 CSR41 – response time-out register

Field	R/W	Default	Description
15:0	R/W	0145h	MAC will count the time when it desires CTS/ACK returned. The time unit is us.

3.4.42 CSR42 – RSSI-SQ location register

Field	R/W	Default	Description
15:8	R/W	72h	SQ location in BBP
7:0	R/W	7Ch	RSSI location in BBP.
For 3861 set to 727Ch For R3000 set to xx03h.			

3.4.43 CSR43 – TSF compensate register

Field	R/W	Default	Description
15	R/W	0	This bit defines how many us need to compensate the TSF timer when MAC transmitted beacon frame. 0: MAC will add bit[14:0] value to TSF timer. 1: MAC will deduct bit[14:0] value from TSF timer and inserted the final value to frame body of beacon.
14:0	R/W	0	Compensate value for TSF. This unit is us.

3.4.44 CSR44 – Calibration adjust register

Field	R/W	Default	Description
15	R/W	0	Calibration enable. If set, MAC will drive cal_en pin. Driver set this bit to 1 to enable calibration mode. If MAC finished calibration, it will reset it to 0.
14	R/W	0	Set to '1' to enable cal_en until it's cleared.
13:0	R/W	64h	This field defines how many us of calibration mode driven by MAC when bit15 is set to '1'

3.4.45 CSR45 – BBP PLCP Service/Signal field location register (for Intersil 3861/3863)

Field	R/W	Default	Description
15:8	R/W	0Ch	This field defines the index of BBP TX service field register.
7:0	R/W	0Ah	This field defines the index of BBP TX signal field register.

3.4.46 CSR46 – BBP PLCP Length field location register (for Intersil 3861/3863)



Field	R/W	Default	Description
15:8	R/W	10h	This field defines the index of BBP TX length field, Low, register.
7:0	R/W	0Eh	This field defines the index of BBP TX length field, High, register.

3.4.47 CSR47 is Reserved

3.4.48 CSR48 – Software reset duration

Field	R/W	Default	Description
15:0	R/W	200h	This register defines the duration of MAC generates the reset signal.

3.4.49 CSR49 – CFP duration register

Field	R/W	Default	Description
15:0	R/W	0	CFP duration is set by driver. The time unit is K μ s.

3.4.50 CSR50 – ATIM duration register

Field	R/W	Default	Description
15:0	R/W	0	ATIM duration is set by driver. The time unit is K μ s..

3.4.51 CSR51 – 802.11 protocol status

Field	R/W	Default	Description
7:2	R	0	Reserved
1	R/W	0	1: ATIM start 0: Nothing Driver set this bit to claim the beginning of ATIM, hardware will reset it and generate interrupt when the ATIM is expired.
0	R/W	0	1: PCF status 0: DCF status Driver set this bit to indicate MAC behavior. MAC will reset from PCF to DCF, if it recognizes CF end packet.

3.4.52 CSR52 – MAC mode status

Field	R/W	Default	Description
7	R/W	0	This bit indicates MAC to response CF_ACK when <u>MAC is as AP</u> in PCF. 0: None 1: enable
6	R/W	0	1: Driver issue beacon enable. Driver also needs to set M_CSR27 bit0 to assert a beacon transmittance.
5	R/W	0	1: Hardware auto generate beacon enable.
4	R/W	0	1: Enable hardware automatically parse beacon frame.
3	R/W	0	1: Enable ATIM window counter begin to down count.
2	R/W	0	1: Enable CFP counter begin to down count
1	R/W	0	1: AP mode
0	R/W	0	1: IBSS mode

3.4.53 CSR53 – BBP mode

Field	R/W	Default	Description
7:2	R	0	Reserved
1:0	R	0	00 : Support Intersil 3861/3863 BBP 01: Support RFMD RF3000 BBP 10: Reserved. 11: For RaLink 2430 BBP



3.4.54 CSR54 – SPI chip address

Field	R/W	Default	Description
15:8	R/W	0	Reserved
7:0	R/W	40h	Chip address for RF3000. Employ bit7 ~ bit1, bit0 is r/w control
Support RFMD R3000 SPI interface			

3.4.55 CSR55 ~ CSR59 reserved .

3.4.60 CSR60 CRC32 counter

Field	R/W	Default	Description
15:0	R	0	This counter defines the number of CRC32.

3.4.61 CSR61 is reserved.

3.4.62 CSR62 – NAV timer

Field	R/W	Default	Description
15:0	R	0	This timer is updated by RTS, CTS and DATA from arrive at the station. RTS, CTS and DATA frames include a field that indicates the expected length of the RTS-CTS-DATA-ACK exchange. The MAC used this value to update NAV timer. If any portion of RTS-CTS-DATA-ACK exchange is missing, then a MAC timer will timeout and the NAV is reset to zero. The time unit is us.

3.4.63 CSR63 – TSF timer register0 (TSFR[15:0])

Field	R/W	Default	Description
15:0	R	0	Local timer. MAC will adopt the timer information in beacon or in probe response (from AP). If MAC's TSF timer is different from the timestamp in received beacon, MAC would set TSF timer when it received.

3.4.64 CSR64 – TSF timer register1 (TSFR[31:16])

Field	R/W	Default	Description
15:0	R	0	Local timer. MAC will adopt the timer information in beacon or in probe response (from AP). If MAC's TSF timer is different from the timestamp in received beacon, MAC would set TSF timer when it received.

3.4.65 CSR65 – TSF timer register2 (TSFR[47:32])

Field	R/W	Default	Description
15:0	R	0	Local timer. MAC will adopt the timer information in beacon or in probe response (from AP). If MAC's TSF timer is different from the timestamp in received beacon, MAC will set TSF timer as it received.

3.4.66 CSR66 – TSF timer register3 (TSFR[63:48])

Field	R/W	Default	Description
15:0	R	0	Local timer. MAC will adopt the timer information in beacon or in probe response (from AP). If MAC's TSF timer is different from the timestamp in received beacon, MAC will set TSF timer as it received.

3.4.67 CSR67 ~ CSR69 Reserved.

3.4.70 CSR70 – Not my unicast frame counter

Field	R/W	Default	Description
15:0	R	0	The counter is created by 1 when mac receives a data or management frame that does



			not hit to me. (not included control frame)
--	--	--	---

3.4.71 CSR71 – broadcast and multicast counter

Field	R/W	Default	Description
15:0	R	0	The counter is creased by 1 when mac receives a broadcast or multicast (not my) frame.

3.4.72 CSR72 – RSSI-SQ value

Field	R/W	Default	Description
15:8	R/W	0	SQ value from BBP, if m_csr37 bit3 is set to ‘1’
7:0	R/W	0	This field defines the RSSI value from BBP when m_csr37 bit2 is set to ‘1’. Its range is from 0 to 255 dB.

3.4.73 CSR73 – Outbuf/Inbuf current page pointer

Field	R/W	Default	Description
15	R	0	Current transmission.
14	R	0	Driver starts TX. (data is not yet transmitted by MAC)
13	R	0	Priority Queue status. 1: Queue is not empty. 0: Queue is empty.
12	R	0	Normal queue status. 1: Queue is not empty. 0: Queue is empty.
11:10	R	0	Reserved
9:8	R	0	Outbuf current page pointer.
7:3	R	0	Reserved
2:0	R/W	0	Point to the next page that is written to inbuf .

3.4.74 CSR74: TX Power Ramp-down Control Register1

Bit	R/W	Default	Description
15:0	R/W	5ah	This field defines the duration before TR_SW released. The start point is based on last bit to be transmitted. It is about 4.04 us.

3.4.75 CSR75: TX Power Ramp-down Control Register2

Bit	R/W	Default	Description
15:0	R/W	8ah	This field defines the duration before PA_PE released. The start point is based on last bit to be transmitted. It is about 6.2us.

3.4.76 CSR76: TX Power Ramp-down Control Register3

Bit	R/W	Default	Description
15:0	R/W	E0h	This field defines the duration before PE2 released. The start point is based on last bit to be transmitted. It is about 6.5 we.

3.4.77 CSR77: TX Power Ramp-down Control Register4

Bit	R/W	Default	Description
15:0	R/W	f0h	This field defines the duration before TX_PE released. The start point is based on last bit to be transmitted. It is about 6.92us.

3.4.78 CSR78: RX PE de-asserted duration

Bit	R/W	Default	Description



AX81190 PCI/CARDBUS/PCMCIA Bus WLAN MAC

15:0	R/W	5bh	This field defines RX_PE de-asserted duration in RX state ending. In RX state, RX_PE will be high until the receive finished. If there is no any data to be transmitted, the RX_PE will be de-asserted about 4.1 us then asserted. The duration is about 3.9 ~ 4.2 us.
------	-----	-----	---

3.4.79 CSR79: Min size of RX packet

Bit	R/W	Default	Description
15:0	R/W	15	This register defines the min packet size of RX

3.4.80 CSR80: GPIO status control

Bit	R/W	Default	Description
7:6	R	2'b00	Reserved
5	R/W	1	0: Enable GOIP5 as output
4	R/W	1	0: Enable GOIP4 as output
3	R/W	1	0: Enable GOIP3 as output
2	R/W	1	0: Enable GOIP2 as output
1	R/W	1	0: Enable GOIP1 as output
0	R/W	1	0: Enable GOIP0 as output

3.4.81 CSR81: GPIO data port

Bit	R/W	Default	Description
15:14	R	2'b00	Reserved
13:8	R/W	5'h0	The data will to be output from GPIO[5:0], if the respective bit is set.
7:6	R	2'b00	Reserved
5:0	R	5'h0	Indicate the status from GPIO[5:0] pin.

3.4.82 CSR82: wep control

Bit	R/W	Default	Description
7:3	R	0	Reserved
2	R/W	0	0: 64 bit wep key 1: 128 bit wep key
1	R/W	0	1: Enable RX wep(decryption)
0	R/W	0	1: Enable TX wep(encryption)

3.4.83 WEP key matrix (csr83 ~ csr110, 16 bit registers)

	128 bit						
	64 bit						
Key ID0	csr83	csr84	csr85	csr86	csr87	csr88	csr89[7:0]
Key ID1	csr90	csr91	csr92	csr93	csr94	csr95	csr96[7:0]
Key ID2	csr97	csr98	csr99	csr100	csr101	csr102	csr103[7:0]
Key ID3	csr104	csr105	csr106	csr107	csr108	csr109	csr110[7:0]

Note: In 64-bit mode, csr85, csr92, csr99, csr106 only used bit7 ~ b0



4.0 PCMCIA Device Access Functions

The AX81190, as a PCMCIA I/O device, needs support both Attribute Memory access function and I/O access function. The Access methods are described as the following sections.

4.1 Attribute Memory access functions.

Attribute Memory Read function

Function Mode	REG#	CE2#	CE1#	SA0	OE#	WE#	D[15:8]	D[7:0]
Standby Mode	X	H	H	X	X	X	High-Z	High-Z
Byte Access (8 bits)	L	H	L	L	L	H	High-Z	Even-Byte
	L	H	L	H	L	H	High-Z	Not Valid
Word Access (16 bits)	L	L	L	X	L	H	Not Valid	Even-Byte
Odd Byte Only Access	L	L	H	X	L	H	Not Valid	High-Z

Attribute Memory Write function

Function Mode	REG#	CE2#	CE1#	SA0	OE#	WE#	SD[15:8]	SD[7:0]
Standby Mode	X	H	H	X	X	X	X	X
Byte Access (8 bits)	L	H	L	L	H	L	X	Even-Byte
	L	H	L	H	H	L	X	X
Word Access (16 bits)	L	L	L	X	H	L	X	Even-Byte
Odd Byte Only Access	L	L	H	X	H	L	X	X

4.2 I/O access functions.

I/O Read function

Function Mode	REG#	CE2#	CE1#	SA0	OE#	WE#	D[15:8]	D[7:0]
Standby Mode	X	H	H	X	X	X	High-Z	High-Z
Byte Access (8 bits)	L	H	L	L	L	H	High-Z	Even-Byte
	L	H	L	H	L	H	High-Z	Odd-Byte
Word Access (16 bits)	L	L	L	L	L	H	Odd-Byte	Even-Byte
I/O Inhibit	H	X	X	X	L	H	High-Z	High-Z
Odd Byte Only Access	L	L	H	X	L	H	Odd-Byte	High-Z

I/O Write function

Function Mode	REG#	CE2#	CE1#	SA0	IORD#	IOWR#	D[15:8]	D[7:0]
Standby Mode	X	H	H	X	X	X	X	X
Byte Access (8 bits)	L	H	L	L	H	L	X	Even-Byte
	L	H	L	H	H	L	X	Odd-Byte
Word Access (16 bits)	L	L	L	L	H	L	Odd-Byte	Even-Byte
I/O Inhibit	H	X	X	X	H	L	X	X
Odd Byte Only Access	L	L	H	X	H	L	Odd-Byte	X



5.0 Electrical Specification and Timings

5.1 Absolute Maximum Ratings

Description	Min	Max	Units
Operating Temperature	-40	+125	°C
Storage Temperature	-65	+150	°C
Supply Voltage	-0.3	+4.6	V
Input Voltage	-0.3	5.5	V
Output Voltage	-0.3	4.6	V

Note : Stress above those listed under Absolute Maximum Ratings may cause permanent damage to the device. Exposure to Absolute Maximum Ratings conditions for extended period, adversely affect device life and reliability.
 Note : The power supply voltages must always fulfill $HV_{dd} \geq LV_{dd}$ inequality.

5.2 General Operation Conditions

Description	Min	Tpy	Max	Units
Operating Temperature	0	25	+75	°C
Supply Voltage VDD1	+2.25	+2.5	+2.75	V
Supply Voltage VDD2	+3.00	+3.30	+3.60	V

5.3 DC Characteristics

(V_{dd2}=3.3V, V_{ss2}=0V, T_a=0°C to 75°C)

Description	SYM	Min	Tpy	Max	Units
Low Input Voltage	V _{il}	-0.3		0.8	V
High Input Voltage	V _{ih}	2		5.5	V
Low Output Voltage	V _{ol}	-		0.4	V
High Output Voltage	V _{oh}	2.4		-	V
Input Leakage Current	I _{il}	-1		+1	uA
Output Leakage Current	I _{ol}	-1		+1	uA

Description	SYM	Min	Tpy	Max	Units
Power Consumption	SPt3v		TBD		mA



5.4 A.C. Timing Characteristics

5.4.1 CLOCK

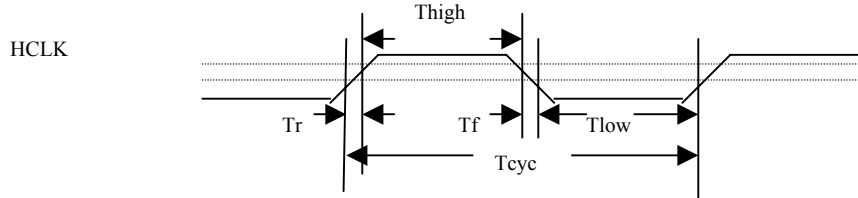

Symbol	Description	Min	Typ.	Max	Units
Tcyc	CYCLE TIME	22	30		ns
Thigh	CLK HIGH TIME	10	15	20	ns
Tlow	CLK LOW TIME	10	15	20	ns
Tr/Tf	CLK SLEW RATE	1	-	4	ns

Note: For PCI/CARDBUS , the clock rate is recommended 33Mhz

5.4.2 PCMCIA Reset Timing

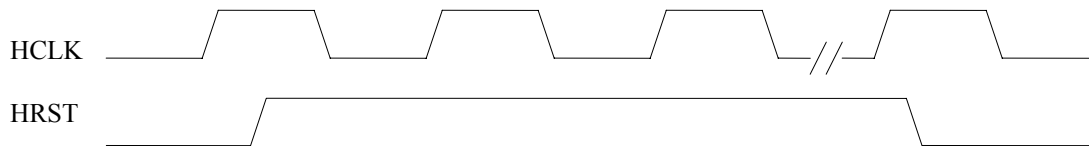

Symbol	Description	Min	Typ.	Max	Units
Trst	Reset pulse width	100	-	-	HClk

PCI Reset Timing

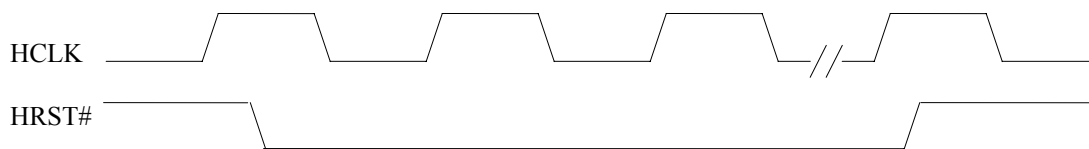

Symbol	Description	Min	Typ.	Max	Units
Trst	Reset pulse width	10	-	-	PCI Clk



5.4.3 PCMCIA Attribute Memory Read Timing

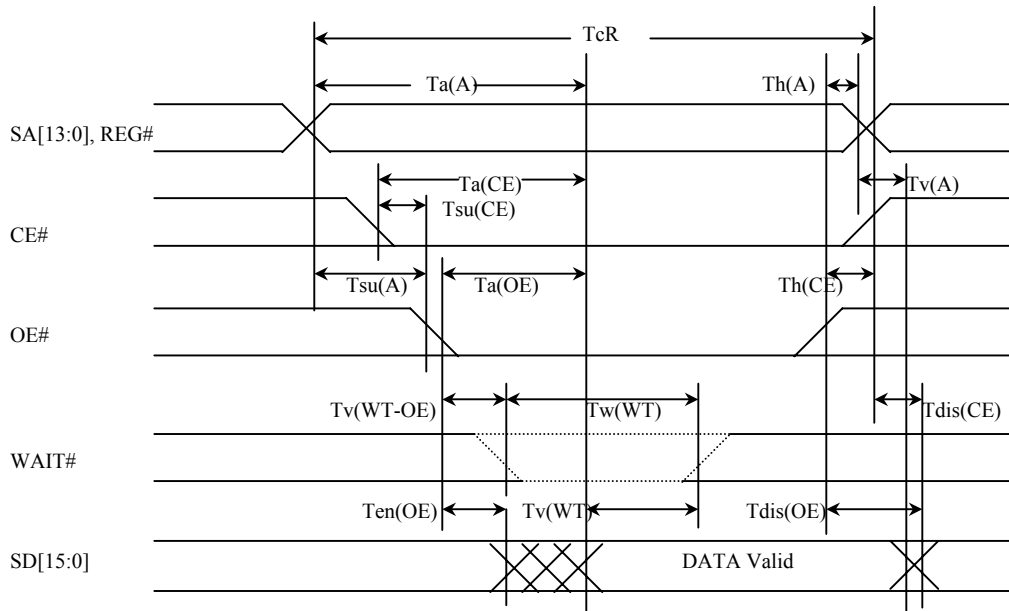

Symbol	Description	Min	Typ.	Max	Units
TcR	READ CYCLE TIME	300	-	-	ns
Ta(A)	ADDRESS ACCESS TIME	-	-	120	ns
Ta(CE)	CARD ENABLE ACCESS TIME	-	-	100	ns
Ta(OE)	OUTPUT ENABLE ACCESS TIME	-	-	100	ns
Tdis(OE)	OUTPUT DISABLE TIME FROM OE#	0.5	-	-	ns
Ten(OE)	OUTPUT ENABLE TIME FROM OE#	-	-	100	ns
Tv(A)	DATA VALID FROM ADDRESS CHANGE	0	-	-	ns
Tsu(A)	ADDRESS SETUP TIME	30	-	-	ns
Th(A)	ADDRESS HOLD TIME	20	-	-	ns
Tsu(CE)	CARD ENABLE SETUP TIME	0	-	-	ns
Th(CE)	CARD ENABLE HOLD TIME	20	-	-	ns
Tv(WT-OE)	WAIT# VALID FROM OE#	-	-	10	ns
Tw(WT)	WAIT# PULSE WIDTH	-	-	200	ns
Tv(WT)	DATA SETUP FOR WAIT# RELEASED	100	-	-	ns



5.4.4 PCMCIA Attribute Memory Write Timing

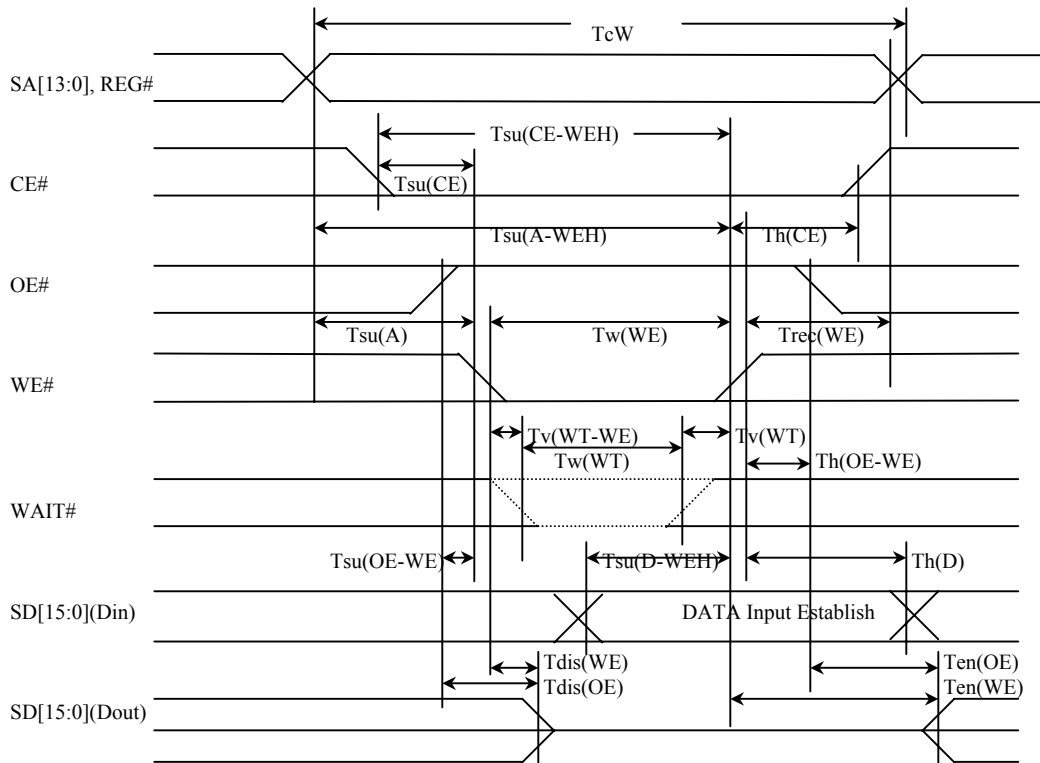

Symbol	Description	Min	Typ.	Max	Units
TcW	WRITE CYCLE TIME	250	-	-	ns
Tw(WE)	WRITE PULSE WIDTH	150	-	-	ns
Tsu(A)	ADDRESS SETUP TIME	30	-	-	ns
Tsu(A-WEH)	ADDRESS SETUP TIME FOR WE#	180	-	-	ns
Tsu(CE-WEH)	CARD ENABLE SETUP TIME FOR WE#	180	-	-	ns
Tsu(D-WEH)	DATA SETUP TIME FOR WE#	80	-	-	ns
Th(D)	DATA HOLD TIME	30	-	-	ns
Trec(WE)	WRITE RECOVER TIME	30	-	-	ns
Tdis(WE)	OUTPUT DISABLE TIME FROM WE#	-	-	5	ns
Tdis(OE)	OUTPUT DISABLE TIME FROM OE#	-	-	5	ns
Ten(WE)	OUTPUT ENABLE TIME FROM WE#	5	-	-	ns
Ten(OE)	OUTPUT ENABLE TIME FROM OE#	5	-	-	ns
Tsu(OE-WE)	OUTPUT ENABLE SETUP TIME FROM OE#	10	-	-	ns
Th(OE-WE)	OUTPUT ENABLE HOLD TIME FROM OE#	10	-	-	ns
Tsu(CE)	CARD ENABLE SETUP TIME	0	-	-	ns
Th(CE)	CARD ENABLE HOLD TIME	20	-	-	ns
Tv(WT-WE)	WAIT# VALID FROM WE#	-	-	15	ns
Tw(WT)	WAIT# PULSE WIDTH	-	-	200	ns
Tv(WT)	WE# HIGH FROM WAIT# RELEASED	0	-	-	ns



5.4.5 PCMCIA I/O Read Timing

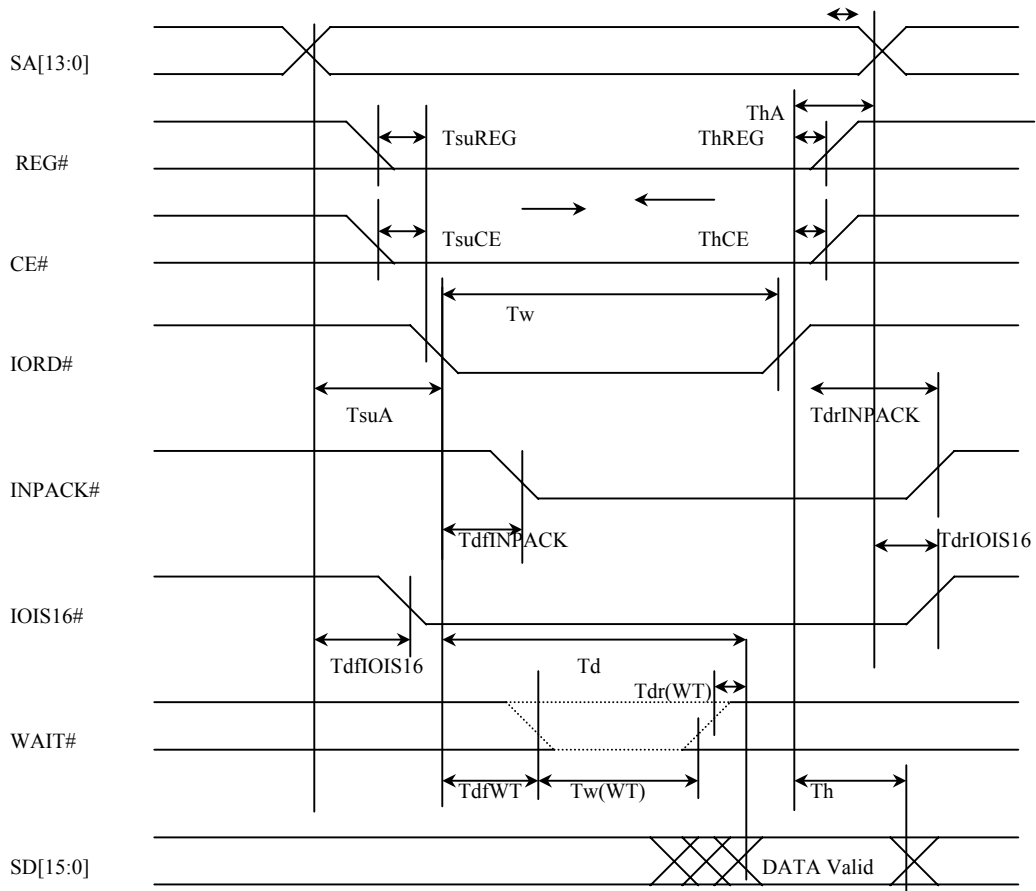

Symbol	Description	Min	Typ.	Max	Units
Td	DATA DELAY AFTER IORD#	-	-	50	ns
Th	DATA HOLD FOLLOWING IORD#	0.5	-	-	ns
Tw	IORD# WIDTH TIME	165	-	-	ns
TsuA	ADDRESS SETUP BEFORE IORD#	70	-	-	ns
ThA	ADDRESS HOLD BEFORE IORD#	20	-	-	ns
TsuCE	CE# SETUP BEFORE IORD#	5	-	-	ns
ThCE	CE# HOLD BEFORE IORD#	20	-	-	ns
TsuREG	REG# SETUP BEFORE IORD#	5	-	-	ns
ThREG	REG# HOLD BEFORE IORD#	0	-	-	ns
TdfINPACK	INPACK# DELAY FALLING FROM IORD#	0	-	10	ns
TdrINPACK	INPACK# DELAY RISING FROM IORD#	-	-	10	ns
TdfIOIS16	IOIS16# DELAY FALLING FROM ADDRESS*	-	-	10	ns
TdrIOIS16	IOIS16# DELAY RISING FROM ADDRESS*	-	-	0	ns
TdfWT	WAIT# DELAY FALLING FROM IORD#	-	-	5	ns
Tdr(WT)	DATA DELAY FROM WAIT# RISING	-	-	0	us
Tw(WT)	WAIT# WIDTH TIME	-	-	100	ns

* Note : The address includes REG# and CE1# signal



5.4.6 PCMCIA I/O Write Timing

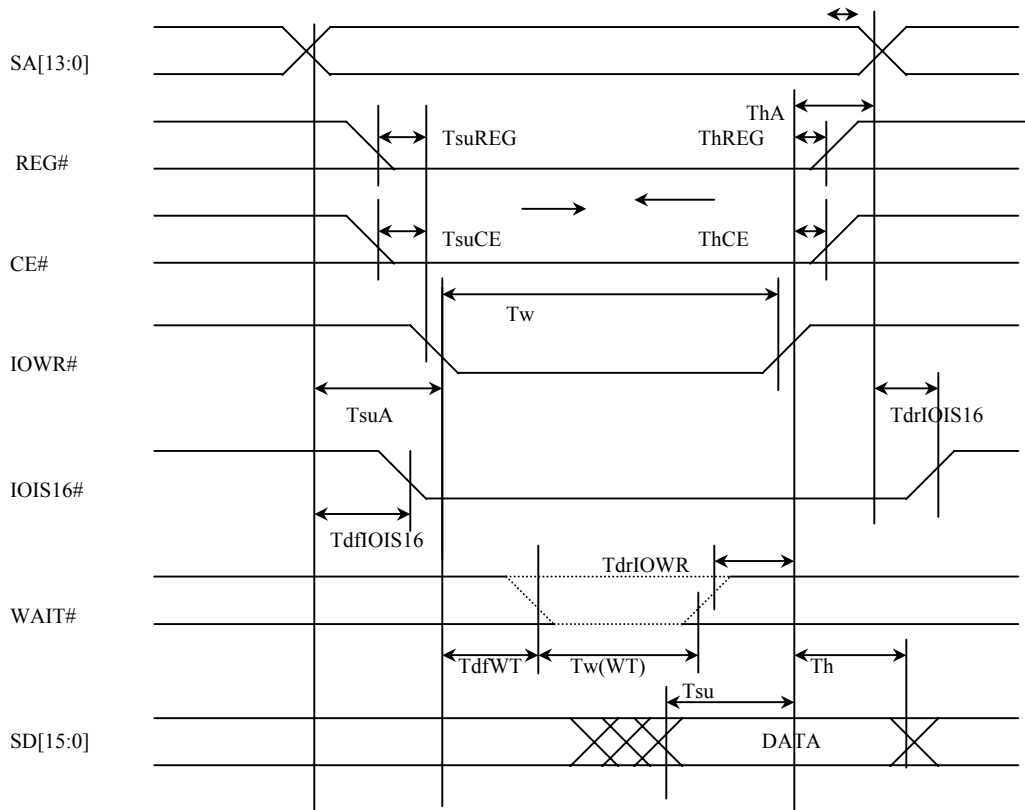

Symbol	Description	Min	Typ.	Max	Units
Tsu	DATA SETUP BEFORE IOWR#	60	-	-	ns
Th	DATA HOLD FOLLOWING IOWR#	30	-	-	ns
Tw	IOWR# WIDTH TIME	165	-	-	ns
$TsuA$	ADDRESS SETUP BEFORE IOWR#	70	-	-	ns
ThA	ADDRESS HOLD BEFORE IOWR#	20	-	-	ns
$TsuCE$	CE# SETUP BEFORE IOWR#	5	-	-	ns
$ThCE$	CE# HOLD BEFORE IOWR#	20	-	-	ns
$TsuREG$	REG# SETUP BEFORE IOWR#	5	-	-	ns
$ThREG$	REG# HOLD BEFORE IOWR#	0	-	-	ns
$TdfIOIS16$	IOIS16# DELAY FALLING FROM ADDRESS*	-	-	10	ns
$TdrIOIS16$	IOIS16# DELAY RISING FROM ADDRESS*	-	-	0	ns
$TdfWT$	WAIT# DELAY FALLING FROM IOWR#	-	-	**	ns
$Tw(WT)$	WAIT# WIDTH TIME	-	-	**	ns
$TdrIOWR$	IOWR# HIGH FROM WAIT# HIGH	0	-	-	us

*Note : The address includes REG# and CE1# signal

** Note : There is no wait state while I/O Write operation



5.4.7 Synthesizer Timings

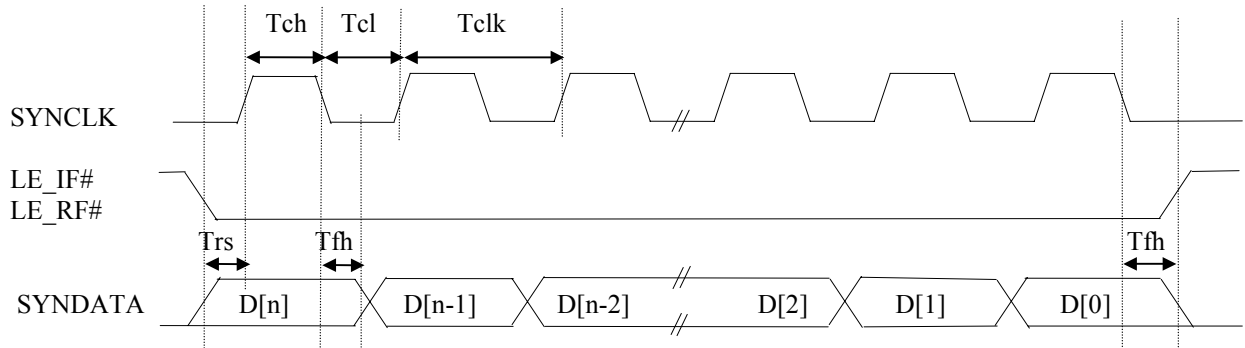

Symbol	Description	Min	Typ.	Max	Units
Tclk	Cycle time	-	90	-	ns
Tch	high time	14	-	26	ns
Tcl	low time	14	-	26	ns
Trs	Clock rising edge to data valid setup time	6	-	-	ns
Tfh	Clock falling edge to data output hold time	5	-	-	ns
Tth	Data output hold time	5	-	-	ns



5.4.8 Serial Port Timings

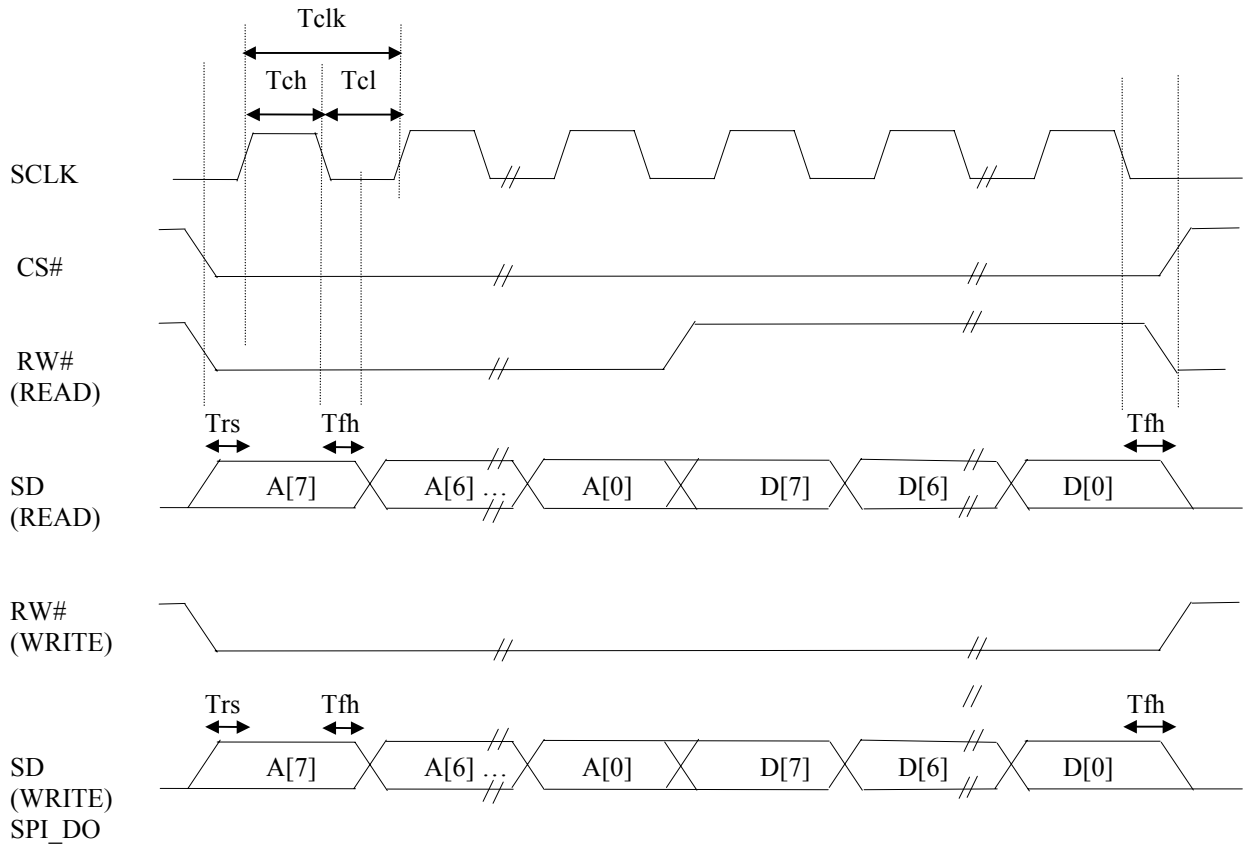



5.4.9 TX Path Waveforms

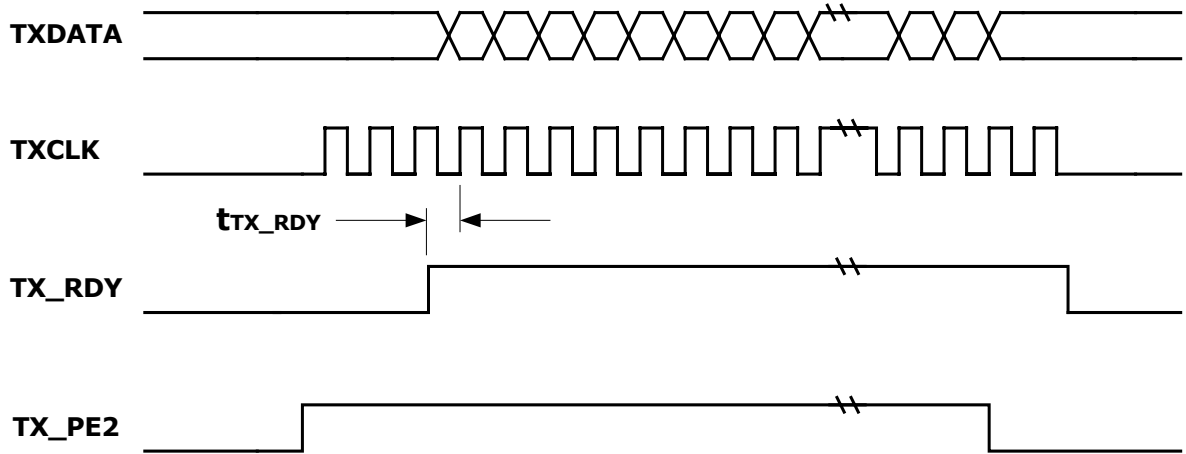

FIGURE. TX PATH



5.4.10 RX Path Waveforms

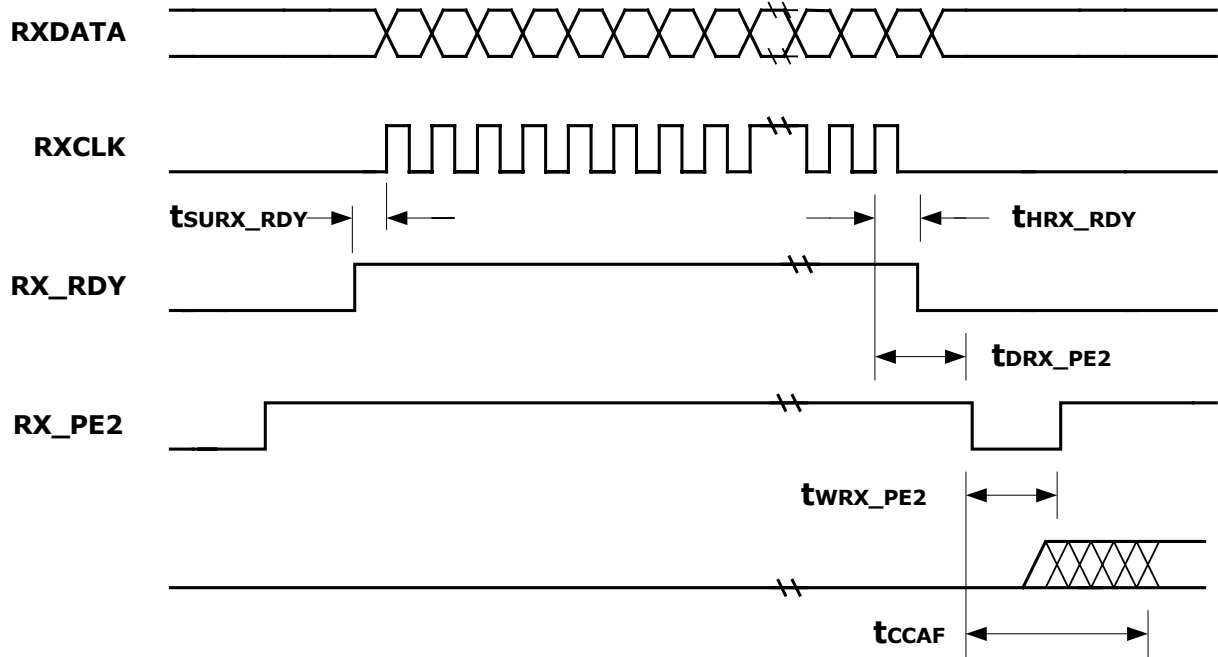
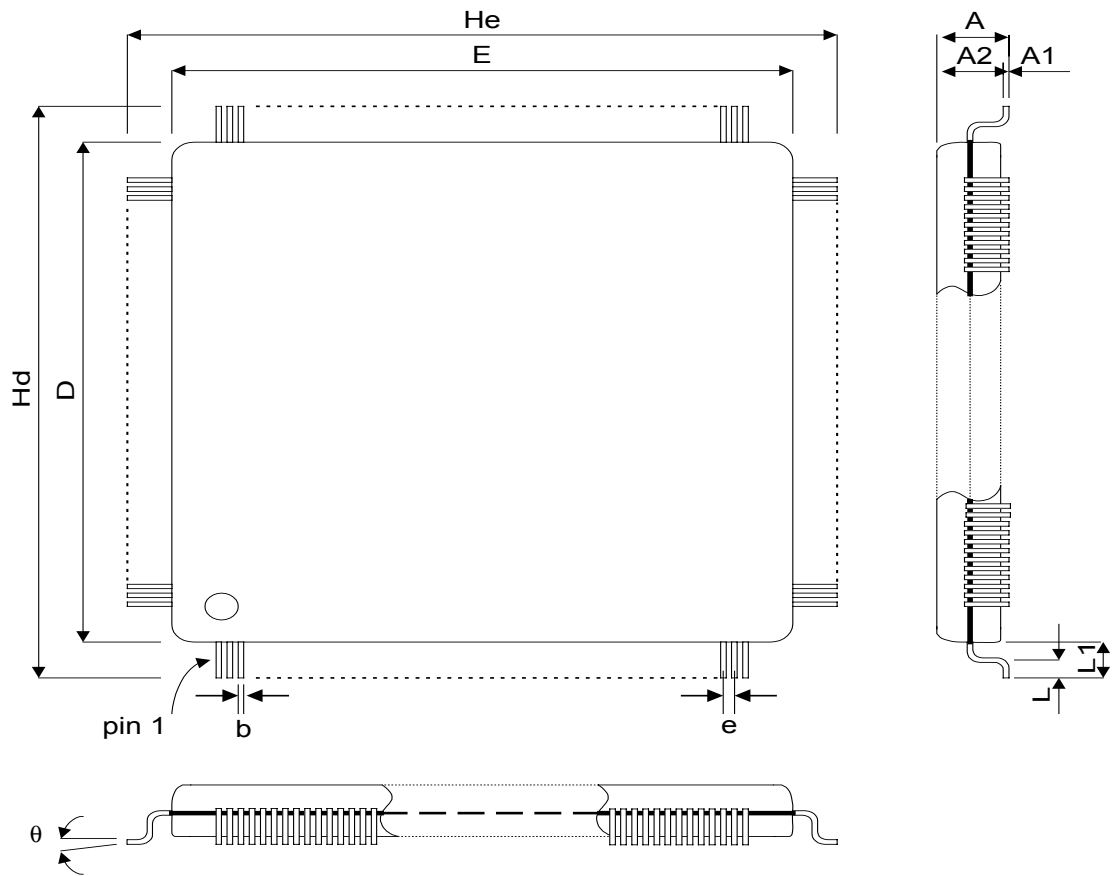

FIGURE. RX PATH



6.0 Package Information



SYMBOL	MILIMETER		
	MIN.	NOM	MAX
A1		0.1	
A2	1.3	1.4	1.5
A			1.7
b	0.155	0.16	0.26
D	13.90	14.00	14.10
E	13.90	14.00	14.10
e		0.40	
Hd	15.60	16.00	16.40
He	15.60	16.00	16.40
L	0.30	0.50	0.70
L1		1.00	
θ	0		10



Appendix A: Application Note 1

A.1 External EEPROM format

External EEPROM format:

Addr	Description
0	CIS pointer (X)
1	Physical addr[15:0]
2	Physical addr[31:16]
3	Physical addr[47:32]
4	Subsystem ID[15:0]
5	Subsystem ID[31:16]
6 ~ 10	Reserved
11 ~ X	For Driver Used
X	CIS area
X + 1	CIS area

Max addr index is 127 (93c56 – 16 bit)