

Secondary Side Post Regulator for AC/DC and DC/DC Multiple Output Converters

Description

The CS5101 is a bipolar monolithic secondary side post regulator (SSPR) which provides tight regulation of multiple output voltages in AC-DC or DC-DC converters. Leading edge pulse width modulation is used with the CS5101.

The CS5101 is designed to operate over an 8V to 45V supply voltage (V_{CC}) range and up to a 75V drive voltage (V_G).

The CS5101 features include a totem pole output with 1.5A peak output current capability, externally programmable overcurrent protection, an on chip 2% precision 5V reference, internally compensated error amplifier, externally synchronized switching frequency, and a power switch drain voltage monitor. It is available in a 14 lead plastic DIP or a 16 lead wide body SO package.

Features

- 1.5A Peak Output (Grounded Totem Pole)
- 8V to 75V Gate Drive Voltage
- 8V to 45V Supply Voltage
- 300ns Propagation Delay
- 1% Error Amplifier Reference Voltage
- Lossless Turn On and Turn Off
- Sleep Mode: $< 100\mu A$
- Overcurrent Protection with Dedicated Differential Amp
- Synchronization to External Clock
- External Power Switch Drain Voltage Monitor

Application Diagram

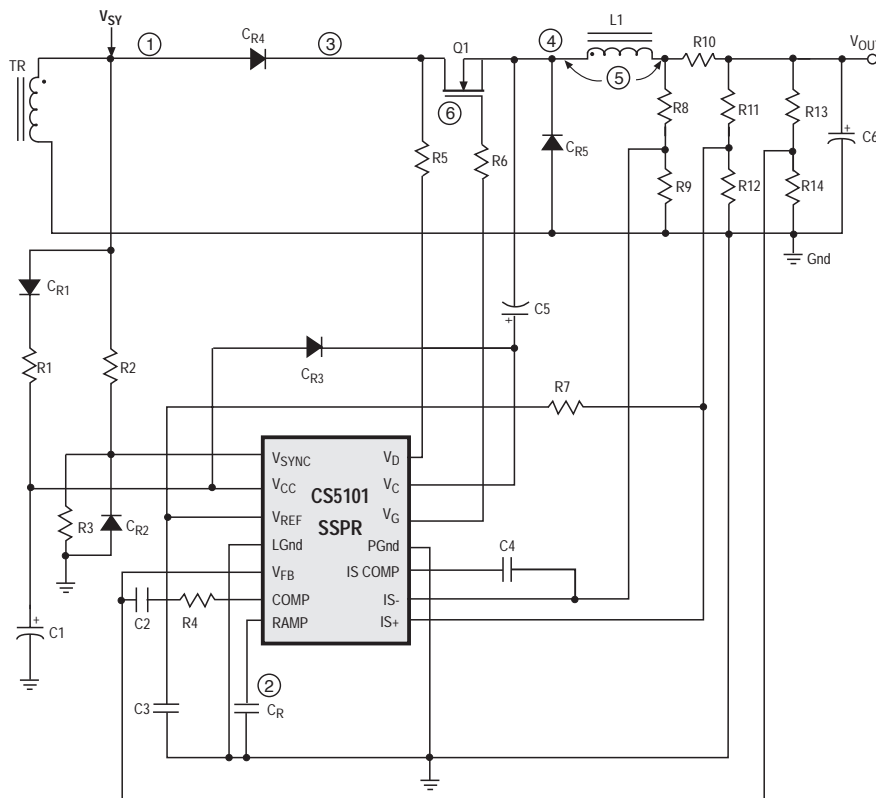

Package Options

14L PDIP

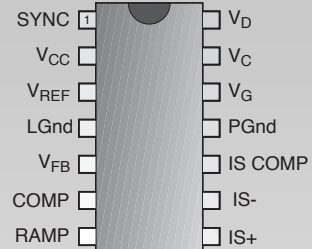

16L SO Wide

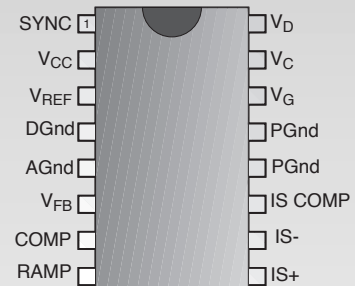

Absolute Maximum Ratings

Power Supply Voltage, V_{CC}	-0.3V to 45V
V_{SYNC} and Output Supply Voltages, V_C , V_G , V_{SYNC} , V_D	-0.3V to 75V
V_{IS+} , V_{IS-} ($V_{CC} - 4V$, up to 24V)	-0.3 to 24V
V_{REF} , V_{FB} , V_{COMP} , V_{RAMP} , V_{ISCOMP}	-0.3 to 10V
Operating Junction Temperature, T_j	-40 to 150°C
Operating Temperature Range	-40 to 85°C
Storage Temperature Range	-65 to 150°C
Output Energy (capacitive load per cycle)	5 μ J
ESD Human Body	2kV
ESD Machine Model	200V
Lead Temperature Soldering	
Wave Solder (through hole styles only)	10 sec. max, 260°C peak
Reflow (SMD styles only)	60 sec. max above 183°C, 230°C peak

Electrical Characteristics: $-40^{\circ}\text{C} \leq T_A \leq 85^{\circ}\text{C}$; $-40^{\circ}\text{C} \leq T_j \leq 150^{\circ}\text{C}$; $10\text{V} < V_{CC} < 45\text{V}$; $8\text{V} < V_C < 75\text{V}$ unless otherwise specified.

PARAMETER	TEST CONDITIONS	MIN	TYP	MAX	UNIT
■ Error Amplifier					
Input Voltage Initial Accuracy	$V_{FB} = V_{COMP}$; $V_{CC} = 15\text{V}$; $T = 25^{\circ}\text{C}$ (Note 1)	1.98	2.00	2.02	V
Input Voltage	$V_{FB} = V_{COMP}$, includes line and temp	1.94	2.00	2.06	V
Input Bias Current	$V_{FB} = 0\text{V}$; $I_{V_{FB}}$ flows out of pin			500	nA
Open Loop Gain	$1.5\text{V} < V_{COMP} < 3.0\text{V}$	60	70		dB
Unity Gain Bandwidth	$1.5\text{V} < V_{COMP} < 3.0\text{V}$; (Note 1)	0.7	1.0		MHz
Output Sink Current	$V_{COMP} = 2.0\text{V}$; $V_{FB} = 2.2\text{V}$	2	8		mA
Output Source Current	$V_{COMP} = 2.0\text{V}$; $V_{FB} = 1.8\text{V}$	2	6		mA
V_{COMP} High	$V_{FB} = 1.8\text{V}$	3.3	3.5	3.7	V
V_{COMP} Low	$V_{FB} = 2.2\text{V}$	0.85	1.0	1.15	V
PSRR	$10\text{V} < V_{CC} < 45\text{V}$; $V_{FB} = V_{COMP}$ (Note 1)	60	70		dB
■ Voltage Reference					
Output Voltage Initial Accuracy	$V_{CC} = 15\text{V}$; $T = 25^{\circ}\text{C}$ (Note 1)	4.9	5.0	5.1	V
Output Voltage	$0\text{A} < I_{REF} < 8\text{mA}$	4.8	5.0	5.2	V
Line Regulation	$10\text{V} < V_{CC} < 45\text{V}$; $I_{REF} = 0\text{A}$		10	60	mV
Load Regulation	$0\text{A} < I_{REF} < 8\text{mA}$		20	60	mV
Current Limit	$V_{REF} = 4.8\text{V}$	10	50		mA
V_{REF_OK} FAULT V	$V_{SYNC} = 5\text{V}$; $V_{REF} = V_{LOAD}$	4.10	4.40	4.60	V
V_{REF_OK} V	$V_{SYNC} = 5\text{V}$; $V_{REF} = V_{LOAD}$	4.30	4.50	4.80	V
V_{REF_OK} Hysteresis		40	100	250	mV
■ Current Sense Amplifier					
IS COMP High V	$IS^+ = 5\text{V}$; $IS^- = IS\ COMP$	4.7	5.0	5.3	V
IS COMP Low V	$IS^+ = 0\text{V}$; $IS^- = IS\ COMP$	0.5	1.0	1.3	V
Source Current	$IS^+ = 5\text{V}$; $IS^- = 0\text{V}$	2.0	10		mA
Sink Current	$IS^- = 5\text{V}$; $IS^+ = 0\text{V}$	10	20		mA
Open Loop Gain	$1.5\text{V} \leq V_{COMP} \leq 4.5\text{V}$; $R_L = 4\text{k}\Omega$	60	80		dB
CMRR	(Note 1)	60	80		dB
PSRR	$10\text{V} < V_{CC} < 45\text{V}$, (Note 1)	60	80		dB
Unity Gain Bandwidth	$1.5\text{V} \leq V_{COMP} \leq 4.5\text{V}$; $R_L = 4\text{k}\Omega$ (Note 1)	0.5	0.8		MHz

Electrical Characteristics: continued

CS5101

PARAMETER	TEST CONDITIONS	MIN	TYP	MAX	UNIT
■ Current Sense Amplifier: continued					
Input Offset Voltage	$V_{IS^+} = 2.5V; V_{IS^-} = V_{ISCOMP}$	-8	0	8	mV
Input Bias Currents	$V_{IS^+} = V_{IS^-} = 0V; I_{IS}$ flows out of pins		20	250	nA
Input Offset Current (IS^+ , IS^-)		-250	0	250	nA
Input Signal Voltage Range	(Note 1)	-0.3		$V_{CC}-4.0$	V
■ RAMP/SYNC Generator					
Ramp Source Current Initial Accuracy	$V_{SYNC} = 5V; V_{RAMP} = 2.5V; T = 25^{\circ}C$ (Note 1)	0.18	0.20	0.22	mA
Ramp Source Current	$V_{SYNC} = 5V; V_{RAMP} = 2.5V$	0.16	0.20	0.24	mA
Ramp Sink Current	$V_{SYNC} = 0V; V_{RAMP} = 2.5V$	1.0	4.0		mA
RAMP Peak Voltage	$V_{SYNC} = 5V$	3.3	3.5	3.7	V
RAMP Valley Voltage	$V_{SYNC} = 0V$	1.4	1.5	1.6	V
RAMP Dynamic Range	$V_{RAMPDR} = V_{RAMPpk} - V_{RAMPVY}$	1.7	2.0	2.3	V
RAMP Sleep Threshold Voltage	$V_{RAMP} @ V_{REF} < 2.0V$	0.3	0.6	1.0	V
SYNC Threshold	$V_{SYNC} @ V_{RAMP} > 2.5V$	2.3	2.5	2.7	V
SYNC Input Bias Current	$V_{SYNC} = 0V; I_{SYNC}$ flows out of pin		1	20	μA
■ Output Stage					
V_G , High	$V_{SYNC} = 5V; I_{VG} = 200mA; V_C - V_G$		1.6	2.5	V
V_G , Low	$V_{SYNC} = 0V; I_{VG} = 200mA$		0.9	1.5	V
V_G Rise Time	Switch V_{SYNC} High; $C_G = 1nF$; $V_{CC} = 15V$; measure 2V to 8V		30	75	ns
V_G Fall Time	Switch V_{SYNC} Low; $C_G = 1nF$; $V_{CC} = 15V$; measure 8V to 2V		40	100	ns
V_G Resistance to Gnd	Remove supplies; $V_G = 10V$		50	100	k Ω
V_D Resistance to Gnd	Remove supplies; $V_D = 10V$	500	1500		Ω
■ General					
I_{CC} , Operating	$V_{SYNC} = 5V$		12	18	mA
I_{CC} in UVL	$V_{CC} = 6V$		300	500	μA
I_{CC} in Sleep Mode High	$V_{RAMP} = 0V; V_{CC} = 45V$		80	200	μA
I_{CC} In Sleep Mode Low	$V_{RAMP} = 0V; V_{CC} = 10V$		20	50	μA
I_C , Operating High	$V_{SYNC} = 5V; V_{FB} = V_{IS^-} = 0V$; $V_C = 75V$		4	8	mA
I_C , Operating Low	$V_{SYNC} = 5V; V_{FB} = V_{IS^-} = 0V; V_C = 8V$		3	6	mA
UVLO Start Voltage		7.4	8.0	9.2	V
UVLO Stop Voltage		6.4	7.0	8.3	V
UVLO Hysteresis		0.8	1.0	1.2	V
Leading Edge, t_{DELAY}	$V_{SYNC} = 2.5V$ to $V_G = 8V$		280		ns
Trailing Edge, t_{DELAY}	$V_{SYNC} = 2.5V$ to $V_G = 2V$		750		ns

Note 1: Guaranteed by design. Not 100% tested in production.

Package Pin Description

CS5101

PACKAGE PIN #		PIN SYMBOL	FUNCTION
14L PDIP	16L SO Wide		
1	1	SYNC	Synchronization input.
2	2	V _{CC}	Logic supply (10V to 45V).
3	3	V _{REF}	5.0V voltage reference.
4		LGnd	Logic level ground (Analog and digital ground tied).
5	6	V _{FB}	Error amplifier inverting input.
6	7	COMP	Error amplifier output and compensation.
7	8	RAMP	RAMP programmable with the external capacitor.
8	9	IS+	Current sense amplifier non-inverting input.
9	10	IS-	Current sense amplifier inverting input.
10	11	IS COMP	Current sense amplifier compensation and output.
11	12, 13	PGnd	Power ground.
12	14	V _G	External power switch gate drive.
13	15	V _C	Output power stage supply voltage (8V to 75V).
14	16	V _D	External FET DRAIN Voltage Monitor.
	5	AGnd	Analog Ground.
	4	DGnd	Digital Ground.

Circuit Description

Block Diagram

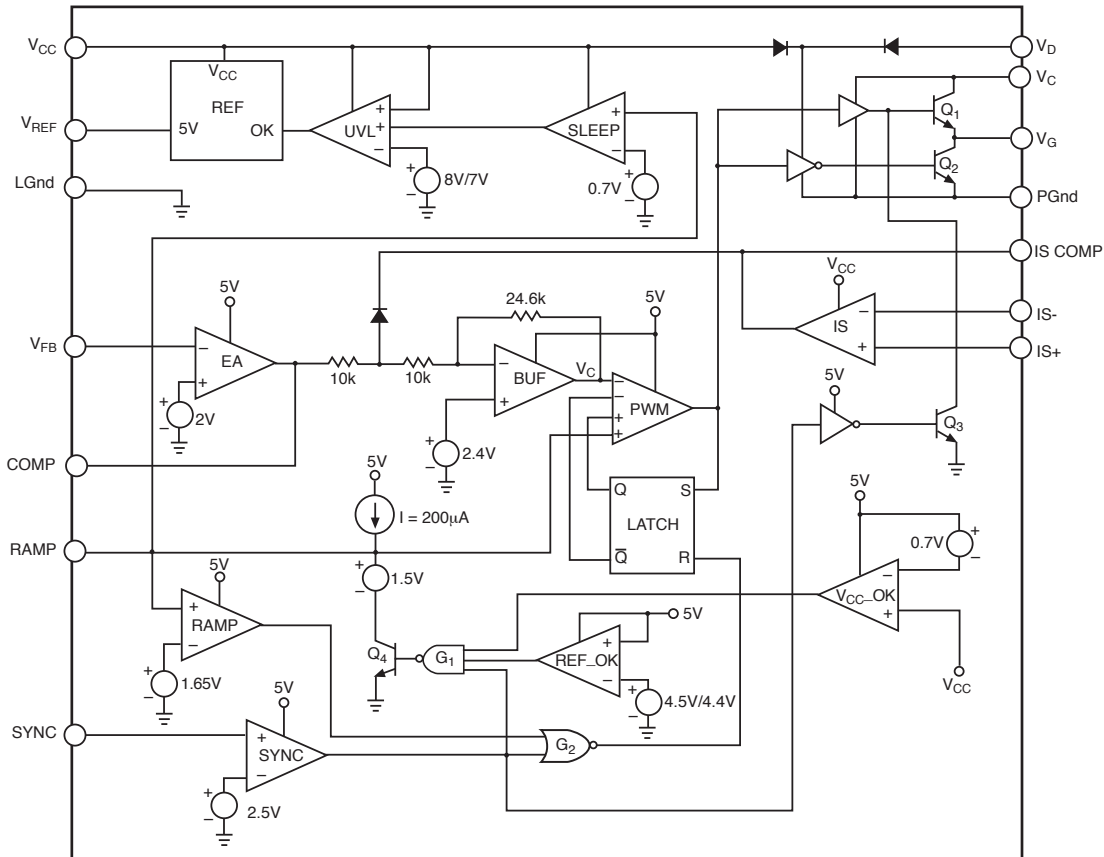

Theory of Operation

The CS5101 is designed to regulate voltages in multiple output power supplies. Functionally, it is similar to a magnetic amplifier, operating as a switch with a delayed turn-on. It can be used with both single ended and dual ended topologies.

The V_{FB} voltage is monitored by the error amplifier EA. It is compared to an internal reference voltage and the amplified differential signal is fed through an inverting amplifier into the buffer, BUF. The buffered signal is compared at the PWM comparator with the ramp voltage generated by capacitor C_R . When the ramp voltage V_{R} exceeds the control voltage V_C , the output of the PWM comparator goes high, latching its state through the LATCH, the output stage transistor Q_1 turns on, and the external power switch, usually an N-FET, turns on.

SYNC Function

The SYNC circuit is activated at time t_1 (Figure 1) when the voltage at the SYNC pin exceeds the threshold level (2.5V) of the SYNC comparator. The external ramp capacitor C_R is allowed to charge through the internal current source I (200 μ A). At time t_2 , the ramp voltage intersects with the control voltage V_C and the output of the PWM comparator goes high, turning on the output stage and the external power switch. At the same time, the PWM comparator is latched by the RS latch, LATCH.

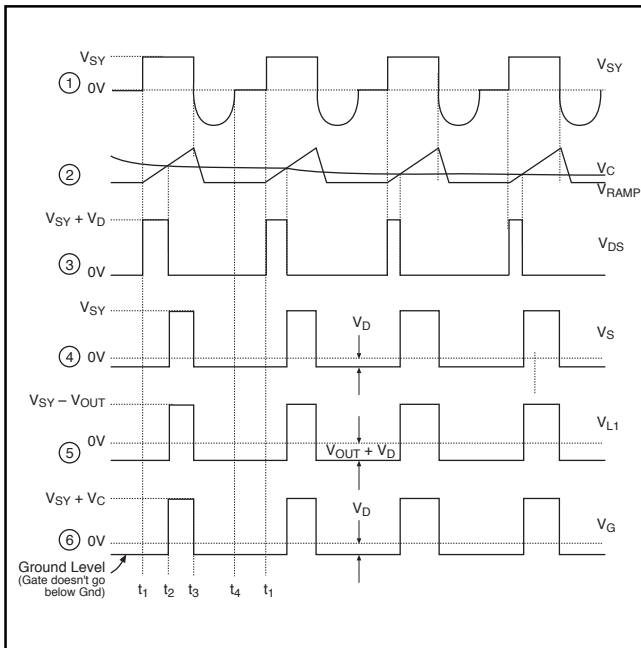

Figure 1. Waveforms for CS5101. The number to the left of each curve refers to a node on the Application Diagram.

The logic state of the LATCH can be changed only when both the voltage level of the trailing edge of the power pulse at the SYNC pin is less than the threshold voltage of the SYNC comparator (2.5V) and the RAMP voltage is less than the threshold voltage of the RAMP comparator (1.65V). On the negative going transition of the secondary side pulse V_{SY} , gate G_2 output goes high, resetting the latch at time t_3 . Capacitor C_R is discharged through transistor Q_4 . C_R 's output goes low disabling the output stage, and the external power switch (an N-FET) is turned off.

RAMP Function

The value of the ramp capacitor C_R is based on the switching frequency of the regulator and the maximum duty cycle of the secondary pulse V_{SY} . If the RAMP pin is pulled externally to 0.3V or below, the SSPR is disabled. Current drawn by the IC is reduced to less than 100 μ A, and the IC is in SLEEP mode.

FAULT Function

The voltage at the V_{CC} pin is monitored by the undervoltage lockout comparator with hysteresis. When V_{CC} falls below the UVL threshold, the 5V reference and all the circuitry running off of it is disabled. Under this condition the supply current is reduced to less than 500 μ A.

The V_{CC} supply voltage is further monitored by the V_{CC_OK} comparator. When V_{CC} is reduced below $V_{REF} - 0.7V$, a fault signal is sent to gate G_1 . This fault signal, which determines if V_{CC} is absent, works in conjunction with the ramp signal to disable the output, but only after the current cycle has finished and the RS latch is reset. Therefore this fault will not cause the output to turn off during the middle of an on pulse, but rather will utilize lossless turn-off. This feature protects the FET from over-voltage stress. This is accomplished through gate G_1 by driving transistor Q_4 on.

An additional fault signal is derived from the REF_OK comparator. V_{REF} is monitored so to disable the output through gate G_1 when the V_{REF} voltage falls below the OK threshold. As in the V_{CC_OK} fault, the REF_OK fault disables the output after the current cycle has been completed. The fault logic will operate normally only when V_{REF} voltage is within the specification limits of REF_OK.

DRAIN Function

The drain pin, V_D monitors the voltage on the drain of the power switch and derives energy from it to keep the output stage in an off state when V_C or V_{CC} is below the minimum specified voltage.

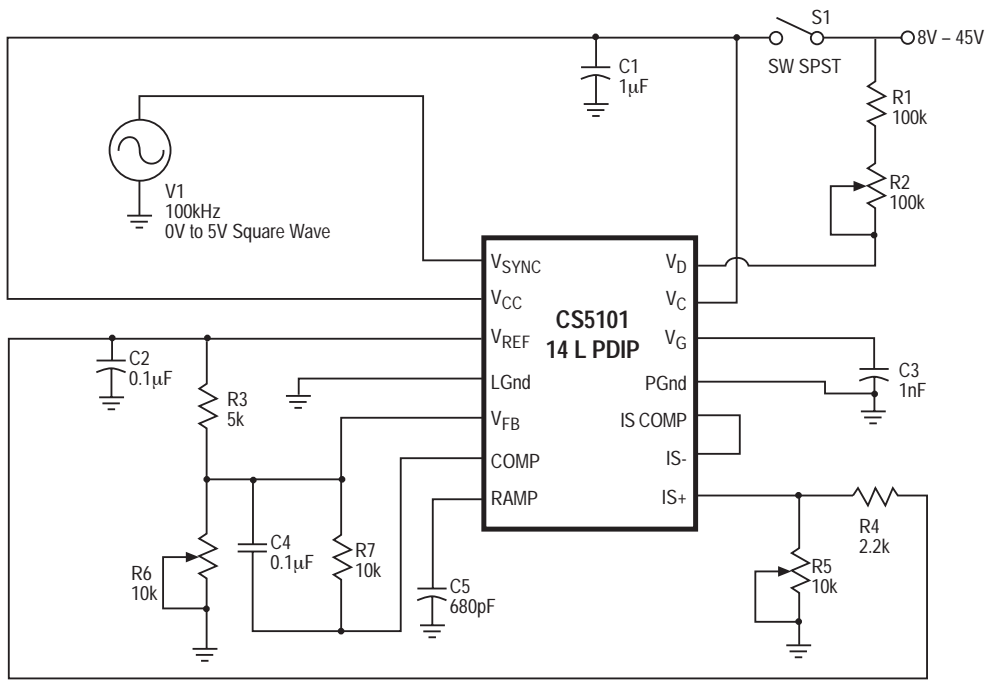

CS5101 bench test

Package Specification

CS5101

PACKAGE DIMENSIONS IN mm (INCHES)

PACKAGE THERMAL DATA

Lead Count	D			
	Metric		English	
	Max	Min	Max	Min
14L PDIP	19.69	18.67	.775	.735
16L SO Wide	10.50	10.10	.413	.398

Thermal Data		16L SOIC	14L PDIP	
$R_{\theta JC}$	typ	23	48	$^{\circ}C/W$
$R_{\theta JA}$	typ	105	85	$^{\circ}C/W$

Plastic DIP (N); 300 mil wide

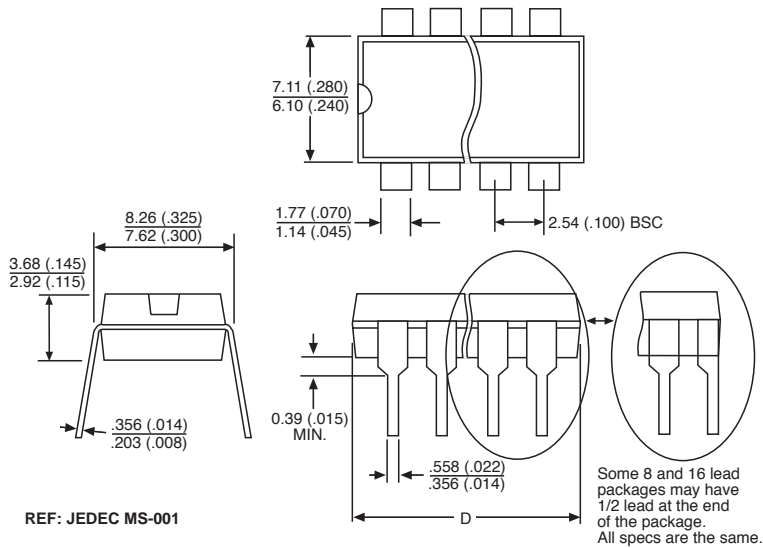

Surface Mount Wide Body (DW); 300 mil wide

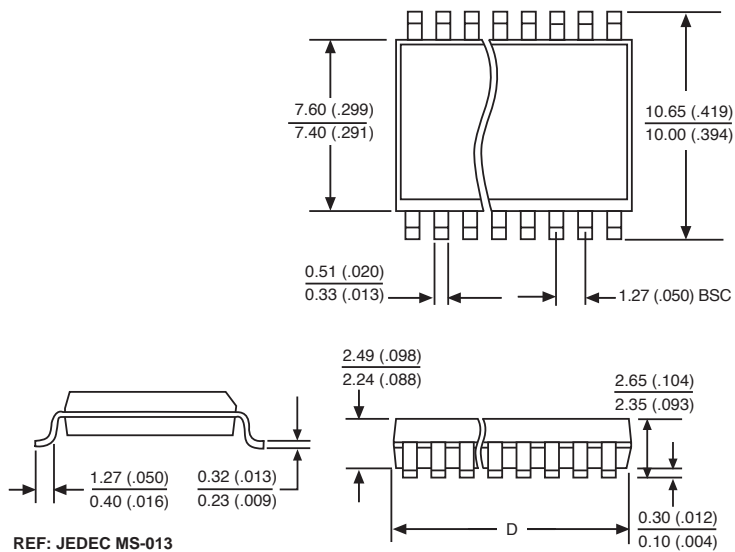

Ordering Information

Part Number	Description
CS5101EN14	14L PDIP
CS5101EDW16	16L SO Wide
CS5101EDWR16	16L SO Wide (tape & reel)

Cherry Semiconductor Corporation reserves the right to make changes to the specifications without notice. Please contact Cherry Semiconductor Corporation for the latest available information.

PATENTS PENDING