



Leaded Oscillator, TCXO, TCVCXO
Metal Package, Full Size DIP



I121/I122/I321/I322 Series

Product Features:

Available in Both Clipped Sinewave and HCMOS Output Levels
Compatible with Leadfree Processing

Applications:

Base Station
IP
WiMax / WLAN
General Purpose

Frequency I121/I321 I122/I322	9.600 Mhz to 40 Mhz 1.000 Mhz to 40 Mhz
Output Level Clipped Sinewave HCMOS	1.0 V p-p Min. '0'=0.1 VCC Max., '1'=0.9Vcc Min.
Output Load Clipped Sinewave HCMOS	20K Ohms / 10 pF 15pF
Duty Cycle (HCMOS)	50% ±10%
Rise / Fall Time (HCMOS)	10 nS Max.
Frequency Stability	See Frequency Stability Table
Frequency Tolerance @ 25° C	Included in Stability Tolerance
Aging	± 1 ppm / Year Max.
Supply Voltage	See Supply Voltage Table , tolerance ± 5%
Current	3.0 mA Max. (Clipped Sinewave) 20.0 mA Max. (HCMOS)
Voltage Control (I321/ I322)	1.65 VDC ± 1.5 VDC, ± 5.0 ppm Min. for Vcc = 3.3 VDC 2.5 VDC ± 2.0 VDC, ± 5.0 ppm Min. for Vcc = 5.0 VDC
Slope	Positive
Operating	See Operating Temperature Table
Storage	-40° C to +85° C

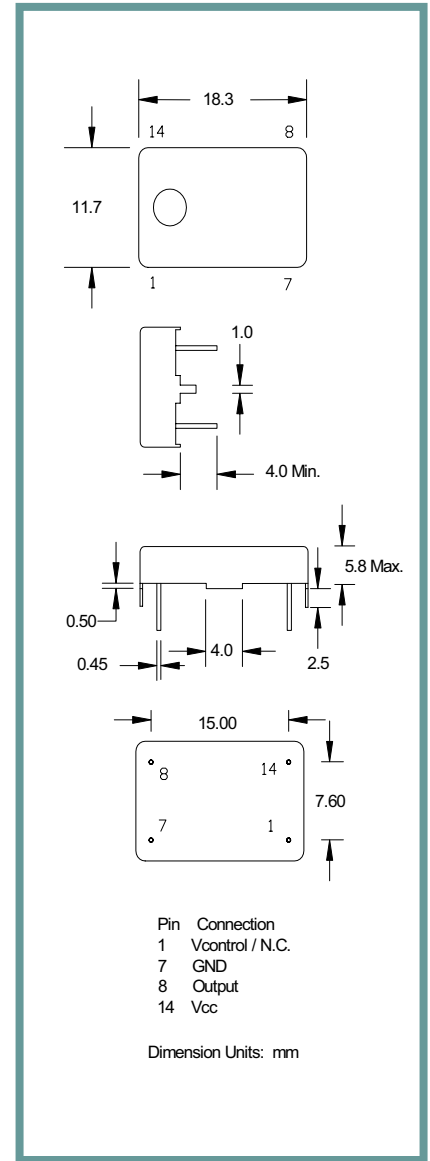

Part Number Guide		Sample Part Number: I121-1Q3-20.000 Mhz		
Package	Operating Temperature	Frequency Stability vs Temperature	Supply Voltage	Frequency
I121 (Clipped Sinewave TCXO)	7 = 0° C to +50° C	**O = ±1.5 ppm	3 = 3.3 V	- 20.000 MHz
I122 (HCMOS TCXO)	1 = 0° C to +70° C	**P = ±2.0 ppm	5 = 5.0 V	
I321 (Clipped Sinewave TCVCXO)	3 = -20° C to +70° C	Q = ±2.5 ppm		
I322 (HCMOS TCVCXO)	2 = -40° C to +85° C	R = ±3.0 ppm		
		J = ±5.0 ppm		

NOTE: A 0.01 µF bypass capacitor is recommended between Vcc (pin 4) and GND (pin 2) to minimize power supply noise.
** Not available for all temperature ranges.



Leaded Oscillator, TCXO, TCVCXO
Metal Package, Full Size DIP



1121/1122/1321/1322 Series

Pb Free Solder Reflow Profile:

Typical Application:

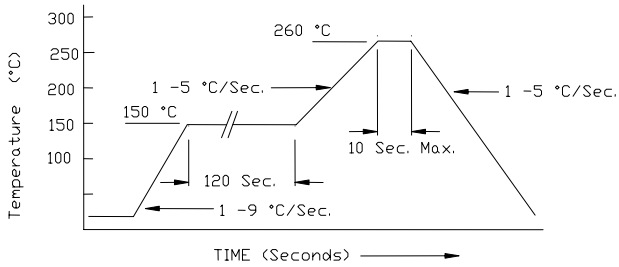

*Units are backward compatible with 240C reflow processes

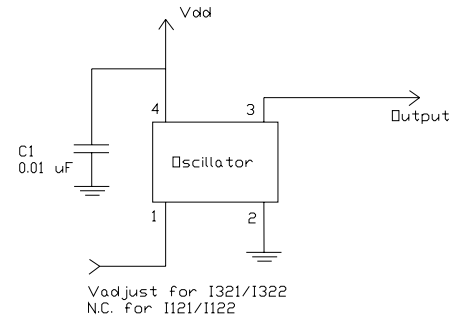

Package Information:

MSL = 2a
Termination = e1 (Sn / Cu / Ag over Ni over Kovar base metal).

Environmental Specifications

Thermal Shock	MIL-STD-883, Method 1011, Condition A
Moisture Resistance	MIL-STD-883, Method 1004
Mechanical Shock	MIL-STD-883, Method 2002, Condition B
Mechanical Vibration	MIL-STD-883, Method 2007, Condition A
Resistance to Soldering Heat	J-STD-020C, Table 5-2 Pb-free devices (except 2 cycles max)
Hazardous Substance	Pb-Free / RoHS / Green Compliant
Solderability	JESD22-B102-D Method 2 (Preconditioning E)
Terminal Strength	MIL-STD-883, Method 2004, Test Condition D
Gross Leak	MIL-STD-883, Method 1014, Condition C
Fine Leak	MIL-STD-883, Method 1014, Condition A2, R1=2x10 ⁻⁸ atm cc/s
Solvent Resistance	MIL-STD-202, Method 215

Marking

Line 1: ILSI and Date Code
Line 2: IXXX-XXX (Part Number detail = IXXX-XXX-Freq.)
Line 3: Frequency