

SPECIFICATION FOR APPROVAL

REF :

PAGE: 1

PROD. NAME	MULTILAYER CHIP INDUCTOR	ABC'S DWG NO.	MH1608□□□□2□-□□□
		ABC'S ITEM NO.	

I . CONFIGURATION & DIMENSIONS :

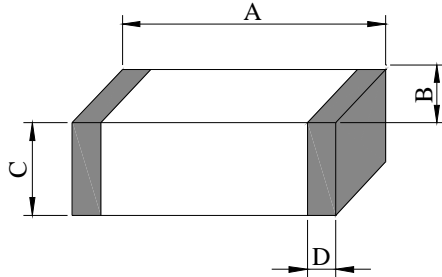

- A : 1.60±0.15 m/m
- B : 0.80±0.15 m/m
- C : 0.80±0.15 m/m
- D : 0.40±0.20 m/m

II . SCHEMATIC DIAGRAM :

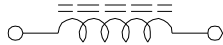

III . FEATURES :

- a . Monolithic structure ensuring high performance and reliability.
- b . High frequency applications up to 6GHz.
- c . Terminal : Ag/Cu/Ni/Sn
- d . Remark : Products comply with RoHS' requirements

IV . APPLICATIONS :

- a . RF modules for telecommunication systems including GSM, PCS, DECT, WLAN, Bluetooth, etc.

V . GENERAL SPECIFICATION :

- a . Storage Conditions :
 Electrical Performance temp : -55°C ~ +125°C
 Terminal Solderability & Packages Material temp :
 -10°C ~ +40°C and RH 70% max.
- b . Operating temp. : -55°C ---- +125°C
- c . Solderability : Preheat : 150±25°C for 60 seconds
 Solder : Sn96.5 / Ag3 / Cu0.5
 or equivalent
 Solder temp. : 260±5°C
 Flux : Rosin
 Dip time : 4±1 seconds

Peak Temp : 260°C max.
 Max time above 230°C : 50sec max.
 Max time above 200°C : 70sec max.

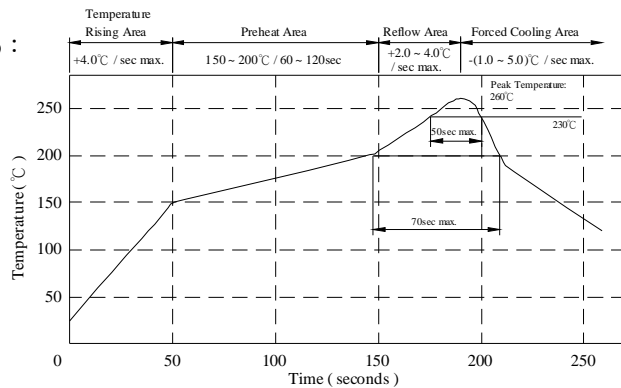

SPECIFICATION FOR APPROVAL

REF :

PAGE: 2

PROD. NAME	MULTILAYER CHIP INDUCTOR	ABC'S DWG NO.	MH1608□□□□2□-□□□
		ABC'S ITEM NO.	

VI . ELECTRICAL CHARACTERISITCS :

DWG No.	Inductance (nH)	Q min.	L / Q Test Freq. (MHz)	SRF (GHz) min.	RDC (Ω) max.	IDC (mA) max.
MH16081N0D2□-□□□	1.0 ± 0.3	8	100	10.0	0.05	300
MH16081N2D2□-□□□	1.2 ± 0.3	8	100	10.0	0.05	300
MH16081N5D2□-□□□	1.5 ± 0.3	8	100	6.0	0.10	300
MH16081N8D2□-□□□	1.8 ± 0.3	8	100	6.0	0.10	300
MH16082N2D2□-□□□	2.2 ± 0.3	8	100	6.0	0.10	300
MH16082N7D2□-□□□	2.7 ± 0.3	10	100	6.0	0.10	300
MH16083N3D2□-□□□	3.3 ± 0.3	10	100	6.0	0.12	300
MH16083N9D2□-□□□	3.9 ± 0.3	10	100	6.0	0.14	300
MH16084N7D2□-□□□	4.7 ± 0.3	10	100	4.0	0.16	300
MH16085N6D2□-□□□	5.6 ± 0.3	10	100	4.0	0.18	300
MH16086N8J2□-□□□	6.8 ± 5%	10	100	4.0	0.22	300
MH16088N2J2□-□□□	8.2 ± 5%	10	100	3.5	0.24	300
MH160810NJ2□-□□□	10.0 ± 5%	12	100	3.4	0.26	300
MH160812NJ2□-□□□	12.0 ± 5%	12	100	2.6	0.28	300
MH160815NJ2□-□□□	15.0 ± 5%	12	100	2.3	0.32	300
MH160818NJ2□-□□□	18.0 ± 5%	12	100	2.0	0.35	300
MH160822NJ2□-□□□	22.0 ± 5%	12	100	1.6	0.40	300
MH160827NJ2□-□□□	27.0 ± 5%	12	100	1.4	0.45	300
MH160833NJ2□-□□□	33.0 ± 5%	12	100	1.2	0.55	300
MH160839NJ2□-□□□	39.0 ± 5%	12	100	1.1	0.60	300
MH160847NJ2□-□□□	47.0 ± 5%	12	100	0.9	0.70	300
MH160856NJ2□-□□□	56.0 ± 5%	12	100	0.9	0.75	300
MH160868NJ2□-□□□	68.0 ± 5%	12	100	0.7	0.85	300
MH160882NJ2□-□□□	82.0 ± 5%	12	100	0.6	0.95	300
MH1608R10J2□-□□□	100.0 ± 5%	12	100	0.6	1.00	300

1). □ : Packaging Information... [A] : Bulk [B] : Taping Reel

2). "-□□□" : Reference code

SPECIFICATION FOR APPROVAL

REF :

PAGE: 3

PROD. NAME	MULTILAYER CHIP INDUCTOR	ABC'S DWG NO.	MH1608□□□□2□-□□□
		ABC'S ITEM NO.	

VII . L / Q VS. FREQ. CURVE :

INDUCTANCE VS FREQUENCY CHARACTERISTICS

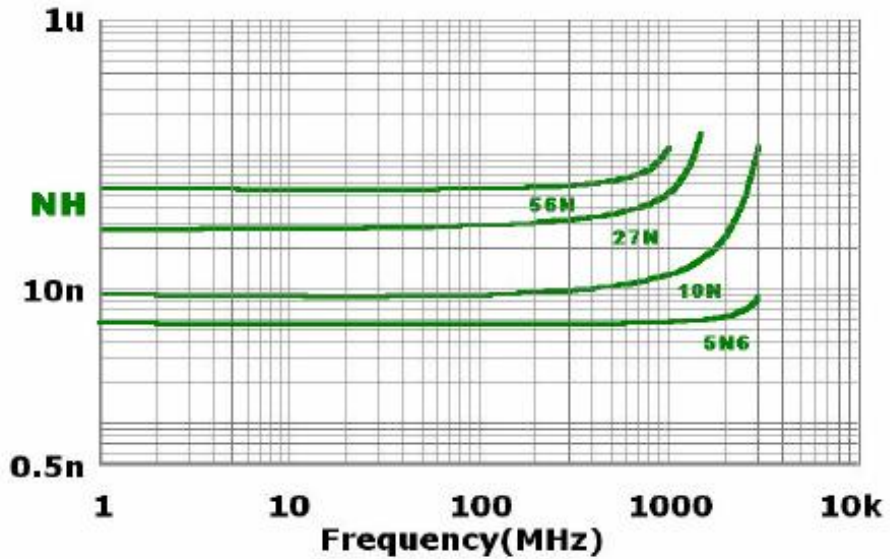

Q VS FREQUENCY CHARACTERISTICS

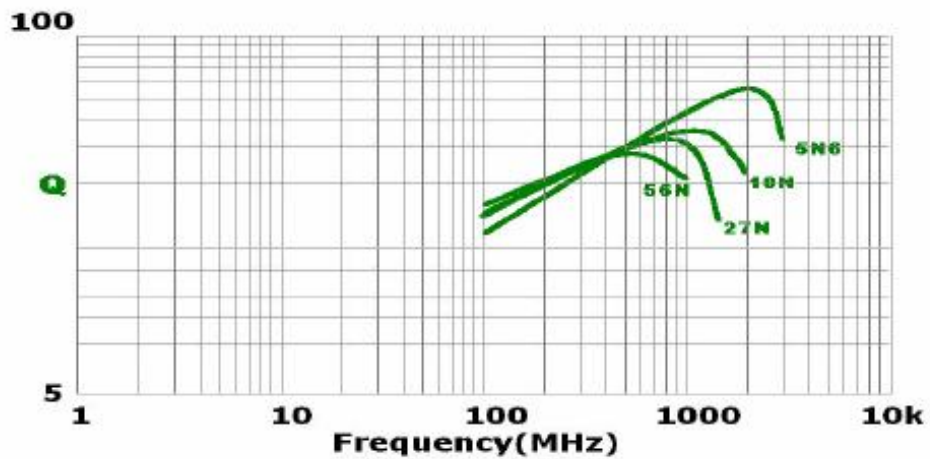

SPECIFICATION FOR APPROVAL

REF :

PAGE: 4

PROD. NAME MULTILAYER CHIP INDUCTOR	ABC'S DWG NO. MH1608□□□□2□-□□□
	ABC'S ITEM NO.

VIII . PACKAGING INFORMATION :

(1) Configuration

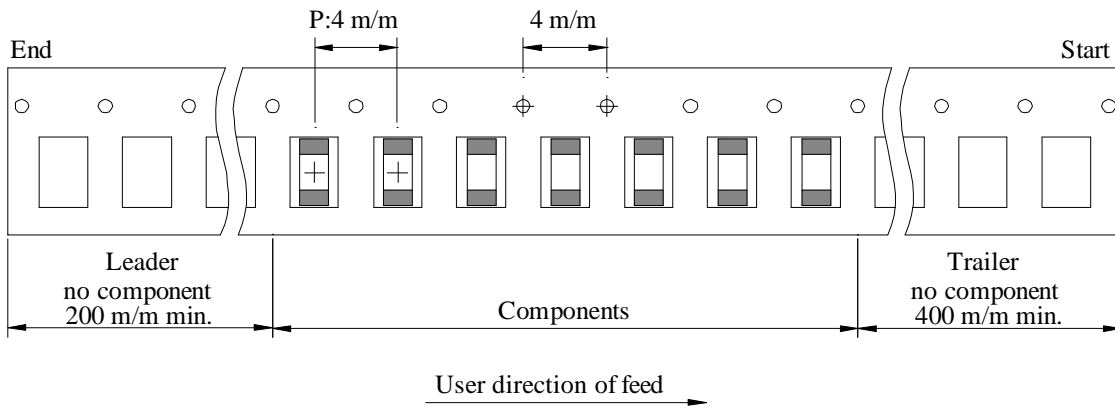
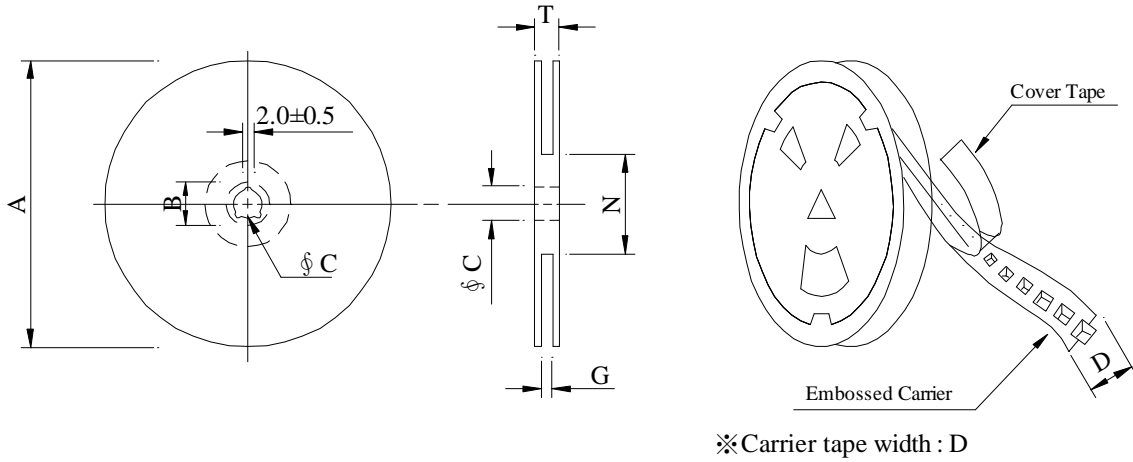

(2) Dimensions

Unit:m/m

Style	A	B	C	D	G	N	T
07 - 08	178	21±0.8	13	8	10 ⁺⁰	50 ⁻⁰	12.5

(3) Q'TY & G.W. Per package

Series	Inner : Reel			Outer : Carton		
	Q'TY (pcs)	G.W. (gw)	Style	Q'TY (pcs)	G.W. (Kg)	Size (cm)
MH1608	4,000	90	07 - 08	200,000	7.0	41 x 39 x 22

AR-001A

SPECIFICATION FOR APPROVAL

REF :

PAGE: 5

PROD. NAME	MULTILAYER CHIP INDUCTOR	ABC'S DWG NO.	MH1608□□□□2□-□□□
		ABC'S ITEM NO.	

(4) TYPE DIMENSIONS

Fig 1.

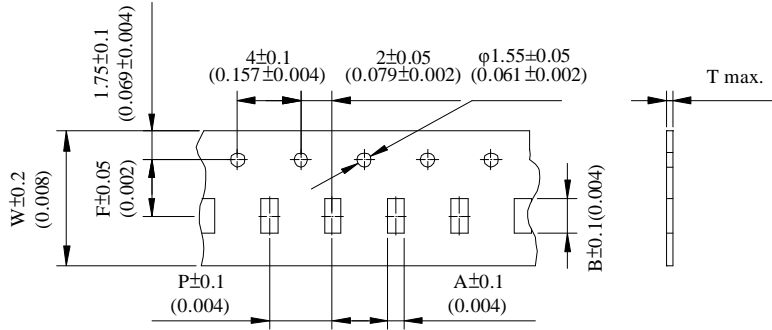

Unit:m/m

Type	A	B	F	P	T	W	Fig
MH1608	1.05	1.85	3.50	4.0	1.10	8.0	1

SPECIFICATION FOR APPROVAL

REF :

PAGE: 6

PROD. NAME	MULTILAYER CHIP INDUCTOR	ABC'S DWG NO.	MH1608□□□□2□-□□□
		ABC'S ITEM NO.	

IX . DWGING NUMBER EXPRESSION :

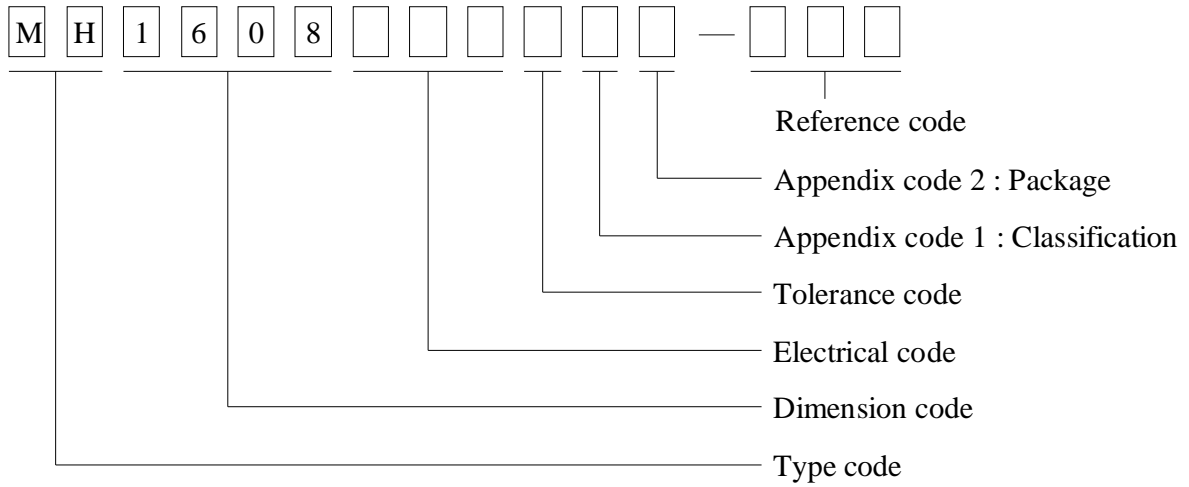

Appendix code 1 : Product Classification

- L : Lead Free Standard products comply with RoHS' requirements
- 1 ~ 9 : Lead Free Special products comply with RoHS' requirements

Appendix code 2 : Package Information

Code	Inner package	Inner package Q'TY	Remark
A	T.B.D.	T.B.D.	
B	T / R (Reel package)	4000 pcs	