

**FEATURES**

- 12 dB Gain
- Balanced Design
- High Linearity
- Low Noise Figure
- Single Supply
- Wide Bandwidth

**APPLICATIONS**

- Driver Amplifier
- CATV - Distribution / Drop Amplifiers
- Settop Boxes
- Home Gateway



**Ordering Information**  
**ABA3100S3**  
**16 Pin SOIC Package**

**Description**

The ABA3100 is a monolithic IC intended for use in applications requiring high linearity such as: Cellular Telephone Base Station Driver Amplifiers, CATV Fiber Receiver/Distribution Amplifiers, CATV Drop Amplifiers, CATV Settop Boxes and Home Gateway. Supplied in a surface mount, 16 lead-SOIC package, it is well suited for use in amplifiers where small size, reduced component count, and high reliability are important.

**ABA3100 Block Diagram**

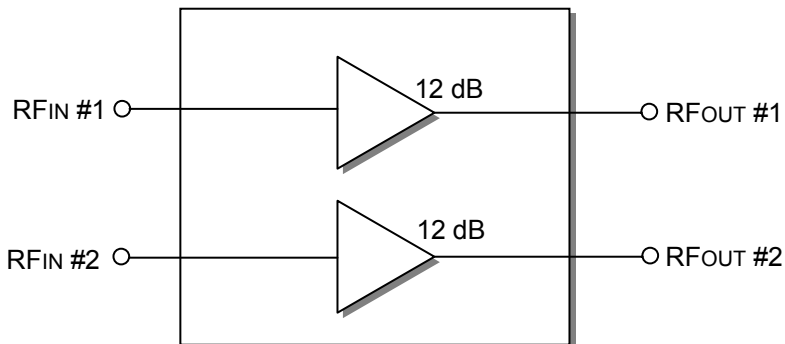

## Absolute Maximum Ratings

PARAMETER	MIN	MAX	UNITS
$V_{DD}/V_{RFOUT}$	0	12	$V_{DC}$
$V_{RFIN}$		0	$V_{DC}$
$RF_{IN}$		+ 10	dBm
Storage Temperature	- 65	+150	°C
Soldering Temperature		260	°C
Soldering Time		5.0	Sec.
Thermal Resistance		10	°C/W

## Electrical Specifications

( $T_A = +25\text{ }^\circ\text{C}$ ,  $RF = 50$  to  $1000$  MHz, Test System =  $75\Omega$ ,  $V_{DD} = +5V @ 150$  mA Typ )

PARAMETER	MIN	TYP	MAX	UNITS
Gain	11	12	14	dB
Noise Figure 50 MHz - 350 MHz		2.5	3.0	dB
350 MHz - 550 MHz		2.7	3.5	dB
550 MHz - 860 MHz		3.2	4.0	dB
Input/Output Return Loss	10	18		
$CSO^1$		-72	-70	dBc
$CTB^1$		-75	-73	dBc
2nd Order Output Intercept Point (OIP2) <sup>2</sup>		60		dBm
3rd Order Output Intercept Point (OIP3) <sup>2</sup>		35		dBm
$I_{DD}$ ( $V_{DD} = 5.0V$ )	120	150	170	mA

- 132 channels, + 25 dBmV per channel, (measured at the output) 6 MHz channel spacing.
- Two tones, @ 397 MHz and 403 MHz, +4dBm per tone.

## Operating Ranges

PARAMETER	MIN	TYP	MAX	UNITS
$V_{DD}$	4.5	5	9	Volts
Case Temperature	-40	-	85	°C

Test circuit for ABA3100 (5V, 150 mA typical bias)

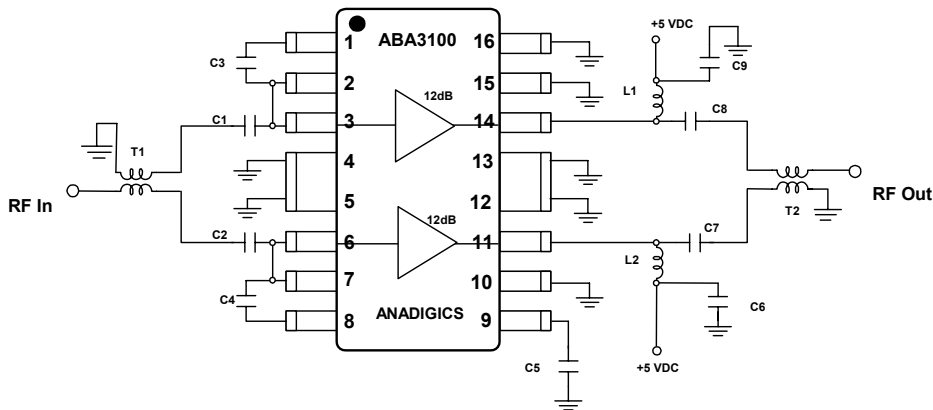

Pin	Description
1	Feedback #1
2	RF Input #1
3	RF Input #1
4	GND
5	GND
6	RF Input #2
7	RF Input #2
8	Feedback #2
9	Current Adjust
10	GND
11	RFOutput #2
12	GND
13	GND
14	RF Output #1
15	GND
16	GND

T2 Balun Drawing

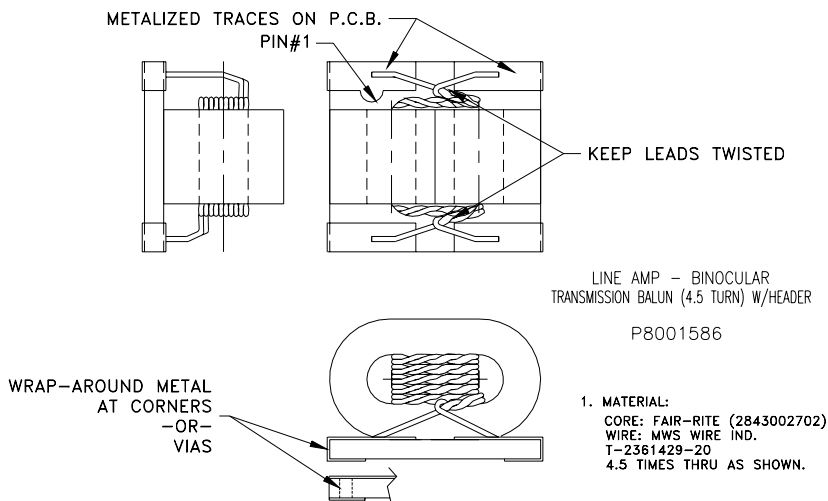

ABA3100 Test Fixture Layout

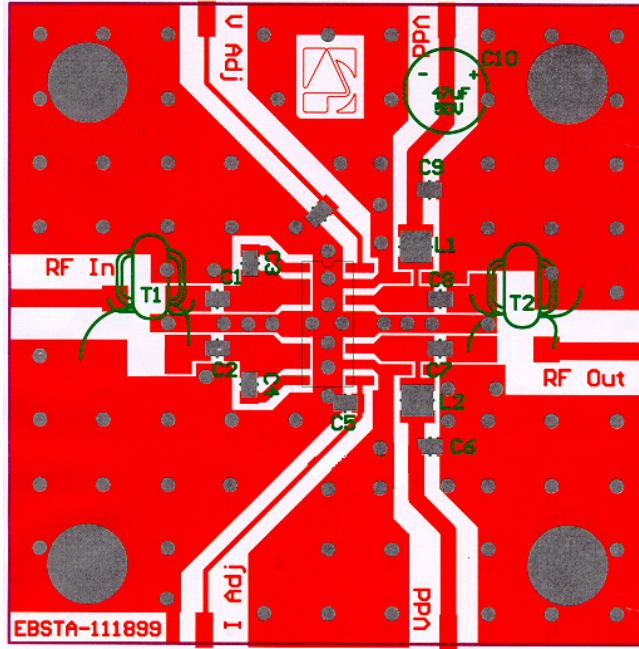

Parts List for ABA3100 Test Fixture

ITEM	DESCRIPTION	QTY	VENDOR	VENDOR P/N
C1 TO C9	0.01uF. CHIP CAP.	9	MURATA	GRM39X7R1103K25V
C10	47 uF ELEC. CAP.	1	DIGI-KEY CORP	P5275-ND
L1-L2	390 nH. CHIP INDUC.	2	COILCRAFT	1008CS-391XKBC
CONNECTORS	END LAUNCHED F CONNECTOR	2	LIGHTHORSE TECH	LT-FSF55NP
T1, T2 (BALUN)	FERRITE CORE WIRE	2	FAIR-RITE MWS WIRE IND.	2843002702 T-2361429-20
	PCB.	1	STAND. PRINTED CIRCUITS INC.	EBSTA-111899

Notes:

T2 Balun: 4.5 Times thru as shown. (DWG. No. P8001586)  
 Connectors tabs must be reduced by 150 mils.  
 Device must be soldered on PC board.

ABA3100 - Typical Noise Figure vs. Frequency

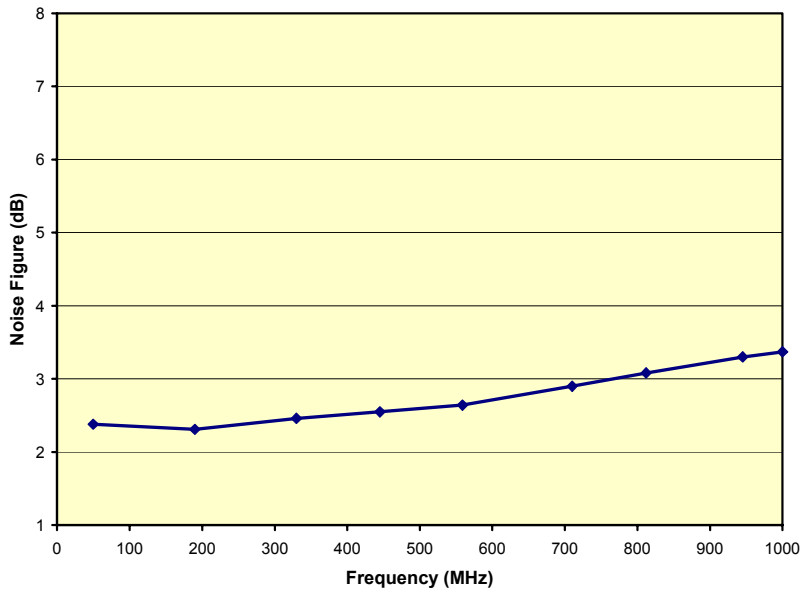

ABA3100 - Typical S11 vs. Frequency

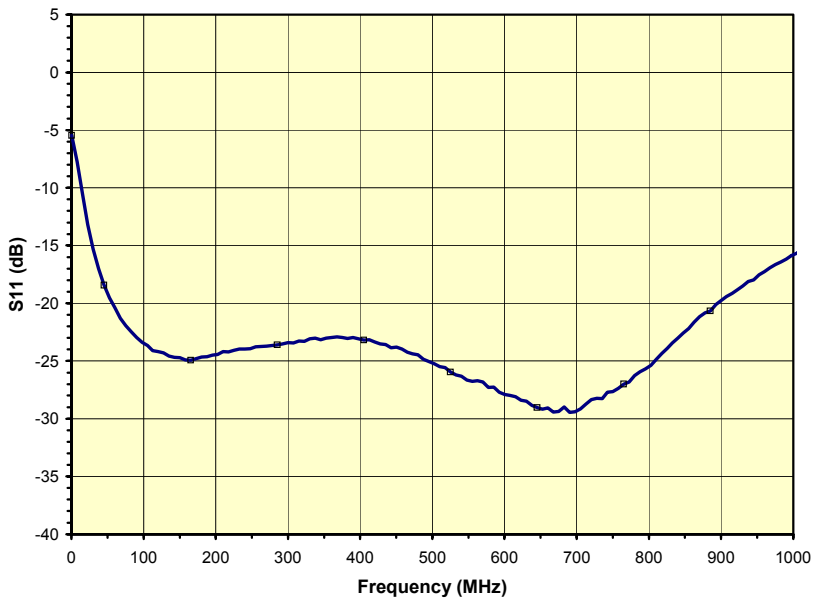

ABA3100 - Typical S21 vs. Frequency

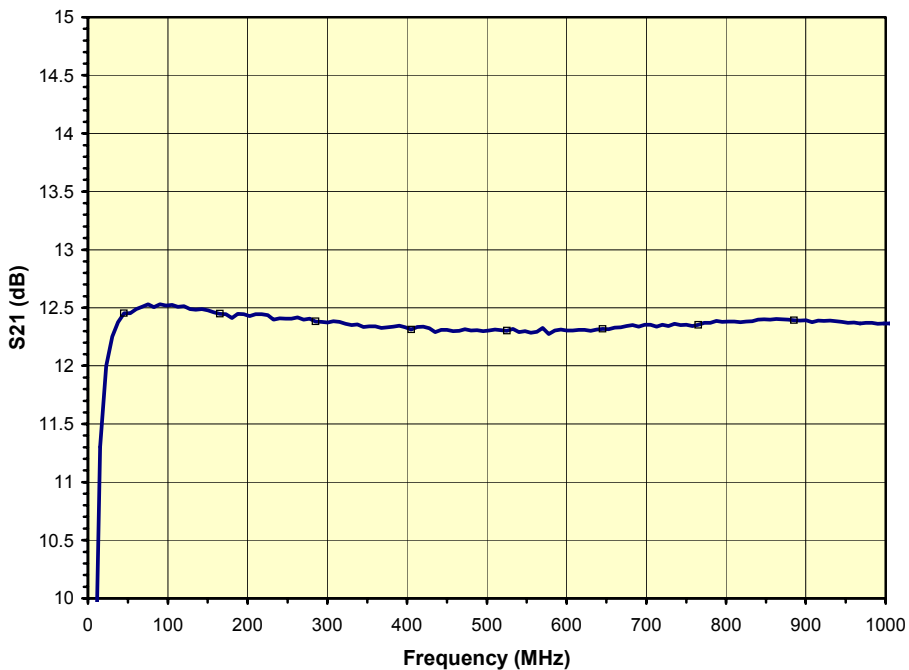

ABA3100 - Typical S12 vs. Frequency

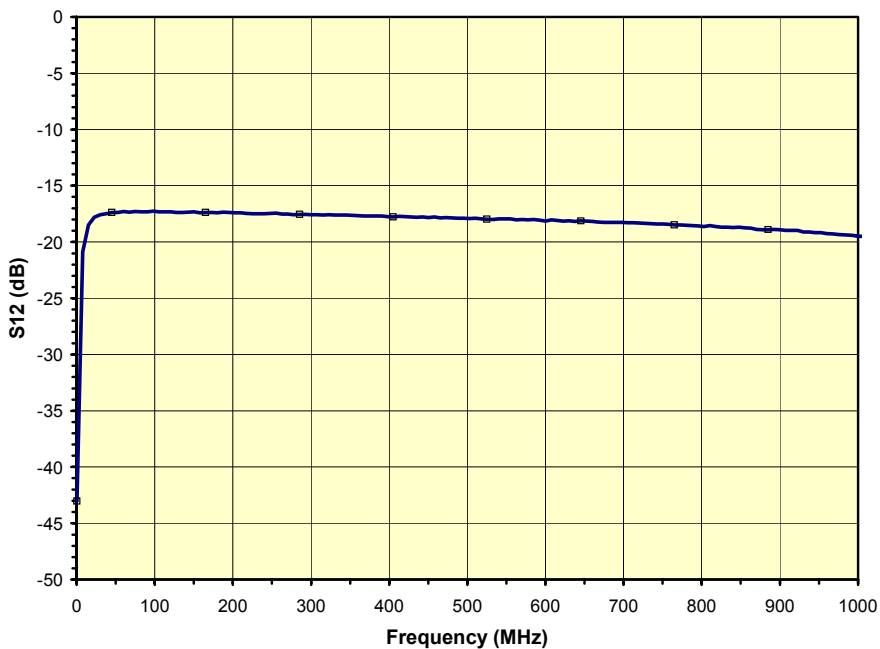

ABA3100 - Typical S22 vs. Frequency

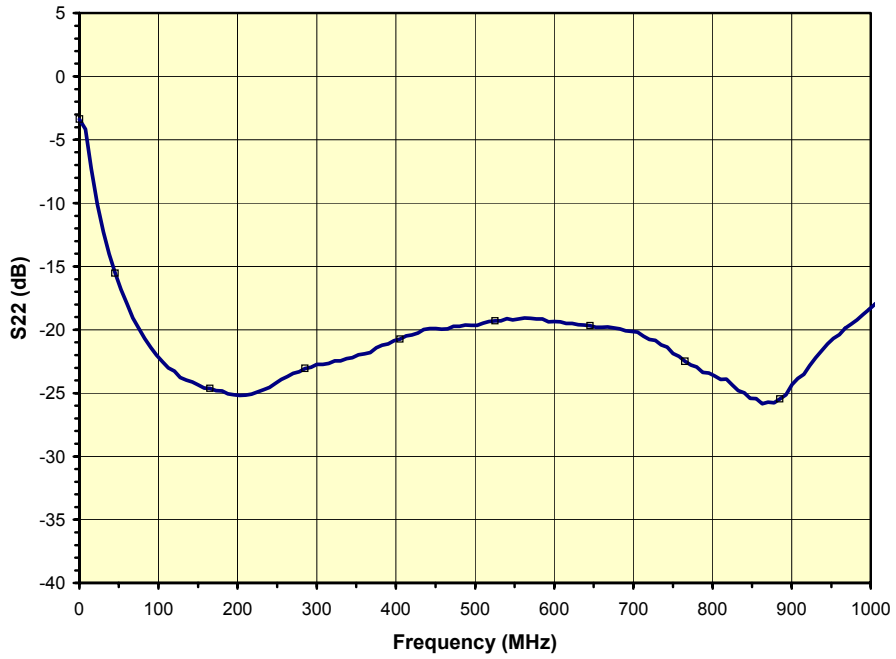

Package Outline

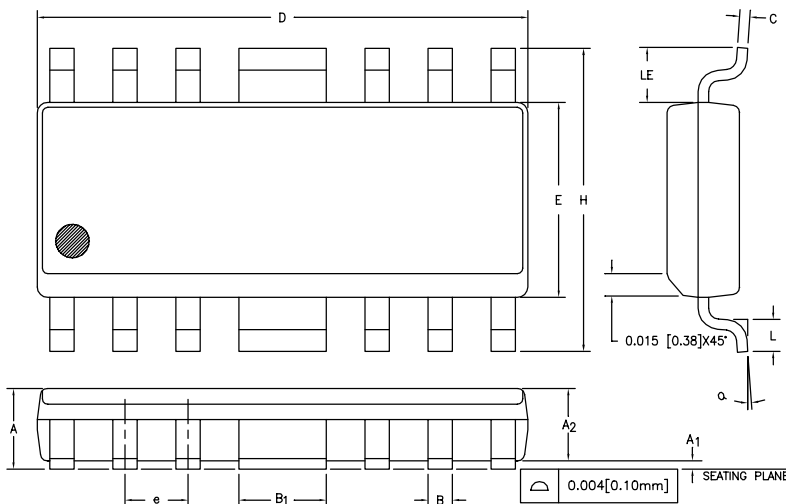

SYMBOL	INCHES		MILLIMETERS		NOTE
	MIN.	MAX.	MIN.	MAX.	
A	0.058	0.068	1.47	1.73	
A1	0.004	0.010	0.10	0.25	
A2	0.055	0.065	1.40	1.65	
B	0.013	0.020	0.33	0.50	
B1	0.062	0.070	1.58	1.78	
C	0.008	0.010	0.20	0.25	4
D	0.380	0.400	9.66	10.16	2
E	0.150	0.160	3.81	4.06	3
e	0.050	BSC	1.27	BSC	
H	0.226	0.244	5.74	6.20	
L	0.016	0.040	0.41	1.02	
LE	0.030	—	0.76	—	
α	0°	8°	0°	8°	

NOTES:

1. CONTROLLING DIMENSION: INCHES
2. DIMENSION "D" DOES NOT INCLUDE MOLD FLASH, PROTRUSIONS OR GATE BURRS. MOLD FLASH, PROTRUSIONS AND GATE BURRS SHALL NOT EXCEED 0.006 [0.15mm] PER SIDE.
3. DIMENSION "E" DOES NOT INCLUDE INTER-LEAD FLASH OR PROTRUSIONS. INTER-LEAD FLASH AND PROTRUSIONS SHALL NOT EXCEED 0.010 [0.25mm] PER SIDE.
4. MAXIMUM LEAD TWIST/SKEW TO BE ±0.005 [0.13mm].
5. LEAD THICKNESS AFTER PLATING TO BE 0.013 [0.33mm] MAXIMUM.

0-006



**ANADIGICS, Inc.**  
 35 Technology Drive  
 Warren, New Jersey 07059  
 Tel: (908) 668-5000  
 Fax: (908) 668-5132  
<http://www.anadigics.com>  
[Mktg@anadigics.com](mailto:Mktg@anadigics.com)

**IMPORTANT NOTICE**

ANADIGICS, Inc. reserves the right to make changes to its products or discontinue any product at any time without notice. The Advanced Product data sheets and product specifications contained in this data sheet are subject to change prior to a products formal introduction. The information in this data sheet has been carefully checked and is assumed to be reliable. However, ANADIGICS assumes no responsibility for inaccuracies. ANADIGICS strongly urges customers to verify that the information they are using is current before placing orders.

**WARNING**

ANADIGICS products are not intended for use in life support appliances, devices, or systems. Use of an ANADIGICS product in any such application without written consent is prohibited.