

**DESCRIPTION**

The SSI 32R2200R/2201R/2202R/2203R are BiCMOS monolithic integrated circuits designed for use with two-terminal recording heads. They provide a low noise read amplifier, write current control, and data protection circuitry for up to six channels. The SSI 2200R/2201R/2202R/2203R option provides internal 350Ω damping resistors. Damping resistors are switched in during write mode and switched out during read mode. The SSI 32R2200/2201/2202/2203R option does not provide damping resistors. Power supply fault protection is provided by disabling the write current generator during power sequencing. System write to read recovery time is significantly improved by making the read channel outputs high impedance. The device also offers multiple channel "servo bank write" capability to assist in servo writing operations.

The SSI 32R2200R/2201R/2202R/2203R require only a +5V power supply and are available in a variety of packages. The 32R2201R is hardware compatible with the SSI 32R4610AR and SSI 32R2020R Read/Write devices, while the 32R2202R is the no flip-flop version of the 32R2202R.

**FEATURES**

- +5V ± 10% supply
- Low power
  - PD = 105 mW read mode (Nom)
  - PD = 1.0 mW Idle (Max)
- High Performance:
  - Read mode gain = 300 V/V
  - Input noise = 0.5 nV/√Hz (Nom)
  - Input capacitance = 7 pF (Nom)
  - Write current range = 3-35 mA
  - Nominal write current rise/fall time = 7.7 ns (typical head)
  - Head voltage swing = 7.8 Vp-p (Nom)
- Servo bank-write capability
- Self switching damping resistance
- Write unsafe detection (continued)

3

**BLOCK DIAGRAM**

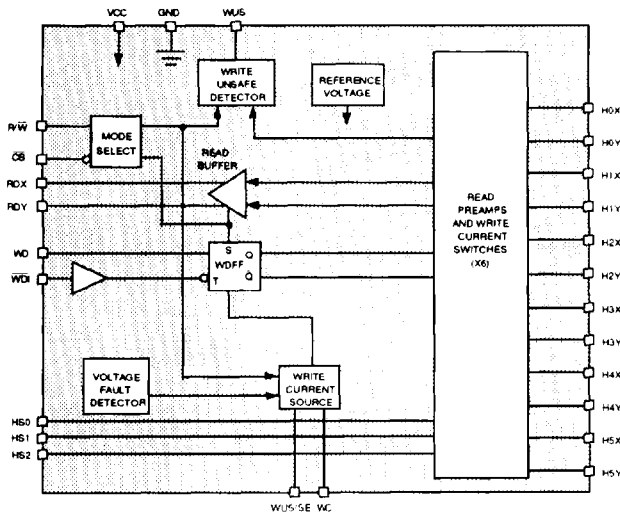

**PIN DIAGRAM**

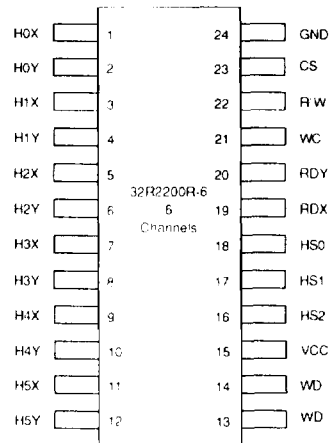

24-Lead SOV, SOL

CAUTION: Use handling procedures necessary for a static sensitive component.

# SSI 32R2200R/2201R/2202R/2203R

## +5V, 4-, 6-Channel Thin Film

### Read/Write Device

#### FEATURES *(continued)*

- Power supply fault protection
- Head short to ground protection
- Differential ECL-like (32R2200R/2202R) or TTL (32R2201R) write data inputs
- Write data flip/flop (32R2200R/2201R/2203R) or no flip/flop 32R2202R.

#### FUNCTIONAL DESCRIPTION

The SSI 32R2200R/2201R/2202R/2203R has the ability to address up to 6 two-terminal heads and provide write drive or read amplification. Mode control and head selection are described in Tables 1 and 2. The TTL inputs  $R/\bar{W}$  and  $\bar{CS}$  have internal pull-up resistors to prevent an accidental write condition. HS0, HS1 and HS2 have internal pull down resistors. Internal clamp circuitry will protect the IC from a head short to ground condition in any mode.

**TABLE 1: Mode Select**

$\bar{CS}$	$R/\bar{W}$	WUS/SE	Mode
0	0	*	Single Channel Write. See Table 2.
0	0	**	Servo Write.
0	1	X	Single Channel Read. See Table 2.
1	X	X	Idle.

\*WUS/SE is a WUS output unless pulled above VCC.

\*\*Servo write mode is activated through the WUS pin as described in the servo write mode section.

**TABLE 2: Head Select**

HS2	HS1	HS0	Head
0	0	0	0
0	0	1	1
0	1	0	2
0	1	1	3
1	0	0	4
1	0	1	5

# SSI 32R2200R/2201R/2202R/2203R +5V, 4-, 6-Channel Thin Film Read/Write Device

## WRITE MODE

Taking both  $\overline{CS}$  and  $R/\overline{W}$  low selects write mode which configures the SSI 32R2200R/2201R/2202R/2203R as a current switch and activates the Write Unsafe (WUS) detector circuitry. On the 32R2200R/2203R, head current is toggled between the X and Y side of the selected head on each low to high transition of  $\overline{WD}$ . On the 32R2201R, head current is toggled between the X and Y side of the selected head on each high to low transition of the Write Data Input (WDI). Note that a preceding Read to Write transition or Idle to Write transition initializes the Write Data Flip-Flop to pass write current into the "X" side of the device. In this case, the Y side is higher potential than the X side. On the 32R2202R, head current is toggled between the X and Y side of the selected head on each transition of  $\overline{WDX}$ - $\overline{WDY}$ . When the potential of  $\overline{WDX}$  is higher than  $\overline{WDY}$ , the potential on the X-side of the head is higher than the Y-side (HNY is sinking current). The magnitude of the write current (0-pk) is given by:

$$I_w = A_w \cdot \frac{V_{wc}}{R_{wc}} = K/R_{wc}$$

where  $A_w$  is the write current gain.

$R_{wc}$  is connected from pin  $\overline{WC}$  to GND. Note the actual head current  $I_x, y$  is given by:

$$k, y = \frac{I_w}{1 + R_h/R_d}$$

Where:

$R_h$  = Head resistance plus external wire resistance

$R_d$  = Damping resistance

In write mode a 350 $\Omega$  damping resistor is switched in across the  $H_x, H_y$  ports (32R2200R/2201R/2202R/2203R only).

## SERVO WRITE MODE

This mode allows for writing to multiple channels at once, which is useful during servo formatting. In this mode the write driver will drive all channels simultaneously.

To enable servo write mode follow these steps:

- (1) Place the device in the read mode (R/W high).
- (2) Set the head select lines to address head 1.

- (3) Pull the WUS output above  $V_{cc}$  by sourcing 10 mA of current into the pin. Two ways to source this current are: (a) use a voltage source set to  $V_{cc} + 1.9$  volts limited to 10 mA of current, or (b) use a resistor tied between WUS and a supply above  $V_{cc}$  to source the current. With 10 mA of current, WUS will rise to approximately  $V_{cc} + 1.5$  volts.
- (4) Allow at least 1  $\mu$ s setup.
- (5) While maintaining steps (2) and (3) above make R/W low, placing the device in servo write mode.

## POWER SUPPLY FAULT PROTECTION

A voltage fault detection circuit improves data security by disabling the write current generator during a voltage fault or power startup regardless of mode. Note that WUS does not necessarily turn on to flag a power supply fault condition.

## HEAD SHORT TO GROUND PROTECTION

The SSI 32R2200R/2201R/02R/03R provides a head short to ground protection circuit in write mode. If the selected head is shorted to ground the write current generator will turn off, the WUS flag will go high, and current will be limited to less than 1 mA out of the head port. Note that any unselected head is pulled to ground through internal circuitry. In the idle mode, all heads are similarly pulled to ground.

In read mode, current out of the selected head port will not exceed 3 mA if the head is shorted to ground.

## WRITE UNSAFE

Upon entering write mode, WUS is initialized low. Any of the following conditions will be indicated as a high level on the Write Unsafe, WUS, open collector output.

- Write data frequency too low
- Device in read mode
- Device not selected
- No head current
- Open head
- Head short to ground

To insure no false WUS trigger, the product of head current and head resistance ( $I_w \cdot R_h$ ) should be less than  $[0.14 (I_w) - 0.2]V$ , where  $I_w$  is in mA, for  $I_w$  range from 3 mA to 10 mA, and less than 1.2V for  $I_w$  range from 10 mA to 35 mA. The open head detect circuit is also disabled when write data frequency is above 10 MHz to prevent false WUS detect.

# SSI 32R2200R/2201R/2202R/2203R

## +5V, 4-, 6-Channel Thin Film

### Read/Write Device

---

#### FUNCTIONAL DESCRIPTION (continued)

**Write data frequency too low** is detected if the write data frequency falls below 500 kHz. Consult the WUS Safe to Unsafe timing for range of frequency detection.

**Device In read mode, Device in servo write mode and Chip disabled** will flag WUS if  $\overline{R/W}$  is high, if servo write mode is activated, or  $\overline{CS}$  is high.

**No head current** will flag WUS if  $R_{wc} = \infty$  and the selected head is present.

**Head opened** will flag WUS if  $R_h = \infty$  and the write data frequency is less than 10 MHz.

**Head short to ground** is described in the preceding paragraph.

#### READ MODE

The read mode configures the SSI 32R2200R/2201R/2202R/2203R as a low noise differential amplifier and deactivates the write current generator. The damping resistor is switched out of the circuit allowing a high impedance input to the read amplifier. The RDX and RDY outputs are driven by emitter followers and should be AC coupled to the load. The HnX, HnY inputs are non-inverting to the RDX, RDY outputs.

Note that in idle or write mode, the read amplifier is deactivated and RDX, RDY outputs become high impedance. This facilitates multiple R/W applications (wired-OR RDX, RDY) and minimizes voltage change when switching from write to read mode. Note also that the write current source is deactivated for both the read and idle mode.

#### IDLE MODE

Taking  $\overline{CS}$  high selects the idle mode which switches the RDX and RDY outputs into a high impedance state and deactivates the device. Power consumption in this mode is held to a minimum.

**SSI 32R2200R/2201R/2202R/2203R**  
**+5V, 4-, 6-Channel Thin Film**  
**Read/Write Device**

**PIN DESCRIPTION**

**CONTROL/STATUS**

NAME	TYPE	DESCRIPTION
$\overline{\text{CS}}$	I	Chip Select Input. A logical low level enables the device. This pin is an internal pull up.
$\text{R}/\overline{\text{W}}\dagger$	I	Read/Write. A logical high level enables read mode. A logical low level enables write mode. This pin is an internal pull up.
HS0, HS1, HS2	I	Head Select. Decoded address (internal pull down) selects one of 6 channels. See Table 2.
WUS/SE $\dagger$	I/O	Write Unsafe/Servo Enable. When in Servo Bank write mode, pulling this pin above Vcc enables servo bank write. See Servo write mode section. Otherwise, a high level indicates an unsafe writing condition. See WUS section.
WC $\dagger$	I	Write Current. A resistor to ground from WC sets the write current through the recording head.

**HEAD TERMINAL CONNECTIONS**

H0X-H5X H0Y-H5Y	I	X,Y Head Connections
--------------------	---	----------------------

**DATA INPUT/OUTPUT**

WDI $\dagger$ (32R2201R)	I	Write Data In. A negative transition of WDI changes the direction of current in the recording head.
WD, $\overline{\text{WD}}\dagger$ (32R2200R/2203R)	I	Differential Write Data In. A positive transition of WD- $\overline{\text{WD}}$ changes the direction of current in the recording head.
WDX,WDY (32R2202R)	I	Differential Write Data In. Each transition of WDX-WDY changes the direction of current in the recording.
RDX,RDY $\dagger$	O	Differential Read Data Out. Emitter follower output.

**POWER**

VCC	I	+5V power supply
GND	I	Ground

$\dagger$  When more than one Read/Write device is used, signals can be wire OR'ed.

**3**

# SSI 32R2200R/2201R/2202R/2203R

## +5V, 4-, 6-Channel Thin Film

### Read/Write Device

#### ELECTRICAL SPECIFICATIONS

Current maximums are currents with the highest absolute value.

#### ABSOLUTE MAXIMUM RATINGS

Operation beyond the maximum ratings may damage the device.

PARAMETER		RATING	
DC Supply Voltage	VCC	-0.3 to 6 VDC	
Write Current	I <sub>w</sub>	65 mA	
Digital Input Voltage	V <sub>in</sub>	-0.3 to VCC + 0.3 VDC	
Head Port Voltage	V <sub>H</sub>	-0.3 to VCC + 0.3 VDC	
WUS Pin Voltage	V <sub>wus</sub>	7.5 VDC	
Output Current	RDX,RDY	I <sub>o</sub>	-10 mA
	WUS	I <sub>wus</sub>	+15 mA
Junction Operating Temperature	T <sub>j</sub>	+125°C	
Storage Temperature		-65 to +150°	

#### RECOMMENDED OPERATING CONDITIONS

PARAMETER		CONDITIONS
DC Supply Voltage	VCC	5 ± 10%V
Ambient Operating Temperature	T <sub>a</sub>	0°C < T <sub>a</sub> < 75°C

#### TEST CONDITIONS

Recommended operating conditions apply.

PARAMETER		CONDITIONS
Write Current, I <sub>w</sub>		20 mA
Head Inductance, L <sub>h</sub>		1 μH
Head Resistance, R <sub>h</sub>		30Ω
WD Frequency		5 MHz
WD,WD rise/fall time	32R2200R/2202R/2203R	1 ns
WDI rise/fall time	32R2201R	1 ns

# SSI 32R2200R/2201R/2202R/2203R +5V, 4-, 6-Channel Thin Film Read/Write Device

## POWER DISSIPATION

Recommended operating conditions apply.

PARAMETER	CONDITIONS	MIN	NOM	MAX	UNIT
VCC Supply Current	read mode		21	30	mA
	write mode		42	55	mA
	idle mode		0.04	0.2	mA
Power Dissipation	read mode		105	165	mW
	write mode		210	303	mW
	idle mode		0.2	1	mW

## DIGITAL INPUTS

Input High Voltage HSX, CS/, R/ $\bar{W}$ , WDI	Vih		2			VDC
Input Low Voltage HSX, CS/, R/ $\bar{W}$ , WDI	Vil				0.8	VDC
Input High Current HSX, CS/, R/ $\bar{W}$ , WDI	Iih	Vih = 2.0V			100	$\mu$ A
Input Low Current HSX, CS/, R/ $\bar{W}$ , WDI	Iil	Vil = 0.8V	-0.4			mA
WD, $\bar{W}$ D Input High Voltage	Vih	32R2200R/2202R/2203R	Vcc - 1.1		Vcc - 0.4	VDC
WD, $\bar{W}$ D Input Low Voltage	Vil	32R2200R/2202R/2203R	Vcc - 2		Vih - 0.25	VDC
WD, $\bar{W}$ D Input High Current		Vih = Vcc-0.4V (32R2200R/2202R/2203R)		2	50	$\mu$ A
WD, $\bar{W}$ D Input Low Current		Vil = Vcc-1.45V (32R2200R/02R/03R)	-50	0	50	$\mu$ A
WUS Output Low Voltage	Vol	Iol = 2 mA max		0.2	0.5	VDC

3

# SSI 32R2200R/2201R/2202R/2203R

## +5V, 4-, 6-Channel Thin Film

### Read/Write Device

#### ELECTRICAL SPECIFICATIONS (continued)

##### WRITE CHARACTERISTICS

Test conditions apply unless otherwise specified.

PARAMETER	CONDITIONS	MIN	NOM	MAX	UNIT
Write Current Voltage $V_{wc}$			2		V
Write Current Gain $A_w$	$I_w = A_w \cdot V_{wc} / R_{wc}$		26		mA/mA
Write Current Constant "K"	$I_w = K / R_{wc}$	47	52	57	V
Differential Head Voltage Swing	Open Head, $I_w = 20$ mA	6.5	7.8		Vp-p
Head Differential $R_d$	32R2200/2201/2202/2203	2.4	3	3.6	k $\Omega$
Load Resistance	32R2200R/2201R/2202R/2203R	280	350	420	$\Omega$
WD Pulse Width (see Figure 1)	PWH	5			ns
	PWL	5			ns
Unselected Head Voltage			0	0.1	VDC
Unselected Head Current	DC		0	0.2	mA
VCC Fault Voltage	$I_w \leq 0.2$ mA	3.4	3.8	4.3	V
Head Current $H_{nX}, H_{nY}$	VCC fault condition	-200		200	$\mu$ A

##### SERVO WRITE CHARACTERISTICS

Write Current Range		3		25	mA
Write Current Matching	Between channels		$\pm 10\%$		
WUS/SE Voltage	Servo Bank Write Enabled		$V_{cc} + 1.5$	$V_{cc} + 1.9$	V
WUS/SE Sink Current	Servo Bank Write Enabled	10			mA



## SSI 32R2200R/2201R/2202R/2203R +5V, 4-, 6-Channel Thin Film Read/Write Device

### READ CHARACTERISTICS

Test conditions apply unless otherwise specified. CL (RDX, RDY) < 20 pF, RL (RDX, RDY) = 1 k $\Omega$ .

PARAMETER	CONDITIONS	MIN	NOM	MAX	UNIT
Differential Voltage Gain	Vin = 1 mVp-p @1 MHz	250	300	350	V/V
Voltage BW	-1 dB  Zs  < 5 $\Omega$ , Vin = 1 mVp-p	30	40		MHz
		-3 dB	65	85	
Input Noise Voltage	BW = 15 MHz, Lh = 0, Rh = 0		0.50	0.65	nV/ $\sqrt$ Hz
Input Noise Current			3.5		pA/ $\sqrt$ Hz
Differential Input Capacitance	Vin = 1 mVp-p, f = 5 MHz		7.5	12	pF
Differential Input Resistance	Vin = 1 mVp-p, f = 5 MHz	500	850		$\Omega$
Dynamic Range	AC input voltage where gain falls to 90% of its small signal gain value, f = 5 MHz	2	9		mVp-p
Common Mode Rejection Ratio	Vin = 0 VDC + 100 mVp-p @ 5 MHz	50	70		dB
Power Supply Rejection Ratio	100 mVp-p @ 5 MHz on VCC	50	70		dB
Channel Separation	Unselected channels driven with Vin = 0 VDC + 100 mVp-p	50	60		dB
Output Offset Voltage	Lh = 0, Rh = 0	-250		+250	mV
Single Ended Output Resistance	f = 5 MHz		35	50	$\Omega$
Output Current	AC coupled load, RDX to RDY	2	2.8		mA
RDX, RDY Common Mode Output Voltage			Vcc - 2.5		VDC

# SSI 32R2200R/2201R/2202R/2203R

## +5V, 4-, 6-Channel Thin Film

### Read/Write Device

#### ELECTRICAL SPECIFICATIONS (continued)

##### SWITCHING CHARACTERISTICS

Test conditions apply unless otherwise specified.

PARAMETER	CONDITIONS	MIN	NOM	MAX	UNIT	
R/W	Read to Write	R/W to 90% of write current	0.06	0.4	$\mu$ s	
	Write to Read	R/W to 90% of 100 mV Read signal envelope	0.1	0.4	$\mu$ s	
CS	Unselect to Read	CS to 90% of 100 mV 10 MHz Read signal envelope		0.6	$\mu$ s	
	Write to Unselect	CS to 10% of write current	0.04	0.6	$\mu$ s	
HS0,1 to any Head	To 90% of 100 mV 10 MHz Read signal envelope		0.06	0.6	$\mu$ s	
WUS	Safe to Unsafe (TD1)	Write mode, loss of WDI, WD transitions; Defines max WDI, WD period for WUS operation	0.6	2	3.6	$\mu$ s
	Unsafe to Safe (TD2)	Fault cleared: from first negative WDI transition		0.15	0.6	$\mu$ s
Head Current	WD to Ix - Iy (TD3)	from 50% points Lh = 0, Rh = 0		4	7	ns
	Asymmetry	WDI has 1 ns rise/fall time Lh = 0, Rh = 0		0.1	0.5	ns
	Rise/fall Time	10% to 90% points lw = 20 mA, Rh = 0, Lh = 0		1	3	ns
		lw = 20 mA, Rh = 30 $\Omega$ , Lh = 1 $\mu$ H		7.7	10	ns

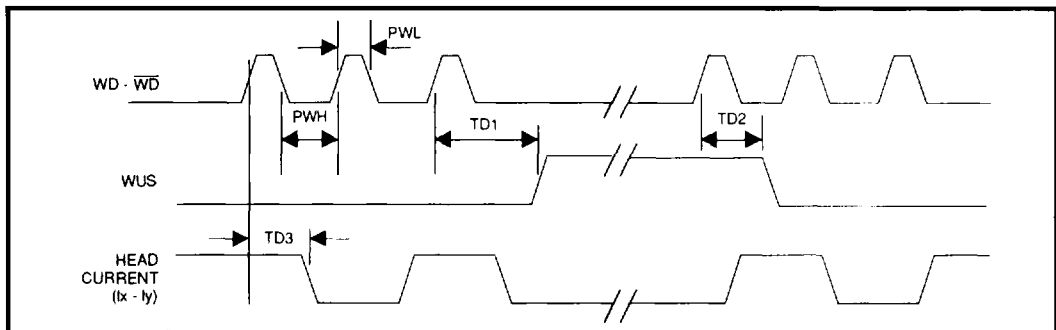
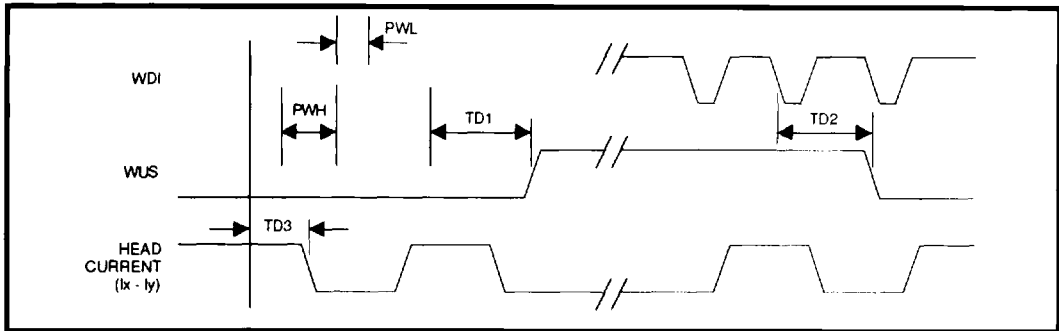

FIGURE 1: 32R2200R/2203R Write Mode Timing Diagram

**SSI 32R2200R/2201R/2202R/2203R**  
**+5V, 4-, 6-Channel Thin Film**  
**Read/Write Device**



**FIGURE 2: 32R2201R Write Mode Timing Diagram**

**3**

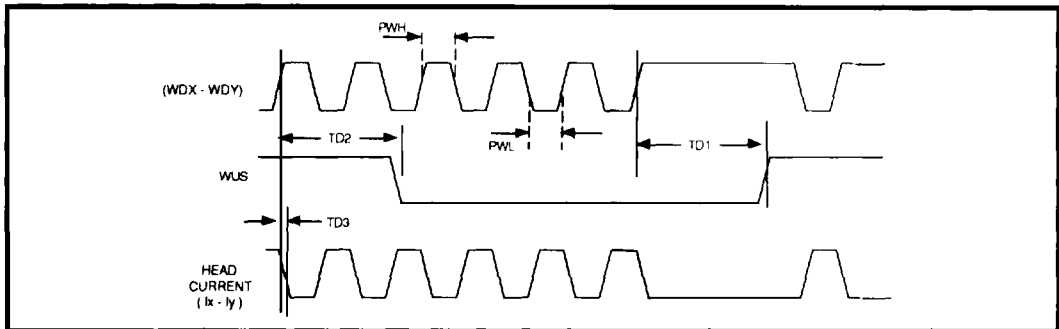

**FIGURE 3: 32R2202R Write Mode Timing Diagram**

# SSI 32R2200R/2201R/2202R/2203R

## +5V, 4-, 6-Channel Thin Film

### Read/Write Device

#### PACKAGE PIN DESIGNATIONS

(Top View)

CAUTION: Use handling procedures necessary for a static sensitive component.

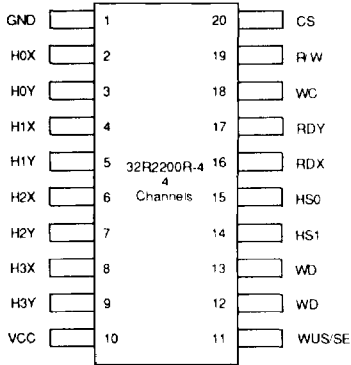

20-Lead SOV, SOL

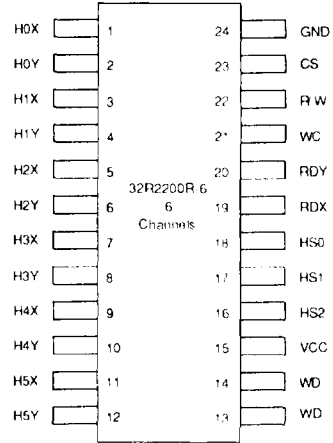

24-Lead SOV, SOL

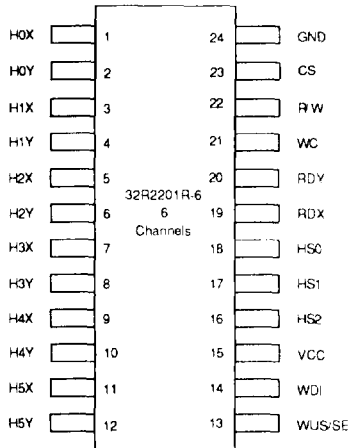

24-Lead SOV, SOL

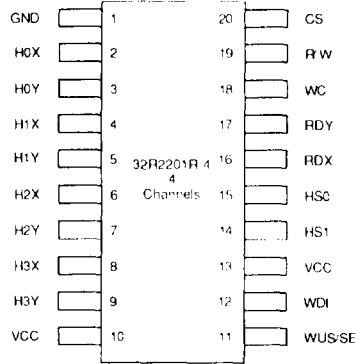

20-Lead SOV, SOL

# SSI 32R2200R/2201R/2202R/2203R +5V, 4-, 6-Channel Thin Film Read/Write Device

## PACKAGE PIN DESIGNATIONS (Top View)

CAUTION: Use handling procedures necessary for a static sensitive component.

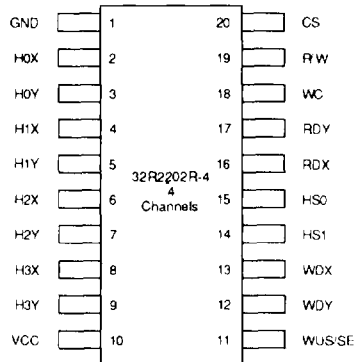

**4-Channel  
20-Lead SOV, SOL**

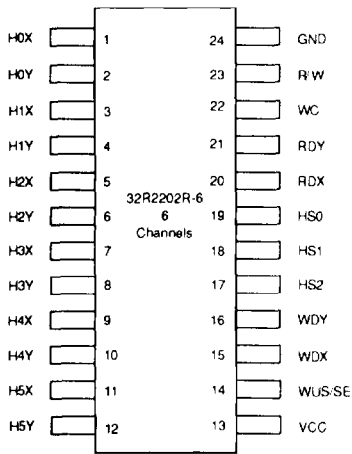

**6-Channel  
24-Lead SOV, SOL**

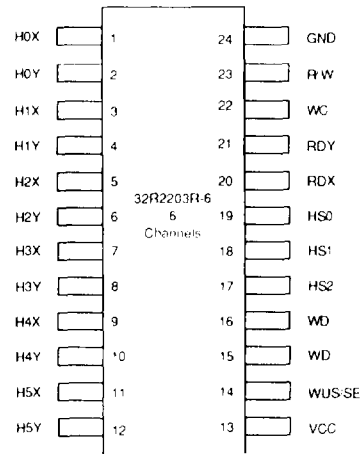

**6-Channel  
24-Lead SOV, SOL**

**Advance Information:** Indicates a product still in the design cycle, and any specifications are based on design goals only. Do not use for final design.

No responsibility is assumed by Silicon Systems for use of this product nor for any infringements of patents and trademarks or other rights of third parties resulting from its use. No license is granted under any patents, patent rights or trademarks of Silicon Systems. Silicon Systems reserves the right to make changes in specifications at any time without notice. Accordingly, the reader is cautioned to verify that the data sheet is current before placing orders.

Silicon Systems, Inc., 14351 Myford Road, Tustin, CA 92680-7022 (714) 573-6000, FAX (714) 573-6914