

VOLTAGE REGULATOR (with Wide Input Voltage Range) with RESET

NO.EA-081-090803

OUTLINE

The R1150H series are CMOS-based voltage regulator (VR) ICs equipped with a voltage detector (V_{DET}). VR function of the R1150Hxxxx has features of low dropout voltage, high output voltage accuracy, and ultra-low supply current. Each of the R1150HxxxxA series includes also a chip enable circuit. The output of built-in voltage detector is Nch open drain type. The R1150HxxxC/D have a pin for connecting external capacitor to set a certain reset delay time instead of chip enable control pin.

The regulator output voltage and the detector threshold voltage are fixed in the IC, Output Voltage Accuracy is $\pm 2.0\%$, while Detector Threshold Accuracy is $\pm 2.5\%$. The R1150HxxxxA (with chip enable function) and R1150HxxxC series can supervise input voltage by the built-in detector. R1150HxxxB can supervise SENSE pin voltage by the built-in detector. R1150HxxxD type can supervise V_{OUT} voltage, or Regulator Output Voltage of this IC itself.

Since the package for these ICs is the SOT-89-5 package, high density mounting of the ICs on boards is possible.

FEATURES

- Supply Current Typ. $7.0\mu A$
- Input Voltage Max. 24.0V
- Output Voltage (VR) 2.1V to 14.0V
- Detector Threshold Voltage (V_{DET}) 2.0V to 15.0V (R1150HxxxB/C/D)
2.3V to 15.0V (R1150HxxxxA)
- Output Voltage Accuracy $\pm 2.0\%$ (VR), $\pm 2.5\%$ (VD)
- Output Current Min. 150mA ($V_{OUT}=5.0V$)
- Package SOT-89-5
- Built-in Fold-Back Protection Circuit Typ. 45mA (Current at short mode)
- Built-in Thermal Shutdown Circuit (VR) Thermal Shutdown Temperature ; Typ. $150^{\circ}C$
Released Temperature ; Typ. $120^{\circ}C$
- Monitoring V_{DD} voltage R1150HxxxA/C
- Monitoring sense pin (SENSE) voltage R1150HxxxB
- Monitoring V_{OUT} pin voltage R1150HxxxD

APPLICATIONS

- Power source and Reset circuit for cameras, videos and mobile telecommunication equipment.
- Power source and Reset circuit for battery-operated equipment.
- Power source and Reset circuit for home appliances.

BLOCK DIAGRAMS

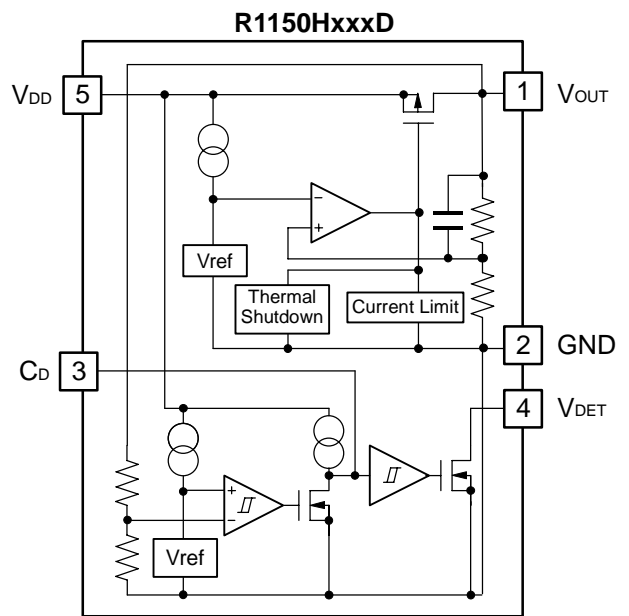
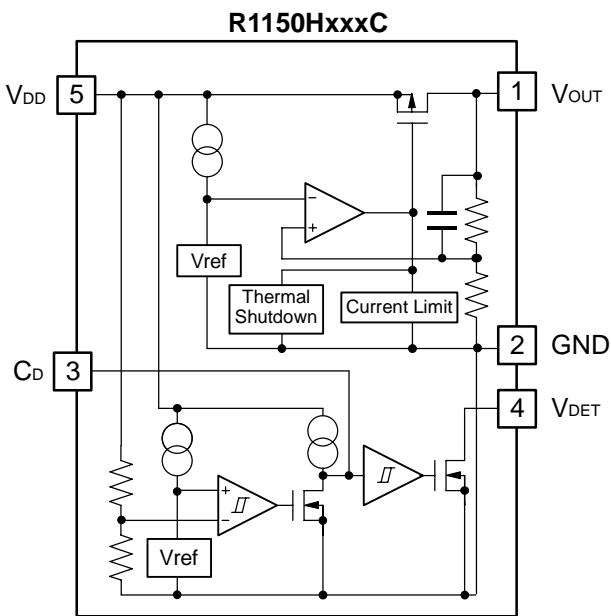
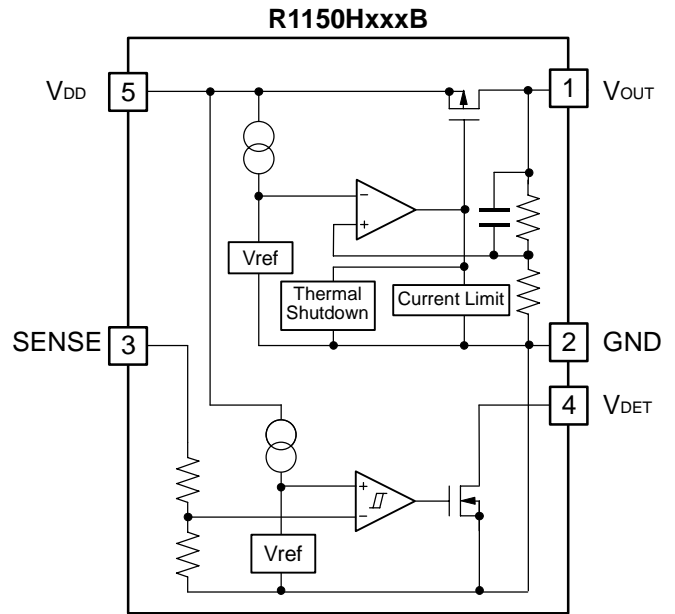
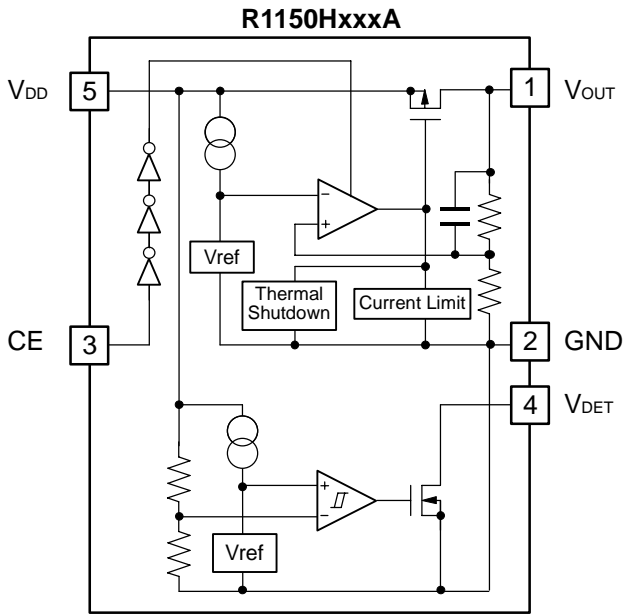

SELECTION GUIDE

The output voltage and the usage of pin No.3 (as a kind of types in the R1150Hxxxx series) can be selected at the user's request. The selection can be made with designating the part number as follows;

R1150Hxxxx-xx-x ←Part Number
 ↑ ↑ ↑ ↑ ↑
 a b c d e

Code	Contents
a	Designation of package type; H: SOT-89-5
b	Serial Number for Voltage Setting
c	Designation of option; A: Built-in Chip Enable Circuit (V_{DET} supervises V_{IN} level.) B: V_{DET} supervises SENSE pin. C: Used with an external capacitor for setting output delay time of V_{DET} . (V_{DET} supervises V_{IN} .) D: Used with an external capacitor for setting output delay time of V_{DET} . (V_{DET} supervises V_{OUT} .)
d	Designation of Taping Type; (Refer to Taping Specifications)
e	Designation of composition of pin plating: F: Lead free solder plating

PIN CONFIGURATION

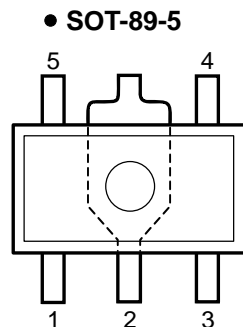

PIN DESCRIPTION

Pin No.	Symbol	Description
1	V_{OUT}	Voltage Regulator Output Pin
2	GND	Ground Pin
3	CE (A type)	Chip Enable Pin
	SENSE (B type)	Sense Pin for Voltage Detector
	C_D (C/D type)	Pin for External Capacitor for Setting Output Delay of Voltage Detector
4	V_{DET}	Voltage Detector Output Pin
5	V_{DD}	Input Pin

ABSOLUTE MAXIMUM RATINGS

Symbol	Item	Rating	Unit
V_{IN}	Input Voltage	26.0	V
V_{CE}	Input Voltage (CE Input Pin, A Version)	-0.3 to $V_{IN}+0.3$	V
V_{SENSE}	Input Voltage (SENSE Input Pin, B Version)	-0.3 to $V_{IN}+0.3$	V
V_{CD}	Input Voltage (C_D Input Pin, C/D Version)	-0.3 to $V_{IN}+0.3$	V
V_{DET}	Output Voltage (V_{DET} Output Pin)	-0.3 to 26.0	V
V_{OUT}	Output Voltage	-0.3 to $V_{IN}+0.3$	V
I_{OUT1}	Output Current (VR)	250	mA
I_{OUT2}	Output Current (VD)	10	mA
P_D	Power Dissipation (SOT-89-5)*	900	mW
T_{opt}	Operating Temperature	-40 to 85	°C
T_{stg}	Storage Temperature	-55 to 125	°C

*) For Power Dissipation, please refer to PACKAGE INFORMATION.

ABSOLUTE MAXIMUM RATINGS

Electronic and mechanical stress momentarily exceeded absolute maximum ratings may cause the permanent damages and may degrade the life time and safety for both device and system using the device in the field. The functional operation at or over these absolute maximum ratings is not assured.

ELECTRICAL CHARACTERISTICS

• R1150HxxxA

T_{opt}=25°C

Symbol	Item	Conditions	Min.	Typ.	Max.	Unit
V _{IN}	Input Voltage				24.0	V
I _{SS}	Supply Current	V _{IN} =V _{CE} V _{OUT} ≥ (-V _{DET}): V _{IN} =V _{OUT} +2.0V V _{OUT} < (-V _{DET}): V _{IN} =(-V _{DET})+2.0V		7	14	μA
I _{standby}	Standby Current	V _{DD} =24V, V _{CE} =0V	Refer to Supply Current Table			
T _{TSD}	Thermal Shutdown Temperature	Junction Temperature		150		°C
T _{TSR}	Thermal Shutdown Released Temperature	Junction Temperature		120		°C

VR

T_{opt}=25°C

Symbol	Item	Conditions	Min.	Typ.	Max.	Unit
V _{OUT}	Output Voltage	V _{IN} =V _{OUT} +2.0V, I _{OUT} =20mA	×0.98		×1.02	V
I _{OUT1}	Output Current	V _{IN} =V _{OUT} +2.0V	Refer to Output Current Table			
ΔV _{OUT} /ΔI _{OUT}	Load Regulation	V _{IN} =V _{OUT} +2.0V 1mA ≤ I _{OUT} ≤ 40mA	Refer to Load Regulation Table			
ΔV _{OUT} /ΔV _{IN}	Line Regulation	V _{IN} =V _{OUT} +2.0V, I _{OUT} =20 mA V _{OUT} +1V ≤ V _{IN} ≤ 24V		0.05	0.15	%/V
V _{DIF}	Dropout Voltage	I _{OUT} =20mA	Refer to Dropout Voltage Table			
ΔV _{OUT} /ΔT _{opt}	Output Voltage Temperature Coefficient	V _{IN} =V _{OUT} +2.0V, I _{OUT} =20mA -40°C ≤ T _{opt} ≤ 85°C		±100		ppm/°C
I _{lim}	Short Current Limit	V _{OUT} =0V		45		mA
V _{CEH}	CE "H" Input Voltage		1.5		V _{IN}	V
V _{CEL}	CE "L" Input Voltage		0		0.25	V

VD

T_{opt}=25°C

Symbol	Item	Conditions	Min.	Typ.	Max.	Unit
-V _{DET}	Detector Threshold		×0.975		×1.025	V
V _{HYS}	Detector Threshold Hysteresis		-V _{DET} ×0.03	-V _{DET} ×0.05	-V _{DET} ×0.07	V
I _{OUT2}	Output Current (Driver Output Pin)	Refer to Test Conditions for Output Current Table	0.17			mA
V _{DDL}	Minimum Operating Voltage	*Note 1		0.9	1.2	V
Δ-V _{DET} /ΔT _{opt}	Detector Threshold Temperature Coefficient	-40°C ≤ T _{opt} ≤ 85°C		±100		ppm/°C
t _{PLH}	Output Delay Time	*Note 2		0.5	1.0	ms

Note 1) This item means V_{DD} Voltage when Output Voltage is equal or less than 0.1V.
(Pull-up Resistor=470kΩ, Pull up Voltage=5V)

Note 2) V_{DET} pin is pulled up to V_{DD} via 470kΩ. t_{PLH} means time interval from rising edge of V_{DD} from (-V_{DET})-2.0V to (-V_{DET})+2.0V to the point of Output Voltage being 80% of pull-up voltage.

- Standby Current (T_{opt}=25°C)

Detector Threshold Voltage -V _{DET} (V)	Supply Current (μA)	
	Typ.	Max.
2.3V ≤ (-V _{DET}) ≤ 3.0V	2.5	5.0
3.1V ≤ (-V _{DET}) ≤ 15.0V	3.0	6.0

VR part

- Output Current (T_{opt}=25°C)

Output Voltage V _{OUT} (V)	Output Current (mA)	
	Min.	Typ.
2.1V ≤ V _{OUT} ≤ 2.9V	90	140
3.0V ≤ V _{OUT} ≤ 4.0V	120	170
4.1V ≤ V _{OUT} ≤ 14.0V	150	200

- Load Regulation (T_{opt}=25°C)

Output Voltage V _{OUT} (V)	Load Regulation (mV)	
	Typ.	Max.
2.1V ≤ V _{OUT} ≤ 3.0V	15	35
3.1V ≤ V _{OUT} ≤ 5.0V	25	45
5.1V ≤ V _{OUT} ≤ 10.0V	40	65
10.1V ≤ V _{OUT} ≤ 14.0V	50	80

- Dropout Voltage (T_{opt}=25°C)

Output Voltage V _{OUT} (V)	Dropout Voltage (V)	
	Typ.	Max.
2.1V ≤ V _{OUT} ≤ 2.4V	0.40	0.60
2.5V ≤ V _{OUT} ≤ 3.0V	0.30	0.40
3.1V ≤ V _{OUT} ≤ 7.0V	0.25	0.35
7.1V ≤ V _{OUT} ≤ 10.0V	0.27	0.45
10.1V ≤ V _{OUT} ≤ 14.0V	0.30	0.50

VD part

- Test Conditions for Output Current

Detector Threshold Voltage -V _{DET} (V)	Conditions
2.3V ≤ (-V _{DET}) ≤ 15.0V	V _{IN} =2V, V _{DS} =0.05V

RECOMMENDED OPERATING CONDITIONS (ELECTRICAL CHARACTERISTICS)

All of electronic equipment should be designed that the mounted semiconductor devices operate within the recommended operating conditions. The semiconductor devices cannot operate normally over the recommended operating conditions, even if when they are used over such conditions by momentary electronic noise or surge. And the semiconductor devices may receive serious damage when they continue to operate over the recommended operating conditions.

● R1150HxxxB

T_{opt}=25°C

Symbol	Item	Conditions	Min.	Typ.	Max.	Unit
V _{IN}	Input Voltage				24.0	V
I _{SS}	Supply Current	V _{OUT} ≥ (-V _{DET}): V _{IN} =SENSE=V _{OUT} +2.0V V _{OUT} < (-V _{DET}): V _{IN} =SENSE=(-V _{DET})+2.0V		7	14	μA
T _{TSD}	Thermal Shutdown Temperature	Junction Temperature		150		°C
T _{TSR}	Thermal Shutdown Temperature	Junction Temperature		120		°C

VR

T_{opt}=25°C

Symbol	Item	Conditions	Min.	Typ.	Max.	Unit
V _{OUT}	Output Voltage	V _{IN} =V _{OUT} +2.0V I _{OUT} =20mA	×0.98		×1.02	V
I _{OUT1}	Output Current	V _{IN} =V _{OUT} +2.0V	Refer to Output Current Table			
ΔV _{OUT} /ΔI _{OUT}	Load Regulation	V _{IN} =V _{OUT} +2.0V 1mA ≤ I _{OUT} ≤ 40mA	Refer to Load Regulation Table			
ΔV _{OUT} /ΔV _{IN}	Line Regulation	I _{OUT} =20mA V _{OUT} +1V ≤ V _{IN} ≤ 24V		0.05	0.15	%/V
V _{DIF}	Dropout Voltage	I _{OUT} =20mA	Refer to Dropout Voltage Table			
ΔV _{OUT} /ΔT _{opt}	Output Voltage Temperature Coefficient	V _{IN} =V _{OUT} +2.0V I _{OUT} =20mA -40°C ≤ T _{opt} ≤ 85°C		±100		ppm/°C
I _{lim}	Short Current Limit	V _{OUT} =0V		45		mA

VD

T_{opt}=25°C

Symbol	Item	Conditions	Min.	Typ.	Max.	Unit
-V _{DET}	Detector Threshold		×0.975		×1.025	V
V _{HYS}	Detector Threshold Hysteresis		-V _{DET} ×0.03	-V _{DET} ×0.05	-V _{DET} ×0.07	V
I _{OUT2}	Output Current (Driver Output Pin)	Refer to Test Conditions for Output Current Table	0.17			mA
V _{DDL}	Minimum Operating Voltage	*Note 1		0.9	1.2	V
Δ-V _{DET} /ΔT _{opt}	Detector Threshold Temperature Coefficient	-40°C ≤ T _{opt} ≤ 85°C		±100		ppm/°C
t _{PLH}	Output Delay Time	*Note 2		1.0	1.5	ms

Note 1) This item means V_{DD} Voltage when Output Voltage is equal or less than 0.1V.
(Pull-up Resistor=470kΩ, Pull up Voltage=5V)

Note 2) V_{DET} pin is pulled up to V_{DD} via 470kΩ. t_{PLH} means time interval from rising edge of V_{DD} from (-V_{DET})-2.0V to (-V_{DET})+2.0V to the point of Output Voltage being 80% of pull-up voltage.

- Output Current (Topt=25°C)

Output Voltage V _{OUT} (V)	Output Current (mA)	
	Min.	Typ.
2.1V ≤ V _{OUT} ≤ 2.9V	90	140
3.0V ≤ V _{OUT} ≤ 4.0V	120	170
4.1V ≤ V _{OUT} ≤ 14.0V	150	200

VR part

- Load Regulation (Topt=25°C)

Output Voltage V _{OUT} (V)	Load Regulation (mV)	
	Typ.	Max.
2.1V ≤ V _{OUT} ≤ 3.0V	15	35
3.1V ≤ V _{OUT} ≤ 5.0V	25	45
5.1V ≤ V _{OUT} ≤ 10.0V	40	65
10.1V ≤ V _{OUT} ≤ 14.0V	50	80

- Dropout Voltage (Topt=25°C)

Output Voltage V _{OUT} (V)	Dropout Voltage (V)	
	Typ.	Max.
2.1V ≤ V _{OUT} ≤ 2.4V	0.40	0.60
2.5V ≤ V _{OUT} ≤ 3.0V	0.30	0.40
3.1V ≤ V _{OUT} ≤ 7.0V	0.25	0.35
7.1V ≤ V _{OUT} ≤ 10.0V	0.27	0.45
10.1V ≤ V _{OUT} ≤ 14.0V	0.30	0.50

VD part

- Test Conditions for Output Current

Detector Threshold Voltage -V _{DET} (V)	Conditions
2.1V ≤ (-V _{DET}) ≤ 15.0V	V _{IN} =2V, V _{DS} =0.05V
(-V _{DET})=2.0	V _{IN} =1.9V, V _{DS} =0.05V

RECOMMENDED OPERATING CONDITIONS (ELECTRICAL CHARACTERISTICS)

All of electronic equipment should be designed that the mounted semiconductor devices operate within the recommended operating conditions. The semiconductor devices cannot operate normally over the recommended operating conditions, even if when they are used over such conditions by momentary electronic noise or surge. And the semiconductor devices may receive serious damage when they continue to operate over the recommended operating conditions.

● R1150HxxxC

T_{opt}=25°C

Symbol	Item	Conditions	Min.	Typ.	Max.	Unit
V _{IN}	Input Voltage				24.0	V
I _{SS}	Supply Current	V _{OUT} ≥ (-V _{DET}): V _{IN} =V _{OUT} +2.0V V _{OUT} < (-V _{DET}): V _{IN} =(-V _{DET})+2.0V		7	14	μA
T _{TSD}	Thermal Shutdown Temperature	Junction Temperature		150		°C
T _{TSR}	Thermal Shutdown Released Temperature	Junction Temperature		120		°C

VR

T_{opt}=25°C

Symbol	Item	Conditions	Min.	Typ.	Max.	Unit
V _{OUT}	Output Voltage	V _{IN} =V _{OUT} +2.0V I _{OUT} =20mA	×0.98		×1.02	V
I _{OUT1}	Output Current	V _{IN} =V _{OUT} +2.0V	Refer to Output Current Table			
ΔV _{OUT} /ΔI _{OUT}	Load Regulation	V _{IN} =V _{OUT} +2.0V 1mA ≤ I _{OUT} ≤ 40mA	Refer to Load Regulation Table			
ΔV _{OUT} /ΔV _{IN}	Line Regulation	I _{OUT} =20mA V _{OUT} +1V ≤ V _{IN} ≤ 24V		0.05	0.15	%/V
V _{DIF}	Dropout Voltage	I _{OUT} =20mA	Refer to Dropout Voltage Table			
ΔV _{OUT} /ΔT _{opt}	Output Voltage Temperature Coefficient	V _{IN} =V _{OUT} +2.0V I _{OUT} =20mA -40°C ≤ T _{opt} ≤ 85°C		±100		ppm/°C
I _{lim}	Short Current Limit	V _{OUT} =0V		45		mA

VD

T_{opt}=25°C

Symbol	Item	Conditions	Min.	Typ.	Max.	Unit
-V _{DET}	Detector Threshold		×0.975		×1.025	V
V _{HYS}	Detector Threshold Hysteresis		-V _{DET} ×0.03	-V _{DET} ×0.05	-V _{DET} ×0.07	V
I _{OUT2}	Output Current (Driver Output Pin)	Refer to Test Conditions for Output Current Table	0.17			mA
V _{DDL}	Minimum Operating Voltage	*Note 1		0.9	1.2	V
Δ-V _{DET} /ΔT _{opt}	Detector Threshold Temperature Coefficient	-40°C ≤ T _{opt} ≤ 85°C		±100		ppm/°C
t _{PLH}	Output Delay Time	C _D =4.7nF, *Note 2	20	30	50	ms

Note 1) This item means V_{DD} Voltage when Output Voltage is equal or less than 0.1V.
(Pull-up Resistor=470kΩ, Pull up Voltage=5V)

Note 2) V_{DET} pin is pulled up to V_{DD} via 470kΩ. t_{PLH} means time interval from rising edge of V_{DD} from (-V_{DET})-2.0V to (-V_{DET})+2.0V to the point of Output Voltage being 80% of pull-up voltage.

- Output Current (T_{opt}=25°C)

Output Voltage V _{OUT} (V)	Output Current (mA)	
	Min.	Typ.
2.1V ≤ V _{OUT} ≤ 2.9V	90	140
3.0V ≤ V _{OUT} ≤ 4.0V	120	170
4.1V ≤ V _{OUT} ≤ 14.0V	150	200

- Load Regulation (T_{opt}=25°C)

Output Voltage V _{OUT} (V)	Load Regulation (mV)	
	Typ.	Max.
2.1V ≤ V _{OUT} ≤ 3.0V	15	35
3.1V ≤ V _{OUT} ≤ 5.0V	25	45
5.1V ≤ V _{OUT} ≤ 10.0V	40	65
10.1V ≤ V _{OUT} ≤ 14.0V	50	80

- Dropout Voltage (T_{opt}=25°C)

Output Voltage V _{OUT} (V)	Dropout Voltage (V)	
	Typ.	Max.
2.1V ≤ V _{OUT} ≤ 2.4V	0.40	0.60
2.5V ≤ V _{OUT} ≤ 3.0V	0.30	0.40
3.1V ≤ V _{OUT} ≤ 7.0V	0.25	0.35
7.1V ≤ V _{OUT} ≤ 10.0V	0.27	0.45
10.1V ≤ V _{OUT} ≤ 14.0V	0.30	0.50

- Test Conditions for Output Current

Detector Threshold Voltage -V _{DET} (V)	Conditions
2.1V ≤ (-V _{DET}) ≤ 15.0V	V _{IN} =2V, V _{DS} =0.05V
(-V _{DET})=2.0	V _{IN} =1.9V, V _{DS} =0.05V

RECOMMENDED OPERATING CONDITIONS (ELECTRICAL CHARACTERISTICS)

All of electronic equipment should be designed that the mounted semiconductor devices operate within the recommended operating conditions. The semiconductor devices cannot operate normally over the recommended operating conditions, even if when they are used over such conditions by momentary electronic noise or surge. And the semiconductor devices may receive serious damage when they continue to operate over the recommended operating conditions.

● R1150HxxxD

T_{opt}=25°C

Symbol	Item	Conditions	Min.	Typ.	Max.	Unit
V _{IN}	Input Voltage				24.0	V
I _{SS}	Supply Current	V _{IN} =V _{OUT} +2.0V		7	14	μA
T _{SD}	Thermal Shutdown Temperature			150		°C
T _{SR}	Thermal Shutdown Released Temperature	Junction Temperature		120		°C

VR

T_{opt}=25°C

Symbol	Item	Conditions	Min.	Typ.	Max.	Unit
V _{OUT}	Output Voltage	V _{IN} =V _{OUT} +2.0V I _{OUT} =20mA	×0.98		×1.02	V
I _{OUT}	Output Current	V _{IN} =V _{OUT} +2.0V	Refer to Output Current Table			
ΔV _{OUT} /ΔI _{OUT}	Load Regulation	V _{IN} =V _{OUT} +2.0V 1mA ≤ I _{OUT} ≤ 40mA	Refer to Load Regulation Table			
ΔV _{OUT} /ΔV _{IN}	Line Regulation	I _{OUT} =20mA V _{OUT} +1V ≤ V _{IN} ≤ 24V		0.05	0.15	%/V
V _{DIF}	Dropout Voltage	I _{OUT} =20mA	Refer to Dropout Voltage Table			
ΔV _{OUT} /ΔT _{opt}	Output Voltage Temperature Coefficient	V _{IN} =V _{OUT} +2.0V I _{OUT} =20mA -40°C ≤ T _{opt} ≤ 85°C		±100		ppm/°C
I _{lim}	Short Current Limit	V _{OUT} =0V		45		mA

VD

T_{opt}=25°C

Symbol	Item	Conditions	Min.	Typ.	Max.	Unit
-V _{DET}	Detector Threshold		×0.975		×1.025	V
V _{HYS}	Detector Threshold Hysteresis		-V _{DET} ×0.03	-V _{DET} ×0.05	-V _{DET} ×0.07	V
I _{OUT2}	Output Current (Driver Output Pin)	Refer to Test Conditions for Output Current Table	0.17			mA
V _{DDL}	Minimum Operating Voltage	*Note 1		0.9	1.2	V
Δ-V _{DET} /ΔT _{opt}	Detector Threshold Temperature Coefficient	-40°C ≤ T _{opt} ≤ 85°C		±100		ppm/°C
t _{PLH}	Output Delay Time	C _D =4.7nF, *Note 2	20	30	50	ms
	Release Margin	V _{OUT} -0.2-(-V _{DET})-V _{HYS}	50			mV

Note 1) This item means V_{DD} Voltage when Output Voltage is equal or less than 0.1V.
(Pull-up Resistor=470kΩ, Pull up Voltage=5V)

Note 2) V_{DET} pin is pulled up to V_{DD} via 470kΩ. t_{PLH} means time interval from rising edge of V_{DD} from (-V_{DET})-2.0V to (-V_{DET})+2.0V to the point of Output Voltage being 80% of pull-up voltage.

- Output Current (T_{opt}=25°C)

Output Voltage V _{OUT} (V)	Output Current (mA)	
	Min.	Typ.
2.1V ≤ V _{OUT} ≤ 2.9V	90	140
3.0V ≤ V _{OUT} ≤ 4.0V	120	170
4.1V ≤ V _{OUT} ≤ 14.0V	150	200

- Load Regulation (T_{opt}=25°C)

Output Voltage V _{OUT} (V)	Load Regulation (mV)	
	Typ.	Max.
2.1V ≤ V _{OUT} ≤ 3.0V	15	35
3.1V ≤ V _{OUT} ≤ 5.0V	25	45
5.1V ≤ V _{OUT} ≤ 10.0V	40	65
10.1V ≤ V _{OUT} ≤ 14.0V	50	80

- Dropout Voltage (T_{opt}=25°C)

Output Voltage V _{OUT} (V)	Dropout Voltage (V)	
	Typ.	Max.
2.1V ≤ V _{OUT} ≤ 2.4V	0.40	0.60
2.5V ≤ V _{OUT} ≤ 3.0V	0.30	0.40
3.1V ≤ V _{OUT} ≤ 7.0V	0.25	0.35
7.1V ≤ V _{OUT} ≤ 10.0V	0.27	0.45
10.1V ≤ V _{OUT} ≤ 14.0V	0.30	0.50

- Test Conditions for Output Current

Detector Threshold Voltage -V _{DET} (V)	Conditions
2.1V ≤ (-V _{DET}) ≤ 15.0V	V _{IN} =2V, V _{DS} =0.05V
(-V _{DET})=2.0	V _{IN} =1.9V, V _{DS} =0.05V

RECOMMENDED OPERATING CONDITIONS (ELECTRICAL CHARACTERISTICS)

All of electronic equipment should be designed that the mounted semiconductor devices operate within the recommended operating conditions. The semiconductor devices cannot operate normally over the recommended operating conditions, even if when they are used over such conditions by momentary electronic noise or surge. And the semiconductor devices may receive serious damage when they continue to operate over the recommended operating conditions.

TEST CIRCUITS

• R1150HxxxA

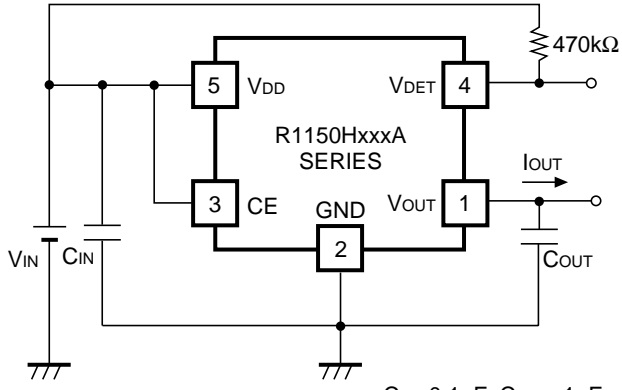

$C_{IN}=0.1\mu F, C_{OUT}=1\mu F$

Standard Test Circuit

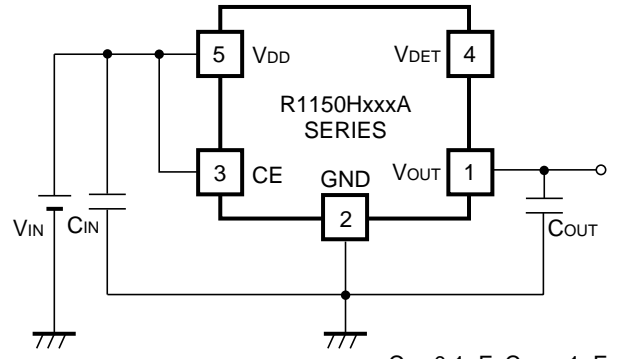

$C_{IN}=0.1\mu F, C_{OUT}=1\mu F$

Supply Current Test Circuit

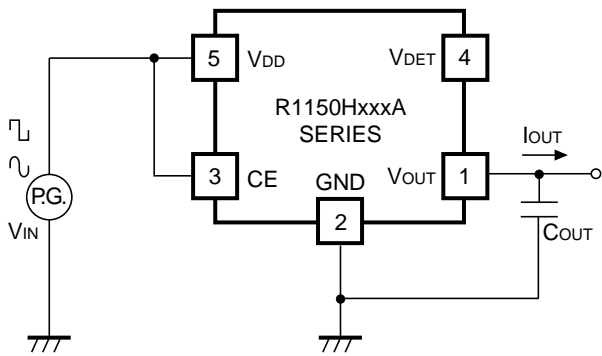

$C_{IN}=0.1\mu F, C_{OUT}=1\mu F$

**Input Transient Response/
Ripple Rejection Test Circuit**

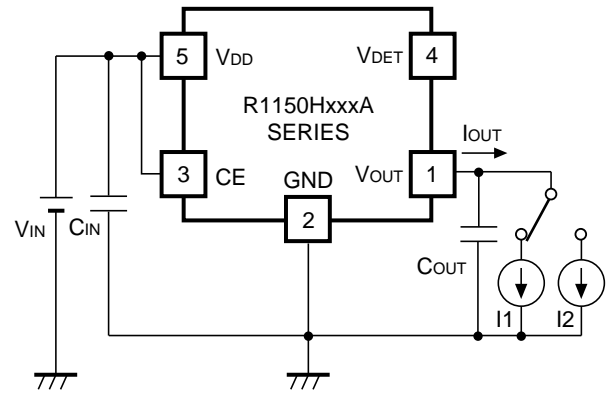

$C_{IN}=0.1\mu F, C_{OUT}=1\mu F$

Load Transient Response Test Circuit

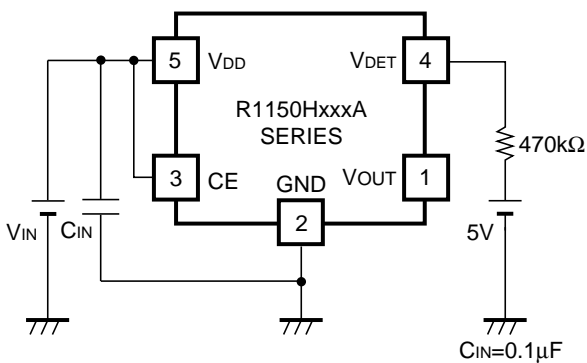

$C_{IN}=0.1\mu F$

Minimum Operating Voltage Test Circuit

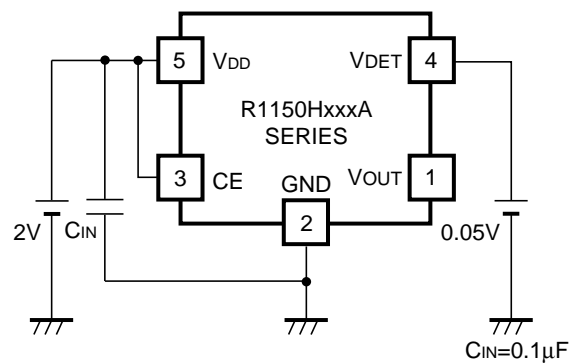

$C_{IN}=0.1\mu F$

VD Output Current Test Circuit

• R1150HxxxB

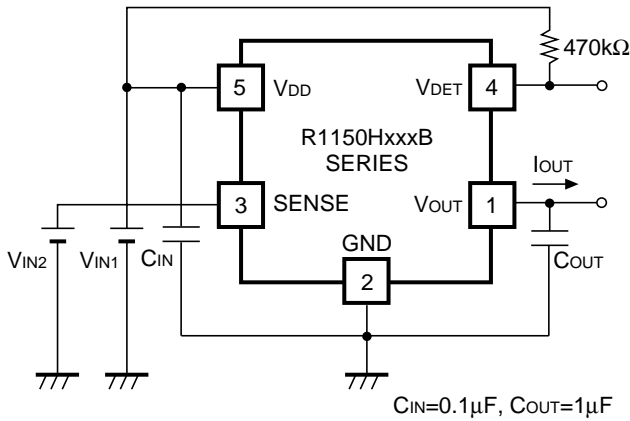

Standard Test Circuit

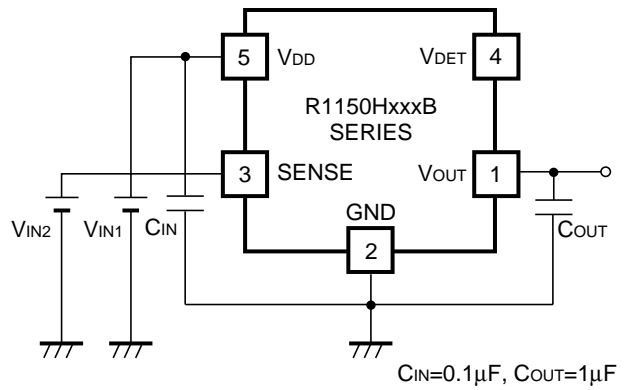

Supply Current Test Circuit

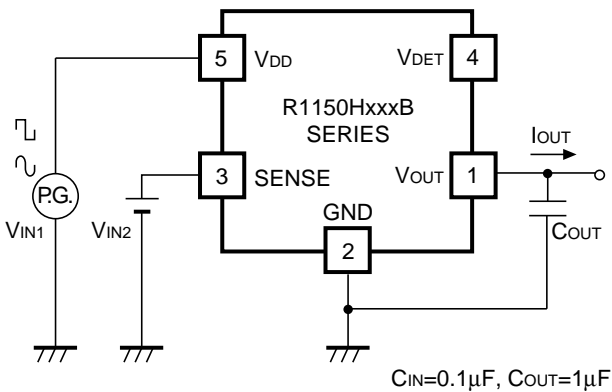

Input Transient Response/
Ripple Rejection Test Circuit

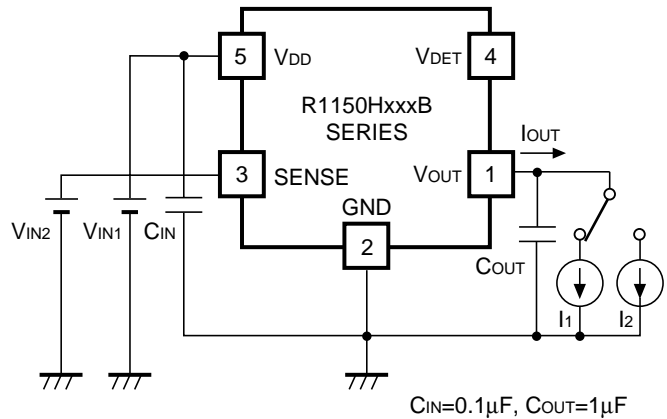

Load Transient Response Test Circuit

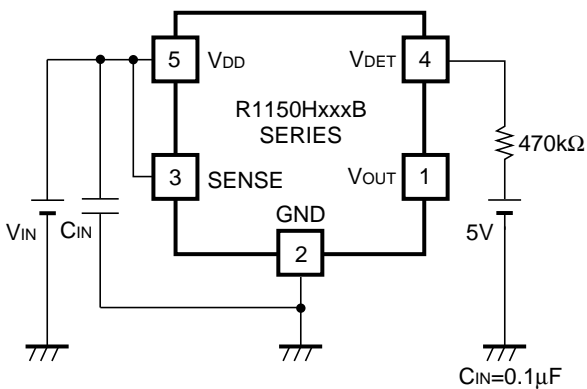

VDET Minimum Operating Voltage Test Circuit

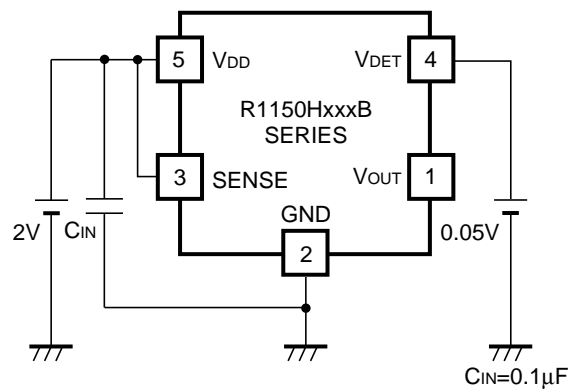

VD Output Current Test Circuit

• R1150HxxxC/D

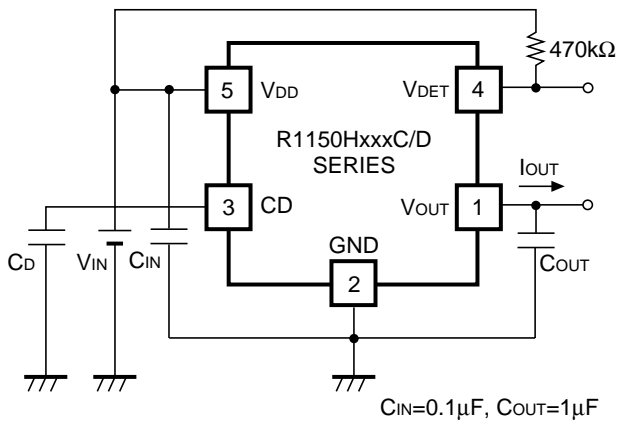

Standard Test Circuit

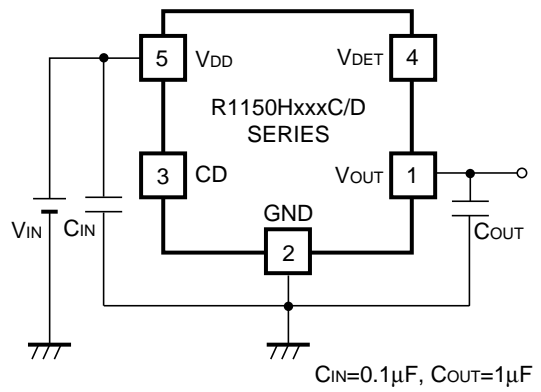

Supply Current Test Circuit

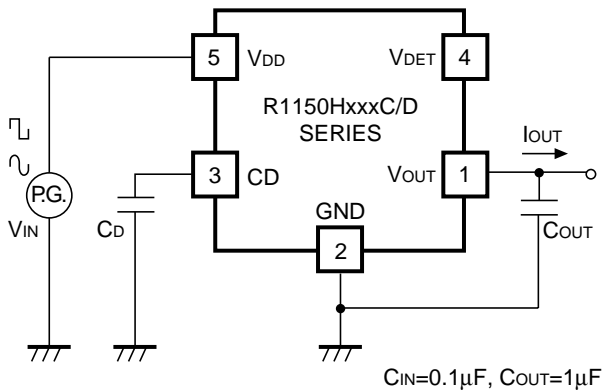

Input Transient Response/
Ripple Rejection Test Circuit

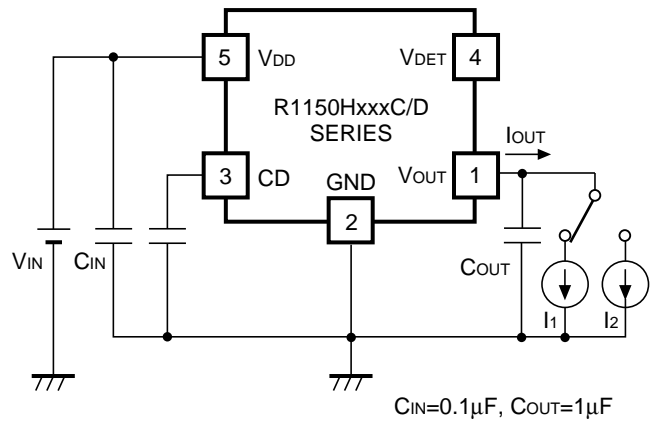

Load Transient Response Test Circuit

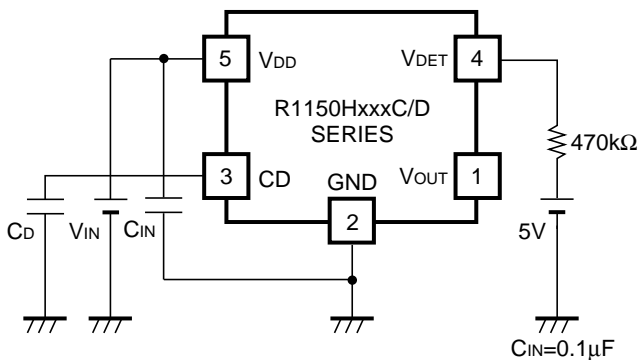

V_{DET} Minimum Operating Voltage Test Circuit

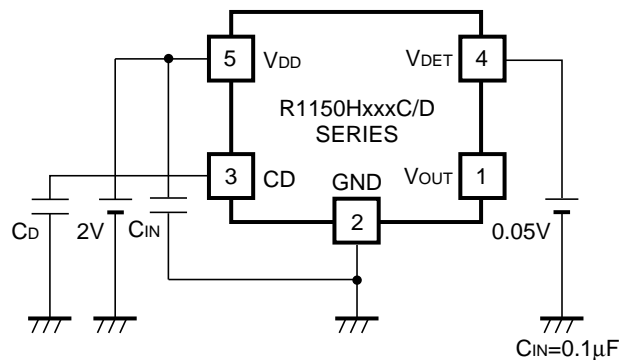

VD Output Current Test Circuit

TYPICAL CHARACTERISTICS

1) Output Voltage vs. Temperature

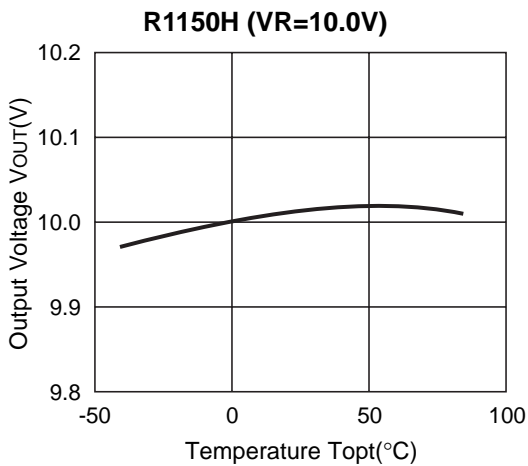
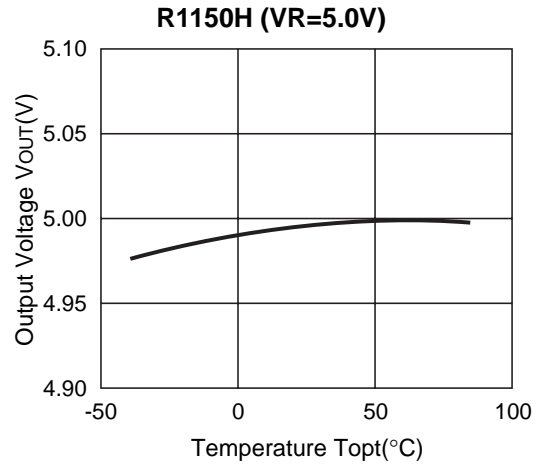
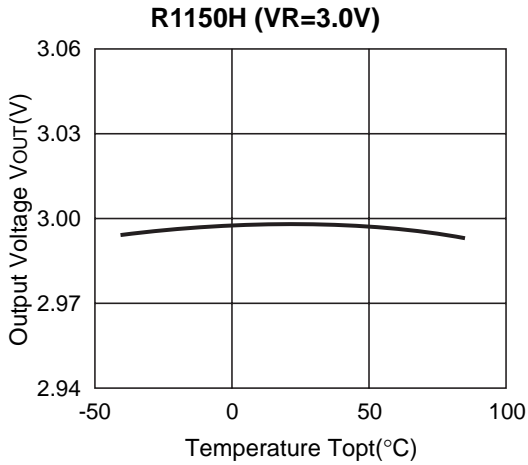

2) Output Voltage vs. Input Voltage

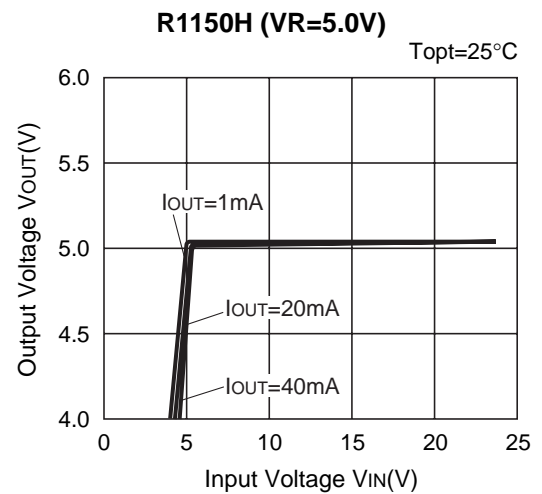
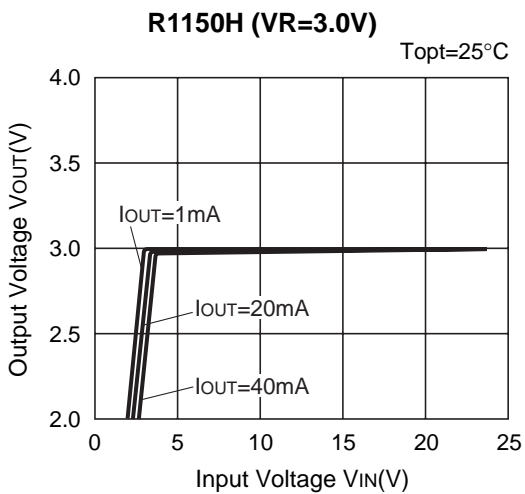

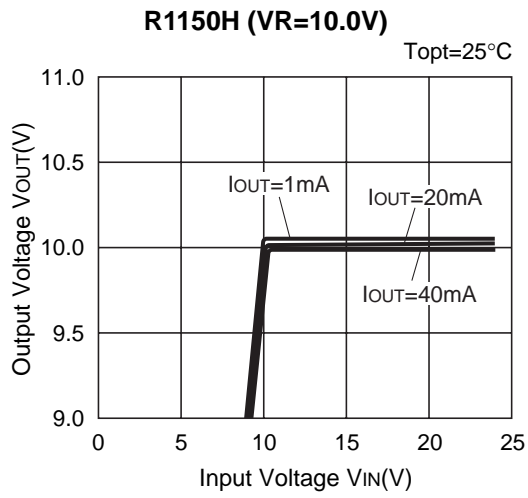

3) Output Voltage vs. Output Current

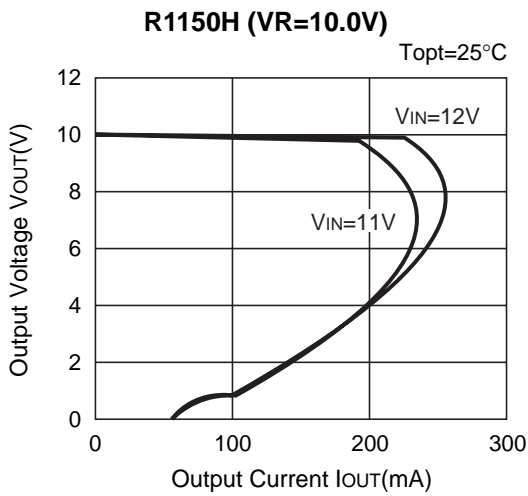
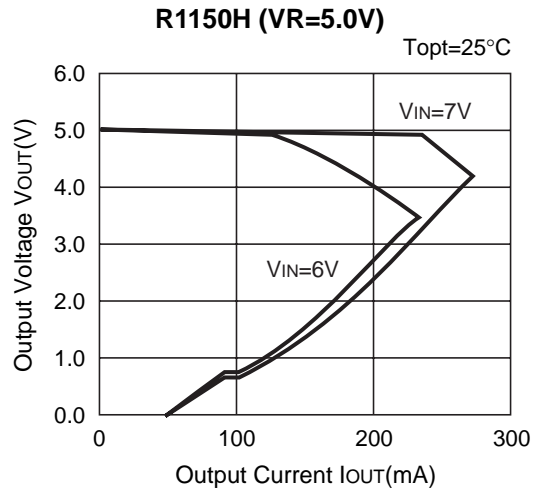
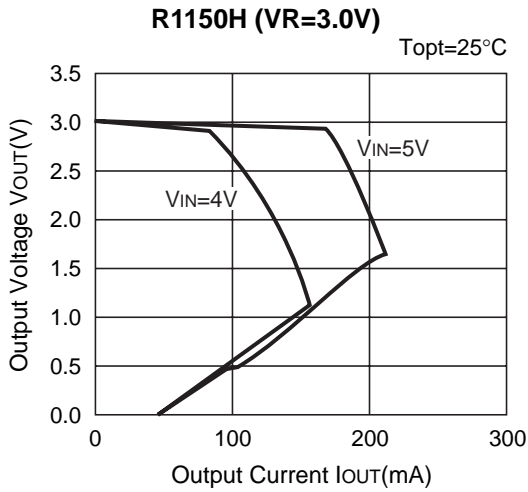

4) Dropout Voltage vs. Output Current

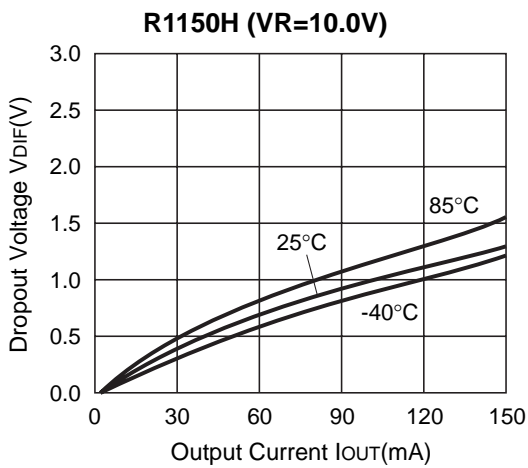
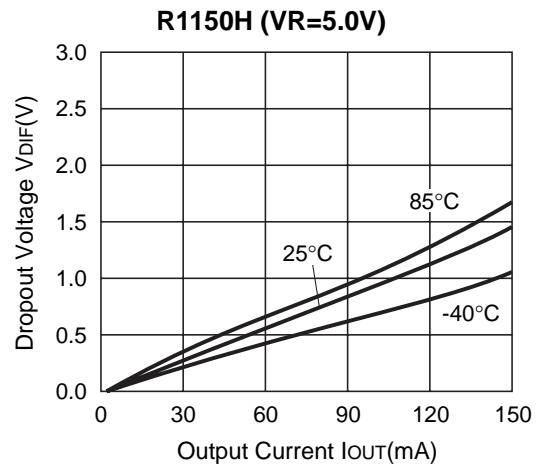
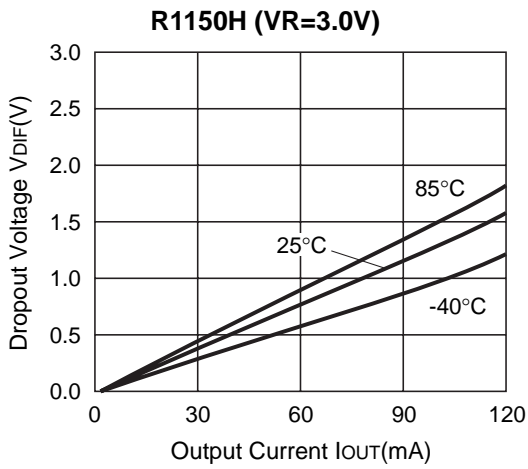

5) Supply Current vs. Input Voltage

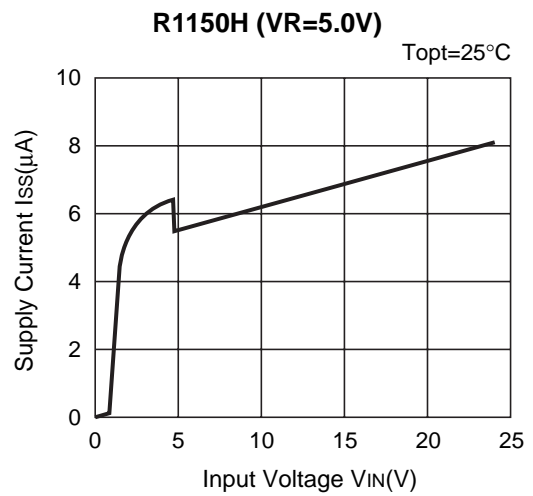
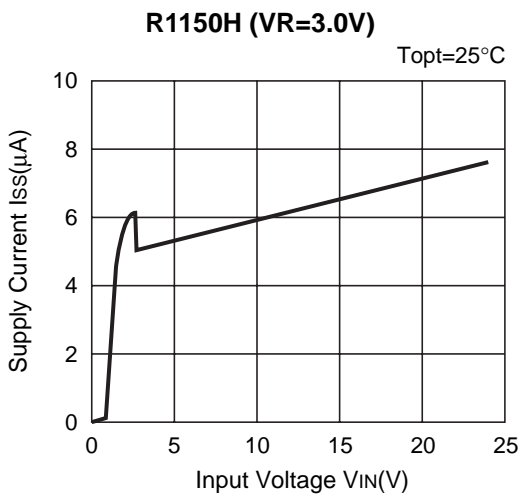

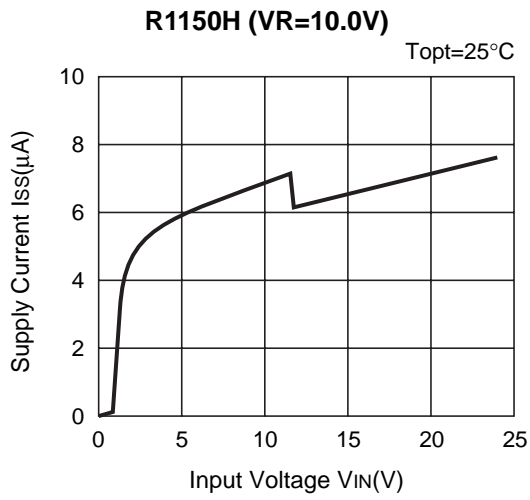

6) Supply Current vs. Temperature

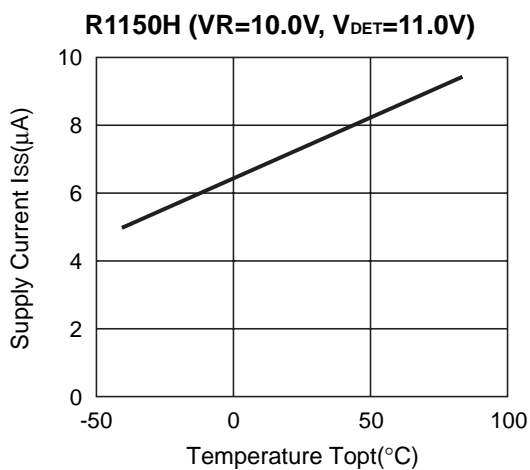
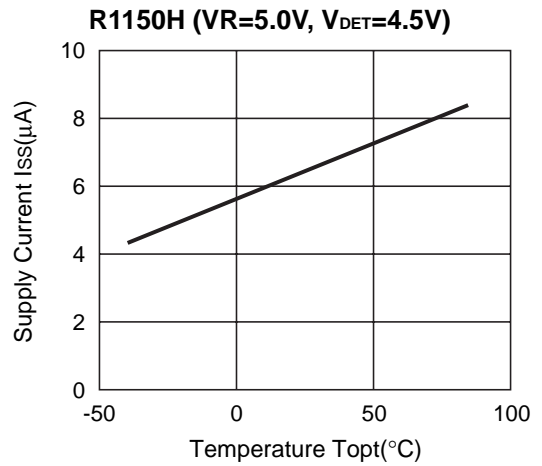
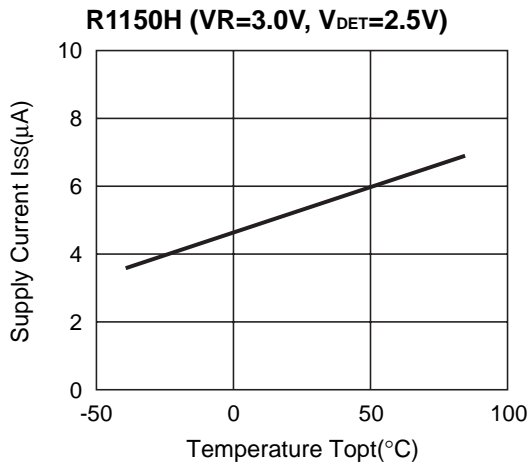

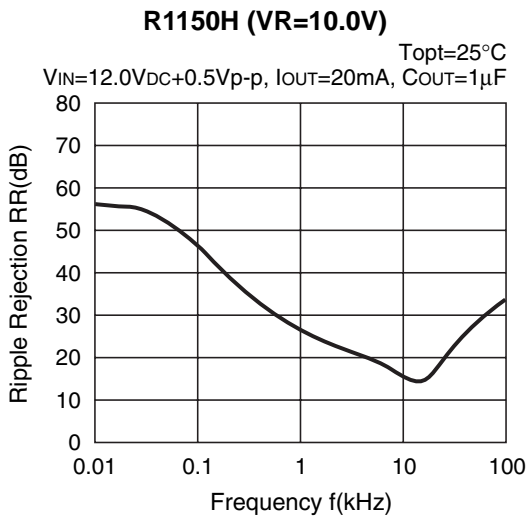
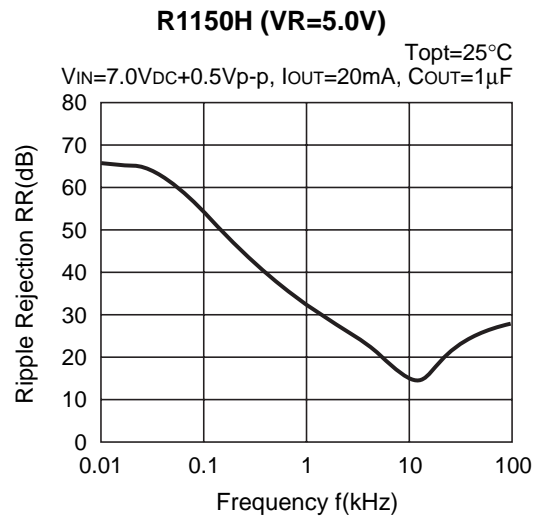
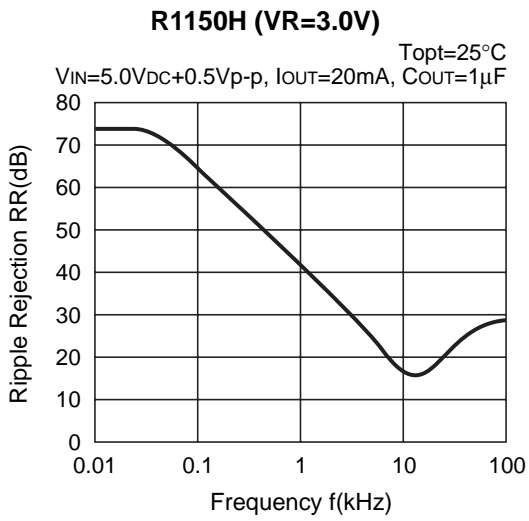
7) Ripple Rejection vs. Frequency

8) Input Transient Response

R1150H (VR=3.0V)

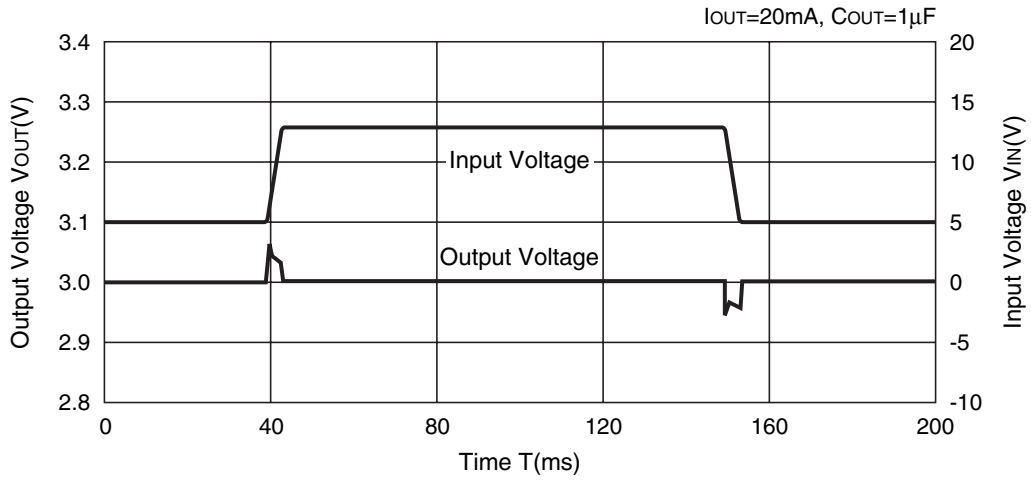

R1150H (VR=5.0V)

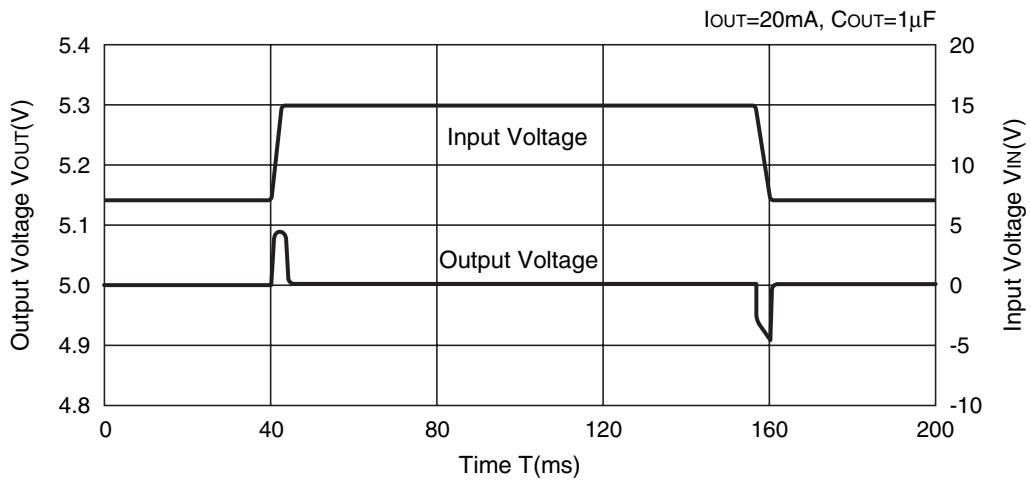

R1150H (VR=10.0V)

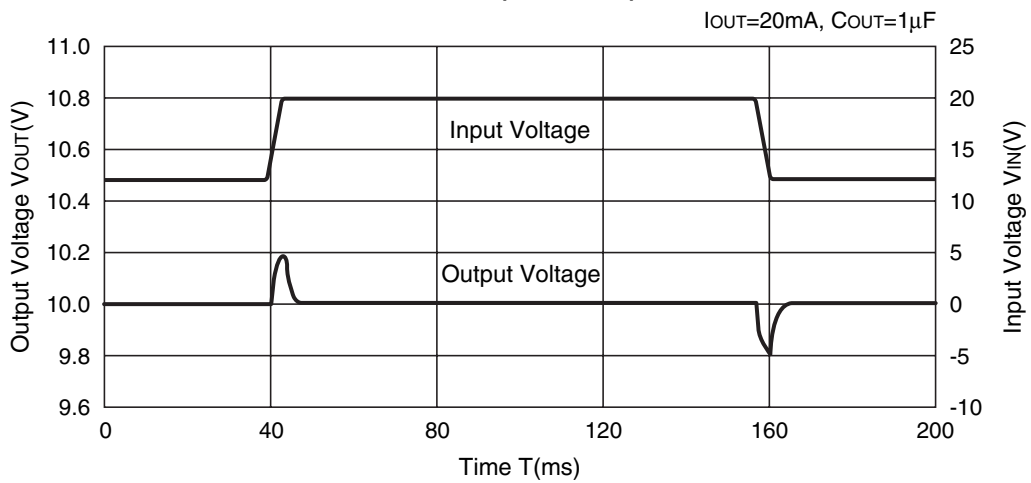

9) Load Transient Response

R1150H (VR=3.0V)

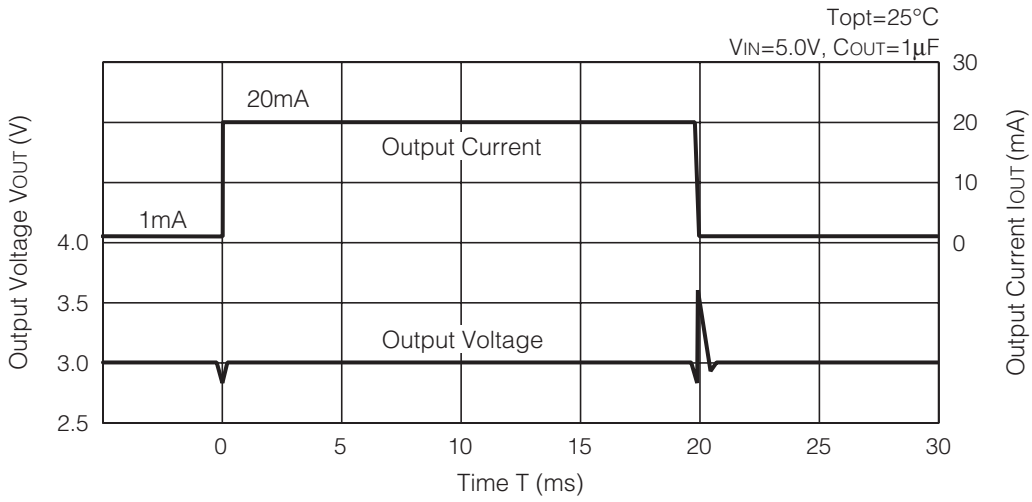

R1150H (VR=5.0V)

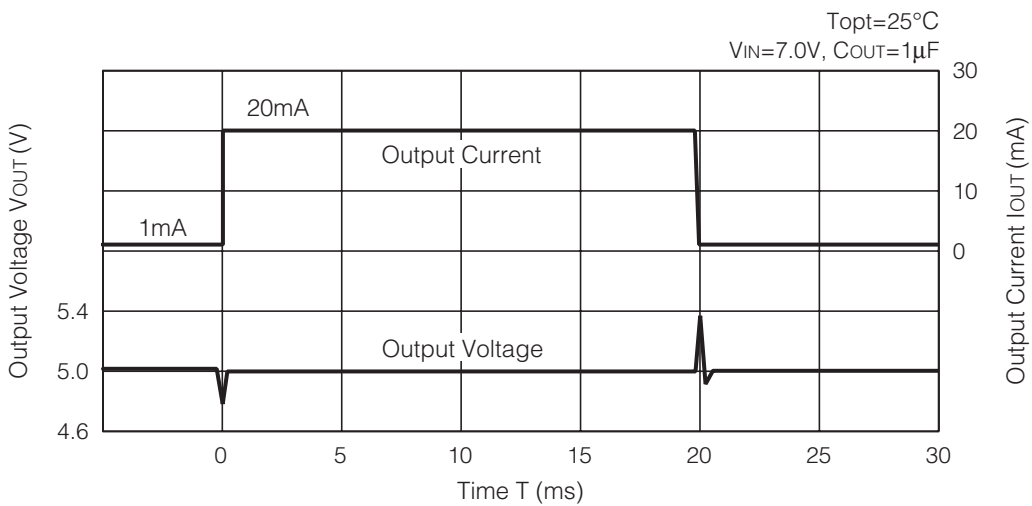

R1150H (VR=10.0V)

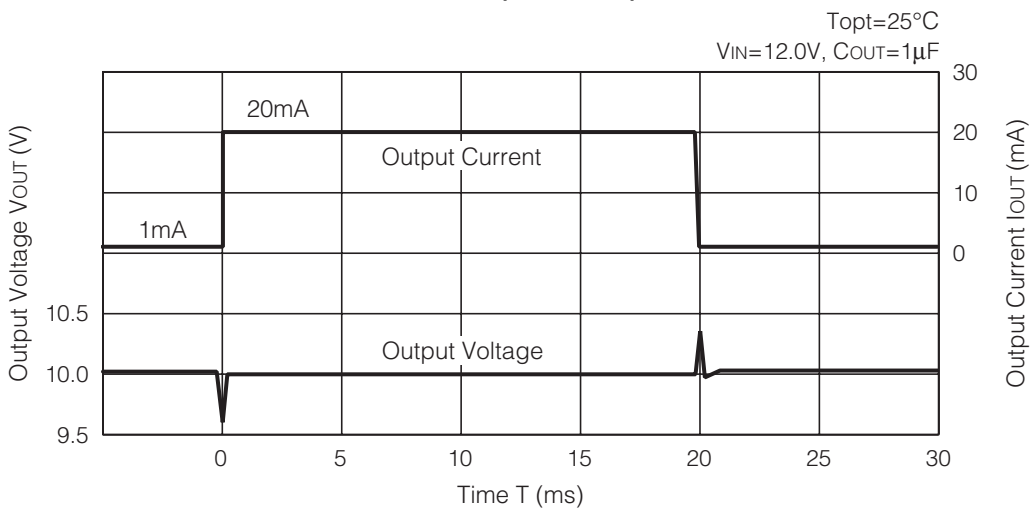

10) Detector Threshold vs. Temperature

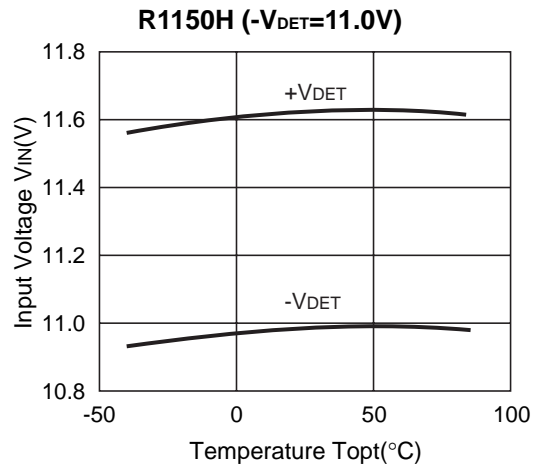
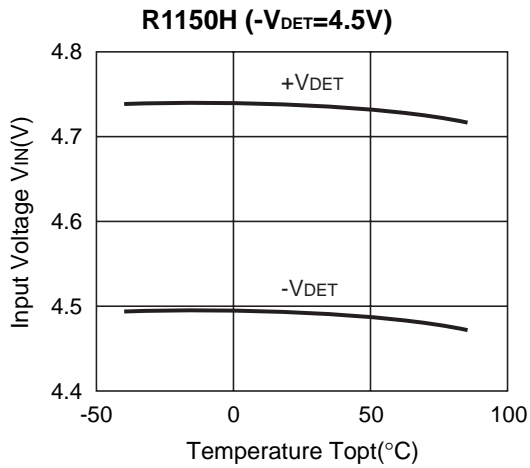

11) Detector Threshold vs. Input Voltage

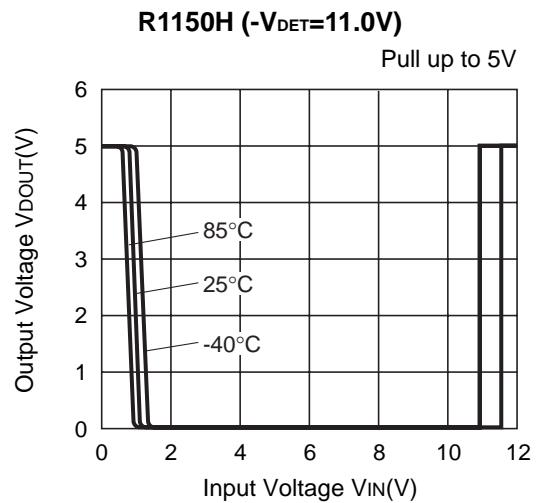
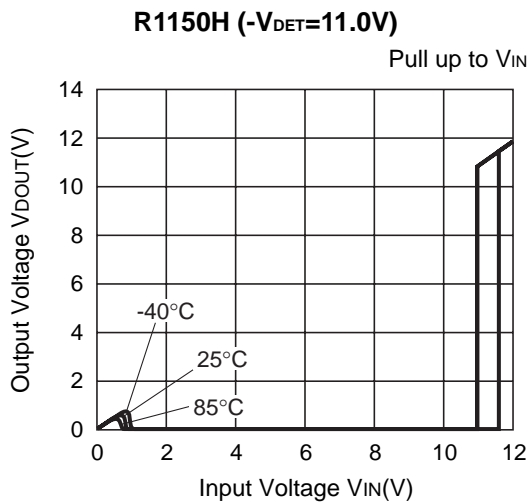
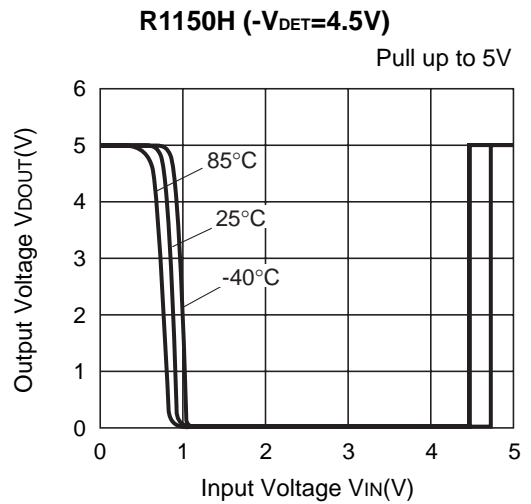
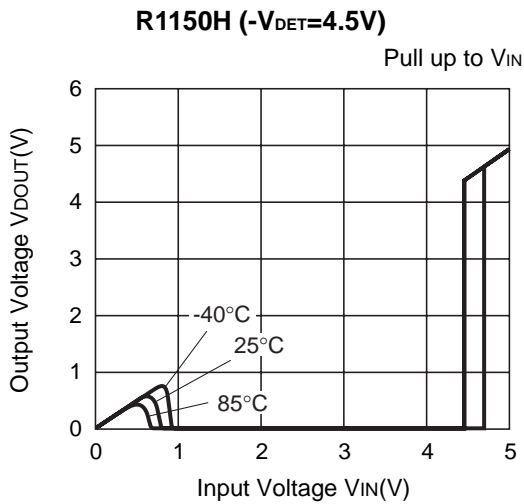

12) Nch Driver Output Current vs. V_{DS}

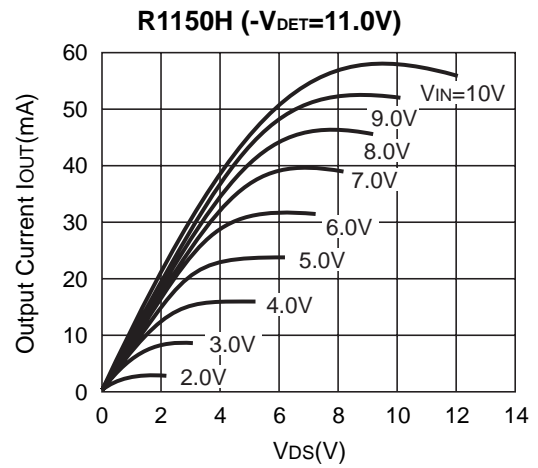
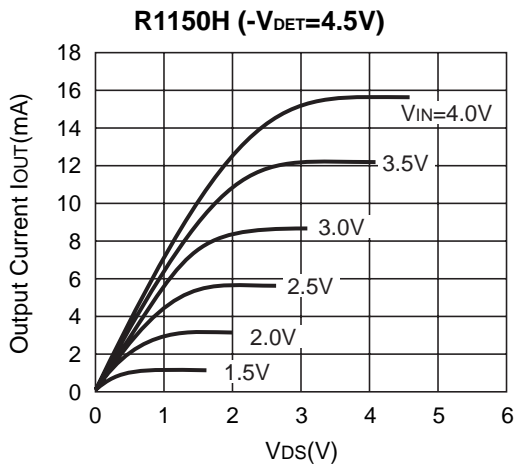

13) Nch Driver Output Current vs. Input Voltage

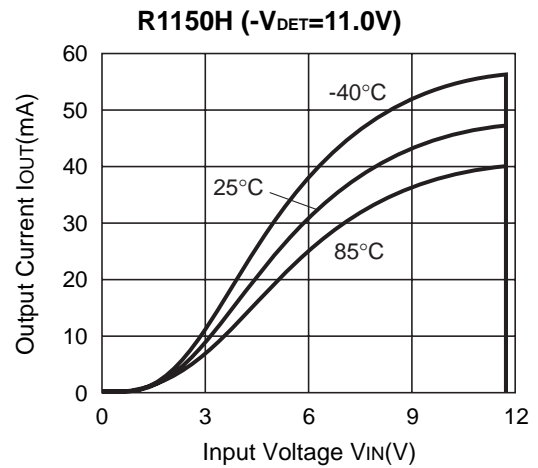
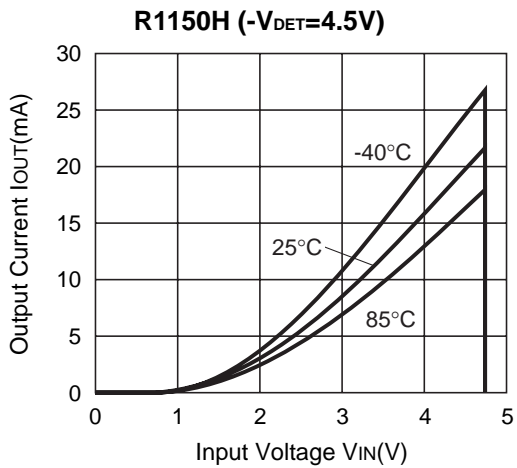

14) Detector Output Delay Time vs. Temperature

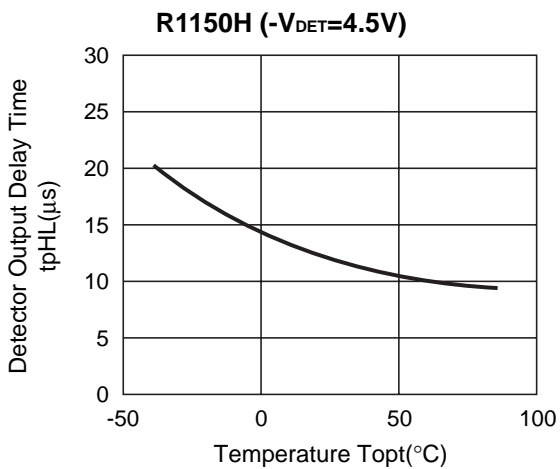

15) Thermal Shutdown Temperature vs. Output Voltage

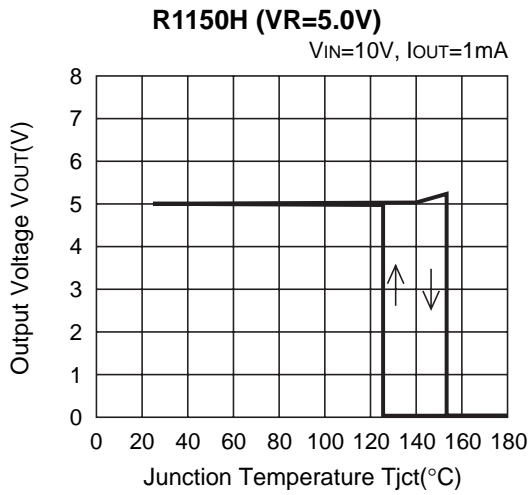

16) Output Delay Time vs. Temperature

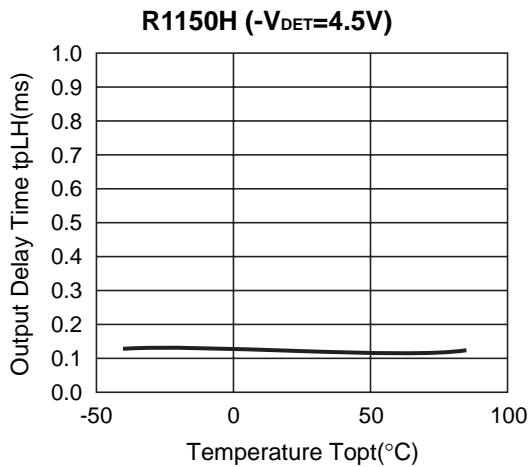

17) C_D pin Threshold Voltage vs. Temperature

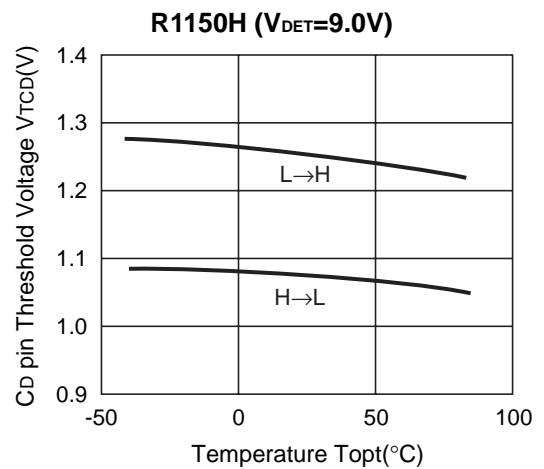
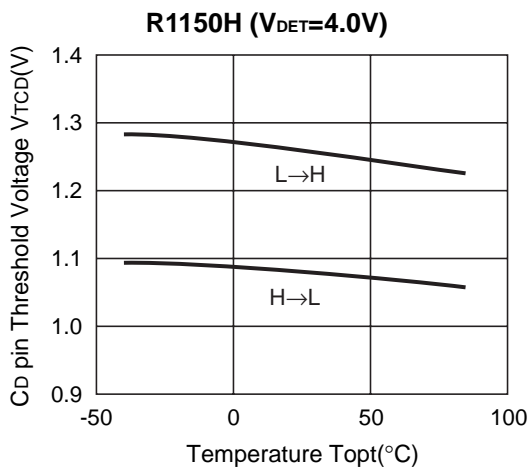

18) C_D pin Sink Current vs. Input Voltage

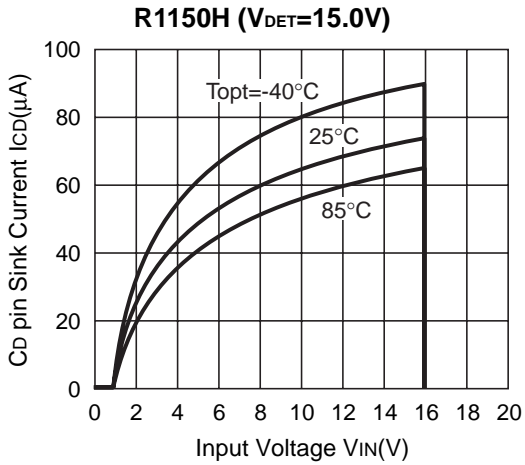
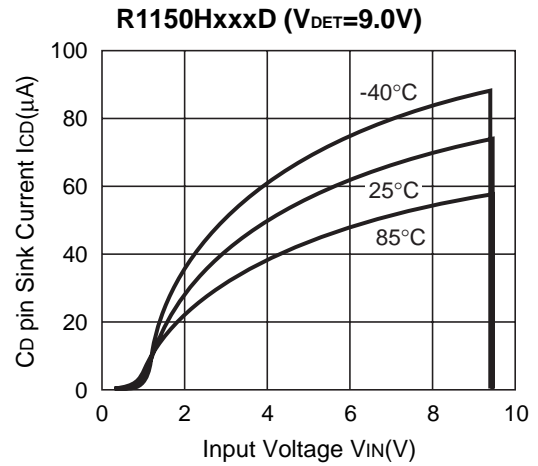
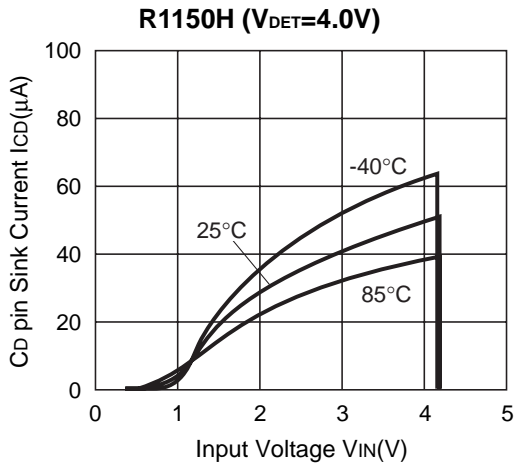

19) C_D pin Sink Current vs. V_{DS}

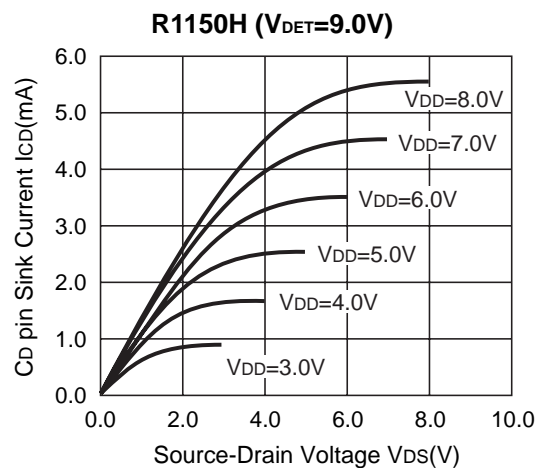
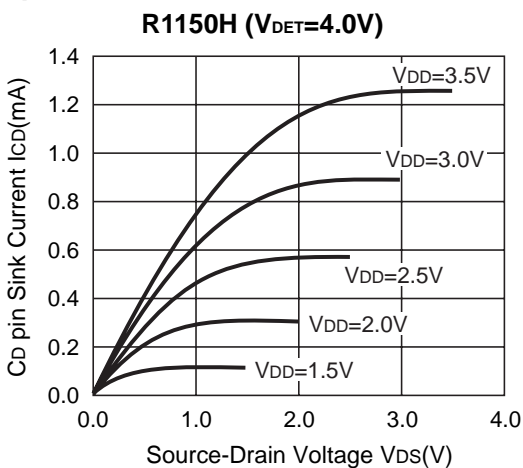

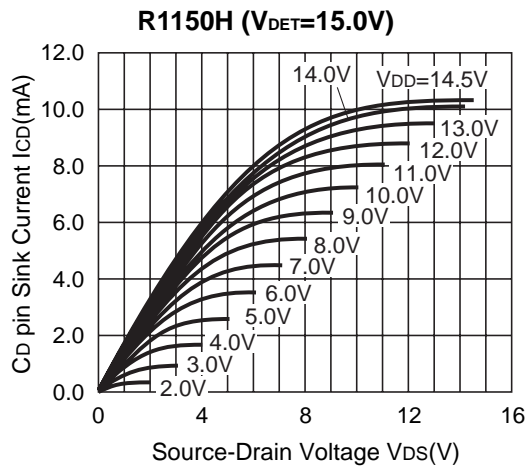

20) Output Delay Time vs. External Capacitance

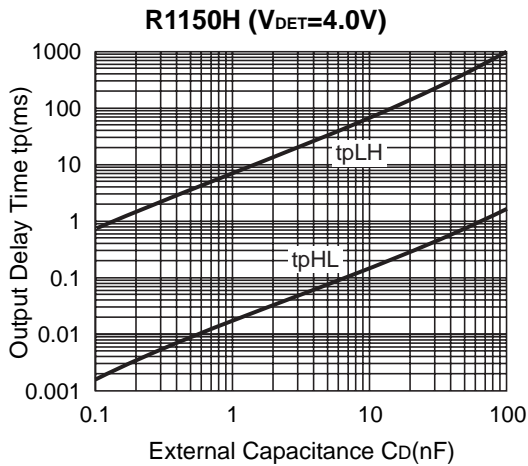

21) t_{pLH} delay vs. Temperature

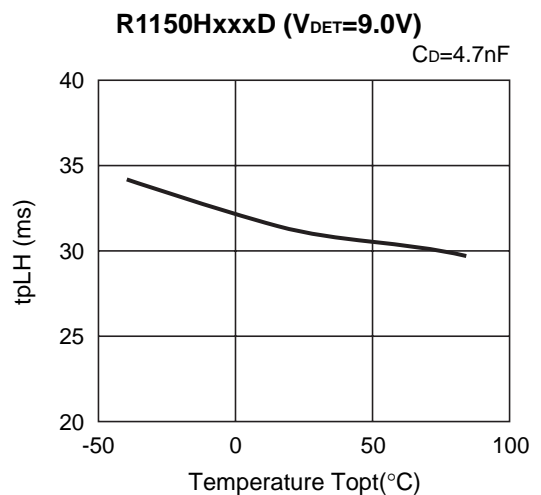
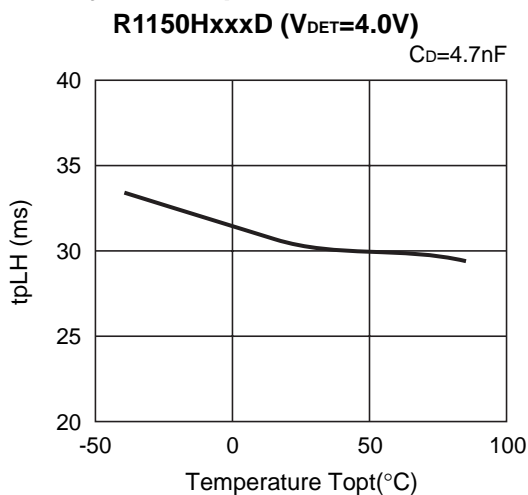

TYPICAL APPLICATIONS

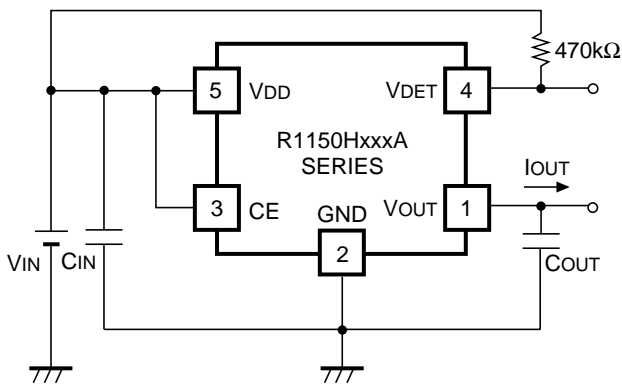

R1150HxxxA

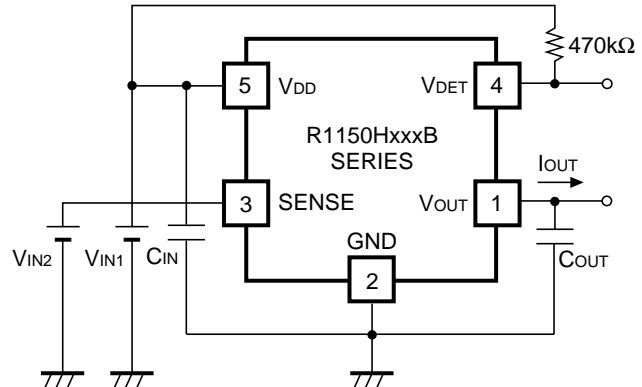

R1150HxxxB

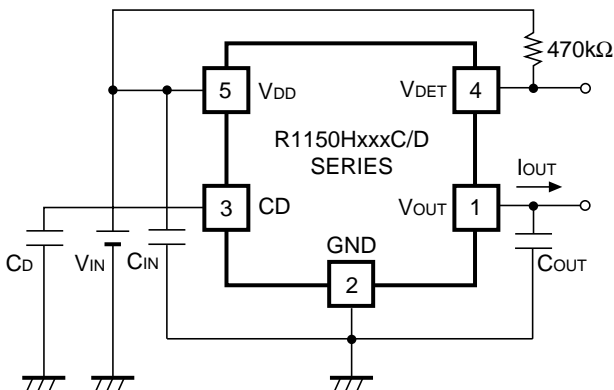

R1150HxxxC

TECHNICAL NOTES

Phase Compensation

Phase Compensation of the R1150H Series has been made internally for stable operation even though the load current would vary. Therefore, without the capacitors, C_{IN} and C_{OUT} , Output Voltage is regulated, but for more stable operation, use $0.1\mu\text{F}$ or more capacitors as C_{IN} and C_{OUT} . Wiring should be made as short as possible.

PCB layout

Current flows into wiring for V_{DD} or GND, thus, if the impedance of the wiring is rather high, it may cause of making noise or unstable operation, thus width and pattern should be enough wide to avoid such problems. Connect the capacitor, C_{IN} between V_{DD} pin and GND pin as close as possible.

About the output voltage and the detector threshold setting (In case of R1150HxxxD)

When the value difference between release voltage of voltage detector and the output voltage of voltage regulator is little, the release function may not operate after detective, due to change the output voltage of voltage detector. Pay attention for setting of the release voltage.

Refer to the following formula for setting the voltage of output and detective value.

$$(V_{OUT} \times 0.975) - (-V_{DET} \times 1.10) > 0.2$$

Thermal Shutdown

Thermal shutdown function is included in the R1150HxxxA/B/C/D Series, when the junction temperature is equal or more than +150°C (Typ.), the operation of regulator would stop. After that, when the junction temperature is equal or less than +120°C (Typ.), the operation of regulator would restart. Unless the cause of rising temperature would remove, the regulator repeats on and off, and output waveform would be like consecutive pulses.

Chip Enable Circuit

Do not make voltage level of chip enable pin keep floating level, or in between V_{IH} and V_{IL} . Unless otherwise, Output voltage would be unstable or indefinite, or unexpected current would flow internally.

Output Delay Time for Release V_{DET}

In the R1150Hxx1C/D can set an output delay time for release voltage detector with connecting a capacitor to C_D pin. When an input voltage (in the case of R1150Hxx1C) or an output voltage (in the case of R1150Hxx1D) surpasses the release voltage of its voltage detector ($+V_{DET}$), the capacitor which is connected to C_D pin is started to be charged, as a result, C_D pin voltage rises. When the C_D pin voltage surpasses C_D pin threshold voltage, the output voltage of the voltage detector outputs "H".

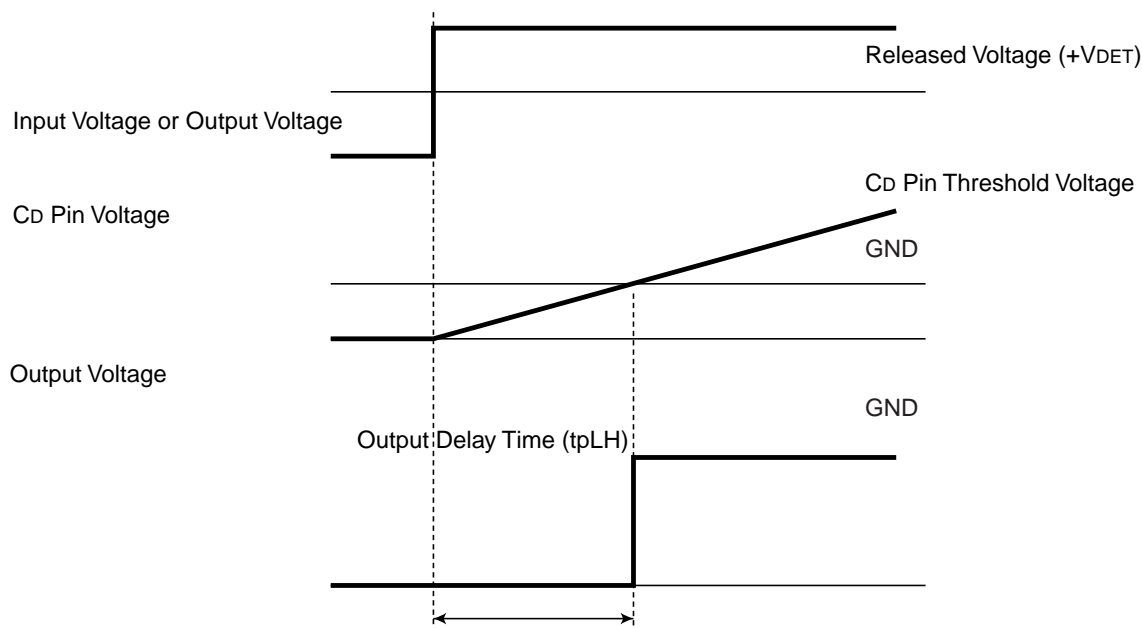

Output delay time for release voltage detector can be calculated with the next formula:

$$t_{PLH} = 1.25/200 \times 10^9 \times C_D \text{ (sec)}$$

Input Transient Response

If the input transient speed is equal or faster than 80mV/ μ s and the transient level difference is equal or more than 1.5V, the output response may be extremely worse than normal operation. In that case, add a capacitor between V_{IN} and GND, and make the transient speed of V_{IN} slower than 80mV/ μ s.



1. The products and the product specifications described in this document are subject to change or discontinuation of production without notice for reasons such as improvement. Therefore, before deciding to use the products, please refer to Ricoh sales representatives for the latest information thereon.
2. The materials in this document may not be copied or otherwise reproduced in whole or in part without prior written consent of Ricoh.
3. Please be sure to take any necessary formalities under relevant laws or regulations before exporting or otherwise taking out of your country the products or the technical information described herein.
4. The technical information described in this document shows typical characteristics of and example application circuits for the products. The release of such information is not to be construed as a warranty of or a grant of license under Ricoh's or any third party's intellectual property rights or any other rights.
5. The products listed in this document are intended and designed for use as general electronic components in standard applications (office equipment, telecommunication equipment, measuring instruments, consumer electronic products, amusement equipment etc.). Those customers intending to use a product in an application requiring extreme quality and reliability, for example, in a highly specific application where the failure or misoperation of the product could result in human injury or death (aircraft, spacevehicle, nuclear reactor control system, traffic control system, automotive and transportation equipment, combustion equipment, safety devices, life support system etc.) should first contact us.
6. We are making our continuous effort to improve the quality and reliability of our products, but semiconductor products are likely to fail with certain probability. In order to prevent any injury to persons or damages to property resulting from such failure, customers should be careful enough to incorporate safety measures in their design, such as redundancy feature, firecontainment feature and fail-safe feature. We do not assume any liability or responsibility for any loss or damage arising from misuse or inappropriate use of the products.
7. Anti-radiation design is not implemented in the products described in this document.
8. Please contact Ricoh sales representatives should you have any questions or comments concerning the products or the technical information.

RICOH COMPANY., LTD. Electronic Devices Company



■ Ricoh presented with the Japan Management Quality Award for 1999.
Ricoh continually strives to promote customer satisfaction, and shares the achievements of its management quality improvement program with people and society.



■ Ricoh awarded ISO 14001 certification.
The Ricoh Group was awarded ISO 14001 certification, which is an international standard for environmental management systems, at both its domestic and overseas production facilities. Our current aim is to obtain ISO 14001 certification for all of our business offices.

<http://www.ricoh.com/LSI/>

RICOH COMPANY, LTD. Electronic Devices Company

● **Shin-Yokohama office (International Sales)**
3-2-3, Shin-Yokohama, Kohoku-ku, Yokohama City, Kanagawa 222-8530, Japan
Phone: +81-45-477-1697 Fax: +81-45-477-1698

RICOH EUROPE (NETHERLANDS) B.V.

● **Semiconductor Support Centre**
Prof. W.H.Keesomlaan 1, 1183 DL Amstelveen, The Netherlands
P.O.Box 114, 1180 AC Amstelveen
Phone: +31-20-5474-309 Fax: +31-20-5474-791

RICOH ELECTRONIC DEVICES KOREA Co., Ltd.

11 floor, Haesung 1 building, 942, Daechidong, Gangnamgu, Seoul, Korea
Phone: +82-2-2135-5700 Fax: +82-2-2135-5705

RICOH ELECTRONIC DEVICES SHANGHAI Co., Ltd.

Room403, No.2 Building, 690#Bi Bo Road, Pu Dong New district, Shanghai 201203,
People's Republic of China
Phone: +86-21-5027-3200 Fax: +86-21-5027-3299

RICOH COMPANY, LTD. Electronic Devices Company

● **Taipei office**
Room109, 10F-1, No.51, Hengyang Rd., Taipei City, Taiwan (R.O.C.)
Phone: +886-2-2313-1621/1622 Fax: +886-2-2313-1623



Ricoh completed the organization of the Lead-free production for all of our products. After Apr. 1, 2006, we will ship out the lead free products only. Thus, all products that will be shipped from now on comply with RoHS Directive.