

# KPS MIL Series, SMPS Stacked Capacitors, MIL-PRF-49470, DSCC 87106, 50VDC–500VDC (Commercial, Military, & Space Grades)

**KEMET**  
CHARGED:

## Overview

KEMET Power Solutions (KPS) MIL Series ceramic stacked capacitors are available in commercial, military and space grades and are well suited for standard and high reliability switch mode power supply (SMPS) and pulse energy applications. Qualified under performance specification MIL-PRF-49470, our military and space grade products meet or exceed the requirements outlined by DSCC (Defense Supply Center, Columbus) and are available in both B (standard reliability) & T (high reliability) product levels. MIL-PRF-49470 was developed as part of a cooperative effort between the U.S. Military, NASA and SMPS suppliers to produce a robust replacement to cancelled DSCC Drawing 87106.

The KPS MIL Series is constructed using large chip multilayer ceramic capacitors (MLCCs), horizontally stacked and secured to a lead-frame termination system using a high melting point (HMP) solder alloy. The lead frame isolates the MLCCs from the

printed circuit board (PCB) while establishing a parallel circuit configuration. Mechanically isolating the capacitors from the PCB improves mechanical and thermal stress performance, while the parallel circuit configuration allows for bulk capacitance in the same or smaller design footprint.

Available in BX, BR, BQ, and X7R dielectrics, these devices are available in encapsulated and unencapsulated styles in both surface mountable and through-hole configurations. Their low Equivalent Series Resistance (ESR) and Equivalent Series Inductance (ESL) make them ideally suited for input and output filtering of power supply as well as snubber applications. The encapsulated styles are primarily used where increased mechanical and environmental protection is required, such as in avionics systems.

## Benefits

- -55°C to +125°C operating temperature range
- High frequency performance
- Bulk capacitance in a reduced footprint
- MIL-PRF-49470 QPL
- Military Case Codes 3, 4 and 5
- Space Grade available (“T” Level)
- DSCC approved (87106)
- Commercial/Industrial Grade available
- Customer specific requirements available
- Low ESR and ESL
- High thermal stability
- High ripple current capability
- Higher reliability than aluminum electrolytic or tantalum
- Available encapsulated or unencapsulated

## Applications

- Military
- Space
- Industrial
- Input and output filtering on power supplies – often found on “capacitor banks”
- Snubber circuits
- Radar filtering (28V/microwave burst)

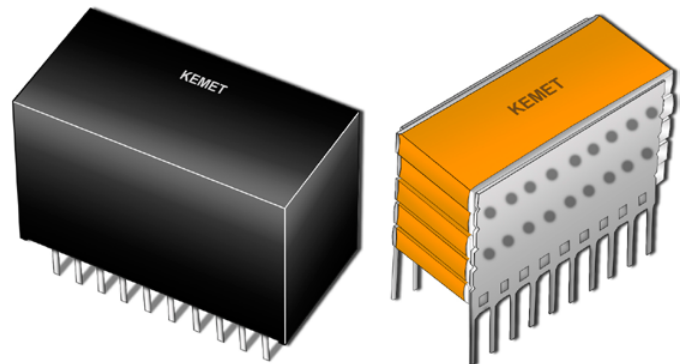

## MIL-PRF-49470 Ordering Information

M49470	R	01	474	K	C	N
Performance Specification Indicating MIL-PRF-49470 <sup>1</sup>	Dielectric Classification/Characteristic <sup>2</sup>	Performance Specification Sheet Number (Indicating MIL-PRF-49470/1) <sup>3</sup>	Capacitance Code (pF)	Capacitance Tolerance	Rated Voltage (DC)	Lead Configuration <sup>4</sup>
M49470 = B level T49470 = T level  A "T" prefix is used in place of the "M" for T level product.	Q = BQ R = BR X = BX	01 = Unencapsulated 02 = Encapsulated	2 Sig. Digits + Number of Zeros	J = ±5% K = ±10% M = ±20%	A = 50V B = 100V C = 200V E = 500V	N = Straight Pin L = Formed "L" M = Formed "L" J = Formed "J" K = Formed "J"

<sup>1</sup> Indicates performance and reliability requirements. "B" level represents standard reliability."T" level represents high reliability.

<sup>1</sup> Please refer to performance specification sheet MIL-PRF-49470 for details regarding test levels. The latest revision of the specification sheet is available through DSCC.

<sup>1,3</sup> Test level option "T" is not available on encapsulated stacked devices (i.e. MIL-PRF-49470/2).

<sup>2</sup> Dielectric classification and characteristic details are outlined in the "Electrical Parameters" section of this document.

<sup>4</sup> Lead configuration and dimension details are outlined in the "Dimensions" section of this document.

## KPS MIL Series, SMPS Stacks Ordering Information

(Do not use this ordering code if a QPL MIL-SPEC part type is required. Please order using MIL-SPEC ordering code. Details regarding MIL-PRF-49470 QPL ordering information is outlined above.)

L1	R	N	30	C	106	K	S	12	
Product Family <sup>1</sup>	Dielectric Classification/Characteristic <sup>2</sup>	Lead Configuration <sup>3</sup>	Case Size / Case Code (CC)	Rated Voltage (DC)	Capacitance Code (pF)	Capacitance Tolerance	Testing Option <sup>4</sup>	Maximum Height Dimension (in.) <sup>5</sup>	
L1 = Unencapsulated L2 = Encapsulated	Q = BQ R = BR X = BX W = X7R	N = Straight L = Formed "L" M = Formed "L" J = Formed "J" K = Formed "J"	30 = CC 3 40 = CC 4 50 = CC 5	3 = 25V 5 = 50V 1 = 100V 2 = 200V C = 500V B = 630V D = 1000V	2 Sig. Digits + Number of Zeros	J = ±5% K = ±10% M = ±20%	B = M49470 "B" Level T = M49470 "T" Level C = DSCC87106 S = Commercial X = Non-Standard (Customer Specific Requirements)	Unencapsulated 12 = 0.12" 24 = 0.24" 36 = 0.36" 48 = 0.48" 65 = 0.65"	Encapsulated 27 = 0.27" 39 = 0.39" 53 = 0.53" 66 = 0.66" 80 = 0.80"

<sup>1, 4</sup> Test level option "T" is not available on encapsulated stacked devices, i.e., MIL-PRF-49470/2. If a QPL MIL-Spec part type is required, please order using the MIL-Spec ordering code.

<sup>2</sup> Dielectric classification and characteristic details are outlined in the "Electrical Parameters" section of this document.

<sup>3</sup> Lead configuration and dimension details are outlined in the "Dimensions" section of this document. Additional lead configurations may be available. Contact KEMET for details.

<sup>4</sup> Indicates performance and reliability requirements. Testing option details are outlined in the "Performance and Reliability" section of this document.

<sup>4</sup> Please refer to performance specification sheet MIL-PRF-49470 for additional details regarding test levels. The latest revision of the specification sheet is available through DSCC.

<sup>4</sup> DSCC Drawing 87106 was cancelled on 01/03/2005. MIL-PRF-49470 capacitors are preferred over DSCC Drawing 87106 capacitors.

<sup>5</sup> Maximum height dimensions are provided in product tables 1A, 1B, and 1C of this document

## Ordering Information Requirements per DSCC Drawing 87106

DSCC Drawing 87106 was cancelled on 01/03/2005. Customers can continue to order per 87106 requirements using the original DSCC ordering code, i.e., 87106-001. When available, MIL-PRF-49470 devices are preferred over DSCC Drawing 87106. The MIL-PRF-49470 military specification product provides additional quality assurance provisions that are not required by the DSCC drawing. These extra provisions create a more robust replacement.

## Construction

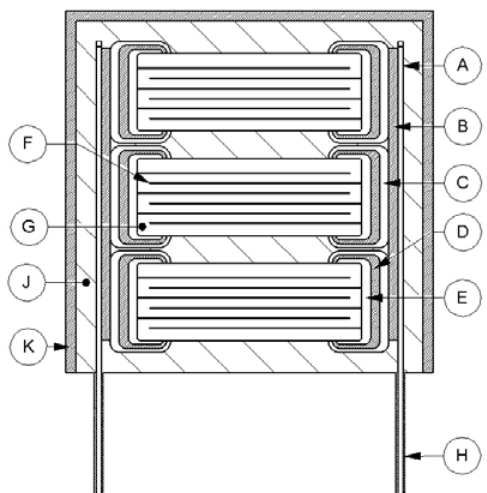

Note: Image is exaggerated in order to clearly identify all components of construction

Reference	Item	Material
A	Leadframe	Phosphor Bronze - Alloy 510
B	Leadframe Attach Solder	Sn10, Pb88, Ag2
C	Termination System <sup>1</sup>	SnPb (4% min.)
D		Ni
E		Ag
		Solderable Silver
F	Electrode	PdAg
G	Dielectric	BaTiO <sub>3</sub>
H	Lead Solder	Sn60, Pb40
J	Encapsulation <sup>2</sup>	Molding Compound
K		Diallyl-Phthalate (DAP)

<sup>1</sup> KEMET reserves the right to construct these devices using either of the termination systems outlined.

<sup>2</sup> Encapsulated product only, i.e., MIL-PRF-49470/2 and L2 product families.

## Unencapsulated (M49470/1 & L1) Product Dimensions – Inches (Millimeters)

Case Code	C Lead Spacing ±0.025 (0.635)	E Length ±0.010 (0.250)	D Width Min.	D Width Max.	A Height Max.	Seating Plane <sup>1</sup> ±0.010 (0.250)	Number of Leads per Side	Mounting Technique
3	0.450 (11.43)	0.500 (12.70)	0.950 (24.13)	1.075 (27.30)	Refer to tables 1A & 1C for specific maximum A dimension	0.055 (1.40)	10	Solder reflow only
4	0.400 (10.16)	0.440 (11.18)	0.350 (8.89)	0.425 (10.80)			4	
5	0.250 (6.35)	0.300 (7.62)	0.224 (5.69)	0.275 (6.98)			3	

<sup>1</sup> Only applies to lead style "N" (straight).

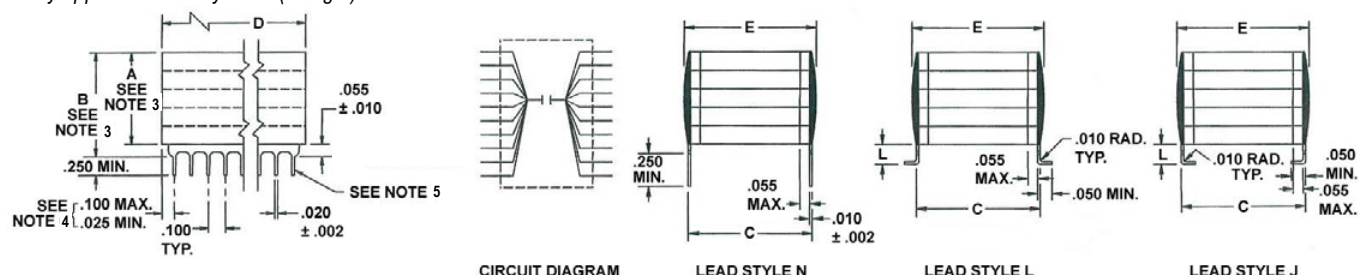

1. Unless otherwise specified, tolerances are ±.010" (0.25mm).
2. Metric equivalents for C, D and E dimensions are provided for general information only.
3. For maximum B dimension, add .065" (1.65mm) to the appropriate A dimension. For all lead styles, the number of chips is determined by the capacitance and voltage rating.
4. For case code 5, dimensions shall be .100" (2.54mm) maximum and .012" (0.30mm) minimum.
5. Lead alignment within pin rows shall be within ±.005" (0.13mm).

## Unencapsulated & Encapsulated Lead Configurations – Inches (Millimeters)

Lead Style Symbol	Lead Style	L Lead Length
N	(N) Straight	0.250 Min. (6.35)
L	(L) Formed	0.070 ± 0.010 (1.78 ± 0.25)
M		0.045 ± 0.010 (1.14 ± 0.25)
J	(J) Formed	0.070 ± 0.010 (1.78 ± 0.25)
K		0.045 ± 0.010 (1.14 ± 0.25)

Additional lead configurations may be available. Contact KEMET for details.

## Encapsulated (M49470/2 & L2) Product Dimensions – Inches (Millimeters)

Case Code	C Lead Spacing ±0.025 (0.635)	E Length Max.	D Width ±0.635 (±0.025)	A Height	Number of Leads per Side	Mounting Technique
3	0.450 (11.43)	0.580 (14.73)	1.155 (29.34)	Refer to table 1B for specific maximum A dimension	10	Solder reflow only
4	0.400 (10.16)	0.485 (12.32)	0.485 (12.32)		4	
5	0.250 (6.35)	0.355 (9.02)	0.355 (9.02)		3	

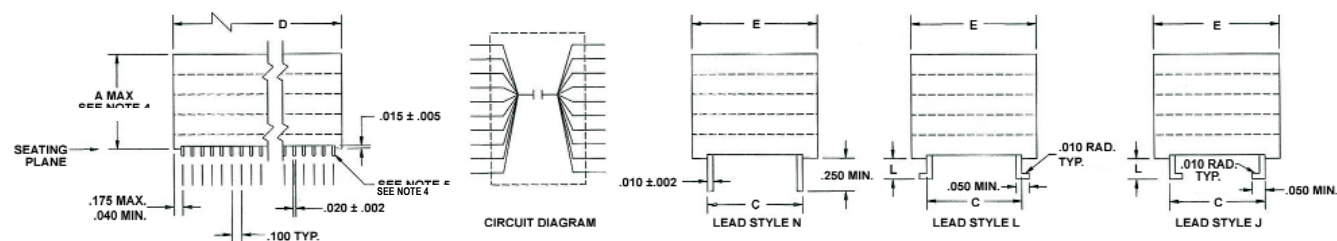

1. Dimensions are in inches.
2. Metric equivalents are given for general information only.
3. Unless otherwise specified, tolerances are ±.010" (0.25mm).
4. Lead alignment within pin rows shall be within ±.005" (0.13mm).

## Unencapsulated & Encapsulated Lead Configurations – Inches (Millimeters)

Lead Style Symbol	Lead Style	L Lead Length
N	(N) Straight	0.250 Min. (6.35)
L	(L) Formed	0.070 ± 0.010 (1.78 ± 0.25)
M		0.045 ± 0.010 (1.14 ± 0.25)
J	(J) Formed	0.070 ± 0.010 (1.78 ± 0.25)
K		0.045 ± 0.010 (1.14 ± 0.25)

Additional lead configurations may be available. Contact KEMET for details.

## Qualification Inspection Per MIL-PRF-49470

Inspection	Test Method Paragraph
<b>Group I</b>	
Thermal shock and voltage conditioning	4.8.5
<b>Group II</b>	
Visual and mechanical Inspection	4.8.4
<b>Group III</b>	
Low temperature storage	4.8.23
Barometric pressure	4.8.9
Terminal strength	4.8.10
<b>Group IV</b>	
Voltage-temperature limits	4.8.13.1
Vibration, high frequency	4.8.14
Immersion	4.8.15
<b>Group V</b>	
Shock, specified pulse	4.8.16
Resistance to soldering heat	4.8.17
Moisture resistance	4.8.18
<b>Group VI</b>	
DPA (T level only)	4.8.19
<b>Group VII</b>	
Humidity, steady state, low voltage (T level only)	4.8.21
<b>Group VIII</b>	
Life	4.8.22

## Environmental Compliance

These devices do not meet RoHS criteria

## Electrical Parameters/Performance Characteristics: BQ Dielectric

Item	Parameters/Characteristics
Operating Temperature Range	-55°C to +125°C
Capacitance Change with Reference to +25°C and 0 VDC Applied (TCC)	±15%
Capacitance Change with Reference to +25°C and 100% Rated VDC Applied	+15%, -50%
Aging Rate (Max % Cap Loss/Decade Hour)	1%
Dielectric Withstanding Voltage	250% of rated DC voltage for voltage rating < 500V 150% of rated DC voltage for voltage rating of 500V (5 ± 1 seconds and charge/discharge not exceeding 50mA)
Dissipation Factor (DF) Maximum Limit @ 25°C	2.5%
Insulation Resistance (IR) Limit @ 25°C	1000 megohm microfarads (minimum) or 100GΩ
Insulation Resistance (IR) Limit @ 125°C	100 megohm microfarads (minimum) or 10GΩ

Regarding aging rate: Capacitance measurements (including tolerance) are indexed to a referee time of 1000 hours.

To obtain IR limit, divide MΩ-μF value by the capacitance and compare to GΩ limit. Select the lower of the two limits.

Capacitance and Dissipation Factor (DF) measured under the following conditions:

1kHz ± 100Hz at 1.0Vrms ± 0.2 Vrms (open circuit voltage).

Note: When measuring capacitance it is important to ensure the set voltage level is held constant. The HP4284 & Agilent E4980 have a feature known as Automatic Level Control (ALC). The ALC feature should be switched to "ON."

## Electrical Parameters/Performance Characteristics: BR Dielectric

Item	Parameters/Characteristics
Operating Temperature Range	-55°C to +125°C
Capacitance Change with Reference to +25°C and 0 VDC Applied (TCC)	±15%
Capacitance Change with Reference to +25°C and 100% Rated VDC Applied	+15%, -40%
Aging Rate (Max % Cap Loss/Decade Hour)	1%
Dielectric Withstanding Voltage	250% of rated DC voltage for voltage rating < 500V 150% of rated DC voltage for voltage rating of 500V (5 ± 1 seconds and charge/discharge not exceeding 50mA)
Dissipation Factor (DF) Maximum Limit @ 25°C	2.5%
Insulation Resistance (IR) Limit @ 25°C	1000 megohm microfarads (minimum) or 100GΩ
Insulation Resistance (IR) Limit @ 125°C	100 megohm microfarads (minimum) or 10GΩ

Regarding aging rate: Capacitance measurements (including tolerance) are indexed to a referee time of 1000 hours.

To obtain IR limit, divide MΩ-μF value by the capacitance and compare to GΩ limit. Select the lower of the two limits.

Capacitance and Dissipation Factor (DF) measured under the following conditions:

1kHz ± 100Hz at 1.0Vrms ± 0.2 Vrms (open circuit voltage).

Note: When measuring capacitance it is important to ensure the set voltage level is held constant. The HP4284 & Agilent E4980 have a feature known as Automatic Level Control (ALC). The ALC feature should be switched to "ON."

## Electrical Parameters/Performance Characteristics: BX Dielectric

Item	Parameters/Characteristics
Operating Temperature Range	-55°C to +125°C
Capacitance Change with Reference to +25°C and 0 VDC Applied (TCC)	±15%
Capacitance Change with Reference to +25°C and 100% Rated VDC Applied	+15%, -25%
Aging Rate (Max % Cap Loss/Decade Hour)	1%
Dielectric Withstanding Voltage	250% of rated DC voltage for voltage rating < 500V 150% of rated DC voltage for voltage rating of 500V (5 ± 1 seconds and charge/discharge not exceeding 50mA)
Dissipation Factor (DF) Maximum Limit @ 25°C	2.5%
Insulation Resistance (IR) Limit @ 25°C	1000 megohm microfarads (minimum) or 100GΩ
Insulation Resistance (IR) Limit @ 125°C	100 megohm microfarads (minimum) or 10GΩ

Regarding aging rate: Capacitance measurements (including tolerance) are indexed to a referee time of 1000 hours.

To obtain IR limit, divide MΩ-μF value by the capacitance and compare to GΩ limit. Select the lower of the two limits.

Capacitance and Dissipation Factor (DF) measured under the following conditions:

1kHz ± 100Hz at 1.0Vrms ± 0.2 Vrms (open circuit voltage).

Note: When measuring capacitance it is important to ensure the set voltage level is held constant. The HP4284 & Agilent E4980 have a feature known as Automatic Level Control (ALC). The ALC feature should be switched to "ON."

## Electrical Parameters/Performance Characteristics: X7R Dielectric

Item	Parameters/Characteristics
Operating Temperature Range	-55°C to +125°C
Capacitance Change with Reference to +25°C and 0 VDC Applied (TCC)	±15%
Aging Rate (Max % Cap Loss/Decade Hour)	3.0%
Dielectric Withstanding Voltage	250% of rated voltage (5 ± 1 seconds and charge/discharge not exceeding 50mA)
Dissipation Factor (DF) Maximum Limit @ 25°C	3.5% (25V) and 2.5% (50V to 200V)
Insulation Resistance (IR) Limit @ 25°C	1000 megohm microfarads or 100GΩ (Rated voltage applied for 120 ± 5 secs @ 25°C)

Regarding aging rate: Capacitance measurements (including tolerance) are indexed to a referee time of 1000 hours.

To obtain IR limit, divide MΩ-μF value by the capacitance and compare to GΩ limit. Select the lower of the two limits.

Capacitance and Dissipation Factor (DF) measured under the following conditions:

1kHz ± 50Hz and 1.0 ± 0.2 Vrms if capacitance ≤ 10μF.

20Hz ± 10Hz and 0.5 ± 0.1 Vrms if capacitance > 10μF.

Note: When measuring capacitance it is important to ensure the set voltage level is held constant. The HP4284 & Agilent E4980 have a feature known as Automatic Level Control (ALC). The ALC feature should be switched to "ON."



**Table 1A – MIL-PRF-49470/1, Product Selection 50VDC-200VDC**

MIL-PRF-49470/1 Unencapsulated, Horizontally Stacked						
MIL-PRF-49470 P/N <sup>1</sup>	Cap (µF)	Case Code	Height A inch (mm)	Cap Tol.	Lead Config.	KEMET P/N <sup>1</sup>
<b>50VDC - BX Dielectric</b>						
(1)49470X01105(2)A(3)	1	5	0.120 (3.05)	K, M	N, L, M, J, K	L1X(3)505105(2)(4)12
(1)49470X01125(2)A(3)	1.2	5	0.120 (3.05)	K, M	N, L, M, J, K	L1X(3)505125(2)(4)12
(1)49470X01155(2)A(3)	1.5	5	0.240 (6.10)	K, M	N, L, M, J, K	L1X(3)505155(2)(4)24
(1)49470X01185(2)A(3)	1.8	5	0.240 (6.10)	K, M	N, L, M, J, K	L1X(3)505185(2)(4)24
(1)49470X01225(2)A(3)	2.2	5	0.240 (6.10)	K, M	N, L, M, J, K	L1X(3)505225(2)(4)24
(1)49470X01275(2)A(3)	2.7	5	0.360 (9.14)	K, M	N, L, M, J, K	L1X(3)505275(2)(4)36
(1)49470X01335(2)A(3)	3.3	5	0.360 (9.14)	K, M	N, L, M, J, K	L1X(3)505335(2)(4)36
(1)49470X01475(2)A(3)	3.9	5	0.480 (12.19)	K, M	N, L, M, J, K	L1X(3)505475(2)(4)48
(1)49470X01395(2)A(3)	3.9	5	0.480 (12.19)	K, M	N, L, M, J, K	L1X(3)505395(2)(4)48
(1)49470X01565(2)A(3)	5.6	5	0.650 (16.51)	K, M	N, L, M, J, K	L1X(3)505565(2)(4)65
(1)49470X01685(2)A(3)	6.8	4	0.360 (9.14)	K, M	N, L, M, J, K	L1X(3)405685(2)(4)36
(1)49470X01825(2)A(3)	8.2	4	0.360 (9.14)	K, M	N, L, M, J, K	L1X(3)405825(2)(4)36
(1)49470X01106(2)A(3)	10	4	0.480 (12.19)	K, M	N, L, M, J, K	L1X(3)405106(2)(4)48
(1)49470X01126(2)A(3)	12	4	0.480 (12.19)	K, M	N, L, M, J, K	L1X(3)405126(2)(4)48
(1)49470X01156(2)A(3)	15	4	0.650 (16.51)	K, M	N, L, M, J, K	L1X(3)405156(2)(4)65
(1)49470X01186(2)A(3)	18	3	0.240 (6.10)	K, M	N, L, M, J, K	L1X(3)305186(2)(4)24
(1)49470X01226(2)A(3)	22	3	0.360 (9.14)	K, M	N, L, M, J, K	L1X(3)305226(2)(4)36
(1)49470X01276(2)A(3)	27	3	0.360 (9.14)	K, M	N, L, M, J, K	L1X(3)305276(2)(4)36
(1)49470X01336(2)A(3)	33	3	0.360 (9.14)	K, M	N, L, M, J, K	L1X(3)305336(2)(4)36
(1)49470X01396(2)A(3)	39	3	0.480 (12.19)	K, M	N, L, M, J, K	L1X(3)305396(2)(4)48
(1)49470X01476(2)A(3)	47	3	0.650 (16.51)	K, M	N, L, M, J, K	L1X(3)305476(2)(4)65
<b>100VDC - BX Dielectric</b>						
(1)49470X01684(2)B(3)	0.68	5	0.120 (3.05)	K, M	N, L, M, J, K	L1X(3)501684(2)(4)12
(1)49470X01824(2)B(3)	0.82	5	0.240 (6.10)	K, M	N, L, M, J, K	L1X(3)501824(2)(4)24
(1)49470X01105(2)B(3)	1	5	0.240 (6.10)	K, M	N, L, M, J, K	L1X(3)501105(2)(4)24
(1)49470X01125(2)B(3)	1.2	5	0.240 (6.10)	K, M	N, L, M, J, K	L1X(3)501125(2)(4)24
(1)49470X01155(2)B(3)	1.5	5	0.360 (9.14)	K, M	N, L, M, J, K	L1X(3)501155(2)(4)36
(1)49470X01185(2)B(3)	1.8	5	0.360 (9.14)	K, M	N, L, M, J, K	L1X(3)501185(2)(4)36
(1)49470X01225(2)B(3)	2.2	5	0.480 (12.19)	K, M	N, L, M, J, K	L1X(3)501225(2)(4)48
(1)49470X01275(2)B(3)	2.7	5	0.480 (12.19)	K, M	N, L, M, J, K	L1X(3)501275(2)(4)48
(1)49470X01335(2)B(3)	3.3	5	0.650 (16.51)	K, M	N, L, M, J, K	L1X(3)501335(2)(4)65
(1)49470X01395(2)B(3)	3.9	4	0.360 (9.14)	K, M	N, L, M, J, K	L1X(3)401395(2)(4)36
(1)49470X01475(2)B(3)	4.7	4	0.360 (9.14)	K, M	N, L, M, J, K	L1X(3)401475(2)(4)36
(1)49470X01565(2)B(3)	5.6	4	0.480 (12.19)	K, M	N, L, M, J, K	L1X(3)401565(2)(4)48
(1)49470X01685(2)B(3)	6.8	4	0.480 (12.19)	K, M	N, L, M, J, K	L1X(3)401685(2)(4)48
(1)49470X01825(2)B(3)	8.2	4	0.650 (16.51)	K, M	N, L, M, J, K	L1X(3)401825(2)(4)65
(1)49470X01106(2)B(3)	10	3	0.240 (6.10)	K, M	N, L, M, J, K	L1X(3)301106(2)(4)24
(1)49470X01126(2)B(3)	12	3	0.240 (6.10)	K, M	N, L, M, J, K	L1X(3)301126(2)(4)24
(1)49470X01156(2)B(3)	15	3	0.360 (9.14)	K, M	N, L, M, J, K	L1X(3)301156(2)(4)36
(1)49470X01186(2)B(3)	18	3	0.360 (9.14)	K, M	N, L, M, J, K	L1X(3)301186(2)(4)36
(1)49470X01226(2)B(3)	22	3	0.480 (12.19)	K, M	N, L, M, J, K	L1X(3)301226(2)(4)48
(1)49470X01276(2)B(3)	27	3	0.650 (16.51)	K, M	N, L, M, J, K	L1X(3)301276(2)(4)65
<b>200VDC - BR Dielectric</b>						
(1)49470R01474(2)C(3)	0.47	5	0.240 (6.10)	K, M	N, L, M, J, K	L1R(3)502474(2)(4)24
(1)49470R01564(2)C(3)	0.56	5	0.240 (6.10)	K, M	N, L, M, J, K	L1R(3)502564(2)(4)24
(1)49470R01684(2)C(3)	0.68	5	0.360 (9.14)	K, M	N, L, M, J, K	L1R(3)502684(2)(4)36
(1)49470R01824(2)C(3)	0.82	5	0.360 (9.14)	K, M	N, L, M, J, K	L1R(3)502824(2)(4)36
(1)49470R01105(2)C(3)	1	5	0.480 (12.19)	K, M	N, L, M, J, K	L1R(3)502105(2)(4)48
MIL-PRF-49470 P/N <sup>1</sup>	Cap (µF)	Case Code	Height A inch (mm)	Cap Tolerance	Lead Config.	KEMET P/N <sup>1</sup>

<sup>1</sup> Complete P/N requires additional characters in the numbered positions provided in order to indicate product level (B level or T level), capacitance tolerance and lead configuration. For each numbered position, available options are as follows:

- (1) Test level character "M" for B level, or "T" for T level (MIL-PRF-49470/1 part number only)
- (2) Capacitance tolerance character "K" or "M"
- (3) Lead style character "N", "L", "M", "J" or "K"
- (4) Test level character "B" for B level, or "T" for T level (KEMET part number only)

**Table 1A – MIL-PRF-49470 /1, Product Selection 200VDC-500VDC con't.**

MIL-PRF-49470/1 Unencapsulated, Horizontally Stacked						
MIL-PRF-49470 P/N <sup>1</sup>	Cap (µF)	Case Code	Height A inch (mm)	Cap Tol.	Lead Config.	KEMET P/N <sup>1</sup>
(1)49470R01125(2)C(3)	1.2	5	0.480 (12.19)	K, M	N, L, M, J, K	L1R(3)502125(2)(4)48
(1)49470R01155(2)C(3)	1.5	5	0.650 (16.51)	K, M	N, L, M, J, K	L1R(3)502155(2)(4)65
(1)49470R01185(2)C(3)	1.8	4	0.360 (9.14)	K, M	N, L, M, J, K	L1R(3)402185(2)(4)36
(1)49470R01225(2)C(3)	2.2	4	0.360 (9.14)	K, M	N, L, M, J, K	L1R(3)402225(2)(4)36
(1)49470R01275(2)C(3)	2.7	4	0.480 (12.19)	K, M	N, L, M, J, K	L1R(3)402275(2)(4)48
(1)49470R01335(2)C(3)	3.3	4	0.480 (12.19)	K, M	N, L, M, J, K	L1R(3)402335(2)(4)48
(1)49470R01395(2)C(3)	3.9	4	0.650 (16.51)	K, M	N, L, M, J, K	L1R(3)402395(2)(4)65
(1)49470R01475(2)C(3)	4.7	3	0.240 (6.10)	K, M	N, L, M, J, K	L1R(3)302475(2)(4)24
(1)49470R01565(2)C(3)	5.6	3	0.240 (6.10)	K, M	N, L, M, J, K	L1R(3)302565(2)(4)24
(1)49470R01685(2)C(3)	6.8	3	0.360 (9.14)	K, M	N, L, M, J, K	L1R(3)302685(2)(4)36
(1)49470R01825(2)C(3)	8.2	3	0.360 (9.14)	K, M	N, L, M, J, K	L1R(3)302825(2)(4)36
(1)49470R01106(2)C(3)	10	3	0.480 (12.19)	K, M	N, L, M, J, K	L1R(3)302106(2)(4)48
(1)49470R01126(2)C(3)	12	3	0.650 (16.51)	K, M	N, L, M, J, K	L1R(3)302126(2)(4)65
500VDC - BQ Dielectric						
(1)49470Q01154(2)E(3)	0.15	5	0.120 (3.05)	K, M	N, L, M, J, K	L1Q(3)50C154(2)(4)12
(1)49470Q01184(2)E(3)	0.18	5	0.240 (6.10)	K, M	N, L, M, J, K	L1Q(3)50C184(2)(4)24
(1)49470Q01224(2)E(3)	0.22	5	0.240 (6.10)	K, M	N, L, M, J, K	L1Q(3)50C224(2)(4)24
(1)49470Q01274(2)E(3)	0.27	5	0.240 (6.10)	K, M	N, L, M, J, K	L1Q(3)50C274(2)(4)24
(1)49470Q01334(2)E(3)	0.33	5	0.360 (9.14)	K, M	N, L, M, J, K	L1Q(3)50C334(2)(4)36
(1)49470Q01394(2)E(3)	0.39	5	0.360 (9.14)	K, M	N, L, M, J, K	L1Q(3)50C394(2)(4)36
(1)49470Q01474(2)E(3)	0.47	5	0.360 (9.14)	K, M	N, L, M, J, K	L1Q(3)50C474(2)(4)36
(1)49470Q01564(2)E(3)	0.56	5	0.480 (12.19)	K, M	N, L, M, J, K	L1Q(3)50C564(2)(4)48
(1)49470Q01684(2)E(3)	0.68	5	0.650 (16.51)	K, M	N, L, M, J, K	L1Q(3)50C684(2)(4)65
(1)49470Q01824(2)E(3)	0.82	4	0.360 (9.14)	K, M	N, L, M, J, K	L1Q(3)40C824(2)(4)36
(1)49470Q01105(2)E(3)	1	4	0.360 (9.14)	K, M	N, L, M, J, K	L1Q(3)40C105(2)(4)36
(1)49470Q01125(2)E(3)	1.2	4	0.360 (9.14)	K, M	N, L, M, J, K	L1Q(3)40C125(2)(4)36
(1)49470Q01155(2)E(3)	1.5	4	0.480 (12.19)	K, M	N, L, M, J, K	L1Q(3)40C155(2)(4)48
(1)49470Q01185(2)E(3)	1.8	4	0.650 (16.51)	K, M	N, L, M, J, K	L1Q(3)40C185(2)(4)65
(1)49470Q01225(2)E(3)	2.2	3	0.240 (6.10)	K, M	N, L, M, J, K	L1Q(3)30C225(2)(4)24
(1)49470Q01275(2)E(3)	2.7	3	0.360 (9.14)	K, M	N, L, M, J, K	L1Q(3)30C275(2)(4)36
(1)49470Q01335(2)E(3)	3.3	3	0.360 (9.14)	K, M	N, L, M, J, K	L1Q(3)30C335(2)(4)36
(1)49470Q01395(2)E(3)	3.9	3	0.360 (9.14)	K, M	N, L, M, J, K	L1Q(3)30C395(2)(4)36
(1)49470Q01475(2)E(3)	4.7	3	0.480 (12.19)	K, M	N, L, M, J, K	L1Q(3)30C475(2)(4)48
(1)49470Q01565(2)E(3)	5.6	3	0.650 (16.51)	K, M	N, L, M, J, K	L1Q(3)30C565(2)(4)65
MIL-PRF-49470 P/N <sup>1</sup>	Cap (µF)	Case Code	Height A inch (mm)	Cap Tolerance	Lead Config.	KEMET P/N <sup>1</sup>

<sup>1</sup> Complete P/N requires additional characters in the numbered positions provided in order to indicate product level (B level or T level), capacitance tolerance and lead configuration. For each numbered position, available options are as follows:

- (1) Test level character "M" for B level, or "T" for T level (MIL-PRF-49470/1 part number only)
- (2) Capacitance tolerance character "K" or "M"
- (3) Lead style character "N", "L", "M", "J" or "K"
- (4) Test level character "B" for B level, or "T" for T level (KEMET part number only)

**Table 1B – MIL-PRF-49470/2, Product Selection 50VDC-200VDC**

MIL-PRF-49470/2 Encapsulated, Horizontally Stacked						
MIL-PRF-49470 P/N <sup>1</sup>	Cap (µF)	Case Code	Height A inch (mm)	Cap Tol.	Lead Config.	KEMET P/N <sup>1</sup>
<b>50VDC - BX Dielectric</b>						
M49470X02125(1)A(2)	1.2	5	0.270 (6.86)	K, M	N, L, M, J, K	L2X(2)505125(1)B27
M49470X02155(1)A(2)	1.5	5	0.390 (9.91)	K, M	N, L, M, J, K	L2X(2)505155(1)B39
M49470X02185(1)A(2)	1.8	5	0.390 (9.91)	K, M	N, L, M, J, K	L2X(2)505185(1)B39
M49470X02225(1)A(2)	2.2	5	0.390 (9.91)	K, M	N, L, M, J, K	L2X(2)505225(1)B39
M49470X02275(1)A(2)	2.7	5	0.530 (13.46)	K, M	N, L, M, J, K	L2X(2)505275(1)B53
M49470X02335(1)A(2)	3.3	5	0.530 (13.46)	K, M	N, L, M, J, K	L2X(2)505335(1)B53
M49470X02475(1)A(2)	3.9	5	0.660 (16.76)	K, M	N, L, M, J, K	L2X(2)505475(1)B66
M49470X02395(1)A(2)	4.7	5	0.660 (16.76)	K, M	N, L, M, J, K	L2X(2)505395(1)B66
M49470X02565(1)A(2)	5.6	5	0.800 (20.32)	K, M	N, L, M, J, K	L2X(2)505565(1)B80
M49470X02685(1)A(2)	6.8	4	0.530 (13.46)	K, M	N, L, M, J, K	L2X(2)405685(1)B53
M49470X02825(1)A(2)	8.2	4	0.530 (13.46)	K, M	N, L, M, J, K	L2X(2)405825(1)B53
M49470X02106(1)A(2)	10	4	0.660 (16.76)	K, M	N, L, M, J, K	L2X(2)405106(1)B66
M49470X02126(1)A(2)	12	4	0.660 (16.76)	K, M	N, L, M, J, K	L2X(2)405126(1)B66
M49470X02156(1)A(2)	15	4	0.800 (20.32)	K, M	N, L, M, J, K	L2X(2)405156(1)B80
M49470X02186(1)A(2)	18	3	0.390 (9.91)	K, M	N, L, M, J, K	L2X(2)305186(1)B39
M49470X02226(1)A(2)	22	3	0.530 (13.46)	K, M	N, L, M, J, K	L2X(2)305226(1)B53
M49470X02276(1)A(2)	27	3	0.530 (13.46)	K, M	N, L, M, J, K	L2X(2)305276(1)B53
M49470X02336(1)A(2)	33	3	0.530 (13.46)	K, M	N, L, M, J, K	L2X(2)305336(1)B53
M49470X02396(1)A(2)	39	3	0.660 (16.76)	K, M	N, L, M, J, K	L2X(2)305396(1)B66
M49470X02476(1)A(2)	47	3	0.800 (20.32)	K, M	N, L, M, J, K	L2X(2)305476(1)B80
<b>100VDC - BX Dielectric</b>						
M49470X02684(1)B(2)	0.68	5	0.270 (6.86)	K, M	N, L, M, J, K	L2X(2)501684(1)B27
M49470X02824(1)B(2)	0.82	5	0.390 (9.91)	K, M	N, L, M, J, K	L2X(2)501824(1)B39
M49470X02105(1)B(2)	1	5	0.390 (9.91)	K, M	N, L, M, J, K	L2X(2)501105(1)B39
M49470X02125(1)B(2)	1.2	5	0.390 (9.91)	K, M	N, L, M, J, K	L2X(2)501125(1)B39
M49470X02155(1)B(2)	1.5	5	0.530 (13.46)	K, M	N, L, M, J, K	L2X(2)501155(1)B53
M49470X02185(1)B(2)	1.8	5	0.530 (13.46)	K, M	N, L, M, J, K	L2X(2)501185(1)B53
M49470X02225(1)B(2)	2.2	5	0.660 (16.76)	K, M	N, L, M, J, K	L2X(2)501225(1)B66
M49470X02275(1)B(2)	2.7	5	0.660 (16.76)	K, M	N, L, M, J, K	L2X(2)501275(1)B66
M49470X02335(1)B(2)	3.3	5	0.800 (20.32)	K, M	N, L, M, J, K	L2X(2)501335(1)B80
M49470X02395(1)B(2)	3.9	4	0.530 (13.46)	K, M	N, L, M, J, K	L2X(2)401395(1)B53
M49470X02475(1)B(2)	4.7	4	0.530 (13.46)	K, M	N, L, M, J, K	L2X(2)401475(1)B53
M49470X02565(1)B(2)	5.6	4	0.660 (16.76)	K, M	N, L, M, J, K	L2X(2)401565(1)B66
M49470X02685(1)B(2)	6.8	4	0.660 (16.76)	K, M	N, L, M, J, K	L2X(2)401685(1)B66
M49470X02825(1)B(2)	8.2	4	0.800 (20.32)	K, M	N, L, M, J, K	L2X(2)401825(1)B80
M49470X02106(1)B(2)	10	3	0.390 (9.91)	K, M	N, L, M, J, K	L2X(2)301106(1)B39
M49470X02126(1)B(2)	12	3	0.390 (9.91)	K, M	N, L, M, J, K	L2X(2)301126(1)B39
M49470X02156(1)B(2)	15	3	0.530 (13.46)	K, M	N, L, M, J, K	L2X(2)301156(1)B53
M49470X02186(1)B(2)	18	3	0.530 (13.46)	K, M	N, L, M, J, K	L2X(2)301186(1)B53
M49470X02226(1)B(2)	22	3	0.660 (16.76)	K, M	N, L, M, J, K	L2X(2)301226(1)B66
M49470X02276(1)B(2)	27	3	0.800 (20.32)	K, M	N, L, M, J, K	L2X(2)301276(1)B80
<b>200VDC - BR Dielectric</b>						
M49470R02474(1)C(2)	0.47	5	0.390 (9.91)	K, M	N, L, M, J, K	L2R(2)502474(1)B39
M49470R02564(1)C(2)	0.56	5	0.390 (9.91)	K, M	N, L, M, J, K	L2R(2)502564(1)B39
M49470R02684(1)C(2)	0.68	5	0.530 (13.46)	K, M	N, L, M, J, K	L2R(2)502684(1)B53
M49470R02824(1)C(2)	0.82	5	0.530 (13.46)	K, M	N, L, M, J, K	L2R(2)502824(1)B53
M49470R02105(1)C(2)	1	5	0.660 (16.76)	K, M	N, L, M, J, K	L2R(2)502105(1)B66
M49470R02125(1)C(2)	1.2	5	0.660 (16.76)	K, M	N, L, M, J, K	L2R(2)502125(1)B66
M49470R02155(1)C(2)	1.5	5	0.800 (20.32)	K, M	N, L, M, J, K	L2R(2)502155(1)B80
M49470R02185(1)C(2)	1.8	4	0.530 (13.46)	K, M	N, L, M, J, K	L2R(2)402185(1)B53
M49470R02225(1)C(2)	2.2	4	0.530 (13.46)	K, M	N, L, M, J, K	L2R(2)402225(1)B53
<b>MIL-PRF-49470 P/N <sup>1</sup></b>	<b>Cap (µF)</b>	<b>Case Code</b>	<b>Height A inch (mm)</b>	<b>Cap Tolerance</b>	<b>Lead Config.</b>	<b>KEMET P/N <sup>1</sup></b>

<sup>1</sup> Complete P/N requires additional characters in the numbered positions provided in order to indicate capacitance tolerance and lead configuration. For each numbered position, available options are as follows:

- (1) Capacitance tolerance character "K" or "M"
- (2) Lead style character "N", "L", "M", "J" or "K"

**Table 1B – MIL-PRF-49470 /2, Product Selection 200VDC-500VDC con't**

MIL-PRF-49470/2 Encapsulated, Horizontally Stacked						
MIL-PRF-49470 P/N <sup>1</sup>	Cap (µF)	Case Code	Height A inch (mm)	Cap Tol.	Lead Config.	KEMET P/N <sup>1</sup>
M49470R02275(1)C(2)	2.7	4	0.660 (16.76)	K, M	N, L, M, J, K	L2R(2)402275(1)B66
M49470R02335(1)C(2)	3.3	4	0.660 (16.76)	K, M	N, L, M, J, K	L2R(2)402335(1)B66
M49470R02395(1)C(2)	3.9	4	0.800 (20.32)	K, M	N, L, M, J, K	L2R(2)402395(1)B80
M49470R02475(1)C(2)	4.7	3	0.390 (9.91)	K, M	N, L, M, J, K	L2R(2)302475(1)B39
M49470R02565(1)C(2)	5.6	3	0.390 (9.91)	K, M	N, L, M, J, K	L2R(2)302565(1)B39
M49470R02685(1)C(2)	6.8	3	0.530 (13.46)	K, M	N, L, M, J, K	L2R(2)302685(1)B53
M49470R02825(1)C(2)	8.2	3	0.530 (13.46)	K, M	N, L, M, J, K	L2R(2)302825(1)B53
M49470R02106(1)C(2)	10	3	0.660 (16.76)	K, M	N, L, M, J, K	L2R(2)302106(1)B66
M49470R02126(1)C(2)	12	3	0.800 (20.32)	K, M	N, L, M, J, K	L2R(2)302126(1)B80
500VDC - BQ Dielectric						
M49470Q02154(1)E(2)	0.15	5	0.270 (6.86)	K, M	N, L, M, J, K	L2Q(2)50C154(1)B27
M49470Q02184(1)E(2)	0.18	5	0.390 (9.91)	K, M	N, L, M, J, K	L2Q(2)50C184(1)B39
M49470Q02224(1)E(2)	0.22	5	0.390 (9.91)	K, M	N, L, M, J, K	L2Q(2)50C224(1)B39
M49470Q02274(1)E(2)	0.27	5	0.390 (9.91)	K, M	N, L, M, J, K	L2Q(2)50C274(1)B39
M49470Q02334(1)E(2)	0.33	5	0.530 (13.46)	K, M	N, L, M, J, K	L2Q(2)50C334(1)B53
M49470Q02394(1)E(2)	0.39	5	0.530 (13.46)	K, M	N, L, M, J, K	L2Q(2)50C394(1)B53
M49470Q02474(1)E(2)	0.47	5	0.530 (13.46)	K, M	N, L, M, J, K	L2Q(2)50C474(1)B53
M49470Q02564(1)E(2)	0.56	5	0.660 (16.76)	K, M	N, L, M, J, K	L2Q(2)50C564(1)B66
M49470Q02684(1)E(2)	0.68	5	0.800 (20.32)	K, M	N, L, M, J, K	L2Q(2)50C684(1)B80
M49470Q02824(1)E(2)	0.82	4	0.530 (13.46)	K, M	N, L, M, J, K	L2Q(2)40C824(1)B53
M49470Q02105(1)E(2)	1	4	0.530 (13.46)	K, M	N, L, M, J, K	L2Q(2)40C105(1)B53
M49470Q02125(1)E(2)	1.2	4	0.530 (13.46)	K, M	N, L, M, J, K	L2Q(2)40C125(1)B53
M49470Q02155(1)E(2)	1.5	4	0.660 (16.76)	K, M	N, L, M, J, K	L2Q(2)40C155(1)B66
M49470Q02185(1)E(2)	1.8	4	0.800 (20.32)	K, M	N, L, M, J, K	L2Q(2)40C185(1)B80
M49470Q02225(1)E(2)	2.2	3	0.390 (9.91)	K, M	N, L, M, J, K	L2Q(2)30C225(1)B39
M49470Q02275(1)E(2)	2.7	3	0.530 (13.46)	K, M	N, L, M, J, K	L2Q(2)30C275(1)B53
M49470Q02335(1)E(2)	3.3	3	0.530 (13.46)	K, M	N, L, M, J, K	L2Q(2)30C335(1)B53
M49470Q02395(1)E(2)	3.9	3	0.530 (13.46)	K, M	N, L, M, J, K	L2Q(2)30C395(1)B53
M49470Q02475(1)E(2)	4.7	3	0.660 (16.76)	K, M	N, L, M, J, K	L2Q(2)30C475(1)B66
M49470Q02565(1)E(2)	5.6	3	0.800 (20.32)	K, M	N, L, M, J, K	L2Q(2)30C565(1)B80
M49470Q02565(1)E(2)	5.6	3	0.800 (20.32)	K, M	N, L, M, J, K	L2Q(2)30C565(1)B65
MIL-PRF-49470 P/N <sup>1</sup>	Cap (µF)	Case Code	Height A inch (mm)	Cap Tolerance	Lead Config.	KEMET P/N <sup>1</sup>

<sup>1</sup> Complete P/N requires additional characters in the numbered positions provided in order to indicate capacitance tolerance and lead configuration. For each numbered position, available options are as follows:

- (1) Capacitance tolerance character "K" or "M"
- (2) Lead style character "N", "L", "M", "J" or "K"

**Table 1C – Product Selection 25VDC**

<b>Commercial/Non-Standard – Customer Specific Unencapsulated, Horizontally Stacked</b>					
<b>KEMET P/N <sup>1</sup></b>	<b>Cap (µF)</b>	<b>Case Code</b>	<b>Height A inch (mm)</b>	<b>Cap Tolerance</b>	<b>Lead Config.</b>
<b>25VDC - BX Dielectric</b>					
L1X(1)503824(2)(3)12	0.82	5	0.120 (3.05)	K, M	N, L, M, J, K
L1X(1)503105(2)(3)12	1	5	0.120 (3.05)	K, M	N, L, M, J, K
L1X(1)503125(2)(3)12	1.2	5	0.120 (3.05)	K, M	N, L, M, J, K
L1X(1)503155(2)(3)12	1.5	5	0.120 (3.05)	K, M	N, L, M, J, K
L1X(1)503185(2)(3)24	1.8	5	0.240 (6.10)	K, M	N, L, M, J, K
L1X(1)403225(2)(3)12	2.2	4	0.120 (3.05)	K, M	N, L, M, J, K
L1X(1)503225(2)(3)24	2.2	5	0.240 (6.10)	K, M	N, L, M, J, K
L1X(1)503255(2)(3)24	2.5	5	0.240 (6.10)	K, M	N, L, M, J, K
L1X(1)403275(2)(3)12	2.7	4	0.120 (3.05)	K, M	N, L, M, J, K
L1X(1)503275(2)(3)24	2.7	5	0.240 (6.10)	K, M	N, L, M, J, K
L1X(1)403335(2)(3)12	3.3	4	0.120 (3.05)	K, M	N, L, M, J, K
L1X(1)503335(2)(3)36	3.3	5	0.360 (9.14)	K, M	N, L, M, J, K
L1X(1)403395(2)(3)12	3.9	4	0.120 (3.05)	K, M	N, L, M, J, K
L1X(1)503395(2)(3)36	3.9	5	0.360 (9.14)	K, M	N, L, M, J, K
L1X(1)403475(2)(3)12	4.7	4	0.120 (3.05)	K, M	N, L, M, J, K
L1X(1)503475(2)(3)36	4.7	5	0.360 (9.14)	K, M	N, L, M, J, K
L1X(1)403565(2)(3)24	5.6	4	0.240 (6.10)	K, M	N, L, M, J, K
L1X(1)503565(2)(3)48	5.6	5	0.480 (12.19)	K, M	N, L, M, J, K
L1X(1)403605(2)(3)24	6	4	0.240 (6.10)	K, M	N, L, M, J, K
L1X(1)503605(2)(3)48	6	5	0.480 (12.19)	K, M	N, L, M, J, K
L1X(1)303685(2)(3)12	6.8	3	0.120 (3.05)	K, M	N, L, M, J, K
L1X(1)403685(2)(3)24	6.8	4	0.240 (6.10)	K, M	N, L, M, J, K
L1X(1)503685(2)(3)65	6.8	5	0.650 (16.51)	K, M	N, L, M, J, K
L1X(1)403755(2)(3)24	7.5	4	0.240 (6.10)	K, M	N, L, M, J, K
L1X(1)503755(2)(3)65	7.5	5	0.650 (16.51)	K, M	N, L, M, J, K
L1X(1)303825(2)(3)12	8.2	3	0.120 (3.05)	K, M	N, L, M, J, K
L1X(1)403825(2)(3)24	8.2	4	0.240 (6.10)	K, M	N, L, M, J, K
L1X(1)303106(2)(3)12	10	3	0.120 (3.05)	K, M	N, L, M, J, K
L1X(1)403106(2)(3)24	10	4	0.240 (6.10)	K, M	N, L, M, J, K
L1X(1)303116(2)(3)12	11	3	0.120 (3.05)	K, M	N, L, M, J, K
L1X(1)303126(2)(3)12	12	3	0.120 (3.05)	K, M	N, L, M, J, K
L1X(1)403126(2)(3)36	12	4	0.360 (9.14)	K, M	N, L, M, J, K
L1X(1)303156(2)(3)12	15	3	0.120 (3.05)	K, M	N, L, M, J, K
L1X(1)403156(2)(3)36	15	4	0.360 (9.14)	K, M	N, L, M, J, K
L1X(1)303166(2)(3)24	16	3	0.240 (6.10)	K, M	N, L, M, J, K
L1X(1)403166(2)(3)48	16	4	0.480 (12.19)	K, M	N, L, M, J, K
L1X(1)303186(2)(3)24	18	3	0.240 (6.10)	K, M	N, L, M, J, K
L1X(1)403186(2)(3)48	18	4	0.480 (12.19)	K, M	N, L, M, J, K
L1X(1)303206(2)(3)24	20	3	0.240 (6.10)	K, M	N, L, M, J, K
L1X(1)403206(2)(3)48	20	4	0.480 (12.19)	K, M	N, L, M, J, K
L1X(1)303226(2)(3)24	22	3	0.240 (6.10)	K, M	N, L, M, J, K
L1X(1)403226(2)(3)65	22	4	0.650 (16.51)	K, M	N, L, M, J, K
L1X(1)403246(2)(3)65	24	4	0.650 (16.51)	K, M	N, L, M, J, K
L1X(1)303276(2)(3)24	27	3	0.240 (6.10)	K, M	N, L, M, J, K
L1X(1)303306(2)(3)24	30	3	0.240 (6.10)	K, M	N, L, M, J, K
L1X(1)303306(2)(3)36	30	3	0.360 (9.14)	K, M	N, L, M, J, K
L1X(1)303336(2)(3)36	33	3	0.360 (9.14)	K, M	N, L, M, J, K
L1X(1)303396(2)(3)36	39	3	0.360 (9.14)	K, M	N, L, M, J, K
L1X(1)303456(2)(3)36	45	3	0.360 (9.14)	K, M	N, L, M, J, K
L1X(1)303506(2)(3)48	50	3	0.480 (12.19)	K, M	N, L, M, J, K
L1X(1)303546(2)(3)48	54	3	0.480 (12.19)	K, M	N, L, M, J, K
L1X(1)303606(2)(3)48	60	3	0.480 (12.19)	K, M	N, L, M, J, K
<b>KEMET P/N <sup>1</sup></b>	<b>Cap (µF)</b>	<b>Case Code</b>	<b>Height A inch (mm)</b>	<b>Cap Tolerance</b>	<b>Lead Config.</b>

<sup>1</sup> Complete part number requires additional characters in the numbered positions provided in order to indicate product level (B level or T level), capacitance tolerance and lead configuration. For each numbered position, available options are as follows:

- (1) Test Level character "S" for Commercial, or "X" for non-standard (customer specific)
- (2) Capacitance tolerance character "K" or "M"
- (3) Lead style character "N", "L", "M", "J" or "K"

**Table 1C – Commercial/Non-Standard – Product Selection 25VDC-50VDC con't.**

<b>Commercial/Non-Standard – Customer Specific Unencapsulated, Horizontally Stacked</b>					
<b>KEMET P/N <sup>1</sup></b>	<b>Cap (µF)</b>	<b>Case Code</b>	<b>Height A inch (mm)</b>	<b>Cap Tolerance</b>	<b>Lead Config.</b>
L1X(1)303666(2)(3)65	66	3	0.650 (16.51)	K, M	N, L, M, J, K
L1X(1)303726(2)(3)65	72	3	0.650 (16.51)	K, M	N, L, M, J, K
L1X(1)303756(2)(3)65	75	3	0.650 (16.51)	K, M	N, L, M, J, K
<b>50VDC - BX Dielectric</b>					
L1X(1)505824(2)(3)12	0.82	5	0.120 (3.05)	K, M	N, L, M, J, K
L1X(1)505105(2)(3)12	1	5	0.120 (3.05)	K, M	N, L, M, J, K
L1X(1)505125(2)(3)12	1.2	5	0.120 (3.05)	K, M	N, L, M, J, K
L1X(1)505155(2)(3)12	1.5	5	0.120 (3.05)	K, M	N, L, M, J, K
L1X(1)505185(2)(3)24	1.8	5	0.240 (6.10)	K, M	N, L, M, J, K
L1X(1)405225(2)(3)12	2.2	4	0.120 (3.05)	K, M	N, L, M, J, K
L1X(1)505225(2)(3)24	2.2	5	0.240 (6.10)	K, M	N, L, M, J, K
L1X(1)505255(2)(3)24	2.5	5	0.240 (6.10)	K, M	N, L, M, J, K
L1X(1)405275(2)(3)12	2.7	4	0.120 (3.05)	K, M	N, L, M, J, K
L1X(1)505275(2)(3)24	2.7	5	0.240 (6.10)	K, M	N, L, M, J, K
L1X(1)505275(2)(3)36	2.7	5	0.360 (9.14)	K, M	N, L, M, J, K
L1X(1)405335(2)(3)12	3.3	4	0.120 (3.05)	K, M	N, L, M, J, K
L1X(1)505335(2)(3)36	3.3	5	0.360 (9.14)	K, M	N, L, M, J, K
L1X(1)405395(2)(3)12	3.9	4	0.120 (3.05)	K, M	N, L, M, J, K
L1X(1)505395(2)(3)36	3.9	5	0.360 (9.14)	K, M	N, L, M, J, K
L1X(1)405475(2)(3)12	4.7	4	0.120 (3.05)	K, M	N, L, M, J, K
L1X(1)505475(2)(3)36	4.7	5	0.360 (9.14)	K, M	N, L, M, J, K
L1X(1)405565(2)(3)24	5.6	4	0.240 (6.10)	K, M	N, L, M, J, K
L1X(1)505565(2)(3)48	5.6	5	0.480 (12.19)	K, M	N, L, M, J, K
L1X(1)405605(2)(3)24	6	4	0.240 (6.10)	K, M	N, L, M, J, K
L1X(1)505605(2)(3)48	6	5	0.480 (12.19)	K, M	N, L, M, J, K
L1X(1)305685(2)(3)12	6.8	3	0.120 (3.05)	K, M	N, L, M, J, K
L1X(1)405685(2)(3)24	6.8	4	0.240 (6.10)	K, M	N, L, M, J, K
L1X(1)505685(2)(3)65	6.8	5	0.650 (16.51)	K, M	N, L, M, J, K
L1X(1)405755(2)(3)24	7.5	4	0.240 (6.10)	K, M	N, L, M, J, K
L1X(1)505755(2)(3)65	7.5	5	0.650 (16.51)	K, M	N, L, M, J, K
L1X(1)305825(2)(3)12	8.2	3	0.120 (3.05)	K, M	N, L, M, J, K
L1X(1)405825(2)(3)24	8.2	4	0.240 (6.10)	K, M	N, L, M, J, K
L1X(1)305106(2)(3)12	10	3	0.120 (3.05)	K, M	N, L, M, J, K
L1X(1)405106(2)(3)24	10	4	0.240 (6.10)	K, M	N, L, M, J, K
L1X(1)305116(2)(3)12	11	3	0.120 (3.05)	K, M	N, L, M, J, K
L1X(1)305126(2)(3)12	12	3	0.120 (3.05)	K, M	N, L, M, J, K
L1X(1)405126(2)(3)36	12	4	0.360 (9.14)	K, M	N, L, M, J, K
L1X(1)305156(2)(3)12	15	3	0.120 (3.05)	K, M	N, L, M, J, K
L1X(1)405156(2)(3)36	15	4	0.360 (9.14)	K, M	N, L, M, J, K
L1X(1)305166(2)(3)24	16	3	0.240 (6.10)	K, M	N, L, M, J, K
L1X(1)405166(2)(3)48	16	4	0.480 (12.19)	K, M	N, L, M, J, K
L1X(1)305186(2)(3)24	18	3	0.240 (6.10)	K, M	N, L, M, J, K
L1X(1)405186(2)(3)48	18	4	0.480 (12.19)	K, M	N, L, M, J, K
L1X(1)305206(2)(3)24	20	3	0.240 (6.10)	K, M	N, L, M, J, K
L1X(1)405206(2)(3)48	20	4	0.480 (12.19)	K, M	N, L, M, J, K
L1X(1)305226(2)(3)24	22	3	0.240 (6.10)	K, M	N, L, M, J, K
L1X(1)405226(2)(3)65	22	4	0.650 (16.51)	K, M	N, L, M, J, K
L1X(1)405246(2)(3)65	24	4	0.650 (16.51)	K, M	N, L, M, J, K
L1X(1)305276(2)(3)24	27	3	0.240 (6.10)	K, M	N, L, M, J, K
L1X(1)305306(2)(3)24	30	3	0.240 (6.10)	K, M	N, L, M, J, K
L1X(1)305336(2)(3)36	33	3	0.360 (9.14)	K, M	N, L, M, J, K
L1X(1)305396(2)(3)36	39	3	0.360 (9.14)	K, M	N, L, M, J, K
L1X(1)305456(2)(3)36	45	3	0.360 (9.14)	K, M	N, L, M, J, K
<b>KEMET P/N <sup>1</sup></b>	<b>Cap (µF)</b>	<b>Case Code</b>	<b>Height A inch (mm)</b>	<b>Cap Tolerance</b>	<b>Lead Config.</b>

<sup>1</sup> Complete part number requires additional characters in the numbered positions provided in order to indicate product level (B level or T level), capacitance tolerance and lead configuration. For each numbered position, available options are as follows:

- (1) Test Level character "S" for Commercial, or "X" for non-standard (customer specific)
- (2) Capacitance tolerance character "K" or "M"
- (3) Lead style character "N", "L", "M", "J" or "K"

**Table 1C – Commercial/Non-Standard – Product Selection 50VDC-100VDC con't.**

<b>Commercial/Non-Standard – Customer Specific Unencapsulated, Horizontally Stacked</b>					
<b>KEMET P/N <sup>1</sup></b>	<b>Cap (µF)</b>	<b>Case Code</b>	<b>Height A inch (mm)</b>	<b>Cap Tolerance</b>	<b>Lead Config.</b>
L1X(1)305506(2)(3)48	50	3	0.480 (12.19)	K, M	N, L, M, J, K
L1X(1)305546(2)(3)48	54	3	0.480 (12.19)	K, M	N, L, M, J, K
L1X(1)305606(2)(3)48	60	3	0.480 (12.19)	K, M	N, L, M, J, K
L1X(1)305666(2)(3)65	66	3	0.650 (16.51)	K, M	N, L, M, J, K
L1X(1)305726(2)(3)65	72	3	0.650 (16.51)	K, M	N, L, M, J, K
L1X(1)305756(2)(3)65	75	3	0.650 (16.51)	K, M	N, L, M, J, K
<b>100VDC - BR Dielectric</b>					
L1R(1)501564(2)(3)12	0.56	5	0.120 (3.05)	K, M	N, L, M, J, K
L1R(1)501684(2)(3)12	0.68	5	0.120 (3.05)	K, M	N, L, M, J, K
L1R(1)501754(2)(3)12	0.75	5	0.120 (3.05)	K, M	N, L, M, J, K
L1R(1)501824(2)(3)12	0.82	5	0.120 (3.05)	K, M	N, L, M, J, K
L1R(1)501105(2)(3)12	1	5	0.120 (3.05)	K, M	N, L, M, J, K
L1R(1)501125(2)(3)12	1.2	5	0.120 (3.05)	K, M	N, L, M, J, K
L1R(1)401155(2)(3)12	1.5	4	0.120 (3.05)	K, M	N, L, M, J, K
L1R(1)501155(2)(3)24	1.5	5	0.240 (6.10)	K, M	N, L, M, J, K
L1R(1)401185(2)(3)12	1.8	4	0.120 (3.05)	K, M	N, L, M, J, K
L1R(1)501185(2)(3)24	1.8	5	0.240 (6.10)	K, M	N, L, M, J, K
L1R(1)401225(2)(3)12	2.2	4	0.120 (3.05)	K, M	N, L, M, J, K
L1R(1)501225(2)(3)24	2.2	5	0.240 (6.10)	K, M	N, L, M, J, K
L1R(1)501255(2)(3)24	2.5	5	0.240 (6.10)	K, M	N, L, M, J, K
L1R(1)401275(2)(3)12	2.7	4	0.120 (3.05)	K, M	N, L, M, J, K
L1R(1)501275(2)(3)36	2.7	5	0.360 (9.14)	K, M	N, L, M, J, K
L1R(1)401335(2)(3)12	3.3	4	0.120 (3.05)	K, M	N, L, M, J, K
L1R(1)501335(2)(3)36	3.3	5	0.360 (9.14)	K, M	N, L, M, J, K
L1R(1)401395(2)(3)12	3.9	4	0.120 (3.05)	K, M	N, L, M, J, K
L1R(1)501395(2)(3)48	3.9	5	0.480 (12.19)	K, M	N, L, M, J, K
L1R(1)401475(2)(3)24	4.7	4	0.240 (6.10)	K, M	N, L, M, J, K
L1R(1)501475(2)(3)48	4.7	5	0.480 (12.19)	K, M	N, L, M, J, K
L1R(1)301565(2)(3)12	5.6	3	0.120 (3.05)	K, M	N, L, M, J, K
L1R(1)401565(2)(3)24	5.6	4	0.240 (6.10)	K, M	N, L, M, J, K
L1R(1)501565(2)(3)65	5.6	5	0.650 (16.51)	K, M	N, L, M, J, K
L1R(1)301605(2)(3)12	6	3	0.120 (3.05)	K, M	N, L, M, J, K
L1R(1)401605(2)(3)24	6	4	0.240 (6.10)	K, M	N, L, M, J, K
L1R(1)501605(2)(3)65	6	5	0.650 (16.51)	K, M	N, L, M, J, K
L1R(1)301685(2)(3)12	6.8	3	0.120 (3.05)	K, M	N, L, M, J, K
L1R(1)401685(2)(3)24	6.8	4	0.240 (6.10)	K, M	N, L, M, J, K
L1R(1)401755(2)(3)24	7.5	4	0.240 (6.10)	K, M	N, L, M, J, K
L1R(1)301825(2)(3)12	8.2	3	0.120 (3.05)	K, M	N, L, M, J, K
L1R(1)401825(2)(3)36	8.2	4	0.360 (9.14)	K, M	N, L, M, J, K
L1R(1)301106(2)(3)12	10	3	0.120 (3.05)	K, M	N, L, M, J, K
L1R(1)401106(2)(3)36	10	4	0.360 (9.14)	K, M	N, L, M, J, K
L1R(1)301116(2)(3)12	11	3	0.120 (3.05)	K, M	N, L, M, J, K
L1R(1)301126(2)(3)24	12	3	0.240 (6.10)	K, M	N, L, M, J, K
L1R(1)401126(2)(3)48	12	4	0.480 (12.19)	K, M	N, L, M, J, K
L1R(1)301156(2)(3)24	15	3	0.240 (6.10)	K, M	N, L, M, J, K
L1R(1)401156(2)(3)48	15	4	0.480 (12.19)	K, M	N, L, M, J, K
L1R(1)301166(2)(3)24	16	3	0.240 (6.10)	K, M	N, L, M, J, K
L1R(1)401166(2)(3)65	16	4	0.650 (16.51)	K, M	N, L, M, J, K
L1R(1)301186(2)(3)24	18	3	0.240 (6.10)	K, M	N, L, M, J, K
L1R(1)401186(2)(3)65	18	4	0.650 (16.51)	K, M	N, L, M, J, K
L1R(1)301206(2)(3)24	20	3	0.240 (6.10)	K, M	N, L, M, J, K
L1R(1)301226(2)(3)36	22	3	0.360 (9.14)	K, M	N, L, M, J, K
L1R(1)301276(2)(3)36	27	3	0.360 (9.14)	K, M	N, L, M, J, K
<b>KEMET P/N <sup>1</sup></b>	<b>Cap (µF)</b>	<b>Case Code</b>	<b>Height A inch (mm)</b>	<b>Cap Tolerance</b>	<b>Lead Config.</b>

<sup>1</sup> Complete part number requires additional characters in the numbered positions provided in order to indicate product level (B level or T level), capacitance tolerance and lead configuration. For each numbered position, available options are as follows:

- (1) Test Level character "S" for Commercial, or "X" for non-standard (customer specific)
- (2) Capacitance tolerance character "K" or "M"
- (3) Lead style character "N", "L", "M", "J" or "K"

**Table 1C – Commercial/Non-Standard – Product Selection 100VDC-200VDC con't.**

<b>Commercial/Non-Standard – Customer Specific Unencapsulated, Horizontally Stacked</b>					
<b>KEMET P/N <sup>1</sup></b>	<b>Cap (µF)</b>	<b>Case Code</b>	<b>Height A inch (mm)</b>	<b>Cap Tolerance</b>	<b>Lead Config.</b>
L1R(1)301306(2)(3)36	30	3	0.360 (9.14)	K, M	N, L, M, J, K
L1R(1)301336(2)(3)48	33	3	0.480 (12.19)	K, M	N, L, M, J, K
L1R(1)301396(2)(3)48	39	3	0.480 (12.19)	K, M	N, L, M, J, K
L1R(1)301456(2)(3)65	45	3	0.650 (16.51)	K, M	N, L, M, J, K
L1R(1)301506(2)(3)65	50	3	0.650 (16.51)	K, M	N, L, M, J, K
<b>200VDC - BQ Dielectric</b>					
L1Q(1)502334(2)(3)12	0.33	5	0.120 (3.05)	K, M	N, L, M, J, K
L1Q(1)502394(2)(3)12	0.39	5	0.120 (3.05)	K, M	N, L, M, J, K
L1Q(1)502474(2)(3)12	0.47	5	0.120 (3.05)	K, M	N, L, M, J, K
L1Q(1)502564(2)(3)12	0.56	5	0.120 (3.05)	K, M	N, L, M, J, K
L1Q(1)502684(2)(3)12	0.68	5	0.120 (3.05)	K, M	N, L, M, J, K
L1Q(1)502754(2)(3)12	0.75	5	0.120 (3.05)	K, M	N, L, M, J, K
L1Q(1)402824(2)(3)12	0.82	4	0.120 (3.05)	K, M	N, L, M, J, K
L1Q(1)502824(2)(3)24	0.82	5	0.240 (6.10)	K, M	N, L, M, J, K
L1Q(1)402105(2)(3)12	1	4	0.120 (3.05)	K, M	N, L, M, J, K
L1Q(1)502105(2)(3)24	1	5	0.240 (6.10)	K, M	N, L, M, J, K
L1Q(1)402125(2)(3)12	1.2	4	0.120 (3.05)	K, M	N, L, M, J, K
L1Q(1)502125(2)(3)24	1.2	5	0.240 (6.10)	K, M	N, L, M, J, K
L1Q(1)402155(2)(3)12	1.5	4	0.120 (3.05)	K, M	N, L, M, J, K
L1Q(1)502155(2)(3)36	1.5	5	0.360 (9.14)	K, M	N, L, M, J, K
L1Q(1)402185(2)(3)12	1.8	4	0.120 (3.05)	K, M	N, L, M, J, K
L1Q(1)502185(2)(3)36	1.8	5	0.360 (9.14)	K, M	N, L, M, J, K
L1Q(1)402225(2)(3)24	2.2	4	0.240 (6.10)	K, M	N, L, M, J, K
L1Q(1)502225(2)(3)48	2.2	5	0.480 (12.19)	K, M	N, L, M, J, K
L1Q(1)302245(2)(3)12	2.4	3	0.120 (3.05)	K, M	N, L, M, J, K
L1Q(1)502255(2)(3)48	2.5	5	0.480 (12.19)	K, M	N, L, M, J, K
L1Q(1)302275(2)(3)12	2.7	3	0.120 (3.05)	K, M	N, L, M, J, K
L1Q(1)402275(2)(3)24	2.7	4	0.240 (6.10)	K, M	N, L, M, J, K
L1Q(1)502275(2)(3)48	2.7	5	0.480 (12.19)	K, M	N, L, M, J, K
L1Q(1)302335(2)(3)12	3.3	3	0.120 (3.05)	K, M	N, L, M, J, K
L1Q(1)402335(2)(3)24	3.3	4	0.240 (6.10)	K, M	N, L, M, J, K
L1Q(1)502335(2)(3)65	3.3	5	0.650 (16.51)	K, M	N, L, M, J, K
L1Q(1)302365(2)(3)12	3.6	3	0.120 (3.05)	K, M	N, L, M, J, K
L1Q(1)302395(2)(3)12	3.9	3	0.120 (3.05)	K, M	N, L, M, J, K
L1Q(1)402395(2)(3)24	3.9	4	0.240 (6.10)	K, M	N, L, M, J, K
L1Q(1)302475(2)(3)12	4.7	3	0.120 (3.05)	K, M	N, L, M, J, K
L1Q(1)402475(2)(3)36	4.7	4	0.360 (9.14)	K, M	N, L, M, J, K
L1Q(1)302565(2)(3)12	5.6	3	0.120 (3.05)	K, M	N, L, M, J, K
L1Q(1)402565(2)(3)36	5.6	4	0.360 (9.14)	K, M	N, L, M, J, K
L1Q(1)302605(2)(3)12	6	3	0.120 (3.05)	K, M	N, L, M, J, K
L1Q(1)402605(2)(3)36	6	4	0.360 (9.14)	K, M	N, L, M, J, K
L1Q(1)302685(2)(3)24	6.8	3	0.240 (6.10)	K, M	N, L, M, J, K
L1Q(1)402685(2)(3)48	6.8	4	0.480 (12.19)	K, M	N, L, M, J, K
L1Q(1)402755(2)(3)48	7.5	4	0.480 (12.19)	K, M	N, L, M, J, K
L1Q(1)302825(2)(3)24	8.2	3	0.240 (6.10)	K, M	N, L, M, J, K
L1Q(1)402825(2)(3)65	8.2	4	0.650 (16.51)	K, M	N, L, M, J, K
L1Q(1)302106(2)(3)24	10	3	0.240 (6.10)	K, M	N, L, M, J, K
L1Q(1)402106(2)(3)65	10	4	0.650 (16.51)	K, M	N, L, M, J, K
L1Q(1)302116(2)(3)24	11	3	0.240 (6.10)	K, M	N, L, M, J, K
L1Q(1)302126(2)(3)36	12	3	0.360 (9.14)	K, M	N, L, M, J, K
L1Q(1)302156(2)(3)36	15	3	0.360 (9.14)	K, M	N, L, M, J, K
L1Q(1)302166(2)(3)36	16	3	0.360 (9.14)	K, M	N, L, M, J, K
L1Q(1)302186(2)(3)48	18	3	0.480 (12.19)	K, M	N, L, M, J, K
<b>KEMET P/N <sup>1</sup></b>	<b>Cap (µF)</b>	<b>Case Code</b>	<b>Height A inch (mm)</b>	<b>Cap Tolerance</b>	<b>Lead Config.</b>

<sup>1</sup> Complete part number requires additional characters in the numbered positions provided in order to indicate product level (B level or T level), capacitance tolerance and lead configuration. For each numbered position, available options are as follows:

- (1) Test Level character "S" for Commercial, or "X" for non-standard (customer specific)
- (2) Capacitance tolerance character "K" or "M"
- (3) Lead style character "N", "L", "M", "J" or "K"



**Table 1C – Commercial/Non-Standard – Product Selection 200VDC-630VDC con't.**

<b>Commercial/Non-Standard – Customer Specific Unencapsulated, Horizontally Stacked</b>					
<b>KEMET P/N <sup>1</sup></b>	<b>Cap (µF)</b>	<b>Case Code</b>	<b>Height A inch (mm)</b>	<b>Cap Tolerance</b>	<b>Lead Config.</b>
L1Q(1)302206(2)(3)48	20	3	0.480 (12.19)	K, M	N, L, M, J, K
L1Q(1)302226(2)(3)48	22	3	0.480 (12.19)	K, M	N, L, M, J, K
L1Q(1)302276(2)(3)65	27	3	0.650 (16.51)	K, M	N, L, M, J, K
<b>500VDC - X7R Dielectric</b>					
L1W(1)50C124(2)(3)12	0.12	5	0.120 (3.05)	K, M	N, L, M, J, K
L1W(1)50C154(2)(3)12	0.15	5	0.120 (3.05)	K, M	N, L, M, J, K
L1W(1)50C184(2)(3)12	0.18	5	0.120 (3.05)	K, M	N, L, M, J, K
L1W(1)50C224(2)(3)12	0.22	5	0.120 (3.05)	K, M	N, L, M, J, K
L1W(1)50C274(2)(3)12	0.27	5	0.120 (3.05)	K, M	N, L, M, J, K
L1W(1)50C334(2)(3)24	0.33	5	0.240 (6.10)	K, M	N, L, M, J, K
L1W(1)40C394(2)(3)12	0.39	4	0.120 (3.05)	K, M	N, L, M, J, K
L1W(1)50C394(2)(3)24	0.39	5	0.240 (6.10)	K, M	N, L, M, J, K
L1W(1)40C474(2)(3)12	0.47	4	0.120 (3.05)	K, M	N, L, M, J, K
L1W(1)50C474(2)(3)24	0.47	5	0.240 (6.10)	K, M	N, L, M, J, K
L1W(1)50C564(2)(3)24	0.56	5	0.240 (6.10)	K, M	N, L, M, J, K
L1W(1)40C684(2)(3)12	0.68	4	0.120 (3.05)	K, M	N, L, M, J, K
L1W(1)50C684(2)(3)36	0.68	5	0.360 (9.14)	K, M	N, L, M, J, K
L1W(1)50C754(2)(3)36	0.75	5	0.360 (9.14)	K, M	N, L, M, J, K
L1W(1)40C824(2)(3)12	0.82	4	0.120 (3.05)	K, M	N, L, M, J, K
L1W(1)50C824(2)(3)36	0.82	5	0.360 (9.14)	K, M	N, L, M, J, K
L1W(1)30C105(2)(3)12	1	3	0.120 (3.05)	K, M	N, L, M, J, K
L1W(1)40C105(2)(3)24	1	4	0.240 (6.10)	K, M	N, L, M, J, K
L1W(1)50C105(2)(3)48	1	5	0.480 (12.19)	K, M	N, L, M, J, K
L1W(1)30C125(2)(3)12	1.2	3	0.120 (3.05)	K, M	N, L, M, J, K
L1W(1)40C125(2)(3)24	1.2	4	0.240 (6.10)	K, M	N, L, M, J, K
L1W(1)50C125(2)(3)65	1.2	5	0.650 (16.51)	K, M	N, L, M, J, K
L1W(1)30C155(2)(3)12	1.5	3	0.120 (3.05)	K, M	N, L, M, J, K
L1W(1)40C155(2)(3)24	1.5	4	0.240 (6.10)	K, M	N, L, M, J, K
L1W(1)50C155(2)(3)65	1.5	5	0.650 (16.51)	K, M	N, L, M, J, K
L1W(1)40C185(2)(3)36	1.8	4	0.360 (9.14)	K, M	N, L, M, J, K
L1W(1)30C225(2)(3)12	2.2	3	0.120 (3.05)	K, M	N, L, M, J, K
L1W(1)40C225(2)(3)36	2.2	4	0.360 (9.14)	K, M	N, L, M, J, K
L1W(1)30C245(2)(3)12	2.4	3	0.120 (3.05)	K, M	N, L, M, J, K
L1W(1)30C275(2)(3)12	2.7	3	0.120 (3.05)	K, M	N, L, M, J, K
L1W(1)40C275(2)(3)48	2.7	4	0.480 (12.19)	K, M	N, L, M, J, K
L1W(1)30C335(2)(3)24	3.3	3	0.240 (6.10)	K, M	N, L, M, J, K
L1W(1)40C335(2)(3)48	3.3	4	0.480 (12.19)	K, M	N, L, M, J, K
L1W(1)30C365(2)(3)24	3.6	3	0.240 (6.10)	K, M	N, L, M, J, K
L1W(1)30C395(2)(3)24	3.9	3	0.240 (6.10)	K, M	N, L, M, J, K
L1W(1)40C395(2)(3)65	3.9	4	0.650 (16.51)	K, M	N, L, M, J, K
L1W(1)30C475(2)(3)24	4.7	3	0.240 (6.10)	K, M	N, L, M, J, K
L1W(1)30C565(2)(3)24	5.6	3	0.240 (6.10)	K, M	N, L, M, J, K
L1W(1)30C605(2)(3)24	6	3	0.240 (6.10)	K, M	N, L, M, J, K
L1W(1)30C685(2)(3)36	6.8	3	0.360 (9.14)	K, M	N, L, M, J, K
L1W(1)30C825(2)(3)36	8.2	3	0.360 (9.14)	K, M	N, L, M, J, K
L1W(1)30C106(2)(3)48	10	3	0.480 (12.19)	K, M	N, L, M, J, K
L1W(1)30C116(2)(3)65	11	3	0.650 (16.51)	K, M	N, L, M, J, K
L1W(1)30C126(2)(3)65	12	3	0.650 (16.51)	K, M	N, L, M, J, K
<b>630VDC - X7R Dielectric</b>					
L1W(1)50B683(2)(3)12	0.068	5	0.120 (3.05)	K, M	N, L, M, J, K
L1W(1)40B104(2)(3)12	0.1	4	0.120 (3.05)	K, M	N, L, M, J, K
L1W(1)50B104(2)(3)12	0.1	5	0.120 (3.05)	K, M	N, L, M, J, K
<b>KEMET P/N <sup>1</sup></b>	<b>Cap (µF)</b>	<b>Case Code</b>	<b>Height A inch (mm)</b>	<b>Cap Tolerance</b>	<b>Lead Config.</b>

<sup>1</sup> Complete part number requires additional characters in the numbered positions provided in order to indicate product level (B level or T level), capacitance tolerance and lead configuration. For each numbered position, available options are as follows:

- (1) Test Level character "S" for Commercial, or "X" for non-standard (customer specific)
- (2) Capacitance tolerance character "K" or "M"
- (3) Lead style character "N", "L", "M", "J" or "K"

**Table 1C – Commercial/Non-Standard – Product Selection 630VDC-1000VDC con't.**

<b>Commercial/Non-Standard – Customer Specific Unencapsulated, Horizontally Stacked</b>					
<b>KEMET P/N <sup>1</sup></b>	<b>Cap (µF)</b>	<b>Case Code</b>	<b>Height A inch (mm)</b>	<b>Cap Tolerance</b>	<b>Lead Config.</b>
L1W(1)50B124(2)(3)12	0.12	5	0.120 (3.05)	K, M	N, L, M, J, K
L1W(1)50B154(2)(3)12	0.15	5	0.120 (3.05)	K, M	N, L, M, J, K
L1W(1)50B184(2)(3)24	0.18	5	0.240 (6.10)	K, M	N, L, M, J, K
L1W(1)30B224(2)(3)12	0.22	3	0.120 (3.05)	K, M	N, L, M, J, K
L1W(1)40B224(2)(3)12	0.22	4	0.120 (3.05)	K, M	N, L, M, J, K
L1W(1)50B224(2)(3)24	0.22	5	0.240 (6.10)	K, M	N, L, M, J, K
L1W(1)50B274(2)(3)24	0.27	5	0.240 (6.10)	K, M	N, L, M, J, K
L1W(1)30B334(2)(3)12	0.33	3	0.120 (3.05)	K, M	N, L, M, J, K
L1W(1)50B334(2)(3)36	0.33	5	0.360 (9.14)	K, M	N, L, M, J, K
L1W(1)40B394(2)(3)12	0.39	4	0.120 (3.05)	K, M	N, L, M, J, K
L1W(1)50B394(2)(3)36	0.39	5	0.360 (9.14)	K, M	N, L, M, J, K
L1W(1)30B474(2)(3)12	0.47	3	0.120 (3.05)	K, M	N, L, M, J, K
L1W(1)40B474(2)(3)24	0.47	4	0.240 (6.10)	K, M	N, L, M, J, K
L1W(1)50B474(2)(3)36	0.47	5	0.360 (9.14)	K, M	N, L, M, J, K
L1W(1)50B564(2)(3)48	0.56	5	0.480 (12.19)	K, M	N, L, M, J, K
L1W(1)30B684(2)(3)12	0.68	3	0.120 (3.05)	K, M	N, L, M, J, K
L1W(1)40B684(2)(3)24	0.68	4	0.240 (6.10)	K, M	N, L, M, J, K
L1W(1)50B684(2)(3)65	0.68	5	0.650 (16.51)	K, M	N, L, M, J, K
L1W(1)50B754(2)(3)65	0.75	5	0.650 (16.51)	K, M	N, L, M, J, K
L1W(1)40B824(2)(3)24	0.82	4	0.240 (6.10)	K, M	N, L, M, J, K
L1W(1)30B105(2)(3)12	1	3	0.120 (3.05)	K, M	N, L, M, J, K
L1W(1)40B105(2)(3)36	1	4	0.360 (9.14)	K, M	N, L, M, J, K
L1W(1)30B125(2)(3)12	1.2	3	0.120 (3.05)	K, M	N, L, M, J, K
L1W(1)40B125(2)(3)36	1.2	4	0.360 (9.14)	K, M	N, L, M, J, K
L1W(1)30B155(2)(3)12	1.5	3	0.120 (3.05)	K, M	N, L, M, J, K
L1W(1)40B155(2)(3)48	1.5	4	0.480 (12.19)	K, M	N, L, M, J, K
L1W(1)40B185(2)(3)48	1.8	4	0.480 (12.19)	K, M	N, L, M, J, K
L1W(1)30B225(2)(3)24	2.2	3	0.240 (6.10)	K, M	N, L, M, J, K
L1W(1)40B225(2)(3)65	2.2	4	0.650 (16.51)	K, M	N, L, M, J, K
L1W(1)30B245(2)(3)24	2.4	3	0.240 (6.10)	K, M	N, L, M, J, K
L1W(1)30B275(2)(3)24	2.7	3	0.240 (6.10)	K, M	N, L, M, J, K
L1W(1)30B335(2)(3)36	3.3	3	0.360 (9.14)	K, M	N, L, M, J, K
L1W(1)30B365(2)(3)36	3.6	3	0.360 (9.14)	K, M	N, L, M, J, K
L1W(1)30B395(2)(3)36	3.9	3	0.360 (9.14)	K, M	N, L, M, J, K
L1W(1)30B475(2)(3)36	4.7	3	0.360 (9.14)	K, M	N, L, M, J, K
L1W(1)30B565(2)(3)48	5.6	3	0.480 (12.19)	K, M	N, L, M, J, K
L1W(1)30B605(2)(3)65	6	3	0.650 (16.51)	K, M	N, L, M, J, K
L1W(1)30B685(2)(3)65	6.8	3	0.650 (16.51)	K, M	N, L, M, J, K
<b>1000VDC - X7R Dielectric</b>					
L1W(1)50D473(2)(3)12	0.047	5	0.120 (3.05)	K, M	N, L, M, J, K
L1W(1)50D683(2)(3)12	0.068	5	0.120 (3.05)	K, M	N, L, M, J, K
L1W(1)30D104(2)(3)12	0.1	3	0.120 (3.05)	K, M	N, L, M, J, K
L1W(1)40D104(2)(3)12	0.1	4	0.120 (3.05)	K, M	N, L, M, J, K
L1W(1)50D104(2)(3)24	0.1	5	0.240 (6.10)	K, M	N, L, M, J, K
L1W(1)50D124(2)(3)24	0.12	5	0.240 (6.10)	K, M	N, L, M, J, K
L1W(1)50D154(2)(3)36	0.15	5	0.360 (9.14)	K, M	N, L, M, J, K
L1W(1)50D184(2)(3)36	0.18	5	0.360 (9.14)	K, M	N, L, M, J, K
L1W(1)30D224(2)(3)12	0.22	3	0.120 (3.05)	K, M	N, L, M, J, K
L1W(1)40D224(2)(3)12	0.22	4	0.120 (3.05)	K, M	N, L, M, J, K
L1W(1)50D224(2)(3)36	0.22	5	0.360 (9.14)	K, M	N, L, M, J, K
L1W(1)50D274(2)(3)48	0.27	5	0.480 (12.19)	K, M	N, L, M, J, K
L1W(1)30D334(2)(3)12	0.33	3	0.120 (3.05)	K, M	N, L, M, J, K
L1W(1)50D334(2)(3)65	0.33	5	0.650 (16.51)	K, M	N, L, M, J, K
<b>KEMET P/N <sup>1</sup></b>	<b>Cap (µF)</b>	<b>Case Code</b>	<b>Height A inch (mm)</b>	<b>Cap Tolerance</b>	<b>Lead Config.</b>

<sup>1</sup> Complete part number requires additional characters in the numbered positions provided in order to indicate product level (B level or T level), capacitance tolerance and lead configuration. For each numbered position, available options are as follows:

- (1) Test Level character "S" for Commercial, or "X" for non-standard (customer specific)
- (2) Capacitance tolerance character "K" or "M"
- (3) Lead style character "N", "L", "M", "J" or "K"

**Table 1C – Commercial/Non-Standard – Product Selection 1000VDC con't.**

<b>Commercial/Non-Standard – Customer Specific Unencapsulated, Horizontally Stacked</b>					
<b>KEMET P/N <sup>1</sup></b>	<b>Cap (μF)</b>	<b>Case Code</b>	<b>Height A inch (mm)</b>	<b>Cap Tolerance</b>	<b>Lead Config.</b>
L1W(1)40D394(2)(3)24	0.39	4	0.240 (6.10)	K, M	N, L, M, J, K
L1W(1)50D394(2)(3)65	0.39	5	0.650 (16.51)	K, M	N, L, M, J, K
L1W(1)30D474(2)(3)12	0.47	3	0.120 (3.05)	K, M	N, L, M, J, K
L1W(1)40D474(2)(3)24	0.47	4	0.240 (6.10)	K, M	N, L, M, J, K
L1W(1)30D684(2)(3)12	0.68	3	0.120 (3.05)	K, M	N, L, M, J, K
L1W(1)40D684(2)(3)36	0.68	4	0.360 (9.14)	K, M	N, L, M, J, K
L1W(1)40D824(2)(3)48	0.82	4	0.480 (12.19)	K, M	N, L, M, J, K
L1W(1)30D105(2)(3)24	1	3	0.240 (6.10)	K, M	N, L, M, J, K
L1W(1)40D105(2)(3)65	1	4	0.650 (16.51)	K, M	N, L, M, J, K
L1W(1)30D125(2)(3)24	1.2	3	0.240 (6.10)	K, M	N, L, M, J, K
L1W(1)30D155(2)(3)36	1.5	3	0.360 (9.14)	K, M	N, L, M, J, K
L1W(1)30D225(2)(3)36	2.2	3	0.360 (9.14)	K, M	N, L, M, J, K
L1W(1)30D245(2)(3)48	2.4	3	0.480 (12.19)	K, M	N, L, M, J, K
L1W(1)30D275(2)(3)48	2.7	3	0.480 (12.19)	K, M	N, L, M, J, K
L1W(1)30D335(2)(3)65	3.3	3	0.650 (16.51)	K, M	N, L, M, J, K
<b>KEMET P/N <sup>1</sup></b>	<b>Cap (μF)</b>	<b>Case Code</b>	<b>Height A inch (mm)</b>	<b>Cap Tolerance</b>	<b>Lead Config.</b>

<sup>1</sup> Complete part number requires additional characters in the numbered positions provided in order to indicate product level (B level or T level), capacitance tolerance and lead configuration. For each numbered position, available options are as follows:

- (1) Test Level character "S" for Commercial, or "X" for non-standard (customer specific)
- (2) Capacitance tolerance character "K" or "M"
- (3) Lead style character "N", "L", "M", "J" or "K"

## Soldering Process

The capacitors and assemblies outlined in this specification sheet are susceptible to thermal shock damage due to their large ceramic mass. Temperature profiles used should provide adequate temperature rise and cool-down time to prevent damage from thermal shock. In general, KEMET recommends against hand soldering for these types of large ceramic devices.

Recommended Soldering Technique:

- Solder reflow only

Recommended Reflow Soldering Profile:

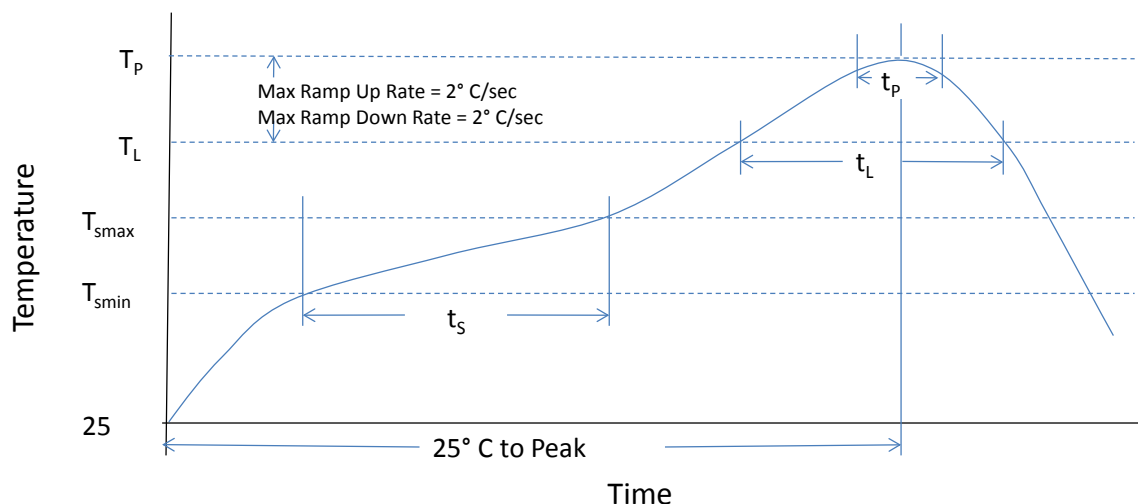

Profile Feature	Sn-Pb Assembly
<b>Preheat/Soak</b>	
Temperature Min ( $T_{smin}$ )	100°C
Temperature Max ( $T_{smax}$ )	150°C
Time ( $t_s$ ) from $T_{smin}$ to $T_{smax}$	60-90 sec
Ramp-up rate ( $T_L$ to $T_p$ )	2°C/sec
Liquidous temperature ( $T_L$ )	183°C
Time above liquidous ( $t_L$ )	95 sec
Peak Temperature ( $T_p$ )	240°C
Time within 5° C of max peak temperature ( $t_p$ )	5 sec
Ramp-down rate ( $T_p$ to $T_L$ )	2°C/sec
Time 25° C to peak temperature	3.5 minutes

Note 1: All temperatures refer to the center of the package, measured on the package body surface that is facing up during assembly reflow

Preheating and Reflow Profile Notes:

Due to differences in the coefficient of thermal expansion for the different materials of construction, it is critical to monitor and control the heating and cooling rates during the soldering process. During the reflow soldering process, the maximum recommended heating and cooling rate ( $dT/dt$ ) is 4°C/second. To ensure optimal component reliability, KEMET's recommended heating and cooling rate is 2°C/second. After soldering, the capacitors should be air cooled to room temperature before further processing. Forced air cooling is not recommended.

**Table 4 – Performance & Reliability: Test Methods and Conditions**

Inspection	Test Method	Test Level Option				
		MIL-PRF-49470 B Level (B)	MIL-PRF-49470 T Level (T)	DSSC Drawing 87106 (C) <sup>1</sup>	Commercial (S)	Non-Standard (X) <sup>2</sup>
<b>In-Process Inspection</b>						
Ultrasonic Scanning (C-SAM)	Meet EIA-469 Criteria	Not required	Yes (per lot)	Not required	Not required	Optional per Source Controlled Drawing (SCD)
DPA Analysis	EIA-469					
In-Process Visual Inspection	MIL-PRF-49470 Method 4.8.3					
<b>Group A Requirements</b>						
Thermal Shock	MIL-STD-202 Method 107	Yes (5 cycles)	Yes (20 cycles)	Yes (5 cycles)	Not required	Optional per Source Controlled Drawing (SCD)
Voltage Conditioning ≤200V 500V	MIL-PRF-49470 Method 4.8.5.2 200%Vr @125°C 120%Vr @125°C	Yes (96 hrs min.)	Yes (168 hrs min.)	Yes (96 hrs min.)		
Visual and Mechanical Inspection	MIL-PRF-49470 Method 4.8.4	Yes (per lot)	Yes (per lot)	Yes (per lot)		Yes (per lot)
Solderability	MIL-STD-202 Method 208	Yes (per Inspection lot)		Yes (per inspection lot)		Optional per Source Controlled Drawing (SCD)
DPA Analysis	EIA-469	Not required		Not required		
<b>Group B Requirements</b>						
Voltage-Temperature Limits (TCVC)	MIL-PRF-49470 Method 4.8.13.2	Yes (periodic)	Yes (per lot)	Yes (periodic)	Not required	Optional per Source Controlled Drawing (SCD)
Resistance to Solvents	MIL-STD-202 Method 215					
Terminal Strength	MIL-STD-202 Method 211					
Resistance to Soldering Heat	MIL-STD-202 Method 210					
Moisture Resistance	MIL-STD-202 Method 106					
Marking Legibility	MIL-PRF-49470 Method 4.8.4.1	Not required	Yes (periodic)	Yes (periodic)		
Low Voltage Humidity Testing	MIL-STD-202 Method 103					
Life Test ≤200V 500V	MIL-STD-202 Method 108 200%Vr @125°C 120%Vr @125°C					
Thermal Shock	MIL-STD-202 Method 107	Not required		Not required		
<b>KEMET Requirements</b>						
Visual and Mechanical Inspection (100%)	KEMET Standard	Yes	Yes	Yes	Yes	Yes
Voltage Conditioning						

<sup>1</sup> As per discretionary statement outlined in cancelled DSSC Drawing 87106, KEMET will not perform Group B inspections on a per lot basis. KEMET 87106 orders may include a standard certificate of compliance stating compliance to the 87106 requirements, specifically conformance to Group B inspections. Please contact KEMET for additional details

<sup>2</sup> Non-standard test level option is designated to satisfy customer specific testing requirements that may deviate from those stated in a Mil-Spec or DSSC drawing.

## Product Marking

Capacitors shall be marked with KEMET's name, trademark or (CAGE) code, date, capacitance and capacitance tolerance codes. The date code shall consist of the year and week. For example, the third week of 2011 would be 1103 using a 4-digit date code or 103 using a 3-digit date code. At the option of the manufacturer, the date code may be placed on a separate line. Full marking shall be included on the package.

JT 12345 106K 1103
-----------------------------

Case code 4 or 5 example

### MIL-PRF-49470

Capacitor marking will include "JAN" or "J."

Case codes 4 and 5 shall be marked with the following sequence of information:

J brand (1 digit), product level designator ("B" or "T")

Manufacturer's identification (1 to 5 digits)

Capacitance code (3 digits) and capacitance tolerance (1 digit)

Date code (3 or 4 digits)

Case code 3 shall either be fully marked or partially marked like case code 4 or 5 parts at the option of KEMET.

### DSCC 87106

Marking shall be in accordance with MIL-STD-1285, except the parts shall be marked with the part number as specified in paragraph 1.2 of DSCC Drawing 87106 with the manufacturer's name or code and date code minimum. Case sizes 4 and 5 shall be marked with coded capacitance and tolerance minimum. Full marking shall be included on the package.

## Storage and Handling

Ceramic chip capacitors should be stored in normal working environments. While the chips themselves are quite robust in other environments, solderability will be degraded by exposure to high temperatures, high humidity, corrosive atmospheres, and long term storage. In addition, packaging materials will be degraded by high temperature – reels may soften or warp, and tape peel force may increase. KEMET recommends that maximum storage temperature not exceed 40 degrees C, and maximum storage humidity not exceed 70% relative humidity. In addition, temperature fluctuations should be minimized to avoid condensation on the parts, and atmospheres should be free of chlorine and sulfur bearing compounds. For optimized solderability, chip stock should be used promptly, preferably within 1.5 years of receipt.

## Packaging

Shipping Container Packaging Quantities		
Case Code	Small Box Quantity <sup>1</sup> (7.5" x 7.5")	Large Box Quantity <sup>1</sup> (13.0" x 13.0")
3	28	104
4	36	144
5	64	225

<sup>1</sup> Minimum order value applies. Contact KEMET for details.

## Application Notes

### Notice of KEMET MIL-PRF-49470 Qualified Products Listing (QPL) Status.

*KEMET is qualified to supply MIL-PRF-49470/1 unencapsulated X7R Case Codes 3, 4, & 5 ceramic SMPS capacitors in DC voltage ratings of 50V, 100V, 200V, and 500V. This qualification includes both "B" and "T" test levels.*

*KEMET is also qualified to supply MIL-PRF-49470/2 encapsulated X7R Case Codes 3, 4, & 5 ceramic SMPS capacitors in DC voltage ratings of 50V, 100V, 200V, and 500V. This qualification includes "B" level testing only.*

### Notice of Cancellation: DSCC Drawing 87106 was cancelled on January 3rd 2005.

#### **MIL-PRF-49470 parts are preferred and direct replacements.**

*MIL-PRF-49470 capacitors are preferred over DSCC 87106 capacitors. The MIL-PRF-49470 specification was developed as part of a cooperative effort between the U.S. Military, NASA and the switch mode power supply capacitor manufacturers to produce a robust direct replacement for the DSCC drawing. The military specification product provides additional quality assurance provisions that are NOT required by the DSCC drawing. Two product levels are offered in MIL-PRF-49470: the standard "B" level and the high reliability "T" level. Some of the benefits of the MIL-PRF-49470 product over the 87106 product include the following: Formal qualification process (QPL established), MIL-STD-790 compliance, DSCC audits, routine qualification maintenance testing, i.e., life testing, group A percent defective allowed (PDA) specified, and prohibiting the mixing of chips from different production lots within a single SMPS capacitor stack lot.*

*MIL-PRF-49470 "T" Level product is recommended for all high reliability applications. MIL-PRF-49470 "T" level product requires the following in-process inspections and additional group A and B screening inspections that are not part of the normal "B" level flow: In-process screening that includes non-destructive internal examination (chip level) and destructive physical analysis (chip level), group A destructive physical analysis (finished stack level), group B lot specific humidity, steady-state, low voltage (lot sample test), and group B lot specific thermal shock & life test (lot sample test).*

*For additional information regarding KEMET MIL-PRF-49470 QPL status or cancellation of DSCC Drawing 87106, please visit the DSCC website at: [www.dscc.dla.mil](http://www.dscc.dla.mil).*

## Other KEMET Resources

Tools	
Resource	Location
Configure A Part: CapEdge	<a href="http://capacitoredge.kemet.com">http://capacitoredge.kemet.com</a>
SPICE & FIT Software	<a href="http://www.kemet.com/spice">http://www.kemet.com/spice</a>
Search Our FAQs: KnowledgeEdge	<a href="http://www.kemet.com/keask">http://www.kemet.com/keask</a>

Product Information	
Resource	Location
Products	<a href="http://www.kemet.com/products">http://www.kemet.com/products</a>
Technical Resources (Including Soldering Techniques)	<a href="http://www.kemet.com/technicalpapers">http://www.kemet.com/technicalpapers</a>
RoHS Statement	<a href="http://www.kemet.com/rohs">http://www.kemet.com/rohs</a>
Quality Documents	<a href="http://www.kemet.com/qualitydocuments">http://www.kemet.com/qualitydocuments</a>

Product Request	
Resource	Location
Sample Request	<a href="http://www.kemet.com/sample">http://www.kemet.com/sample</a>
Engineering Kit Request	<a href="http://www.kemet.com/kits">http://www.kemet.com/kits</a>

Contact	
Resource	Location
Website	<a href="http://www.kemet.com">www.kemet.com</a>
Contact Us	<a href="http://www.kemet.com/contact">http://www.kemet.com/contact</a>
Investor Relations	<a href="http://www.kemet.com/ir">http://www.kemet.com/ir</a>
Call Us	1-877-MyKEMET
Twitter	<a href="http://twitter.com/kemetcapacitors">http://twitter.com/kemetcapacitors</a>

## Disclaimer

All product specifications, statements, information and data (collectively, the "Information") are subject to change without notice.

All Information given herein is believed to be accurate and reliable, but is presented without guarantee, warranty, or responsibility of any kind, expressed or implied.

Statements of suitability for certain applications are based on our knowledge of typical operating conditions for such applications, but are not intended to constitute – and we specifically disclaim – any warranty concerning suitability for a specific customer application or use. This Information is intended for use only by customers who have the requisite experience and capability to determine the correct products for their application. Any technical advice inferred from this Information or otherwise provided by us with reference to the use of our products is given gratis, and we assume no obligation or liability for the advice given or results obtained.

Although we design and manufacture our products to the most stringent quality and safety standards, given the current state of the art, isolated component failures may still occur. Accordingly, customer applications which require a high degree of reliability or safety should employ suitable designs or other safeguards (such as installation of protective circuitry or redundancies) in order to ensure that the failure of an electrical component does not result in a risk of personal injury or property damage.

Although all product-related warnings, cautions and notes must be observed, the customer should not assume that all safety measures are indicated or that other measures may not be required.



## KEMET Corporation World Headquarters

2835 KEMET Way  
Simpsonville, SC 29681

Mailing Address:  
P.O. Box 5928  
Greenville, SC 29606

www.kemet.com  
Tel: 864-963-6300  
Fax: 864-963-6521

### Corporate Offices

Fort Lauderdale, FL  
Tel: 954-766-2800

## North America

### Southeast

Lake Mary, FL  
Tel: 407-855-8886

### Northeast

Wilmington, MA  
Tel: 978-658-1663

West Chester, PA  
Tel: 610-692-4642

### Central

Schaumburg, IL  
Tel: 847-882-3590

Carmel, IN  
Tel: 317-706-6742

### West

Milpitas, CA  
Tel: 408-433-9950

### Mexico

Zapopan, Jalisco  
Tel: 52-33-3123-2141

## Europe

### Southern Europe

Geneva, Switzerland  
Tel: 41-22-715-0100

Paris, France  
Tel: 33-1-4646-1009

Sasso Marconi, Italy  
Tel: 39-051-939111

Milan, Italy  
Tel: 39-02-57518176

Rome, Italy  
Tel: 39-06-23231718

Madrid, Spain  
Tel: 34-91-804-4303

### Central Europe

Landsberg, Germany  
Tel: 49-8191-3350800

Dortmund, Germany  
Tel: 49-2307-3619672

Kwidzyn, Poland  
Tel: 48-55-279-7025

### Northern Europe

Bishop's Stortford, United Kingdom  
Tel: 44-1279-757201

Weymouth, United Kingdom  
Tel: 44-1305-830747

Coatbridge, Scotland  
Tel: 44-1236-434455

Färjestaden, Sweden  
Tel: 46-485-563934

Espoo, Finland  
Tel: 358-9-5406-5000

## Asia

### Northeast Asia

Hong Kong  
Tel: 852-2305-1168

Shenzhen, China  
Tel: 86-755-2518-1306

Beijing, China  
Tel: 86-10-5829-1711

Shanghai, China  
Tel: 86-21-6447-0707

Taipei, Taiwan  
Tel: 886-2-27528585

### Southeast Asia

Singapore  
Tel: 65-6586-1900

Penang, Malaysia  
Tel: 60-4-6430200

Bangalore, India  
Tel: 91-806-53-76817

*Note: KEMET reserves the right to modify minor details of internal and external construction at any time in the interest of product improvement. KEMET does not assume any responsibility for infringement that might result from the use of KEMET Capacitors in potential circuit designs. KEMET is a registered trademark of KEMET Electronics Corporation.*