

L-Series Circuit Breaker

Available with Current Transformer

The L-Series high performance, compact hydraulic-magnetic circuit breaker is ideally suited for the rigors and confined spaces found in today's telecom/datacom power distribution units and rack systems. It provides best in class performance in an innovative low profile, space saving package complementing the overall spatial objectives required by telecommunications and data-communications systems designers in their quest to reduce the overall size of equipment, while increasing transmission capacity.

The optional current transformer allows outlet metering and monitoring of power usage thus facilitating load adjustments and maximizing efficiency. Further, a patent pending flush rocker actuator design and optional push-to-reset guard offers additional protection against accidental switching.

Number of poles: 1-3. Maximum current and voltage ratings: .2-32A, 120/240-240VAC. Maximum interrupting capacity: 5000 Amps

Applications:

- ♦ Telecom/Datacom Industry
 - Power Distribution Units
 - Data Servers
 - Data Storage



Product Highlights:

- ♦ Optional current transformer
- ♦ Ultra low profile design saves valuable space
- ♦ Optional handle guard actuator
- ♦ UL 489 LISTED Branch Circuit breaker
- ♦ Designed for worldwide datacenter compatibility with up to 240VAC ratings



Carling Technologies™

Innovative Designs. Powerful Solutions.

Carling Technologies, Inc.
60 Johnson Avenue • Plainville, CT 06062
Phone: (860) 793-9281 • Fax: (860) 793-9231
Email: sales@carlingtech.com • www.carlingtech.com

L-Series Circuit Breaker

DESIGN FEATURES

1-Pole Configuration with Low Profile Rocker Actuator

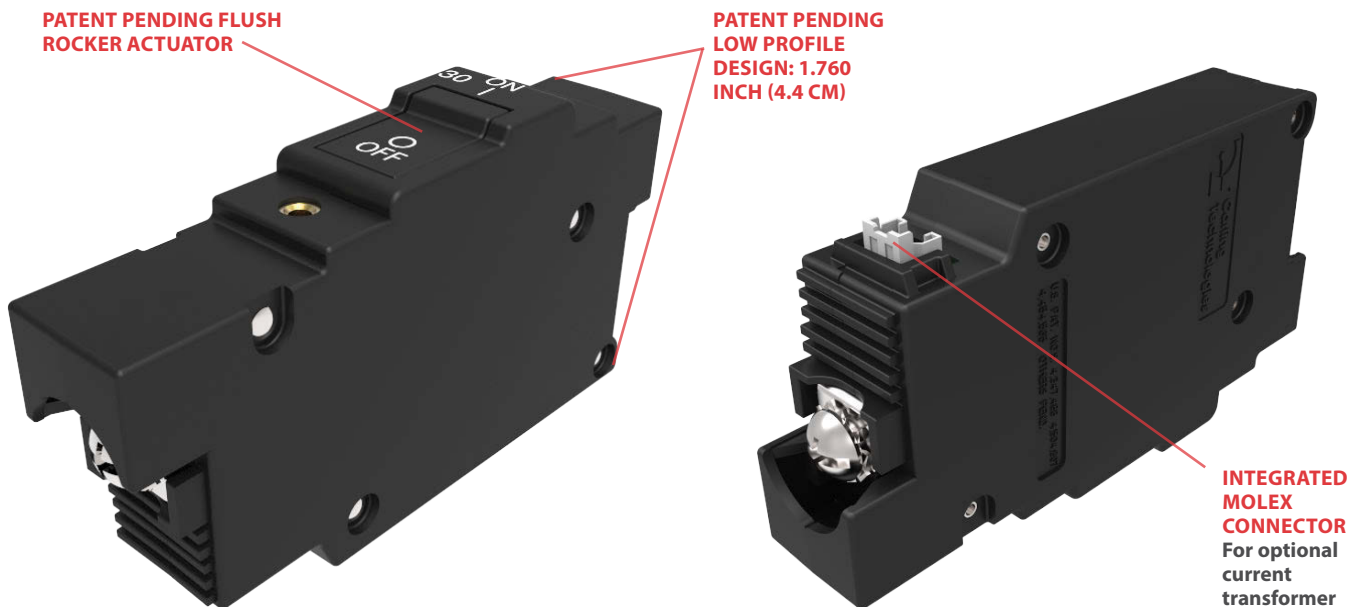

2-Pole Configuration with Push-To-Reset Guard

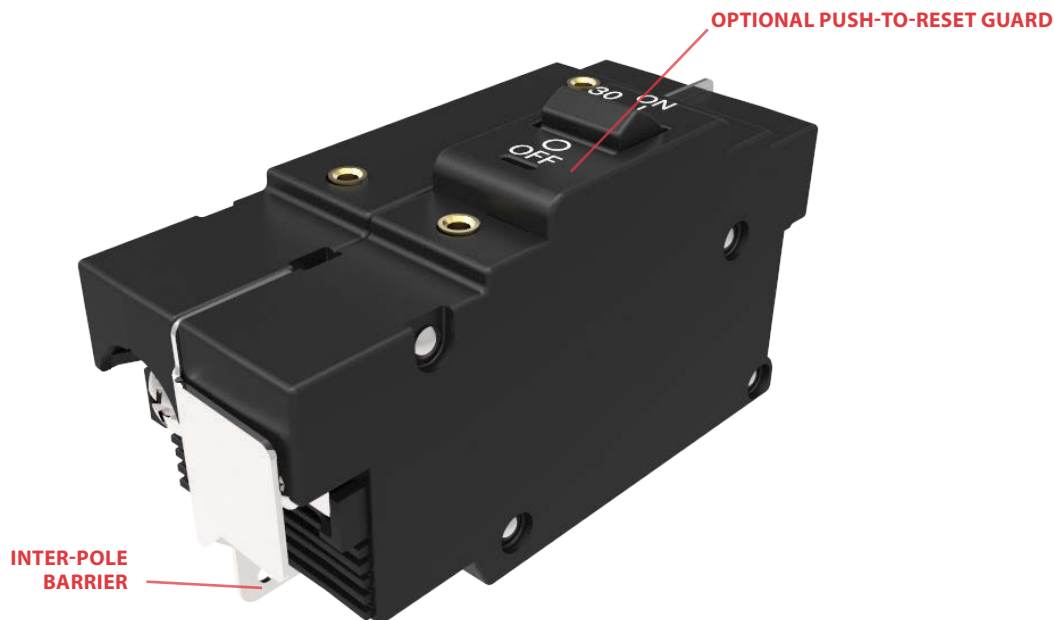

Electrical Tables

Voltage, Current and IC Ratings

Voltage (VAC)	Current (A)	Number of Poles	Current Metering	Interrupt Capacity (Amps)		
				UL489	EN60934	
					Icn	Inc
240	0.1 - 32	1	Yes	5000	3000	10000
240	0.1 - 32	2*	Yes	5000	3000	10000
120/240	0.1 - 32	2	Yes	5000	N/A	N/A
120/240	0.1 - 32	3**	Yes	5000	N/A	N/A

Notes:

* Breaking both sides of the line

** 3rd pole to be neutral break

Time Delay

Delay Curve Number	Voltage	Description
21	50/60 Hz	Ultrashort
22	50/60 Hz	Short
24	50/60 Hz	Medium
26	50/60 Hz	Long
42	50/60 Hz	Hi-inrush, Short
44	50/60 Hz	Hi-inrush, Medium
46	50/60 Hz	Hi-inrush, Long

Impedance

RESISTANCE, IMPEDANCE VALUES
from Line to Load Terminals
(Values Based on Series Trip Circuit Breaker)

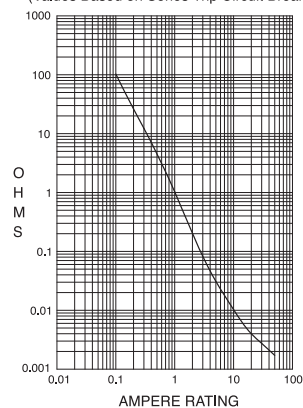

Current (amps)	Tolerance (%)
0.1-5.0	+/-15
5.1-32.0	+/-25

*Manufacturer reserves the right to change product specification without prior notice.

Electrical

Current Metering

Integrated current transformer.
 Measurement range: 1-32 Amps
 Voltage output: 10mV per Amp
 according to the formula below:
 $2(\text{Amp}) \leq I \leq 32(\text{Amp})$

$$V = 0.01 \times I \pm 2\%$$

$$\left| \frac{\frac{V - V_{10}}{I - I_{10}}}{\frac{V_{10}}{I_{10}}} \right| \leq 0.85\%$$

Where V=CT output in volts V10=CT output in volts with I=I10=10 (A); I=primary current in amperage (50/60 Hz). Phase shift between primary current and CT output is $0.25 \pm 0.25^\circ$. Maximum crest factor of primary current is 1.73.

R1 shall be integrated in the breaker. R2 and R3 are provided by end user and external to the breaker. Connection: below Load Terminal. 2-pin connector, Molex 35362-0250. Mating Connector housing – Molex PN35507-0200. Dielectric Strength UL, CSA-1960V 50/60 Hz for one minute between all electrically isolated terminals. Comply with the 8mm spacing and 3750V 50/60 Hz dielectric requirements from hazardous voltage to operator accessible surfaces and between main circuits of adjacent poles per Publications EN 60950 and VDE 0805

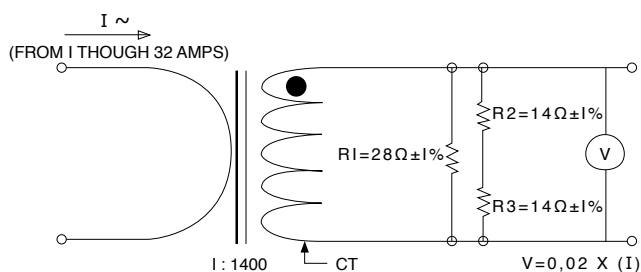

Insulation Resistance

Minimum of 100 Megohms@500VDC

Overload

50 operations @ 600% of rated

Interrupt Capacity

See Table 1

Environmental

Environmental

MIL-PRF-55629 and MIL-STD-202G
 -40°C to +85 °C

Operating Temp

Vibration

Withstands 0.06" excursion from 10-55 Hz and 10Gs 55-500 Hz at rated current per MIL-PRF-55629 and MIL-STD-202G, Method 204D, Test Condition A. Instantaneous and ultra-short curves tested at 90% of rated current.

Shock

Withstands 100 Gs, 6 ms saw tooth while carrying rated current per MIL-PRF-55629 and MIL-STD-202G, Method 213B, Test Condition "I". Instantaneous and ultra short curves tested at 90% of rated current.

Thermal Shock

MIL-PRF-55629 and MIL-STD-202G, Method 107G, Condition A (5-cycles at -55°C to +25°C to +85°C to +25°C).

Moisture Resistance

MIL-PRF-55629 and MIL-STD-202G, Method 106G, i.e., Ten 24-hour cycles at +25°C to +65°C, 80-98% RH.

Salt Spray

Method 101, Condition A (90-95% RH @ 5% NaCl Solution, 96hrs)

Physical

Number of Poles

1-3 poles

Termination

Screw Terminals with the following thread sizes: 10-32, 8-32, M5, M4 Standard for 2 & 3 poles

Termination Barrier

Threaded Insert: #6-32 UNC-2B, or M3X0.5-6H B ISO (2 per Pole)

Mounting

Rocker, with or without guard Series Trip

Actuator

Housing - Glass Filled Polyester

Internal Circuit Config.

Rocker - Nylon 6/6

Materials

Line/Load Terminals – Copper Alloy; Bright Acid Tin Plated

Weight

~107 Grams (~3.76 Ounces) per pole

Standard Color

Housing - Black, Rocker - Black

Mechanical

Endurance

10,000 "On-Off" Operations @ 6 per minute; 6000 cycles with rated Current and Voltage; 4000 cycles without electrical load.

Trip Free

Trips on overload even when actuator is forcibly held in the "On" position.

Trip Indication

The operating actuator moves positively to the "Off" position when an overload causes the breaker to trip

*Manufacturer reserves the right to change product specification without prior notice.

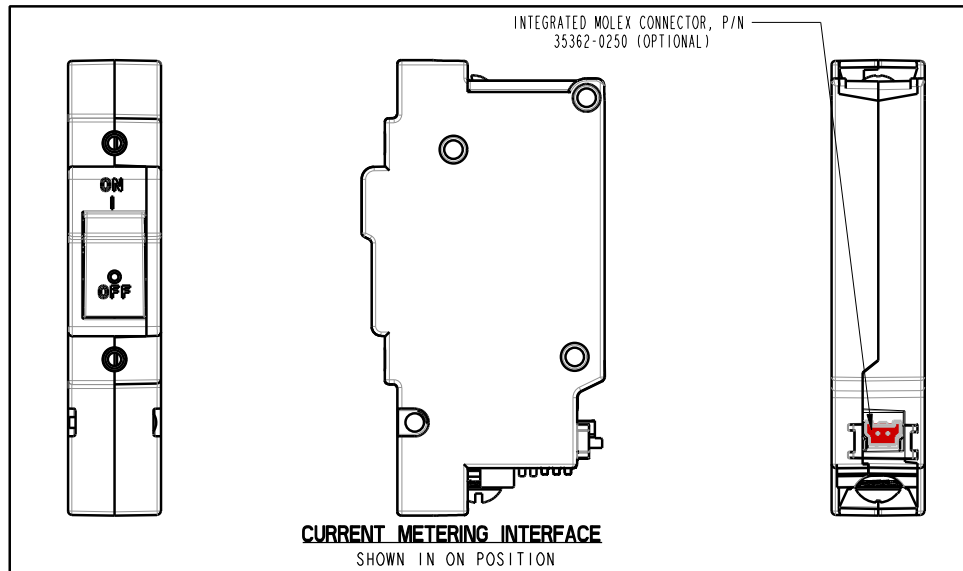
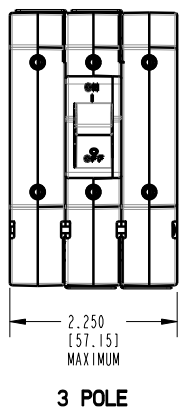
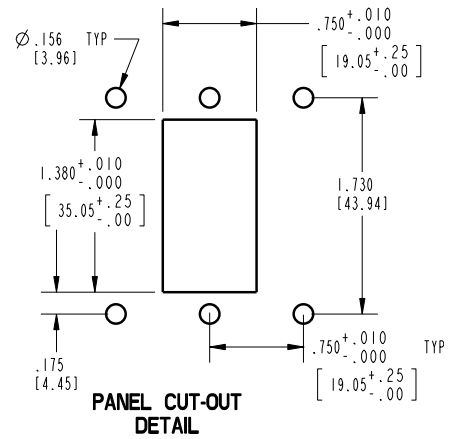
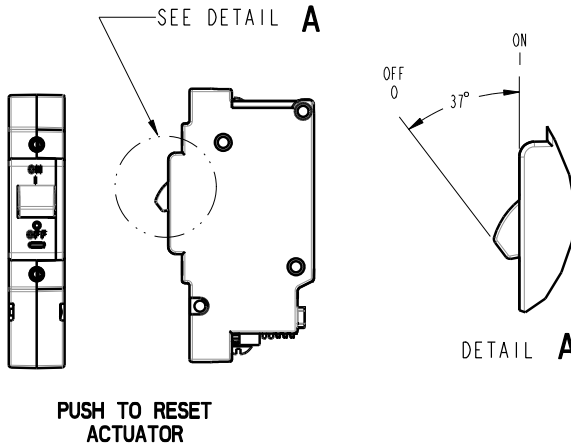
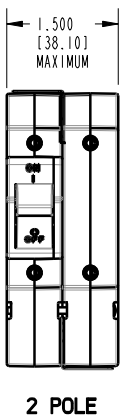
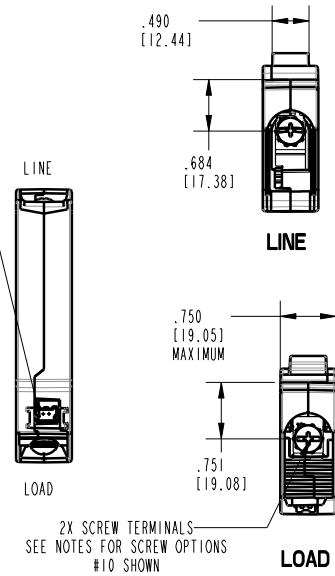
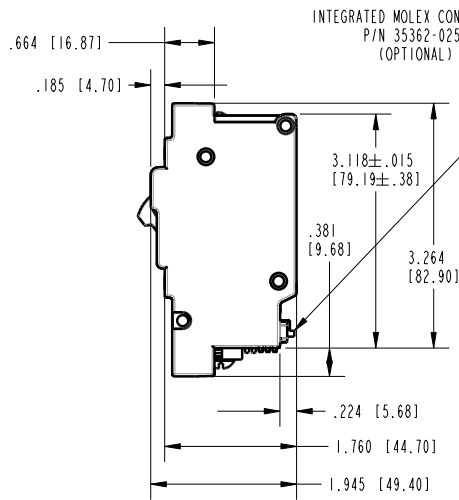
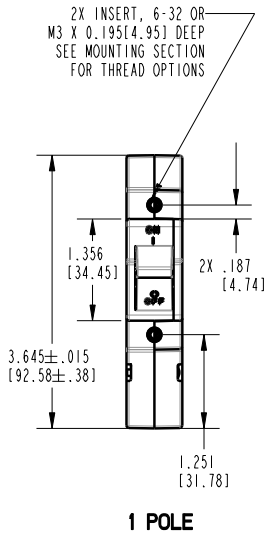

NOTES:
1. SCREWS HAVE COMBINATION HEAD
2. SCREW THREAD OPTIONS: #8-32, #10-32, M4X.7, M5X.8

Ultrashort - AC

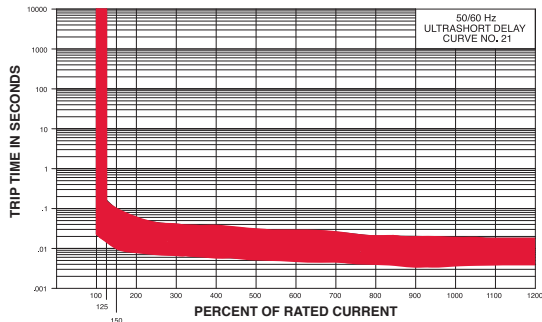

Short - High Inrush AC

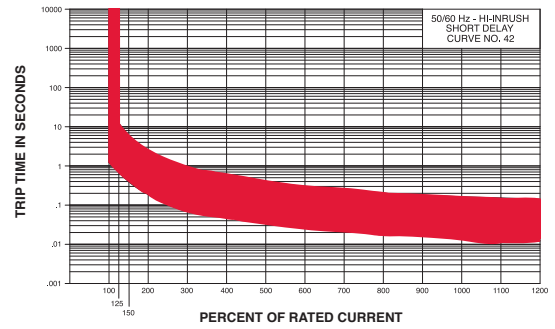

Short - AC

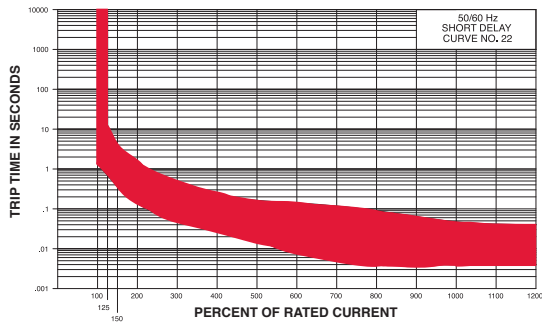

Medium - High Inrush AC

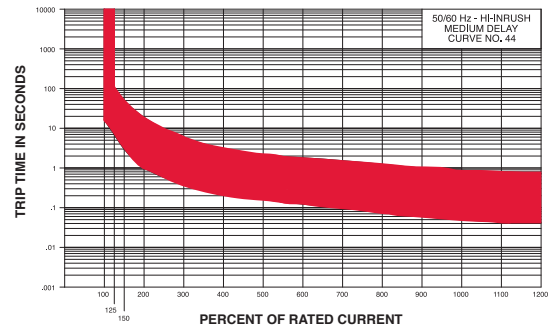

Medium - AC

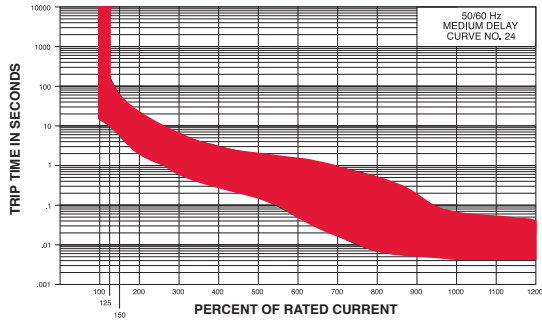

Long - High Inrush AC

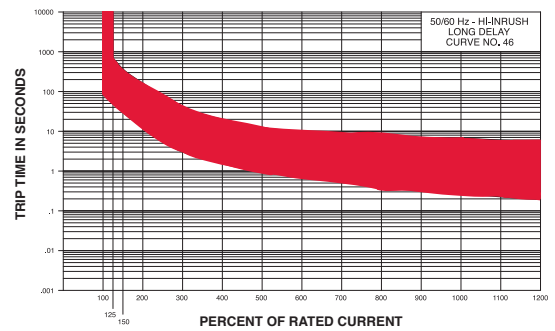

Long - AC

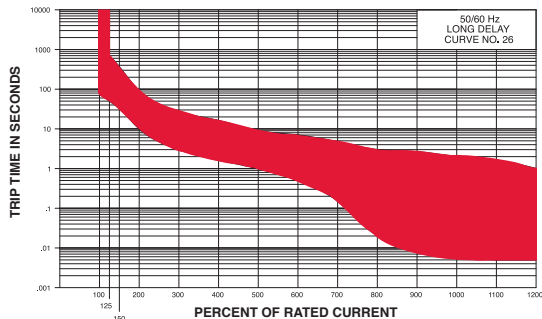

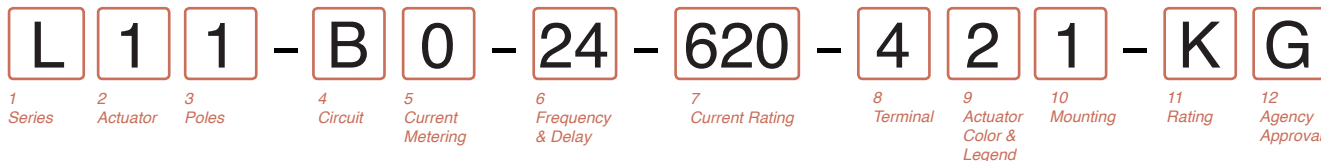

1 SERIES
L

2 ACTUATOR
 1 Single Color Low Profile Rocker, Vertical Legend
 2 Single Color Low Profile Rocker, Horizontal Legend
 3 Single Color Push to Reset Low Profile Rocker, Vertical Legend
 4 Single Color Push to Reset Low Profile Rocker, Horizontal Legend

3 POLES
 1 One
 2 Two
 3 Three¹

4 CIRCUIT
 B Series Trip (current)

5 CURRENT METERING⁴
 0 Without Current Transformer
 1 Integrated Current Transformer, 1 per unit²
 2 Integrated Current Transformer, 1 per pole

6 FREQUENCY & DELAY
 20 50/60Hz Instantaneous
 21 50/60Hz Ultra Short
 22 50/60Hz Short
 24 50/60Hz Medium
 26 50/60Hz Long
 42 50/60Hz Short, Hi-Inrush
 44 50/60Hz Medium, Hi-Inrush
 46 50/60Hz Long, Hi-Inrush

7 CURRENT RATING (AMPERES)

CODE	AMPERES				
410	1.000	460	6.000	613	13.000
512	1.250	465	6.500	614	14.000
415	1.500	470	7.000	615	15.000
517	1.750	475	7.500	616	16.000
420	2.000	480	8.000	617	17.000
522	2.250	485	8.500	618	18.000
425	2.500	490	9.000	620	20.000
527	2.750	495	9.500	622	22.000
430	3.000	610	10.000	624	24.000
435	3.500	710	10.500	625	25.000
440	4.000	611	11.000	630	30.000
445	4.500	711	11.500	632	32.000
450	5.000	612	12.000		
455	5.500	712	12.500		

8 TERMINAL
 2 Screw Terminal, 8-32 (Bus Type)
 4 Screw Terminal, 10-32 (Bus Type)
 E Screw Terminal, M4 (Bus Type)
 H Screw Terminal, M5 (Bus Type)

9 ACTUATOR COLOR & LEGEND

Actuator Color	I-O	ON-OFF	Dual	Legend Color
White	A	B	1	Black
Black	C	D	2	White
Red	F	G	3	White
Green	H	J	4	White
Blue	K	L	5	White
Yellow	M	N	6	Black
Gray	P	Q	7	Black
Orange	R	S	8	Black

10 MOUNTING INSERTS
 1 6-32 X .195 Threaded Inserts
 A 6-32 X .195 Threaded Inserts with Terminal Barrier
 2 ISO M3 X 5 mm Threaded Inserts
 B ISO M3 X 5 mm Threaded Inserts with Terminal Barrier

11 MAX. APPLICATION RATING
 C 120/240 VAC (2 or 3 Pole only)
 D 240 VAC
 K 120 VAC

12 AGENCY APPROVAL
 A Without approvals
 G UL 489 Listed
 3 UL 489 Listed, TUV Certified

Notes:
 1 3 Pole units available only when one of three poles is neutral
 2 On Multi Pole units one current transformer is supplied on the actuator pole
 3 Terminal barriers are required on multi poles breaker

Worldwide Headquarters

Carling Technologies, Inc.
60 Johnson Avenue • Plainville, CT 06062
Phone: (860) 793-9281 • Fax: (860) 793-9231
Email: sales@carlingtech.com • www.carlingtech.com

East Region Sales Office, CT • ersm@carlingtech.com
Midwest Region Sales Office, IL • mrrsm@carlingtech.com
West Region Sales Office, CA • wrsm@carlingtech.com

Asia-Pacific Headquarters

Carling Technologies, Asia-Pacific Ltd.,
Kowloon, Hong Kong
Int + 852-2737-2277 • Fax: Int + 852-2736-9332
Email: sales@carlingtech.com.hk

Shenzhen, China • shenzhen@carlingtech.com
Shanghai, China • shanghai@carlingtech.com
Pune, India • india@carlingtech.com
Kaohsiung, Taiwan • taiwan@carlingtech.com
Yokohama, Japan • japan@carlingtech.com

Europe / Middle East / Africa Headquarters

Carling Technologies LTD
4 Airport Business Park, Exeter Airport,
Clyst Honiton, Exeter, Devon, EX5 2UL, UK
Int + 44 1392-364422 • Fax: Int + 44 1392-364477
Email: ltd.sales@carlingtech.com

GmbH, Germany • gmbh@carlingtech.com
SAS, France • sas@carlingtech.com

REV_CB_L_01_2014



Carling Technologies™

Innovative Designs. Powerful Solutions.