



REVISION HISTORY

<u>Revision</u>	<u>Description</u>	<u>Issue Date</u>
Rev. 1.0	Initial Issue	Sep.6.2007
Rev. 1.1	Added -45 ns Spec. Added –SLE/SLI Spec.	Nov.9.2007



FEATURES

- Fast access time : 35/45/55/70ns
- Low power consumption:
Operating current : 50/45/40/30mA (TYP.)
Standby current : 5µA (TYP.)
- Single 4.5V ~ 5.5V power supply
- All inputs and outputs TTL compatible
- Fully static operation
- Tri-state output
- Data byte control : LB# (DQ0 ~ DQ7)
UB# (DQ8 ~ DQ15)
- Data retention voltage : 2.0V (MIN.)
- **Lead free and green package available**
- Package : 44-pin 400 mil TSOP-II
48-ball 6mm x 8mm TFBGA

PRODUCT FAMILY

GENERAL DESCRIPTION

The LY6225616 is a 4,194,304-bit low power CMOS static random access memory organized as 262,144 words by 16 bits. It is fabricated using very high performance, high reliability CMOS technology. Its standby current is stable within the range of operating temperature.

The LY6225616 is well designed for low power application, and particularly well suited for battery back-up nonvolatile memory application.

The LY6225616 operates from a single power supply of 4.5V ~ 5.5V and all inputs and outputs are fully TTL compatible

Product Family	Operating Temperature	Vcc Range	Speed	Power Dissipation	
				Standby(I _{SB1} ,TYP.)	Operating(I _{CC} ,TYP.)
LY6225616(LL)	0 ~ 70°C	4.5 ~ 5.5V	35/45/55/70ns	5µA	50/45/40/30mA
LY6225616(LLE)	-20 ~ 80°C	4.5 ~ 5.5V	35/45/55/70ns	5µA	50/45/40/30mA
LY6225616(LLI)	-40 ~ 85°C	4.5 ~ 5.5V	35/45/55/70ns	5µA	50/45/40/30mA
LY6225616(SL)	0 ~ 70°C	4.5 ~ 5.5V	35/45/55/70ns	5µA	50/45/40/30mA
LY6225616(SLE)	-20 ~ 80°C	4.5 ~ 5.5V	35/45/55/70ns	5µA	50/45/40/30mA
LY6225616(SLI)	-40 ~ 85°C	4.5 ~ 5.5V	35/45/55/70ns	5µA	50/45/40/30mA

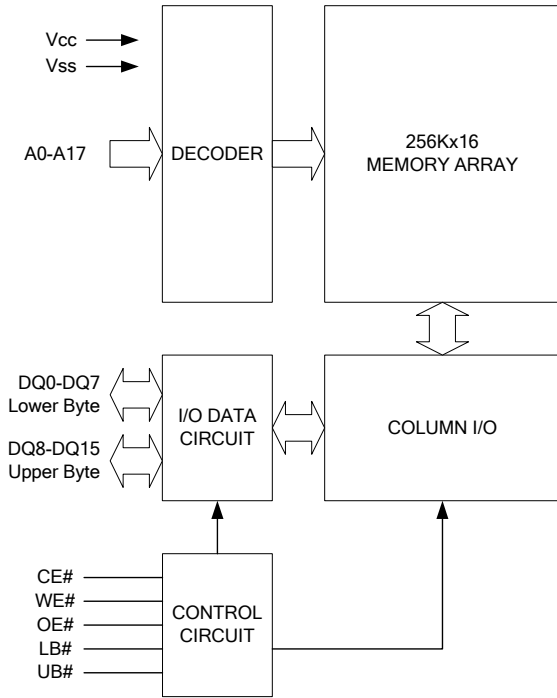
FUNCTIONAL BLOCK DIAGRAM

PIN DESCRIPTION

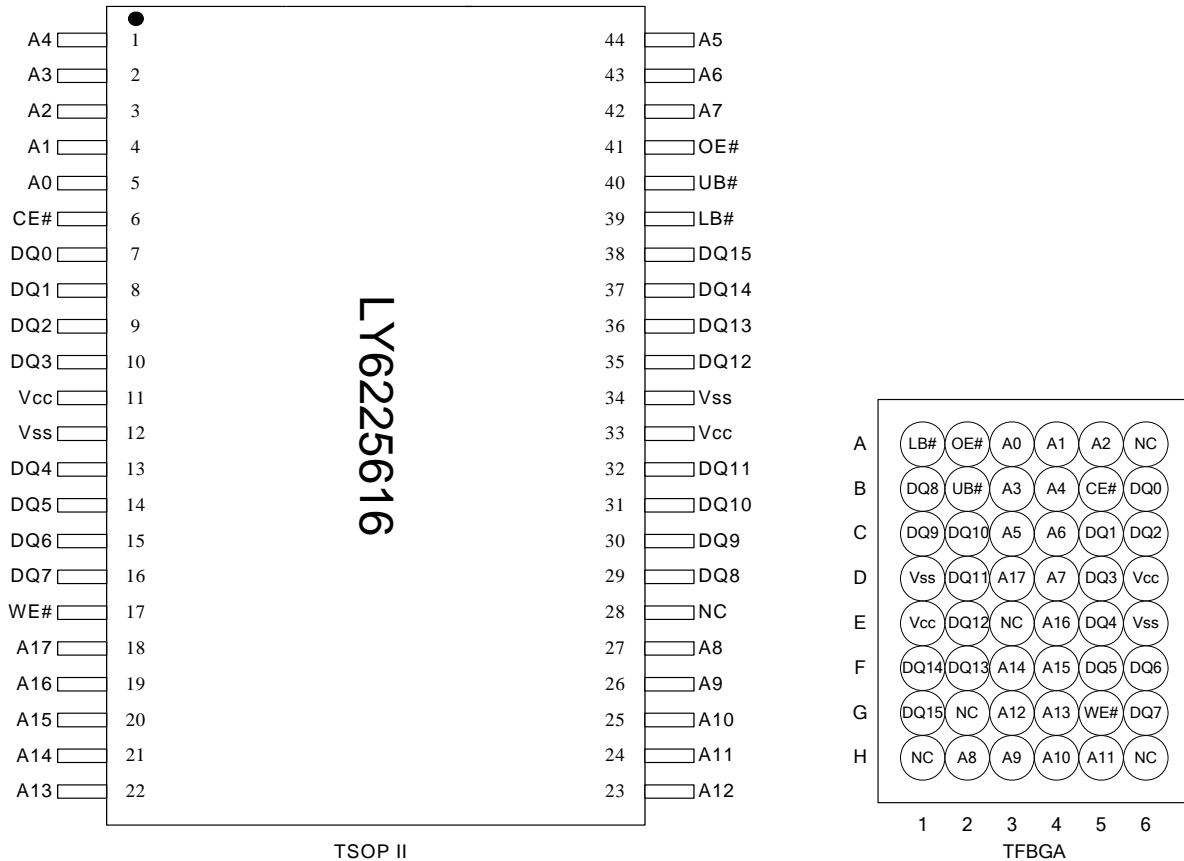
SYMBOL	DESCRIPTION
A0 - A17	Address Inputs
DQ0 – DQ15	Data Inputs/Outputs
CE#	Chip Enable Input
WE#	Write Enable Input
OE#	Output Enable Input
LB#	Lower Byte Control
UB#	Upper Byte Control
Vcc	Power Supply
Vss	Ground

PIN CONFIGURATION

ABSOLUTE MAXIMUM RATINGS*

PARAMETER	SYMBOL	RATING	UNIT
Voltage on Vcc relative to Vss	V_{T1}	-0.5 to 6.5	V
Voltage on any other pin relative to Vss	V_{T2}	-0.5 to Vcc+0.5	V
Operating Temperature	T_A	0 to 70(C grade)	°C
		-20 to 80(E grade)	
		-40 to 85(I grade)	
Storage Temperature	T_{STG}	-65 to 150	°C
Power Dissipation	P_D	1	W
DC Output Current	I_{OUT}	50	mA
Soldering Temperature (under 10 sec)	T_{SOLDER}	260	°C

*Stresses greater than those listed under "Absolute Maximum Ratings" may cause permanent damage to the device. This is a stress rating only and functional operation of the device or any other conditions above those indicated in the operational sections of this specification is not implied. Exposure to the absolute maximum rating conditions for extended period may affect device reliability.



TRUTH TABLE

MODE	CE#	OE#	WE#	LB#	UB#	I/O OPERATION		SUPPLY CURRENT
						DQ0-DQ7	DQ8-DQ15	
Standby	H	X	X	X	X	High - Z	High - Z	I _{SB1}
	X	X	X	H	H	High - Z	High - Z	
Output Disable	L	H	H	L	X	High - Z	High - Z	I _{CC} , I _{CC1}
	L	H	H	X	L	High - Z	High - Z	
Read	L	L	H	L	H	D _{OUT}	High - Z	I _{CC} , I _{CC1}
	L	L	H	H	L	High - Z	D _{OUT}	
	L	L	H	L	L	D _{OUT}	D _{OUT}	
Write	L	X	L	L	H	D _{IN}	High - Z	I _{CC} , I _{CC1}
	L	X	L	H	L	High - Z	D _{IN}	
	L	X	L	L	L	D _{IN}	D _{IN}	

Note: H = V_{IH}, L = V_{IL}, X = Don't care.

DC ELECTRICAL CHARACTERISTICS

PARAMETER	SYMBOL	TEST CONDITION	MIN.	TYP. ⁴	MAX.	UNIT
Supply Voltage	V _{CC}		4.5	5.0	5.5	V
Input High Voltage	V _{IH} ¹		2.4	-	V _{CC} +0.3	V
Input Low Voltage	V _{IL} ²		-0.2	-	0.6	V
Input Leakage Current	I _{LI}	V _{CC} ≥ V _{IN} ≥ V _{SS}	-1	-	1	μA
Output Leakage Current	I _{LO}	V _{CC} ≥ V _{OUT} ≥ V _{SS} , Output Disabled	-1	-	1	μA
Output High Voltage	V _{OH}	I _{OH} = -1mA	2.4	-	-	V
Output Low Voltage	V _{OL}	I _{OL} = 2mA	-	-	0.4	V
Average Operating Power supply Current	I _{CC}	Cycle time = Min. CE# = V _{IL} , I _{I/O} = 0mA Other pins at V _{IL} or V _{IH}	-35	50	80	mA
			-45	45	70	mA
			-55	40	60	mA
			-70	30	50	mA
	I _{CC1}	Cycle time = 1μs CE# = 0.2V, I _{I/O} = 0mA Other pins at 0.2V or V _{CC} - 0.2V	-	4	10	mA
Standby Power Supply Current	I _{SB1}	CE# ≥ V _{CC} - 0.2V Others at 0.2V or V _{CC} - 0.2V	-SL	5	25	μA
			-SLE/-SLI	5	35	μA
			-LL	5	50	μA

Notes:

- V_{IH}(max) = V_{CC} + 3.0V for pulse width less than 10ns.
- V_{IL}(min) = V_{SS} - 3.0V for pulse width less than 10ns.
- Over/Undershoot specifications are characterized, not 100% tested.
- Typical values are included for reference only and are not guaranteed or tested.
Typical values are measured at V_{CC} = V_{CC}(TYP.) and T_A = 25°C

CAPACITANCE (T_A = 25°C, f = 1.0MHz)

PARAMETER	SYMBOL	MIN.	MAX	UNIT
Input Capacitance	C _{IN}	-	6	pF
Input/Output Capacitance	C _{I/O}	-	8	pF

Note : These parameters are guaranteed by device characterization, but not production tested.



AC TEST CONDITIONS

Input Pulse Levels	0.2V to $V_{CC} - 0.2V$
Input Rise and Fall Times	3ns
Input and Output Timing Reference Levels	1.5V
Output Load	$C_L = 30pF + 1TTL, I_{OH}/I_{OL} = -2mA/4mA$

AC ELECTRICAL CHARACTERISTICS

(1) READ CYCLE

PARAMETER	SYM.	LY6225616-35		LY6225616-45		LY6225616-55		LY6225616-70		UNIT
		MIN.	MAX.	MIN.	MAX.	MIN.	MAX.	MIN.	MAX.	
Read Cycle Time	t _{RC}	35	-	45	-	55	-	70	-	ns
Address Access Time	t _{AA}	-	35	-	45	-	55	-	70	ns
Chip Enable Access Time	t _{ACE}	-	35	-	45	-	55	-	70	ns
Output Enable Access Time	t _{OE}	-	25	-	25	-	30	-	35	ns
Chip Enable to Output in Low-Z	t _{CLZ*}	10	-	10	-	10	-	10	-	ns
Output Enable to Output in Low-Z	t _{OLZ*}	5	-	5	-	5	-	5	-	ns
Chip Disable to Output in High-Z	t _{CHZ*}	-	15	-	15	-	20	-	25	ns
Output Disable to Output in High-Z	t _{OHZ*}	-	15	-	15	-	20	-	25	ns
Output Hold from Address Change	t _{OH}	10	-	10	-	10	-	10	-	ns
LB#, UB# Access Time	t _{BA}	-	35	-	45	-	55	-	70	ns
LB#, UB# to High-Z Output	t _{BHZ*}	-	20	-	20	-	25	-	30	ns
LB#, UB# to Low-Z Output	t _{BLZ*}	10	-	10	-	10	-	10	-	ns

(2) WRITE CYCLE

PARAMETER	SYM.	LY6225616-35		LY6225616-45		LY6225616-55		LY6225616-70		UNIT
		MIN.	MAX.	MIN.	MAX.	MIN.	MAX.	MIN.	MAX.	
Write Cycle Time	t _{WC}	35	-	45	-	55	-	70	-	ns
Address Valid to End of Write	t _{AW}	30	-	40	-	50	-	60	-	ns
Chip Enable to End of Write	t _{CW}	30	-	40	-	50	-	60	-	ns
Address Set-up Time	t _{AS}	0	-	0	-	0	-	0	-	ns
Write Pulse Width	t _{WP}	25	-	35	-	45	-	55	-	ns
Write Recovery Time	t _{WR}	0	-	0	-	0	-	0	-	ns
Data to Write Time Overlap	t _{DW}	20	-	20	-	25	-	30	-	ns
Data Hold from End of Write Time	t _{DH}	0	-	0	-	0	-	0	-	ns
Output Active from End of Write	t _{OW*}	5	-	5	-	5	-	5	-	ns
Write to Output in High-Z	t _{WHZ*}	-	15	-	15	-	20	-	25	ns
LB#, UB# Valid to End of Write	t _{BW}	30	-	35	-	50	-	60	-	ns

*These parameters are guaranteed by device characterization, but not production tested.



TIMING WAVEFORMS

READ CYCLE 1 (Address Controlled) (1,2)

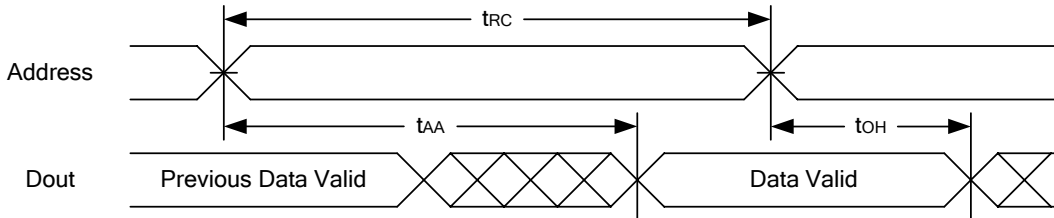

READ CYCLE 2 (CE# and OE# Controlled) (1,3,4,5)

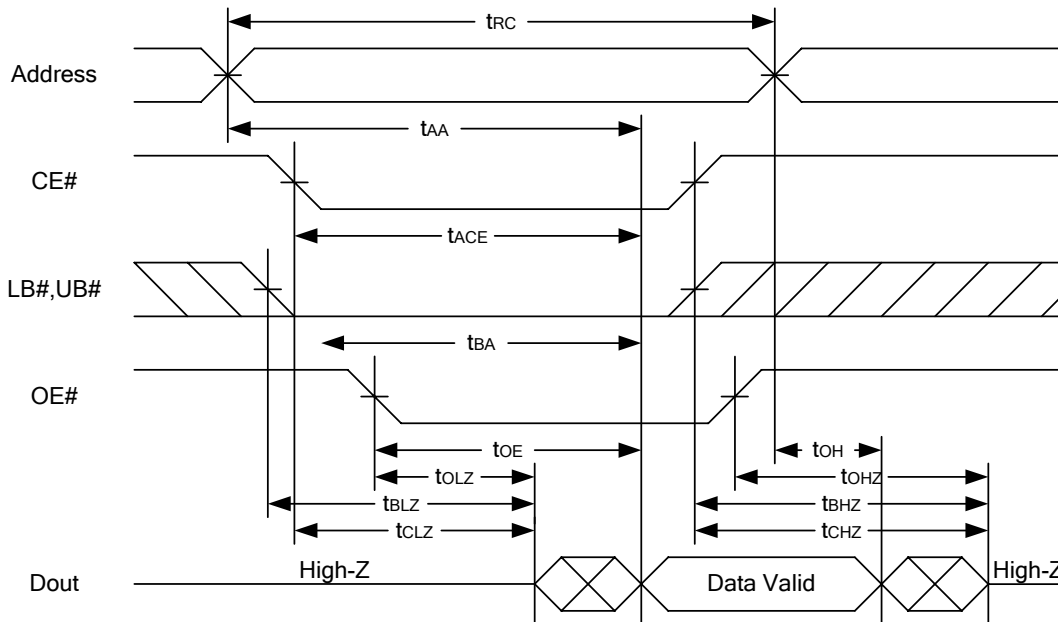

Notes :

1. WE# is high for read cycle.
2. Device is continuously selected OE# = low, CE# = low, LB# or UB# = low.
3. Address must be valid prior to or coincident with CE# = low, LB# or UB# = low transition; otherwise t_{AA} is the limiting parameter.
4. t_{CLZ} , t_{BLZ} , t_{OLZ} , t_{CHZ} , t_{BHZ} and t_{OHZ} are specified with $C_L = 5pF$. Transition is measured $\pm 500mV$ from steady state.
5. At any given temperature and voltage condition, t_{CHZ} is less than t_{CLZ} , t_{BHZ} is less than t_{BLZ} , t_{OHZ} is less than t_{OLZ} .

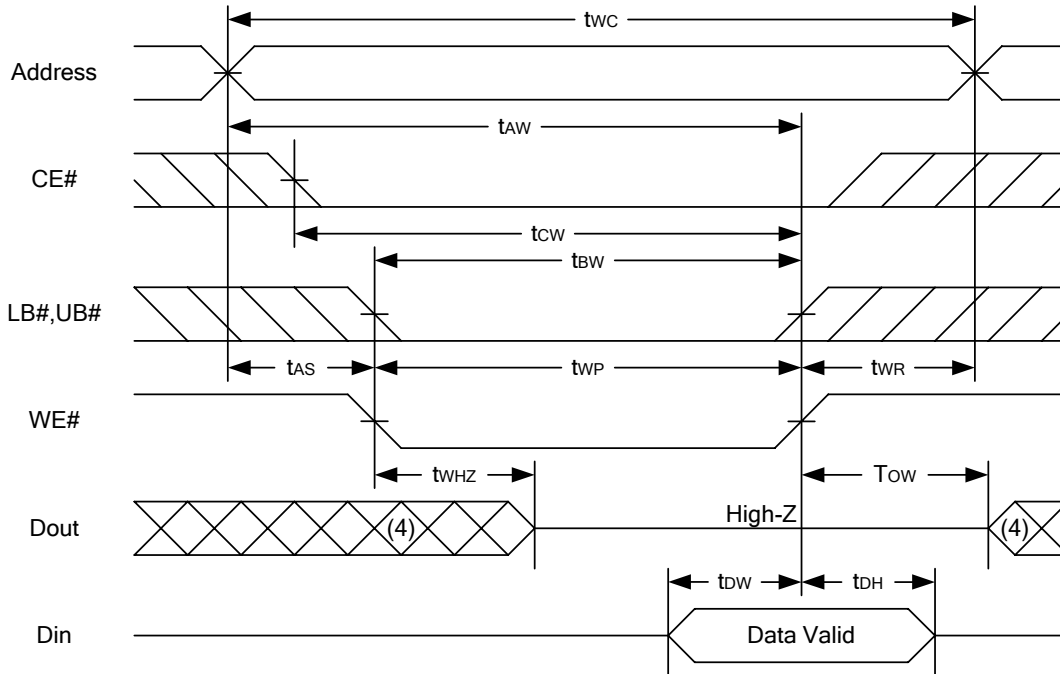
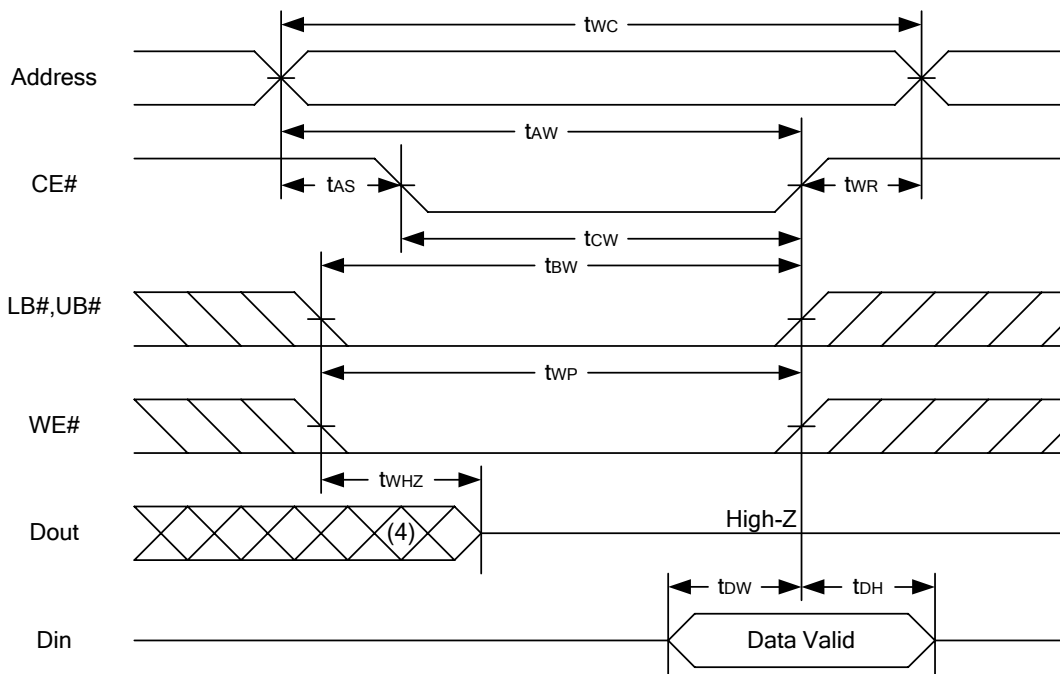
WRITE CYCLE 1 (WE# Controlled) (1,2,3,5,6)

WRITE CYCLE 2 (CE# Controlled) (1,2,5,6)

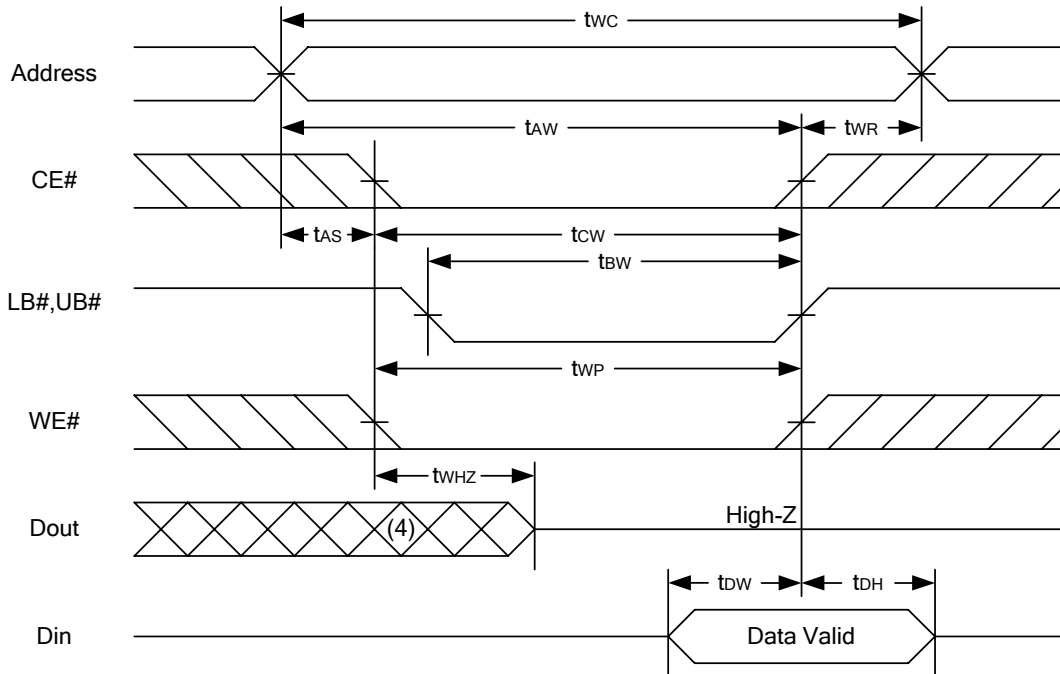

WRITE CYCLE 3 (LB#,UB# Controlled) (1,2,5,6)



Notes :

1. WE#, CE#, LB#, UB# must be high during all address transitions.
2. A write occurs during the overlap of a low CE#, low WE#, LB# or UB# = low.
3. During a WE# controlled write cycle with OE# low, tWP must be greater than tWHZ + tDW to allow the drivers to turn off and data to be placed on the bus.
4. During this period, I/O pins are in the output state, and input signals must not be applied.
5. If the CE#, LB#, UB# low transition occurs simultaneously with or after WE# low transition, the outputs remain in a high impedance state.
6. tDW and tWHZ are specified with CL = 5pF. Transition is measured ±500mV from steady state.

DATA RETENTION CHARACTERISTICS

PARAMETER	SYMBOL	TEST CONDITION	MIN.	TYP.	MAX.	UNIT
Vcc for Data Retention	V_{DR}	$CE\# \geq V_{CC} - 0.2V$	2.0	-	5.5	V
Data Retention Current	I_{DR}	$V_{CC} = 2.0V$	-	2	20	μA
		$CE\# \geq V_{CC} - 0.2V$	-	2	25	μA
		Other pins at 0.2V or $V_{CC} - 0.2V$	-	2	20	μA
Chip Disable to Data Retention Time	t_{CDR}	See Data Retention Waveforms (below)	0	-	-	ns
Recovery Time	t_R		t_{RC*}	-	-	ns

 t_{RC*} = Read Cycle Time

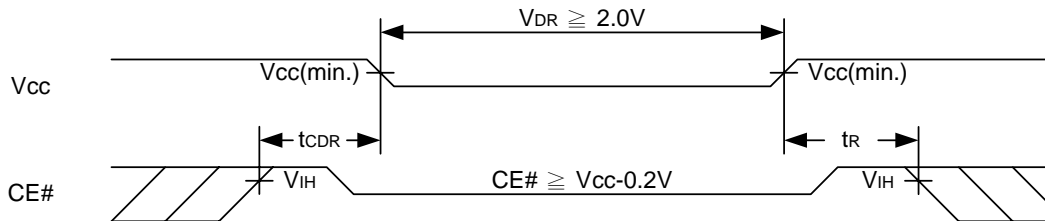
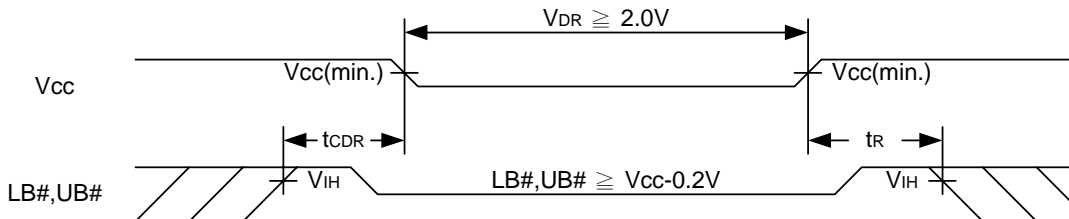
DATA RETENTION WAVEFORM
Low Vcc Data Retention Waveform (1) (CE# controlled)

Low Vcc Data Retention Waveform (2) (LB#, UB# controlled)

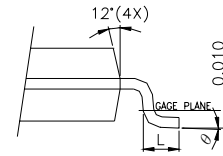
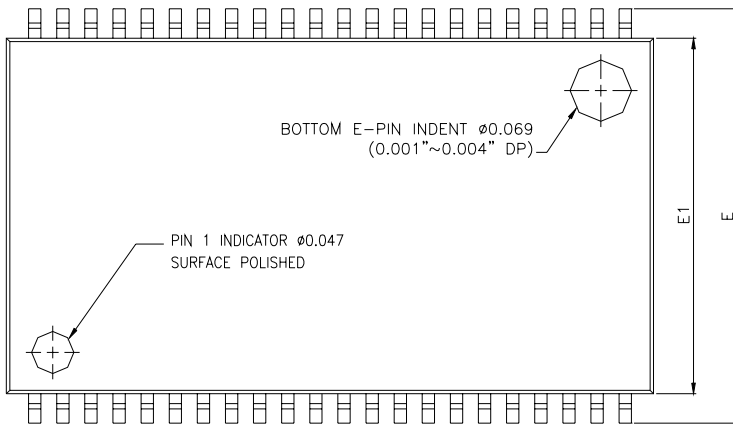

PACKAGE OUTLINE DIMENSION

44-pin 400mil TSOP-II Package Outline Dimension



DETAIL B

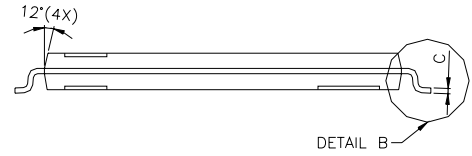
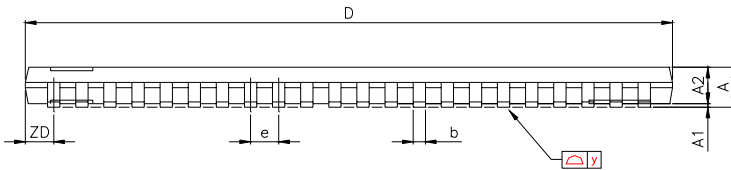

DETAIL B

SYMBOLS	DIMENSIONS IN MILLMETERS			DIMENSIONS IN MILS		
	MIN.	NOM.	MAX.	MIN.	NOM.	MAX.
A	-	-	1.20	-	-	47.2
A1	0.05	0.10	0.15	2.0	3.9	5.9
A2	0.95	1.00	1.05	37.4	39.4	41.3
b	0.30	-	0.45	11.8	-	17.7
c	0.12	-	0.21	4.7	-	8.3
D	18.212	18.415	18.618	717	725	733
E	11.506	11.760	12.014	453	463	473
E1	9.957	10.160	10.363	392	400	408
e	-	0.800	-	-	31.5	-
L	0.40	0.50	0.60	15.7	19.7	23.6
ZD	-	0.805	-	-	31.7	-
y	-	-	0.076	-	-	3
θ	0°	3°	6°	0°	3°	6°

48-ball 6mm x 8mm TFBGA Package Outline Dimension

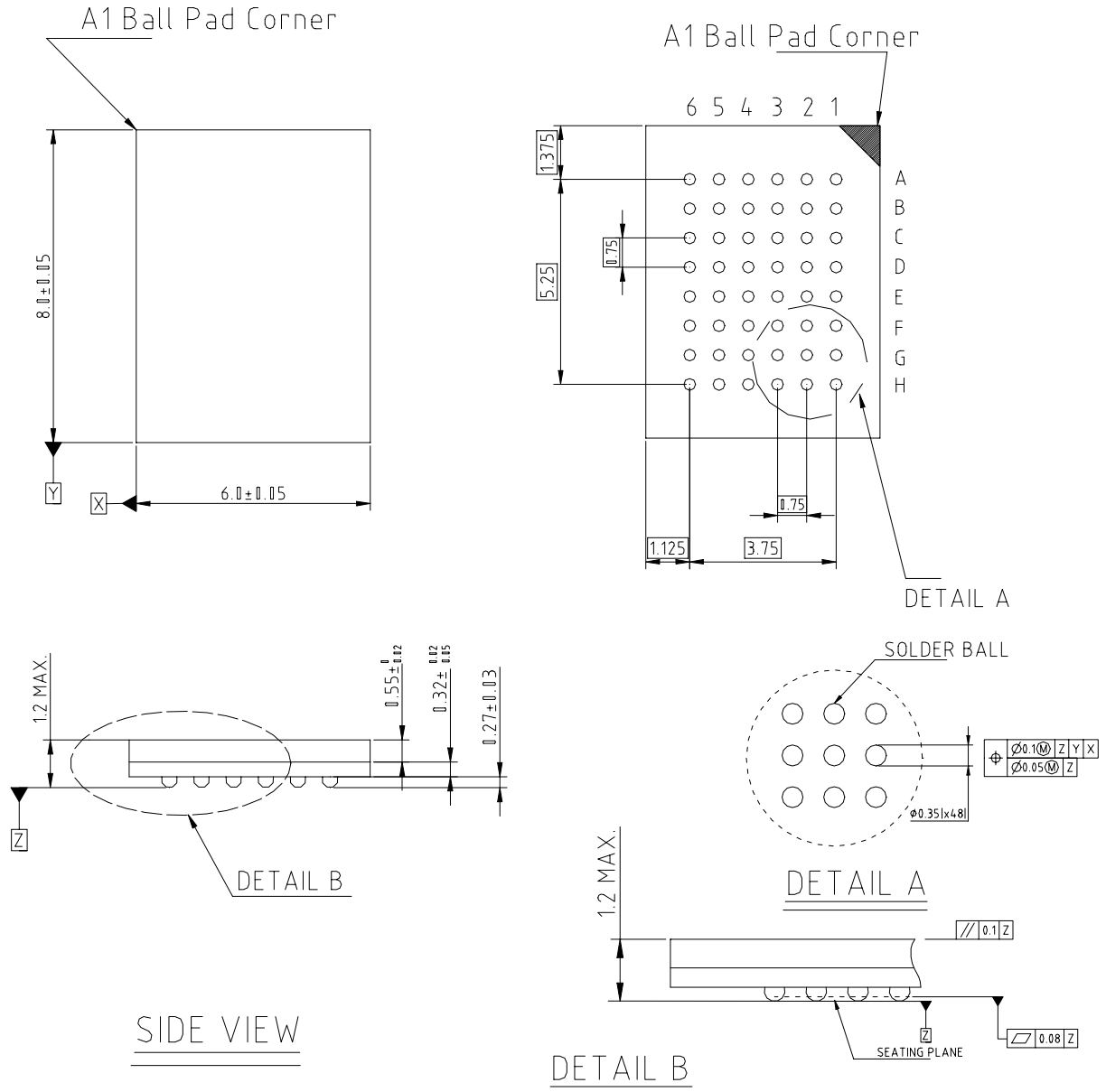



ORDERING INFORMATION

LY6225616 V W - XX YY Z

Z : Temperature Range
Blank : (Commercial) 0°C ~ 70°C
E : (Extended) -20°C ~ +80°C
I : (Industrial) -40°C ~ +85°C

YY : Power Type
LL : Ultra Low Power
SL : Special Ultra Low Power

XX : Access Time(Speed)

W : Lead Information
N : Normal
L : Lead Free

V : Package Type
M : 44-pin 400 mil TSOP-II
G : 48-ball 6 mm x 8 mm TFBGA



Lyontek Inc.

LY6225616

Rev. 1.1

256K X 16 BIT LOW POWER CMOS SRAM

THIS PAGE IS LEFT BLANK INTENTIONALLY.