



A29DL323 Series

32M-Bit CMOS Low Voltage Dual Operation Flash Memory

Preliminary 4M-Byte by 8-Bit (Byte Mode) / 2M-Word by 16-Bit (Word Mode)

Features

- Two bank organization enabling simultaneous execution of erase / program and read
- Bank organization: 2 banks (8 Mbits + 24 Mbits)
- Memory organization:
 - 4,194,304 words x 8 bits (BYTE mode)
 - 2,097,152 words x 16 bits (WORD mode)
- Sector organization:
 - 71 sectors (8 Kbytes / 4 Kwords x 8 sectors, 64 Kbytes / 32 Kwords x 63 sectors)
- 2 types of sector organization
 - T type: Boot sector allocated to the highest address (sector)
 - B type: Boot sector allocated to the lowest address (sector)
- 3-state output
- Automatic program
 - Program suspend / resume
- Unlock bypass program
- Automatic erase
 - Chip erase
 - Sector erase (sectors can be combined freely)
- Erase suspend / resume
- Program / Erase completion detection
 - Detection through data polling and toggle bits
 - Detection through RY/B \bar{Y} pin
- Sector group protection
 - Any sector group can be protected
 - Any protected sector group can be temporary unprotected
- Sectors can be used for boot application
- Hardware reset and standby using $\overline{\text{RESET}}$ pin
- Automatic sleep mode
- Boot block sector protect by $\overline{\text{WP}}$ (ACC) pin
- Conforms to common flash memory interface (CFI)
- Extra One Time Protect Sector provided

Part No.	Access time (Max.)	Operating supply voltage	Power supply current (Active mode) (Max.)		Standby current (Max.)
A29DL323	90ns	2.7V~3.6V	16mA	30mA	5 A

- Operating ambient temperature: -40 to 85°C
- Program / erase time
 - Program: 9.0 μ s / byte (TYP.)
 - 11.0 μ s / word (TYP.)
 - Sector erase: 0.7 s (TYP.)
- Number of program / erase: 1,000,000 times (MIN.)
- Package options
 - 48-pin TSOP (I) or 63-ball TFBGA

General Description

The A29DL323 is a flash memory organized of 33,554,432 bits and 71 sectors. Sectors of this memory can be erased at a low voltage (2.7 to 3.6 V) supplied from a single power source, or the contents of the entire chip can be erased. Two modes of memory organization, BYTE mode (4,194,304 words x 8 bits) and WORD mode (2,097,152 words x 16 bits), are selectable so that the memory can be programmed in byte or word units.

The A29DL323 can be read while its contents are being erased or programmed. The memory cell is divided into two banks. While sectors in one bank are being erased or programmed, data can be read from the other bank thanks to the simultaneous execution architecture. The banks are 8 Mbits and 24 Mbits.

This flash memory comes in two types. The T type has a boot sector located at the highest address (sector) and the B type has a boot sector at the lowest address (sector).

Because the A29DL323 enables the boot sector to be erased, it is ideal for storing a boot program. In addition, program code that controls the flash memory can be also stored, and the program code can be programmed or erased without the need to load it into RAM. Eight small sectors for storing parameters are provided, each of which can be erased in 8 Kbytes units.

Once a program or erase command sequence has been executed, an automatic program or automatic erase function internally executes program or erase and verification automatically.

Because the A29DL323 can be electrically erased or programmed by writing an instruction, data can be reprogrammed on-board after the flash memory has been installed in a system, making it suitable for a wide range of applications.

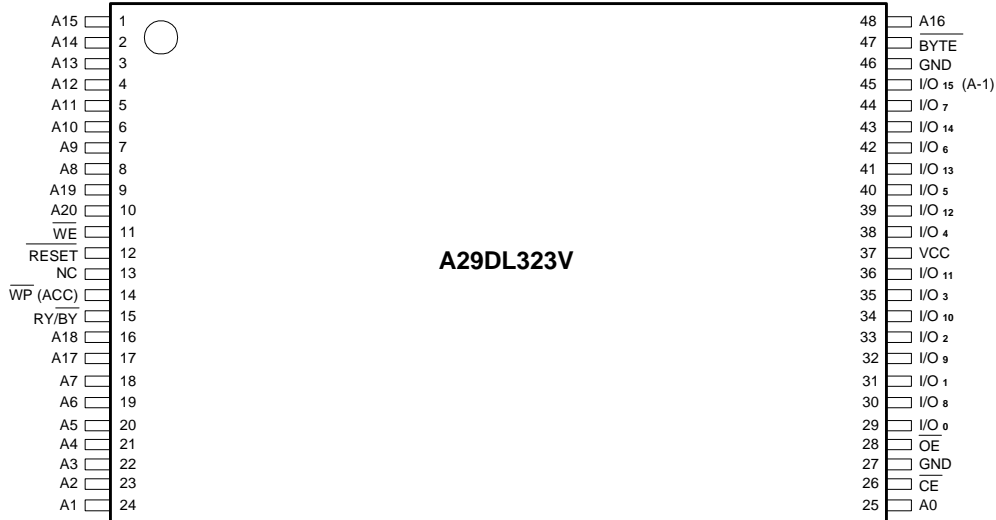
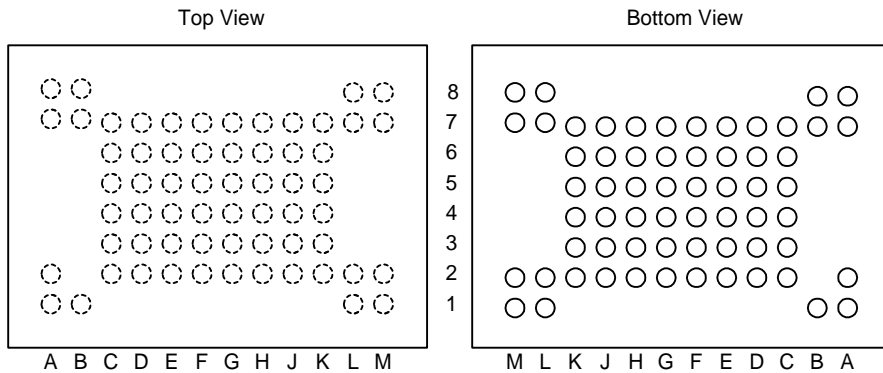
Pin Configurations
■ TSOP (I)

■ TFBGA

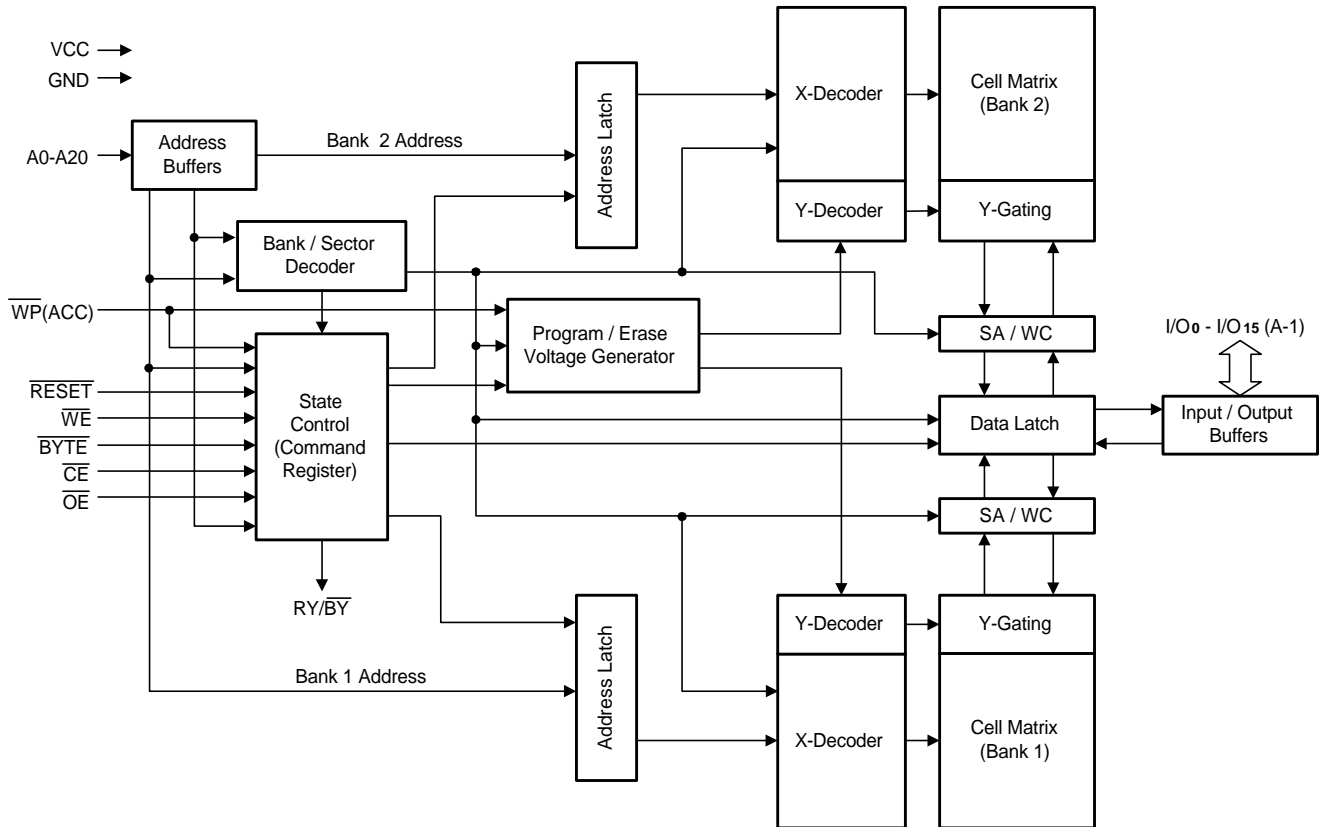
		Top View											
		A	B	C	D	E	F	G	H	J	K	L	M
1		NC	NC									NC	NC
2		NC	NC	A13	A12	A14	A15	A16	BYTE	I/O15(A-1)	GND	NC	NC
3				A9	A8	A10	A11	I/O7	I/O14	I/O13	I/O6		
4				WE	RESET	NC	A19	I/O5	I/O12	VCC	I/O4		
5				RY/BY	WP (ACC)	A18	A20	I/O2	I/O10	I/O11	I/O3		
6				A7	A17	A6	A5	I/O0	I/O8	I/O9	I/O1		
7		NC		A3	A4	A2	A1	A0	CE	OE	GND	NC	NC
8		NC	NC									NC	NC

Block Diagram

Pin Descriptions

Pin No.	Description	
A0 – A20	Address Inputs	
I/O ₀ - I/O ₁₄	Data Inputs/Outputs	
I/O ₁₅ (A-1)	I/O ₁₅	Data Input/Output, Word Mode
	A-1	LSB Address Input, Byte Mode
\overline{CE}	Chip Enable	
\overline{WE}	Write Enable	
\overline{OE}	Output Enable	
\overline{RESET}	Hardware Reset Input	
\overline{BYTE}	Mode Select	
RY/ \overline{BY}	Ready/ \overline{BUSY} - Output	
\overline{WP} (ACC)	Write Protect (Accelerated) Input	
GND	Ground	
VCC	Power Supply	
NC ^{Note}	No Connection	

Note: Some signals can be applied because this pin is not connected to the inside of the chip.

Input / Output Pin Function

Pin Name	Input / Output	Function
A0 to A20	Input	Address input pins. A0 to A20 are used differently in the BYTE mode and the WORD mode. BYTE MODE A0 to A20 are used as the upper 21 bits of total 22 bits of address input pin. (The least significant bit (A-1) is combined to I/O ₁₅ .) WORD MODE A0 to A20 are used as 21 bits address input pin.
I/O ₀ to I/O ₁₄	Input / Output	Data input / output pins. I/O ₀ to I/O ₁₄ are used differently in the BYTE mode and the WORD mode. BYTE MODE I/O ₀ to I/O ₇ are used as the 8 bits data input / output pins. I/O ₈ to I/O ₁₄ are Hi-Z. WORD MODE I/O ₀ to I/O ₁₄ are used as the lower 15 bits of total 16 bits of data input / output pins. (The most significant bit (I/O ₁₅) is combined to A-1.)
I/O ₁₅ , A-1	Input / Output	I/O ₁₅ , A1 are used differently in the BYTE mode and the WORD mode. BYTE MODE The least significant address input pin (A-1) WORD MODE The most significant data input / output pin (I/O ₁₅)
$\overline{\text{CE}}$	Input	This pin inputs the signal that activates the chip. When high level, the chip enters the standby mode.
$\overline{\text{OE}}$	Input	This pin inputs the read operation control signal. When high level, output is Hi-Z.
$\overline{\text{WE}}$	Input	This pin inputs the write operation control signal. When low level, command input is accepted.
BYTE	Input	The pin for switching BYTE mode and WORD mode. High level : WORD MODE (2M words x 16 bits) Low level : BYTE MODE (4M words x 8 bits)
$\overline{\text{RESET}}$	Input	This pin inputs hardware reset. When low level, hardware reset is performed. If 11.5 to 12.5 V is applied to $\overline{\text{RESET}}$, the chip enters the temporary sector group unprotect mode.
RY/ $\overline{\text{BY}}$	Output	This pin indicates whether automatic program / erase is currently being executed. It uses open drain connection. Low level indicates the busy state during which the device is performing automatic program erase. High level indicates the device is in the ready state and will accept the next operation. In this case, the device is either in the erase suspend mode or the standby mode.
$\overline{\text{WP}}$ (ACC)	Input	This pin selects the boot block sector protect mode or accelerated mode. Low level: The boot block (2 sectors) is protected. High level: The boot block is unprotected. VACC level: Accelerated mode is selected.
VCC	-	Supply Voltage
GND	-	Ground
NC	-	No Connection

Absolute Maximum Ratings*

Storage Temperature (T _{stg})	-55°C to +125°C
Operating Ambient Temperature (T _a)	-40°C to +85°C
Input / Output Voltage with Respect to GND	
\overline{WP} (ACC), \overline{RESET}	-0.5V ^{Note1} to 13.0V
All Pins except \overline{WP} (ACC), \overline{RESET}	-0.5V ^{Note1} to VCC + 0.4 (4.0V max.) ^{Note2}
Supply Voltage with Respect to GND (VCC)	-0.5V to 4.0V

Notes:

- 2.0V (Min.) (Pulse width ≤ 20ns)
- VCC + 0.5V (Max.) (Pulse width ≤ 20ns)

Bus Operations

The following table shows the operation modes of the dual operation flash memory. Before turning on power, input

***Comments**

Stresses above those listed under "Absolute Maximum Ratings" may cause permanent damage to this device. These are stress ratings only. Functional operation of this device at these or any other conditions above those indicated in the operational sections of these specification is not implied or intended. Exposure to the absolute maximum rating conditions for extended periods may affect device reliability.

Recommended Operating Conditions

Operating Ambient Temperature (T _a)	-40°C to +85°C
Supply Voltage (VCC)	+2.7V to +3.6V

GND ± 0.2 V to the \overline{RESET} until VCC ≥ VCC (min.).

Table 1. A29DL323 Bus Operations

Operation		\overline{CE}	\overline{OE}	\overline{WE}	I/O ₁₅ , A-1	A6	A1	A0	I/O ₀ to I/O ₇	I/O ₈ to I/O ₁₅	\overline{RESET}	\overline{WP} (ACC)
Read (Note)	BYTE mode	L	L	H	A-1	Address input			Data output	Hi-Z	H	X
	WORD mode	L	L	H	X	Address input			Data output		H	X
Write	BYTE mode	L	H	L	A-1	Address input			Data input	Hi-Z	H	Note3
	WORD mode	L	H	L	X	Address input			Data input		H	Note3
Standby		H	X	X	X	X	X	X	Hi-Z	Hi-Z	H	X
Hardware reset / Standby		X	X	X	X	X	X	X	Hi-Z	Hi-Z	L	X
Output Disable		L	H	H	X	X	X	X	Hi-Z	Hi-Z	H	X
Temporary Sector Group Unprotect		X	X	X	X	X	X	X	Hi-Z or Data input / output		V _{ID}	Note3
Automatic Sleep Mode	BYTE mode	L	L	H	A-1	Address input			Data output	Hi-Z	H	X
	WORD mode	L	L	H	X	Address input			Data output		H	X
Boot Block Sector Protect		X	X	X	X	X	X	X	Hi-Z or Data input / output		X	L
Accelerated Mode	BYTE mode	L	H	L	A-1	Address input			Data input	Hi-Z	H	V _{ACC}
	WORD mode	L	H	L	X	Address input			Data input		H	V _{ACC}

Note: When $\overline{OE} = V_{IL}$, V_{IL} can be applied to \overline{WE} . When $\overline{OE} = V_{IH}$, a write operation is started.

Remarks: 1. H : V_{IH}, L : V_{IL}, : V_{IH} or V_{IL}, V_{ID} : 11.5 V to 12.5 V, V_{ACC} : 8.5 V to 9.5 V

2. If an address is held longer than the minimum read cycle time (t_{RC}), the automatic sleep mode is set.

3. If \overline{WP} (ACC)=V_{IL}, sector 0,1,140, and 141 remain protected. If \overline{WP} (ACC)=V_{IH}, protection on sectors 0,1,140, and 141 depends on whether they were last protected or unprotected using the method described in "Sector/Block Protection and Unprotection". If \overline{WP} (ACC)=V_{HH}, all sectors will be unprotected.

Read Operation

The read operation is controlled by the \overline{OE} and $/OE$. The $/CE$ is used to select a device, and the \overline{OE} controls data output. The following three access times are used depending on the condition.

- Address access time (t_{acc}): Time until valid data is output after an address has been determined (however, after \overline{CE}).
- \overline{CE} access time ($t_{c\bar{e}}$): Time until valid data is output after \overline{CE} has been determined (however, after address).
- \overline{OE} access time ($t_{o\bar{e}}$): Time until valid data is output after \overline{OE} has been determined (however, \overline{OE} must be input after $t_{acc-t_{o\bar{e}}}$, $t_{c\bar{e}-t_{o\bar{e}}}$ after address and \overline{CE} have been determined).

On power-up, the device is automatically set in the read mode. To read the device without changing address immediately after power application, either execute hardware reset or briefly lower \overline{CE} to V_{IL} from V_{IH} .

For the timing waveform, refer to Timing Waveform for Read Cycle (1).

Write Operation

The operation of the device is controlled by writing commands to the registers. The command register is a function that latches the address and data necessary for executing an instruction and does not occupy the memory area.

If an illegal address or data is written or if an address or data is written in the wrong sequence, the device is reset to the read mode.

Standby Mode

The standby mode is set when V_{IH} is input to the \overline{CE} . The current consumption in the standby mode can be lowered to $5\ \mu\text{A}$ or less in two ways.

One is to use \overline{CE} and \overline{RESET} . Input $V_{CC} \pm 0.3\ \text{V}$ to \overline{CE} and \overline{RESET} . However, while automatic programming or erasing is being executed, the operating supply current (I_{cc2}) does not decrease to $5\ \mu\text{A}$ or lower even if $\overline{CE} = V_{IH}$. If a read operation is executed in the standby mode, data is output at \overline{CE} access time.

The other is to input $\text{GND} \pm 0.3\ \text{V}$ to the \overline{RESET} . At this time, the level of \overline{CE} is V_{IH} or V_{IL} . In this case, t_{RH} is required for the device to return to the read mode from the standby mode.

For the timing waveform, refer to Timing Waveform for Read Cycle (2).

Hardware Reset Pin

The device is reset to the read mode if V_{IL} is input to the \overline{RESET} for the duration of t_{RP} and V_{IH} for the duration of t_{RH} . While V_{IL} is being input to the \overline{RESET} , all commands are ignored, and the output pins go into a Hi-Z state. If the voltage on \overline{RESET} is kept to $\text{GND} \pm 0.2\ \text{V}$ at this time, the current consumption can be lowered to $5\ \mu\text{A}$ or less. If V_{IH} is input to the \overline{RESET} , t_{READY} is required until data is output.

For the timing waveform, refer to Timing Waveform for Read Cycle (2).

Output Disable Mode

Output from the device is disabled (Hi-Z state) if V_{IH} is input to the \overline{OE} .

Sector Group Protection

Protect the sector group by using a command. \overline{OE} or \overline{WE} control is no need.

Temporary Sector Group Unprotect

Protection of a sector group can be temporarily canceled. When V_{ID} is input to \overline{RESET} , the temporary sector group unprotect mode is set. If a protected sector is selected in this mode, it can be programmed or erased. If the mode is canceled, the sector group is protected again.

For the timing waveform, refer to Timing Waveform for Temporary Sector Group Unprotect.

Product ID

Read the product ID code by using a command.

Automatic Sleep Mode

The automatic sleep mode is used to reduce the power consumption substantially during a read operation.

If an address is held longer than the minimum read cycle time (t_{RC}), the sleep mode (low power consumption mode) is automatically set. In this mode, the output data is latched and continuously output.

In the automatic sleep mode, \overline{CE} , \overline{WE} , and \overline{OE} do not have to be controlled. At this time, the current consumption decreases to $5\ \mu\text{A}$ or less. During dual operation, however, the current consumption is power supply current (I_{cc6} , I_{cc7}).

If the address is changed, the automatic sleep mode is canceled automatically, the device returns to the read mode, and the data of the newly input address is output.

Boot Block Sector Protect

The boot block sector protect mode protects the two sectors of the boot block. This mode is set when V_{IL} is input to \overline{WP} (ACC). If V_{IL} is input to \overline{WP} (ACC) even in the temporary sector group unprotect mode, the boot block remains protected and protection of the other sectors is temporarily canceled.

Accelerated Mode

This mode is used to program the device at high speed, and the programming time can be shortened to about 60%. To program the device in the accelerated mode, input VACC to \overline{WP} (ACC) and use an unlock bypass program command. Therefore, ordinary commands can be used for programming or detection of completion of programming. If VACC is input to \overline{WP} (ACC), the device is automatically set in the unlock bypass mode. Therefore, the unlock bypass set command and reset command are not necessary. The accelerated mode is automatically canceled if the input of VACC to \overline{WP} (ACC) is stopped.

In the accelerated mode, protection of the sector group is temporarily canceled. Exercise care in programming the device at this time. For the timing waveform, refer to Timing Waveform for Accelerated Mode.

Dual Operation

This device can execute a program or erase operation and a read operation simultaneously. By selecting bank 1 or 2 by changing the bank address, one bank can execute a read operation while the other bank is executing a program or erase operation. When changing the bank address, no wait cycle is necessary. Note that two or more program or erase operation. When changing the bank address, no wait cycle is necessary. Note that two or more operations cannot be executed at the same time in the same bank.

The following table shows the combinations of bank operations.

For the timing waveform, refer to Timing Waveform for Dual Operation.

Table 2. Dual Operation

Case	Operation of Bank 1	Operation of Bank 2
1	Read mode	Read mode
2	Read mode	Product ID
3	Read mode	Program (Note 1)
4	Read mode	Erase (Note 2)
5	Product ID	Read mode
6	Program (Note 1)	Read mode
7	Erase (Note 2)	Read mode

Notes 1. The program operation is suspended by the program suspend command, and addresses not being programmed to at this time can only be read.

2. The erase operation is suspended by the erase suspend command. The sector not erased at this time can be read or programmed.

Table 3. A29DL323 Top Boot Block Sector Address Table

Bank	Sector	Sector Address Table									Sector Size (Kbytes/ Kwords)	Address Range (in hexadecimal)	
		Bank Address Table										Byte Mode (x 8)	Word Mode (x16)
		A20	A19	A18	A17	A16	A15	A14	A13	A12			
Bank 1	SA70	1	1	1	1	1	1	1	1	1	8/4	3FFFFFFH-3FE000H	1FFFFFFH-1FF000H
	SA69	1	1	1	1	1	1	1	1	0	8/4	3DFFFFFFH-3FC000H	1FEFFFFFFH-1FE000H
	SA68	1	1	1	1	1	1	1	0	1	8/4	3FBFFFFFFH-3FA000H	1FDFFFFFFH-1FD000H
	SA67	1	1	1	1	1	1	1	0	0	8/4	3F9FFFFFFH-3F8000H	1FCFFFFFFH-1FC000H
	SA66	1	1	1	1	1	1	0	1	1	8/4	3F7FFFFFFH-3F6000H	1FBFFFFFFH-1FB000H
	SA65	1	1	1	1	1	1	0	1	0	8/4	3F5FFFFFFH-3F4000H	1FAFFFFFFH-1FA000H
	SA64	1	1	1	1	1	1	0	0	1	8/4	3F3FFFFFFH-3F2000H	1F9FFFFFFH-1F9000H
	SA63	1	1	1	1	1	1	0	0	0	8/4	3F1FFFFFFH-3F0000H	1F8FFFFFFH-1F8000H
	SA62	1	1	1	1	1	0	X	X	X	64/32	3EFFFFFFH-3E0000H	1F7FFFFFFH-1F0000H
	SA61	1	1	1	1	0	1	X	X	X	64/32	3DFFFFFFH-3D0000H	1EFFFFFFH-1E8000H
	SA60	1	1	1	1	0	0	X	X	X	64/32	3CFFFFFFH-3C0000H	1E7FFFFFFH-1E0000H
	SA59	1	1	1	0	1	1	X	X	X	64/32	3BFFFFFFH-3B0000H	1DFFFFFFH-1D8000H
	SA58	1	1	1	0	1	0	X	X	X	64/32	3AFFFFFFH-3A0000H	1D7FFFFFFH-1D0000H
	SA57	1	1	1	0	0	1	X	X	X	64/32	39FFFFFFH-390000H	1CFFFFFFH-1C8000H
	SA56	1	1	1	0	0	0	X	X	X	64/32	38FFFFFFH-380000H	1C7FFFFFFH-1C0000H
	SA55	1	1	0	1	1	1	X	X	X	64/32	37FFFFFFH-370000H	1BFFFFFFH-1B8000H
	SA54	1	1	0	1	1	0	X	X	X	64/32	36FFFFFFH-360000H	1B7FFFFFFH-1B0000H
	SA53	1	1	0	1	0	1	X	X	X	64/32	35FFFFFFH-350000H	1AFFFFFFH-1A8000H
	SA52	1	1	0	1	0	0	X	X	X	64/32	34FFFFFFH-340000H	1A7FFFFFFH-1A0000H
	SA51	1	1	0	0	1	1	X	X	X	64/32	33FFFFFFH-330000H	19FFFFFFH-198000H
SA50	1	1	0	0	1	0	X	X	X	64/32	32FFFFFFH-320000H	197FFFFFFH-190000H	
SA49	1	1	0	0	0	1	X	X	X	64/32	31FFFFFFH-310000H	18FFFFFFH-188000H	
SA48	1	1	0	0	0	0	X	X	X	64/32	30FFFFFFH-300000H	187FFFFFFH-180000H	
Bank 2	SA47	1	0	1	1	1	1	X	X	X	64/32	2FFFFFFH-2F0000H	17FFFFFFH-178000H
	SA46	1	0	1	1	1	0	X	X	X	64/32	2EFFFFFFH-2E0000H	177FFFFFFH-170000H
	SA45	1	0	1	1	0	1	X	X	X	64/32	2DFFFFFFH-2D0000H	16FFFFFFH-168000H
	SA44	1	0	1	1	0	0	X	X	X	64/32	2CFFFFFFH-2C0000H	167FFFFFFH-160000H
	SA43	1	0	1	0	1	1	X	X	X	64/32	2BFFFFFFH-2B0000H	15FFFFFFH-158000H
	SA42	1	0	1	0	1	0	X	X	X	64/32	2AFFFFFFH-2A0000H	157FFFFFFH-150000H
	SA41	1	0	1	0	0	1	X	X	X	64/32	29FFFFFFH-290000H	14FFFFFFH-148000H
	SA40	1	0	1	0	0	0	X	X	X	64/32	28FFFFFFH-280000H	147FFFFFFH-140000H
	SA39	1	0	0	1	1	1	X	X	X	64/32	27FFFFFFH-270000H	13FFFFFFH-138000H
	SA38	1	0	0	1	1	0	X	X	X	64/32	26FFFFFFH-260000H	137FFFFFFH-130000H
	SA37	1	0	0	1	0	1	X	X	X	64/32	25FFFFFFH-250000H	12FFFFFFH-128000H
	SA36	1	0	0	1	0	0	X	X	X	64/32	24FFFFFFH-240000H	127FFFFFFH-120000H
	SA35	1	0	0	0	1	1	X	X	X	64/32	23FFFFFFH-230000H	11FFFFFFH-118000H



Table 3. A29DL323 Top Boot Block Sector Address Table (continued)

Bank	Sector	Sector Address Table									Sector Size (Kbytes/ Kwords)	Address Range (in hexadecimal)	
		Bank Address Table						A14	A13	A12		Byte Mode (x 8)	Word Mode (x16)
		A20	A19	A18	A17	A16	A15						
Bank 2	SA34	1	0	0	0	1	0	X	X	X	64/32	22FFFFH-220000H	117FFFH-110000H
	SA33	1	0	0	0	1	1	X	X	X	64/32	21FFFFH-210000H	10FFFFH-108000H
	SA32	1	0	0	0	0	0	X	X	X	64/32	20FFFFH-200000H	107FFFH-100000H
	SA31	0	1	1	1	1	1	X	X	X	64/32	1FFFFFH-1F0000H	0FFFFFH-0F8000H
	SA30	0	1	1	1	1	0	X	X	X	64/32	1EFFFFH-1E0000H	0F7FFFH-0F0000H
	SA29	0	1	1	1	0	1	X	X	X	64/32	1DFFFFH-1D0000H	0EFFFFH-0E8000H
	SA28	0	1	1	1	0	0	X	X	X	64/32	1CFFFFH-1C0000H	0E7FFFH-0E0000H
	SA27	0	1	1	0	1	1	X	X	X	64/32	1BFFFFH-1B0000H	0DFFFFH-0D8000H
	SA26	0	1	1	0	1	0	X	X	X	64/32	1AFFFFH-1A0000H	0D7FFFH-0D0000H
	SA25	0	1	1	0	0	1	X	X	X	64/32	19FFFFH-190000H	0CFFFFH-0C8000H
	SA24	0	1	1	0	0	0	X	X	X	64/32	18FFFFH-180000H	0C7FFFH-0C0000H
	SA23	0	1	0	1	1	1	X	X	X	64/32	17FFFFH-170000H	0BFFFFH-0B8000H
	SA22	0	1	0	1	1	0	X	X	X	64/32	16FFFFH-160000H	0B7FFFH-0B0000H
	SA21	0	1	0	1	0	1	X	X	X	64/32	15FFFFH-150000H	0AFFFFH-0A8000H
	SA20	0	1	0	1	0	0	X	X	X	64/32	14FFFFH-140000H	0A7FFFH-0A0000H
	SA19	0	1	0	0	1	1	X	X	X	64/32	13FFFFH-130000H	09FFFFH-098000H
	SA18	0	1	0	0	1	0	X	X	X	64/32	12FFFFH-120000H	097FFFH-090000H
	SA17	0	1	0	0	0	1	X	X	X	64/32	11FFFFH-110000H	08FFFFH-088000H
	SA16	0	0	1	0	0	0	X	X	X	64/32	10FFFFH-100000H	087FFFH-080000H
	SA15	0	0	1	1	1	1	X	X	X	64/32	0FFFFFH-0F0000H	07FFFFH-078000H
	SA14	0	0	1	1	1	0	X	X	X	64/32	0EFFFFH-0E0000H	077FFFH-070000H
	SA13	0	0	1	1	0	1	X	X	X	64/32	0DFFFFH-0D0000H	06FFFFH-068000H
	SA12	0	0	1	1	0	0	X	X	X	64/32	0CFFFFH-0C0000H	067FFFH-060000H
	SA11	0	0	1	0	1	1	X	X	X	64/32	0BFFFFH-0B0000H	05FFFFH-058000H
	SA10	0	0	1	0	1	0	X	X	X	64/32	0AFFFFH-0A0000H	057FFFH-050000H
	SA9	0	0	1	0	0	1	X	X	X	64/32	09FFFFH-090000H	04FFFFH-048000H
	SA8	0	0	1	0	0	0	X	X	X	64/32	08FFFFH-080000H	047FFFH-040000H
	SA7	0	0	0	1	1	1	X	X	X	64/32	07FFFFH-070000H	03FFFFH-038000H
	SA6	0	0	0	1	1	0	X	X	X	64/32	06FFFFH-060000H	037FFFH-030000H
	SA5	0	0	0	1	0	1	X	X	X	64/32	05FFFFH-050000H	02FFFFH-028000H
	SA4	0	0	0	1	0	0	X	X	X	64/32	04FFFFH-040000H	027FFFH-020000H
	SA3	0	0	0	0	1	1	X	X	X	64/32	03FFFFH-030000H	01FFFFH-018000H
SA2	0	0	0	0	1	0	X	X	X	64/32	02FFFFH-020000H	017FFFH-010000H	
SA1	0	0	0	0	0	1	X	X	X	64/32	01FFFFH-010000H	00FFFFH-008000H	
SA0	0	0	0	0	0	0	X	X	X	64/32	00FFFFH-000000H	007FFFH-000000H	

Table 4. A29DL323 Bottom Boot Block Sector Address Table

Bank	Sector	Sector Address Table									Sector Size (Kbytes/ Kwords)	Address Range (in hexadecimal)	
		Bank Address Table										Byte Mode (x 8)	Word Mode (x16)
		A20	A19	A18	A17	A16	A15	A14	A13	A12			
Bank 2	SA70	1	1	1	1	1	1	X	X	X	64/32	3FFFFFFH-3F0000H	1FFFFFFH-1F8000H
	SA69	1	1	1	1	1	0	X	X	X	64/32	3EFFFFFFH-3E0000H	1F7FFFFH-1F0000H
	SA68	1	1	1	1	0	1	X	X	X	64/32	3DFFFFFFH-3D0000H	1EFFFFFFH-1E8000H
	SA67	1	1	1	1	0	0	X	X	X	64/32	3CFFFFFFH-3C0000H	1E7FFFFH-1E0000H
	SA66	1	1	1	0	1	1	X	X	X	64/32	3BFFFFFFH-3B0000H	1DFFFFFFH-1D8000H
	SA65	1	1	1	0	1	0	X	X	X	64/32	3AFFFFFFH-3A0000H	1D7FFFFH-1D0000H
	SA64	1	1	1	0	0	1	X	X	X	64/32	39FFFFFFH-390000H	1CFFFFFFH-1C8000H
	SA63	1	1	1	0	0	0	X	X	X	64/32	38FFFFFFH-380000H	1C7FFFFH-1C0000H
	SA62	1	1	0	1	1	1	X	X	X	64/32	37FFFFFFH-370000H	1BFFFFFFH-1B8000H
	SA61	1	1	0	1	1	0	X	X	X	64/32	36FFFFFFH-360000H	1B7FFFFH-1B0000H
	SA60	1	1	0	1	0	1	X	X	X	64/32	35FFFFFFH-350000H	1AFFFFFFH-1A8000H
	SA59	1	1	0	1	0	0	X	X	X	64/32	34FFFFFFH-340000H	1A7FFFFH-1A0000H
	SA58	1	1	0	0	1	1	X	X	X	64/32	33FFFFFFH-330000H	19FFFFFFH-198000H
	SA57	1	1	0	0	1	0	X	X	X	64/32	32FFFFFFH-320000H	197FFFFH-190000H
	SA56	1	1	0	0	0	1	X	X	X	64/32	31FFFFFFH-310000H	18FFFFFFH-188000H
	SA55	1	1	0	0	0	0	X	X	X	64/32	30FFFFFFH-300000H	187FFFFH-180000H
	SA54	1	0	1	1	1	1	X	X	X	64/32	2FFFFFFH-2F0000H	17FFFFFFH-178000H
	SA53	1	0	1	1	1	0	X	X	X	64/32	2EFFFFFFH-2E0000H	177FFFFH-170000H
	SA52	1	0	1	1	0	1	X	X	X	64/32	2DFFFFFFH-2D0000H	16FFFFFFH-168000H
	SA51	1	0	1	1	0	0	X	X	X	64/32	2CFFFFFFH-2C0000H	167FFFFH-160000H
	SA50	1	0	1	0	1	1	X	X	X	64/32	2BFFFFFFH-2B0000H	15FFFFFFH-158000H
	SA49	1	0	1	0	1	0	X	X	X	64/32	2AFFFFFFH-2A0000H	157FFFFH-150000H
	SA48	1	0	1	0	0	1	X	X	X	64/32	29FFFFFFH-290000H	14FFFFFFH-148000H
	SA47	1	0	1	0	0	0	X	X	X	64/32	28FFFFFFH-280000H	147FFFFH-140000H
	SA46	1	0	0	1	1	1	X	X	X	64/32	27FFFFFFH-270000H	13FFFFFFH-138000H
	SA45	1	0	0	1	1	0	X	X	X	64/32	26FFFFFFH-260000H	137FFFFH-130000H
	SA44	1	0	0	1	0	1	X	X	X	64/32	25FFFFFFH-250000H	12FFFFFFH-128000H
	SA43	1	0	0	1	0	0	X	X	X	64/32	24FFFFFFH-240000H	127FFFFH-120000H
	SA42	1	0	0	0	1	1	X	X	X	64/32	23FFFFFFH-230000H	11FFFFFFH-118000H
	SA41	1	0	0	0	1	0	X	X	X	64/32	22FFFFFFH-220000H	117FFFFH-110000H
	SA40	1	0	0	0	0	1	X	X	X	64/32	21FFFFFFH-210000H	10FFFFFFH-108000H
	SA39	1	0	0	0	0	0	X	X	X	64/32	20FFFFFFH-200000H	107FFFFH-100000H
	SA38	0	1	1	1	1	1	X	X	X	64/32	1FFFFFFH-1F0000H	0FFFFFFH-0F8000H
	SA37	0	1	1	1	1	0	X	X	X	64/32	1EFFFFFFH-1E0000H	0F7FFFFH-0F0000H
	SA36	0	1	1	1	0	1	X	X	X	64/32	1DFFFFFFH-1D0000H	0EFFFFFFH-0E8000H
	SA35	0	1	1	1	0	0	X	X	X	64/32	1CFFFFFFH-1C0000H	0E7FFFFH-0E0000H



Table 4. A29DL323 Bottom Boot Block Sector Address Table (continued)

Bank	Sector	Sector Address Table									Sector Size (Kbytes/ Kwords)	Address Range (in hexadecimal)	
		Bank Address Table										Byte Mode (x 8)	Word Mode (x16)
		A20	A19	A18	A17	A16	A15	A14	A13	A12			
Bank 2	SA34	0	1	1	0	1	1	X	X	X	64/32	1BFFFFH-1B0000H	0DFFFFH- 0D8000H
	SA33	0	1	1	0	1	0	X	X	X	64/32	1AFFFFH-1A0000H	0D7FFFFH- 0D0000H
	SA32	0	1	1	0	0	1	X	X	X	64/32	19FFFFH-190000H	0CFFFFH-0C8000H
	SA31	0	1	1	0	0	0	X	X	X	64/32	18FFFFH-180000H	0C7FFFFH-0C0000H
	SA30	0	1	0	1	1	1	X	X	X	64/32	17FFFFH-170000H	0BFFFFH-0B8000H
	SA29	0	1	0	1	1	0	X	X	X	64/32	16FFFFH-160000H	0B7FFFFH-0B0000H
	SA28	0	1	0	1	0	1	X	X	X	64/32	15FFFFH-150000H	0AFFFFH-0A8000H
	SA27	0	1	0	1	0	0	X	X	X	64/32	14FFFFH-140000H	0AFFFFH-0A0000H
	SA26	0	1	0	0	1	1	X	X	X	64/32	13FFFFH-130000H	09FFFFH-098000H
	SA25	0	1	0	0	1	0	X	X	X	64/32	12FFFFH- 120000H	097FFFFH- 090000H
	SA24	0	1	0	0	0	1	X	X	X	64/32	11FFFFH-110000H	08FFFFH-088000H
	SA23	0	1	0	0	0	0	X	X	X	64/32	10FFFFH-100000H	087FFFFH-080000H
Bank 1	SA22	0	0	1	1	1	1	X	X	X	64/32	0FFFFH-0F0000H	07FFFFH-078000H
	SA21	0	0	1	1	1	0	X	X	X	64/32	0EFFFFH-0E0000H	077FFFFH-070000H
	SA20	0	0	1	1	0	1	X	X	X	64/32	0DFFFFH-0D0000H	06FFFFH-068000H
	SA19	0	0	1	1	0	0	X	X	X	64/32	0CFFFFH-0C0000H	067FFFFH-060000H
	SA18	0	0	1	0	1	1	X	X	X	64/32	0BFFFFH-0B0000H	05FFFFH-058000H
	SA17	0	0	1	0	1	0	X	X	X	64/32	0AFFFFH-0A0000H	057FFFFH-050000H
	SA16	0	0	1	0	0	1	X	X	X	64/32	09FFFFH-090000H	04FFFFH-048000H
	SA15	0	0	1	0	0	0	X	X	X	64/32	08FFFFH-080000H	047FFFFH-040000H
	SA14	0	0	0	1	1	1	X	X	X	64/32	07FFFFH-070000H	03FFFFH-038000H
	SA13	0	0	0	1	1	0	X	X	X	64/32	06FFFFH-060000H	037FFFFH-030000H
	SA12	0	0	0	1	0	1	X	X	X	64/32	05FFFFH-050000H	02FFFFH-028000H
	SA11	0	0	0	1	0	0	X	X	X	64/32	04FFFFH-040000H	027FFFFH-020000H
	SA10	0	0	0	0	1	1	X	X	X	64/32	03FFFFH-030000H	01FFFFH-018000H
	SA9	0	0	0	0	1	0	X	X	X	64/32	02FFFFH-020000H	017FFFFH-010000H
	SA8	0	0	0	0	0	1	X	X	X	64/32	01FFFFH-010000H	00FFFFH-008000H
	SA7	0	0	0	0	0	0	1	1	1	64/32	00FFFFH-00E000H	007FFFFH-007000H
	SA6	0	0	0	0	1	1	1	1	0	64/32	00DFFFFH-00C000H	006FFFFH-006000H
	SA5	0	0	0	0	0	0	1	0	1	64/32	00BFFFFH-00A000H	005FFFFH-005000H
SA4	0	0	0	0	0	0	1	0	0	64/32	009FFFFH-008000H	004FFFFH-004000H	
SA3	0	0	0	0	0	0	0	1	1	64/32	007FFFFH-006000H	003FFFFH-003000H	
SA2	0	0	0	0	0	0	0	1	0	64/32	005FFFFH-004000H	002FFFFH-002000H	
SA1	0	0	0	0	0	0	0	0	1	64/32	003FFFFH-002000H	001FFFH-001000H	
SA0	0	0	0	0	0	0	0	0	0	64/32	001FFFFH-000000H	000FFFFH-000000H	



Table 5. A29DL323 Top Boot Sector Group Address Table

Sector Group	A20	A19	A18	A17	A16	A15	A14	A13	A12	Size	Sector
SGA0	0	0	0	0	0	0	X	X	X	64 KB (1 Sector)	FSA0
SGA1	0	0	0	0	0	1	X	X	X	192 KB (3 Sectors)	FSA1–FSA3
					1	0					
					1	1					
SGA2	0	0	0	1	X	X	X	X	X	256 KB (4 Sectors)	FSA4–FSA7
SGA3	0	0	0	1	X	X	X	X	X	256 KB (4 Sectors)	FSA8–FSA11
SGA4	0	0	1	1	X	X	X	X	X	256 KB (4 Sectors)	FSA12–FSA15
SGA5	0	1	0	0	X	X	X	X	X	256 KB (4 Sectors)	FSA16–FSA19
SGA6	0	1	0	1	X	X	X	X	X	256 KB (4 Sectors)	FSA20–FSA23
SGA7	0	1	1	0	X	X	X	X	X	256 KB (4 Sectors)	FSA24–FSA27
SGA8	0	1	1	1	X	X	X	X	X	256 KB (4 Sectors)	FSA28–FSA31
SGA9	0	1	1	1	X	X	X	X	X	256 KB (4 Sectors)	FSA32–FSA35
SGA10	1	0	0	1	X	X	X	X	X	256 KB (4 Sectors)	FSA36–FSA39
SGA11	1	0	1	0	X	X	X	X	X	256 KB (4 Sectors)	FSA40–FSA43
SGA12	1	0	1	1	X	X	X	X	X	256 KB (4 Sectors)	FSA44–FSA47
SGA13	1	1	0	0	X	X	X	X	X	256 KB (4 Sectors)	FSA48–FSA51
SGA14	1	1	0	1	X	X	X	X	X	256 KB (4 Sectors)	FSA52–FSA55
SGA15	1	1	1	0	X	X	X	X	X	256 KB (4 Sectors)	FSA56–FSA59
SGA16	1	1	1	1	0	0	X	X	X	192 KB (3 Sectors)	FSA60–FSA62
					0	1					
					1	0					
SGA17	1	1	1	1	1	1	0	0	0	8 KB (1 Sector)	FSA63
SGA18	1	1	1	1	1	1	0	0	1	8 KB (1 Sector)	FSA64
SGA19	1	1	1	1	1	1	0	1	0	8 KB (1 Sector)	FSA65
SGA20	1	1	1	1	1	1	0	1	1	8 KB (1 Sector)	FSA66
SGA21	1	1	1	1	1	1	1	0	0	8 KB (1 Sector)	FSA67
SGA22	1	1	1	1	1	1	1	0	1	8 KB (1 Sector)	FSA68
SGA23	1	1	1	1	1	1	1	1	0	8 KB (1 Sector)	FSA69
SGA24	1	1	1	1	1	1	1	1	1	8 KB (1 Sector)	FSA70

Remark X: V_{IH} or V_{IL}



Table 6. A29DL323 Bottom Boot Sector Group Address Table

Sector Group	A20	A19	A18	A17	A16	A15	A14	A13	A12	Size	Sector
SGA0	0	0	0	0	0	0	0	0	0	8 KB (1 Sector)	FSA0
SGA1	0	0	0	0	0	0	0	0	1	8 KB (1 Sector)	FSA1
SGA2	0	0	0	0	0	0	0	1	0	8 KB (1 Sector)	FSA2
SGA3	0	0	0	0	0	0	0	1	1	8 KB (1 Sector)	FSA3
SGA4	0	0	0	0	0	0	1	0	0	8 KB (1 Sector)	FSA4
SGA5	0	0	0	0	0	0	1	0	1	8 KB (1 Sector)	FSA5
SGA6	0	0	0	0	0	0	1	1	0	8 KB (1 Sector)	FSA6
SGA7	0	0	0	0	0	0	1	1	1	8 KB (1 Sector)	FSA7
SGA8	0	0	0	0	0	1	X	X	X	192 KB (3 Sectors)	FSA8–FSA10
					1	0					
					1	1					
SGA9	0	0	0	1	X	X	X	X	X	256 KB (4 Sectors)	FSA11–FSA14
SGA10	0	0	1	0	X	X	X	X	X	256 KB (4 Sectors)	FSA15–FSA18
SGA11	0	0	1	1	X	X	X	X	X	256 KB (4 Sectors)	FSA19–FSA22
SGA12	0	1	0	0	X	X	X	X	X	256 KB (4 Sectors)	FSA23–FSA26
SGA13	0	1	0	1	X	X	X	X	X	256 KB (4 Sectors)	FSA27–FSA30
SGA14	0	1	1	0	X	X	X	X	X	256 KB (4 Sectors)	FSA31–FSA34
SGA15	0	1	1	1	X	X	X	X	X	256 KB (4 Sectors)	FSA35–FSA38
SGA16	1	0	0	0	X	X	X	X	X	256 KB (4 Sectors)	FSA39–FSA42
SGA17	1	0	0	1	X	X	X	X	X	256 KB (4 Sectors)	FSA43–FSA46
SGA18	1	0	1	0	X	X	X	X	X	256 KB (4 Sectors)	FSA47–FSA50
SGA19	1	0	1	1	X	X	X	X	X	256 KB (4 Sectors)	FSA51–FSA54
SGA20	1	1	0	0	X	X	X	X	X	256 KB (4 Sectors)	FSA55–FSA58
SGA21	1	1	0	1	X	X	X	X	X	256 KB (4 Sectors)	FSA59–FSA62
SGA22	1	1	1	0	X	X	X	X	X	256 KB (4 Sectors)	FSA63–FSA66
SGA23	1	1	1	1	0	0	X	X	X	192 KB (3 Sector)	FSA67–FSA69
					0	1					
					1	0					
SGA24	1	1	1	1	1	1	X	X	X	64 KB (1 Sector)	FSA70

Remark X: V_{IH} or V_{IL}

Table 7. A29DL323 Product ID Code (Manufacture Code / Device Code)

Product ID Code			Input					Output															HEX		
			A12 to A20	A6	A1	A0	A-1 Note 1	I/O ₁₅	I/O ₁₄	I/O ₁₃	I/O ₁₂	I/O ₁₁	I/O ₁₀	I/O ₉	I/O ₈	I/O ₇	I/O ₆	I/O ₅	I/O ₄	I/O ₃	I/O ₂	I/O ₁		I/O ₀	
Manufacturer Code			X	V _{IL}	V _{IL}	V _{IL}	V _{IL}	0	0	0	0	0	0	0	0	0	0	0	0	0	0	0	0	10H	
Device Code	BYTE mode	Top Boot	X	V _{IL}	V _{IL}	V _{IL}	V _{IL}	Hi-Z	Hi-Z	Hi-Z	Hi-Z	Hi-Z	Hi-Z	Hi-Z	Hi-Z	0	1	0	1	0	0	0	0	50H	
		Bottom Boot						Hi-Z	Hi-Z	Hi-Z	Hi-Z	Hi-Z	Hi-Z	Hi-Z	Hi-Z	0	1	0	1	0	0	1	1	53H	
	WORD mode	Top Boot	X	V _{IL}	V _{IL}	V _{IH}	X	0	0	1	0	0	0	0	1	0	0	1	0	1	0	0	0	0	2250H
		Bottom Boot						0	0	1	0	0	0	0	1	0	0	1	0	1	0	0	1	1	2253H
Sector Group Protection			Sector Group Address	V _{IL}	V _{IH}	V _{IL}	V _{IL}	0	0	0	0	0	0	0	0	0	0	0	0	0	0	0	0	01H ^{Note2}	

Notes: 1. A-1 is valid only in the BYTE mode. I/O₈ to I/O₁₄ go into a high-impedance state in the BYTE mode, and I/O₁₅ is A-1 of the lowest address.

2. If 01H is output, the sector group is protected. If 00H is output, the sector group is unprotected.

Remark X: V_{IH} or V_{IL}

Sector Group Protection

This command performs sector group protection.

By applying V_{DD} to \overline{RESET} and writing 60H to any address, the device enters the sector group protection mode.

Sector group protection is started by inputting the sector group address of the sector group to be protected to A12 to A20, inputting (A6, A1, A0) = (V_{IL} , V_{IH} , V_{IL}), and writing 60H. After a timeout of 250 μ s, sector group protection is completed.

Next, with the sector group address input to A12 to A20, the device enters the sector group protection verify mode by inputting (A6, A1, A0) = (V_{IL} , V_{IH} , V_{IL}), and writing 40H. When read is performed in this state, the sector group protection verify result is output to I/O0. If "1" is output to I/O0, the verified sector group is protected. If "1" was not output to I/O0, sector group protection failed, so perform sector group protection again.

For the timing waveform and flow chart, refer to Timing Waveform for Sector Group Protection and Figure 1.

Sector Group Unprotect

This command performs sector group unprotect.

Sector group unprotect is performed for all sector group. Unprotect cannot be performed for specific sector group. Moreover, all sector groups must be protected prior to unprotect.

The device enters the sector group unprotect mode by applying V_{DD} to \overline{RESET} and writing 60H to any address.

If unprotected sector group exist, first perform sector group protection for these sector groups. To protect a sector group, input the sector group address of the sector group to be protected to the sector group address input pin, input (A6, A1, A0) = (V_{IL} , V_{IH} , V_{IL}), and write 60H (refer to Sector Group Protection).

Sector group unprotect is started by inputting (A6, A1, A0) = (V_{IH} , V_{IH} , V_{IL}), and writing 60H to any address.

Following a timeout of 15 ms, sector group unprotect is completed.

Unprotect verification must be performed for each sector group.

The device enters the sector group unprotect verification mode by inputting the sector group address to input pin of sector group address and writing 40H, with input (A6, A1, A0) = (V_{IH} , V_{IH} , V_{IL}).

If reading is performed in this state, the sector group unprotect verification result is output to I/O0. If the verified sector group is unprotected, "0" is output to I/O0. If "0" is not output to I/O0, this means that unprotect failed, so perform sector group unprotect again.

For the flow chart, refer to Figure 2. Sector Group Unprotect Flow Chart.

Query

The dual operation flash memory conforms to CFI (Common Flash memory Interface). CFI enables information about a device such as the device specifications, memory density, and supply voltage to be read. Therefore, the software of the host system can support the software algorithm of a specific vendor used by a device by using the CFI. For details, refer to the CFI specifications.

By writing the Query command (98H) and giving an address, the device information corresponding to that address can be read. If the device information is read in the WORD mode (16 bits), the upper bytes of data (I/O15 to I/O8) are "0".

To end the Query mode, writes the read / reset command.

Extra One Time Protect Sector Entry

The dual operation flash memory has a sector area that has One Time Protect function. This area does not allow code that has been written to the area to be changed. This area can be programmed or erased until it is protected.

Once it has been protected, however, protection can never be canceled. Therefore, care must be exercised when using this area.

The Extra One Time Protect Sector area has a density of 64 Kbytes and exists at the same addresses as the 8 Kbytes sector. These addresses are 3F0000H to 3FFFFFFH for top boot in the BYTE mode (1F8000H to 1FFFFFFH in the WORD mode), and 000000H to 00FFFFFFH for bottom boot in the BYTE mode (000000H to 007FFFFH in the WORD mode). Because boot block areas (8 Kbytes x 8 sectors) usually appear in the areas of these addresses, the Extra One Time Protect Sector entry command sequence must be written to enter them as the Extra One Time Protect Sector area. The status in which the Extra One Time Protect Sector area appears is the Extra One Time Protect Sector mode.

In the Extra One Time Protect Sector mode, the other sectors, except the boot block area, can be read. In addition, the Extra One Time Protect Sector area can be read, programmed, or erased in this mode. To exit from the Extra One Time Protect Sector mode, the Extra One Time Protect Sector Reset command sequence must be written.

Extra One Time Protect Sector Program

To program data to the Extra One Time Protect Sector area, write the Extra One Time Protect Sector Program command sequence in the Extra One Time Protect Sector mode. This command is no different from the conventional program command except that it must be written in the Extra One Time Protect Sector mode. Therefore, completion of execution of this command is detected in the same manner as the conventional detection method of using I/O7 data polling, I/O6 toggle bit, and $R\overline{Y}/\overline{B\overline{Y}}$. Care must be exercised in selecting a program destination address. If a program destination address other than the one in the Extra One Time Protect Sector area is selected, the data of that address is changed.

Extra One Time Protect Sector Erase

To erase the Extra One Time Protect Sector area, write the Extra One Time Protect Sector erase command sequence in the Extra One Time Protect Sector mode. This command is the same as the conventional sector erase command except that it must be written in the Extra One Time Protect Sector mode. Therefore, completion of execution of this command is detected in the same manner as the conventional detection method of using I/O₇ data polling, I/O₆ toggle bit, and RY/ $\overline{\text{BY}}$. Care must be exercised in selecting a sector address to erase. If a sector address other than the one in the Extra One Time Protect Sector area is selected, the data of that sector is changed.

Extra One Time Protect Sector Protection

The following write operations are used to protect the Extra One Time Protect area during the Extra One Time Protect Sector mode.

Write the sector group protection setup command (60H) in the Extra One Time Protect Sector mode.

. Set (A6, A1, A0) = (V_{IL}, V_{IH}, V_{IL}), and set the sector address that selects the Extra One Time Protect Sector.

. Write the sector group protection command (60H).

Because the sequence is the same as the conventional command sequence to protect a sector group except that the Extra One Time Protect Sector mode must be set and that VID is not input to the $\overline{\text{RESET}}$, the same command sequence can be used.

For details of how to protect a sector group, refer to Sector Group Protection.

If an address other than the one of the Extra One Time Protect Sector area is specified as a sector address, the other sectors are affected. Once the sector has been protected, protection can never be canceled. Exercise utmost care when protecting a sector.

Hardware Data Protection

This device requires two unlock cycles for program / erase command sequence to prevent illegal program / erase. Moreover, a hardware data protect function is provided as follows.

Low VCC Write Inhibit

To prevent an illegal write cycle during VCC transition, the command register and program / erase circuit is disabled and all write cycles are ignored while VCC is V_{LKO} or lower. Write commands are ignored until VCC becomes equal to or greater than V_{LKO}.

Logical Inhibit

The write cycle is inhibited under any of the following conditions : $\overline{\text{OE}} = \text{V}_{\text{IL}}$, $\overline{\text{CE}} = \text{V}_{\text{IH}}$, or $\overline{\text{WE}} = \text{V}_{\text{IH}}$. To start a write cycle, $\overline{\text{CE}} = \text{V}_{\text{IL}}$ and $\overline{\text{WE}} = \text{V}_{\text{IL}}$ must be set while /OE = V_{IH}.

Power-Up Write Inhibit

Even if $\overline{\text{WE}} = \overline{\text{CE}} = \text{V}_{\text{IL}}$ and $\overline{\text{OE}} = \text{V}_{\text{IH}}$ are satisfied at power-up, no commands are accepted at the rising edge of $\overline{\text{WE}}$. The device is automatically reset to the read mode at power ON.

Write Pulse "Glitch" Protection

Because $\overline{\text{OE}}$, $\overline{\text{CE}}$, and /WE reject a noise pulse of 5 ns (typical) or less as an invalid pulse, a write operation is not started.

Sector Group Protection

The dual operation flash memory can be protected by the user in sector group units. For details, refer to Sector Group Protection.

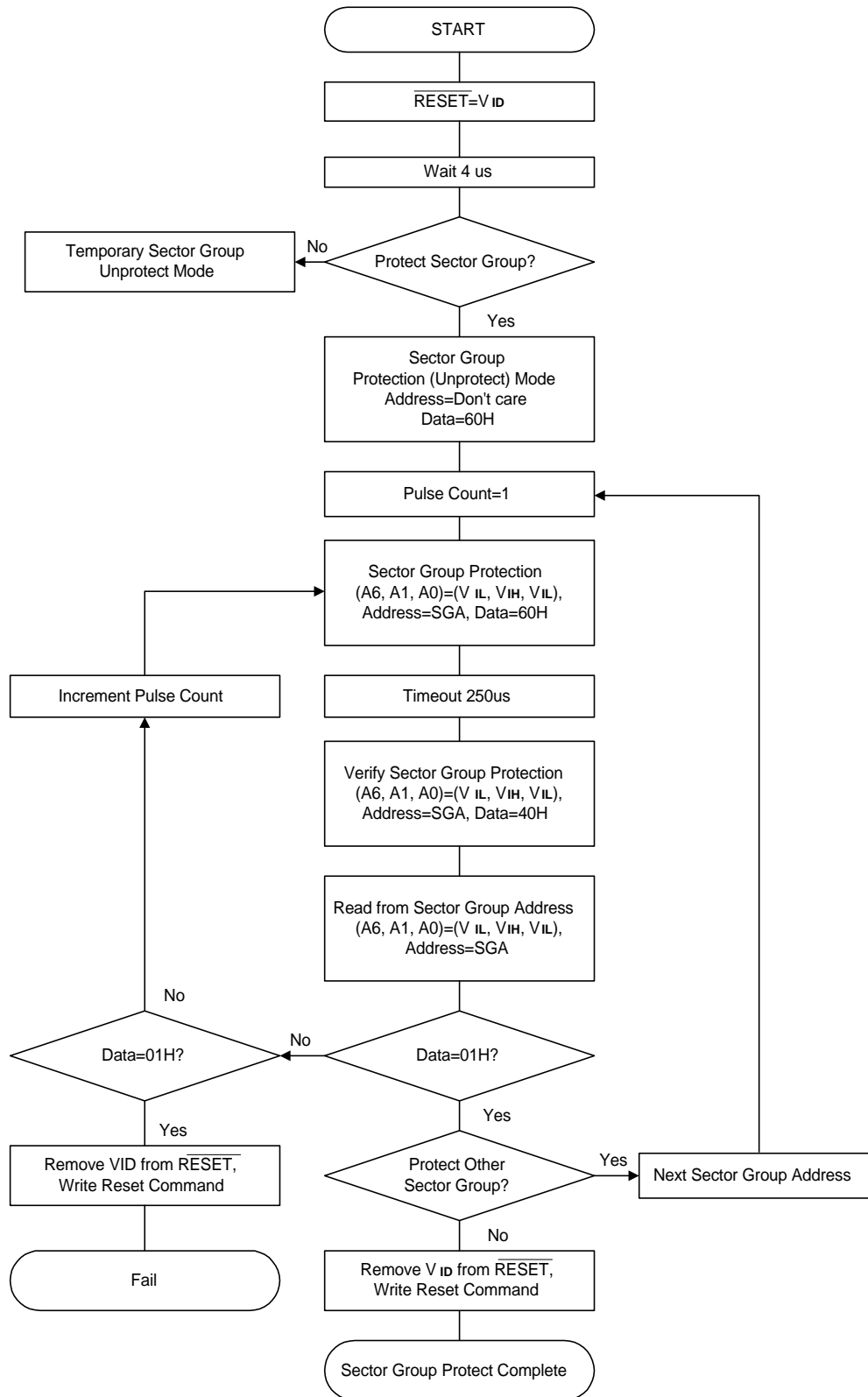
Figure 1. Sector Group Protection Flow Chart



CFI Code List

Address A6 to A0	Data I/O ₁₅ to I/O ₀	Description
10H	0051H	"QRY" (ASCII code)
11H	0052H	
12H	0059H	
13H	0002H	Main command set
14H	0000H	2 : AMD/FJ standard type
15H	0040H	Start address of PRIMARY table
16H	0000H	
17H	0000H	Auxiliary command set
18H	0000H	00H : Not supported
19H	0000H	Start address of auxiliary algorithm table
1AH	0000H	
1BH	0027H	Minimum VCC voltage (program / erase) I/O ₇ to I/O ₄ : 1 V/bit I/O ₃ to I/O ₀ : 100 mV/bit
1CH	0036H	Maximum VCC voltage (program / erase) I/O ₇ to I/O ₄ : 1 V/bit I/O ₃ to I/O ₀ : 100 mV/bit
1DH	0000H	Minimum VPP voltage
1EH	0000H	Maximum VPP voltage
1FH	0004H	Typical word program time (2 ^N μs)
20H	0000H	Typical buffer program time (2 ^N μs)
21H	000AH	Typical sector erase time (2 ^N ms)
22H	0000H	Typical chip erase time (2 ^N ms)
23H	0005H	Maximum word program time (typical time × 2 ^N)
24H	0000H	Maximum buffer program time (typical time × 2 ^N)
25H	0004H	Maximum sector erasing time (typical time × 2 ^N)
26H	0000H	Maximum chip erasing time (typical time × 2 ^N)
27H	0016H	Capacity (2 ^N Bytes)
28H	0002H	I/O information
29H	0000H	2 : x8/x16-bit organization
2AH	0000H	Maximum number of bytes when two banks are programmed (2 ^N)
2BH	0000H	
2CH	0002H	Type of erase block
2DH	0007H	Information about erase block 1 Bit0 to 15 : y = number of sectors Bit16 to 31 : z = size (Z × 256 Bytes)
2EH	0000H	
2FH	0020H	
30H	0000H	
31H	003EH	Information about erase block 2 bit0 to 15 : y = number of sectors bit16 to 31 : z = size (z × 256 Bytes)
32H	0000H	
33H	0000H	
34H	0001H	
40H	0050H	"PRI" (ASCII code)
41H	0052H	
42H	0049H	



CFI Code List (continued)

Address A6 to A0	Data I/O₁₅ to I/O₀	Description
43H	0031H	Main version (ASCII code)
44H	0032H	Minor version (ASCII code)
45H	0000H	Address during command input 00H : Necessary 01H : Unnecessary
46H	0002H	Temporary erase suspend function 00H : Not supported 01H : Read only 02H : Read / Program
47H	0001H	Sector group protection 00H : Not supported 01H : Supported
48H	0001H	Temporary sector group protection 00H : Not supported 01H : Supported
49H	0004H	Sector group protection algorithm
4AH	00XXH	Number of sectors of bank 2 00H : Not supported 30H : A29DL323
4BH	0000H	Burst mode 00H : Not supported
4CH	0000H	Page mode 00H : Not supported
4DH	0085H	Minimum V _{ACC} voltage I/O ₇ to I/O ₄ : 1 V/bit I/O ₃ to I/O ₀ : 100 mV/bit
4EH	0095H	Maximum V _{ACC} voltage I/O ₇ to I/O ₄ : 1 V/bit I/O ₃ to I/O ₀ : 100 mV/bit
4FH	00XXH	Boot organization 02H : Bottom boot (A29DL323UX-XX) 03H : Top boot (A29DL323TX-XX)
50H	0001H	Temporary program suspend function 00H : Not supported 01H : Supported

Command Definitions

Writing Commands

All operations are executed by writing a command. To write a command, the write cycle of a standard microprocessor is used.

The operation of the device is controlled by writing a command to a register. The command register is a function that latches the address and data necessary for executing an instruction and does not occupy the memory area.

If an illegal address or data is written or if an address or data is written in the wrong sequence, the device is reset to the read mode.

Table 8. shows the commands and command sequences.

Read / Reset Command

This command resets the device to the read mode.

The read mode is maintained until the contents of the command register are changed.

Once the device is in the read mode, no command is necessary for reading data. Data read can be performed using the read cycle of a standard microprocessor.

The read mode is maintained until the contents of the command register are changed.

Product ID

The manufacturer code and device code can be read without inputting a high voltage to the address pin.

If a bank address is specified in the third bus cycle and a read operation is started from address xx00H in the fourth bus cycle, manufacturer code 10H is output. If address xx02H (BYTE mode) or xx01H (WORD mode) is read, the device code is output. If a read operation is executed from an address in the bank not specified in the third bus cycle, data of the memory cell is output.

If a read operation is executed starting from address (BA) 02H (WORD mode) or (BA) 04H (BYTE mode), information indicating which sector group is protected can be obtained. If the sector group address is scanned with (A6, A1, A0) = (V_{IL}, V_{IH}, V_{IL}), "1" is output to I/O₀ to indicate that the sector group is protected (for details refer to Sector Group Protection).

The product ID can be read only from the specified bank. To read the manufacturer code, device code, and information on protection of sector group from a bank not specified, write the read / reset command, specify the bank address to be read, and then write the product ID command again. To end the product ID mode, writes the read / reset command. To write the product ID command in the product ID mode, execute the read / reset command once.

Program Command Sequence

This command is used to program data.

Program is performed in 1 byte or 1 word units. Program can be performed regardless of the address sequence, even if the sector limit is exceeded. However, "0" cannot be changed back into "1" through the program operation. If overwriting "1" to "0" is attempted, the program operation is interrupted and "1" is output to I/O₅, or successful program is indicated in data polling, but actually the data is "0" as before.

Following write by command sequence, the pulse required for program is automatically generated inside the device and program verification is automatically performed, so that control from external is not required.

During automatic program, any command other than the program suspend is ignored. However, automatic program is interrupted when hardware reset is performed. Since the programmed data is not guaranteed in this case, reexecute the program command following completion of reset.

Upon completion of automatic program, the device returns to the read mode.

The operation status of automatic program can be determined by using the hardware sequence flags (I/O₇, I/O₆, RY/BY pins).

See sections "I/O₇ (Data Polling)", "I/O₆ (Toggle Bit)", and "RY/BY (Ready / Busy)".

For the timing waveform and flow chart, refer to Timing Waveform for Write Cycle (WE Controlled), Timing Waveform for Write Cycle (CE Controlled) and Figure 3.

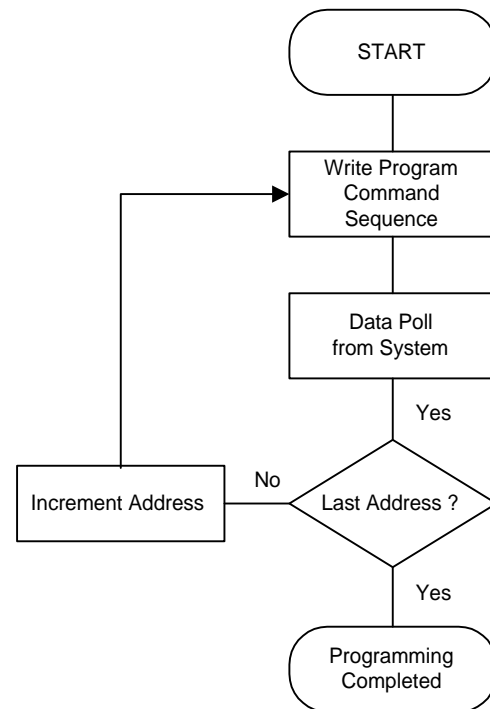

Figure 3. Program Flow Chart

Program Suspend / Resume Commands

This command is used to suspend automatic programming. Addresses not being programmed to while programming is suspended can be read.

Sector erase (including the timeout period) and data program operations can be both suspended. Chip erase operations cannot be suspended.

1 μ s is required between when the command sequence is programmed and when the automatic program operation is suspended.

The execution status of an automatic program operation can be determined using a hardware sequence flag (I/O₇, I/O₆ pins.) refer to I/O₇ (Data polling) and I/O₆ (Toggle Bit).

To resume an automatic program operation, write the resume command (30H) while the operation is suspended.

Caution about Program Suspend / Resume Commands

If automatic program resume and suspend are repeated at intervals of less than 5 μ s, the program operation may not be correctly completed.

Chip Erase Command Sequence

This command is used to erase the entire chip.

Following command sequence write, erase is performed after "0" is written to all memory cells and verification is performed, using the automatic erase function. Program before erase and control from external are not required.

During automatic erase, all commands that have been written are ignored. However, automatic erase is interrupted by hardware reset. Since erase is not guaranteed in this case, execute the chip erase command again after reset is completed.

Upon completion of automatic erase, the device returns to read mode.

The automatic erase operation status can be determined with the hardware sequence flags (I/O₇, I/O₆, RY/ $\overline{\text{BY}}$ pins). See sections "I/O₇ (Data Polling)", "I/O₆ (Toggle Bit)", and "RY/ $\overline{\text{BY}}$ (Ready / $\overline{\text{Busy}}$)".

For the timing waveform and flow chart, refer to Timing Waveform for Sector / Chip Erase and Figure 4.

Sector Erase Command Sequence

This command is used to erase data in sector units.

"0" is written to the entire sector whose data is to be erased by the automatic erase function after the command sequence has been written, and erase is executed after verification has been performed. Programming before erase and external control are not necessary.

The timeout period of sector erase starts when erase command 30H and the address of the sector to be erased are written at the sixth bus cycle. When this timeout period (50 μ s) has elapsed, the device automatically starts erasing.

Two or more sectors can be selected and erased at the same time by additionally writing erase command 30H and the address of the sector whose data is to be erased during the

timeout period. In this case, the timeout period starts again after the last erase command has been written.

If a protected sector and a sector that is not protected are included in the selected sectors, only the sector that is not protected is erased and the protected sector is ignored.

If a command other than the sector erase or erase suspend command is input during the timeout period, the device is reset to the read mode. If the timeout period has elapsed and erase has started, any command other than the erase suspend command is ignored. However, erase is stopped if hardware reset is executed. In this case, sector erase is not guaranteed. Execute the sector erase command again after completion of reset.

When automatic erasure has been completed, the device returns to the read mode.

Completion of automatic sector erase can be reported to the host system by using the data polling function of I/O₇, toggle bit function of I/O₆, and RY/ $\overline{\text{BY}}$ pin. Sector erase is started after the lapse of the timeout period that is started from the rising of the $\overline{\text{WE}}$ or $\overline{\text{CE}}$ pulse, whichever earlier, of the last sector erase command and is completed when the data of I/O₇ is set to "1" (refer to Hardware Sequence Flags). The device returns to the read mode. Data polling and toggle bit function in any address of the sector that is to be erased. The time required to erase two or more sectors is "(sector programming time + sector erase time) x number of sectors". If two or more sectors of different banks are erased, a read operation from a bank (i.e., dual operation) cannot be executed.

For the timing waveform and flow chart, refer to Timing Waveform for Sector / Chip Erase and Figure 4.

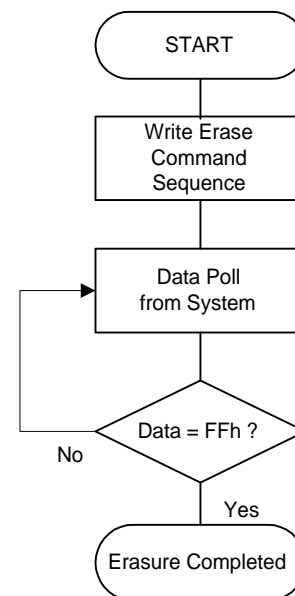

Figure 4. Sector / Chip Erase Flow Chart

Sector Erase Suspend / Resume Commands

This command suspends automatic erase. During erase suspend, sectors for which erase is not performed can be read and programmed.

Sector erase (including the timeout period) and data program operations can be both be suspended. Chip erase operations cannot be suspended. Suspend can be performed for all sectors for which erase is being performed.

Following command sequence write, 20µs are required until automatic erase is suspended.

While automatic erase is suspended, any sector for which erase is not being performed can be read and programmed.

Whether automatic erase is suspended can be determined with the hardware sequencing flags (I/O7, I/O6, I/O2 pins). See sections "I/O7 (Data Polling)", "I/O6 (Toggle Bit)", and "I/O2 (Toggle Bit II)".

If resume automatic erase that has been suspended, write the resume command (30H) while sector erase is suspended. At this time, input a bank address of the sector for which erasure is suspended.

Caution Sector Erase Suspend / Resume Commands

If automatic erase resume and suspend are repeated at intervals of less than 100µs, the erasure operation may not be correctly completed.

Unlock Bypass Command Sequence

This device provides an unlock bypass mode to shorten the program time.

Normally, 4 write cycle included with 2 unlock cycles are required during program. In contrast, with the unlock bypass mode, it is possible to perform program without unlock cycles.

In the unlock bypass mode, all commands except unlock bypass program and unlock bypass reset are ignored.

To end the unlock bypass mode, the unlock bypass reset command must be written. Note, however, that the unlock bypass reset command must be written to an address of the bank that is not being read in dual operation. If the unlock bypass reset command is written, the device returns to the normal read mode.

In the unlock bypass mode, the operating current is necessary even if $CE = V_{IH}$.

For the flowchart, refer to Figure 5.

Unlock Bypass Set

This command sets the device to the unlock bypass mode.

Unlock Bypass Program

This command is used to perform program in the unlock bypass mode.

Unlock Bypass Reset

This command is used to quit the unlock bypass mode.

When this command is executed, the device returns to the read mode.

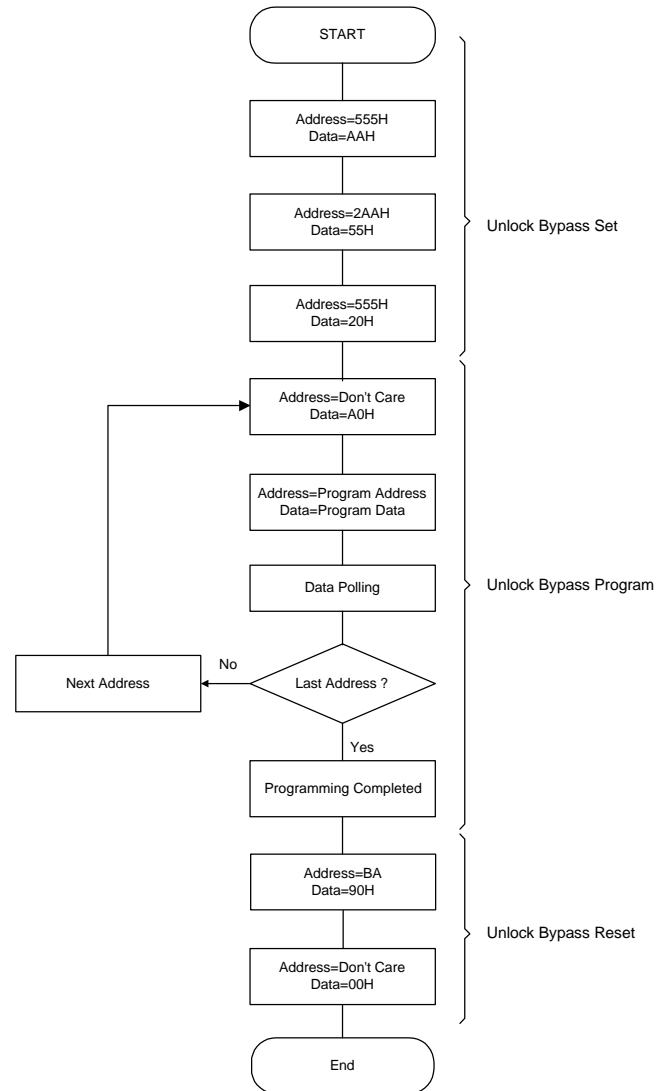

Note: This flow chart shows the WORD mode's case. In the BYTE mode, address to be input is different from the WORD mode. See Table 8. Command Sequence

Figure 5. Unlock Bypass Flow Chart (WORD Mode)

Table 8. A29DL323 Command Sequence

Command Sequence	Bus Cycle	1 st Bus Cycle		2 nd Bus Cycle		3 rd Bus Cycle		4 th Bus Cycle		5 th Bus Cycle		6 th Bus Cycle		
		Address	Data	Address	Data	Address	Data	Address	Data	Address	Data	Address	Data	
Read / Reset ^{Note 1}	1	XXXH	F0H	RA	RD	-	-	-	-	-	-	-	-	
Read / Reset ^{Note 1}	BYTE mode	3	AAAH	AAH	555H	55H	AAAH	F0H	RA	RD	-	-	-	
	WORD mode		555H		2AAH		555H							
Program	BYTE mode	4	AAAH	AAH	555H	55H	AAAH	A0H	PA	PD	-	-	-	
	WORD mode		555H		2AAH		555H							
Program Suspend ^{Note2}	1	BA	B0H	-	-	-	-	-	-	-	-	-	-	
Program Suspend ^{Note3}	1	BA	30H	-	-	-	-	-	-	-	-	-	-	
Chip Erase	BYTE mode	6	AAAH	AAH	555H	55H	AAAH	80H	AAAH	AAH	555H	55H	AAAH	10H
	WORD mode		555H		2AAH		555H		555H		2AAH		555H	
Sector Erase	BYTE mode	6	AAAH	AAH	555H	55H	AAAH	80H	AAAH	AAH	555H	55H	FSA	30H
	WORD mode		555H		2AAH		555H		555H		2AAH			
Sector Erase Suspend ^{Note4}	1	BA	B0H	-	-	-	-	-	-	-	-	-	-	
Sector Erase Suspend Resume ^{Note5}	1	BA	30H	-	-	-	-	-	-	-	-	-	-	
Unlock Bypass Set	BYTE mode	3	AAAH	AAH	555H	55H	AAAH	20H	-	-	-	-	-	
	WORD mode		555H		2AAH		555H							
Unlock Bypass Program ^{Note6}	2	XXXH	A0H	PA	PD	-	-	-	-	-	-	-	-	
Unlock Bypass Reset ^{Note7}	2	BA	90H	XXXH	00H ^{Note11}	-	-	-	-	-	-	-	-	
Product ID	BYTE mode	3	AAAH	AAH	555H	55H	(BA) AAAH	90H	IA	ID	-	-	-	
	WORD mode		555H		2AAH		(BA) 555H							
Sector Group Protection ^{Note7}	4	XXXH	60H	SPA	60H	SPA	40H	SPA	SD	-	-	-	-	
Sector Group Unprotect ^{Note8}	4	XXXH	60H	SUA	60H	SUA	40H	SUA	SD	-	-	-	-	
Query ^{Note9}	BYTE mode	1	AAH	98H	-	-	-	-	-	-	-	-	-	
	WORD mode		55H											
Extra One Time Protect Sector Entry	BYTE mode	3	AAAH	AAH	555H	55H	AAAH	88H	-	-	-	-	-	
	WORD mode		555H		2AAH		555H							
Extra One Time Protect Sector Program ^{Note10}	BYTE mode	4	AAAH	AAH	555H	55H	AAAH	A0H	PA	PD	-	-	-	
	WORD mode		555H		2AAH		555H							
Extra One Time Protect Sector Erase ^{Note10}	BYTE mode	6	AAAH	AAH	555H	55H	AAAH	80H	AAAH	AAH	555H	55H	EOTPSA	30H
	WORD mode		555H		2AAH		555H		555H		2AAH			
Extra One Time Protect Sector Reset ^{Note10}	BYTE mode	4	AAAH	AAH	555H	55H	AAAH	90H	XXXH	00H	-	-	-	
	WORD mode		555H		2AAH		555H							
Extra One Time Protect Sector Protection ^{Note10}	4	XXXH	60H	EOTPSA	60H	EOTPSA	40H	EOTPSA	SD	-	-	-	-	

Note:

- Both these read / reset commands reset the device to the read mode.
- Programming is suspended if B0H is input to the bank address being programmed to in a program operation.
- Programming is resumed if 30H is input to the bank address being suspended to in a program-suspend operation.
- Erasure is suspended if B0H is input to the bank address being erased in a sector erase operation.
- Erasure is resumed if 30H is input to the bank address being suspended in a sector-erase-suspend operation.
- Valid only in the unlock bypass mode.
- Valid only when RESET = V_{DD} (except in the Extra One Time Protect Sector mode).
- The command sequence that protects a sector group is excluded.

9. Only A0 to A6 are valid as an address.
10. Valid only in the Extra One Time Protect Sector mode.
11. This command can be used even if this data is F0H.

Remarks:

1. Specify address 555H or 2AAH (A10 to A0) in the WORD mode, and AAAH or 555H (A10 to A0, A-1) in the BYTE mode.
2. RA : Read address
RD : Read data
IA : Address input
 xx00H (to read the manufacturer code)
 xx02H (to read the device code in the BYTE mode)
 xx01H (to read the device code in the WORD mode)
ID : Code output. Refer to the Product ID code (Manufacturer code / Device code).
PA : Program address
PD : Program data
FSA: Erase sector address. The sector to be erased is selected by the combination of this address.
 Refer to the Sector Organization / Sector Address Table.
BA : Bank address. Refer to the Sector Organization / Sector Address Table.
SPA : Sector group address to be protected. Set sector group address (SGA) and (A6, A1, A0) = (V_{IL}, V_{IH}, V_{IL}).
SUA : Unprotect sector group address. Set sector group address (SGA) and (A6, A1, A0) = (V_{IH}, V_{IH}, V_{IL}).
EOTPSA : Extra One Time Protect Sector area addresses. These addresses are 3F0000H to 3FFFFFFH (BYTE mode) /
 1F8000H to 1FFFFFFH (WORD mode) for top boot, and 000000H to 00FFFFFFH (BYTE mode) / 000000H to
 007FFFH (WORD mode) for bottom boot.
SD : Data for verifying whether sector groups read from the address specified by SPA, SUA, and EOTPSA are protected or
 unprotected.
3. The sector group address is don't care except when a program / erase address or read address are selected.
4. × of address bit indicates V_{IH} or V_{IL}.

Hardware Sequence Flags

The status of automatic program / erase operations can be determined from the status of the I/O₂, I/O₃, I/O₅, I/O₆, I/O₇, and RY / \overline{BY} pins.

Caution When Reading Flags

When checking the completion or suspension status of an automatic program / erase operation by reading different sector data within the same bank, be sure to either clock the \overline{CE} or change the address before reading the data.

If the \overline{CE} is fixed to V_{IL} or data is read from the same address without the address being changed, the output data may not be output correctly.

I/O₇ : Data Polling

Data polling is a function to determine the status of automatic program / erase is currently being performed by using I/O₇.

Data polling is valid from the rise of the last \overline{WE} in the program / erase command sequence.

The status of automatic program is currently being executed can be determined by reading from the program destination addresses. While automatic programming is being executed or while automatic programming is being executed during erasure suspension, the complement of the final data programmed will be output to I/O₇. Upon completion of automatic program, the true value of the programmed data, not the complement, is output.

The status of automatic erase is in progress can be determined by reading from the addresses of the sector being erased. If erase is in progress, "0" is output to I/O₇. If the automatic erase operation is complete or if it is suspend, "1" will be output to I/O₇ when a sector for which erasure is suspended is read.

During automatic erase, if all the selected sectors are protected, data polling is valid for approximately 400 μ s. The device is then reset to the read mode. If the selected sectors include protected and unprotected sectors, only unprotected sectors are erased, and protected sectors are ignored.

Upon completion of automatic program / erase, after the data output to I/O₇ changes from the complement to the true value, I/O₇ changes asynchronously like I/O₀ to I/O₆ while \overline{OE} is maintained at low level.

For the timing waveform and flow chart, refer to Timing Waveform for Data Polling and Figure 6.

I/O₆ : Toggle Bit

The toggle bit is a function that uses I/O₆ to determine the status of automatic program / erase is in progress.

The toggle bit is valid from the rise of the last \overline{WE} in the program / erase command sequence.

If a continuous read is performed from any address of a bank that is undergoing automatic program or erase, I/O₆ will be toggled. If a sector other than the erased sector is

read after automatic program / erase is complete or when it is suspended, the I/O₆ toggle operation is stopped, and valid data for the read is output. If a sector for which erasure is suspended is read, "1" will be output to I/O₆. Continuous read control is performed with the \overline{OE} or \overline{CE} .

If program is performed for an address inside a protected sector, I/O₆ is toggled approximately 1 μ s, and then the device is reset to the read mode.

Moreover, if all the sectors selected at the time of automatic erase are protected, I/O₆ is toggled approximately 400 μ s, and then the device is reset to the read mode.

In this way, by using I/O₆, it is possible to determine the status of automatic erase is in progress (or suspended), but to determine which sector is being erased, I/O₂ (Toggle Bit II) is used. See section "I/O₂ (Toggle Bit II)".

For the timing waveform and flow chart, refer to Timing Waveform for Toggle Bit, Timing Waveform for I/O₂ vs. I/O₆ and Figure 7.

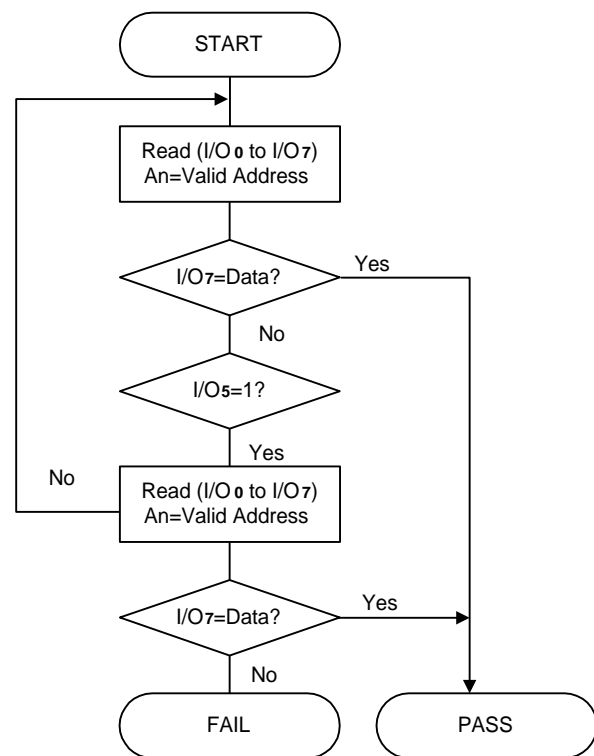

Figure 6. Data Polling Flow Chart

I/O₂: Toggle Bit II

Toggle bit II is a function that determines the status of automatic erase (or erase suspend) is in progress for a particular sector by using I/O₂.

I/O₂ is toggled when continuous read is performed from addresses in a sector during automatic erase (or erase suspend). Either \overline{OE} or \overline{CE} is used to control continuous read.

When program to a sector that is not subject to erase suspend is attempted during erase suspend, read from sectors that are not subject to erase suspend cannot be performed until program is completed. In this case, "1" will be output to I/O₂ if a continuous read is performed from an address in a sector other than an erased sector.

In this way, it is possible to determine the status of automatic erase (including erase suspend) is in progress for sectors specified using I/O₂, but whether the state is erase in progress or erase suspend cannot be determined with I/O₂. To determine this, I/O₆ (Toggle Bit) must be used. See section "I/O₆ (Toggle Bit)".

For the timing waveform, refer to Timing Waveform for I/O₂ vs. I/O₆.

I/O₅ : Exceeding Timing Limits

If the program / erase time exceeds the prescribed number of pulses during automatic program / erase (exceeding timing limit), "1" is output to I/O₅ and automatic program / erase failure is indicated.

Moreover, if overwriting "0" to "1" is attempted, the device judges data overwrite to be impossible, and "1" is output to I/O₅ when the timing limit is exceeded.

When this happens, execute command reset.

I/O₃ : Sector Erase Timer

A 50 μ s timeout period occurs following write with the sector erase command sequence before automatic erase starts.

During this timeout period, "0" is output to I/O₃. When automatic erase starts upon completion of the timeout period, "1" is output to I/O₃.

If sector erase is performed, first confirm whether the device has received a command by using I/O₇ (Data Polling) or I/O₆ (Toggle Bit). Then, using I/O₃, check whether automatic erase has started. If I/O₃ is "0", the timeout period is not over, and so it is possible to add sectors to erase. If I/O₃ is "1", automatic erase starts and other commands (except erase suspend) are ignored until erase is completed.

If a sector to erase is added during the sector erase timeout period, it is recommended to check I/O₃ prior to and following the addition. If I/O₃ is "1" following the addition, that addition may not be accepted.

$\overline{RY}/\overline{BY}$: Read/Busy

The $\overline{RY}/\overline{BY}$ is a dedicated output pin used to check the status of automatic program / erase is in progress.

During automatic program / erase, "0" is output to the $\overline{RY}/\overline{BY}$. If "1" is output, this signifies that the device is either in the read mode (including erase suspend) or standby mode.

Since the $\overline{RY}/\overline{BY}$ is an open-drain output pin, it is possible to connect several $\overline{RY}/\overline{BY}$ in series by connecting a pull-up resistor to VCC.

For the timing waveform, refer to Timing Waveform for $\overline{RY}/\overline{BY}$ (Ready / Busy).

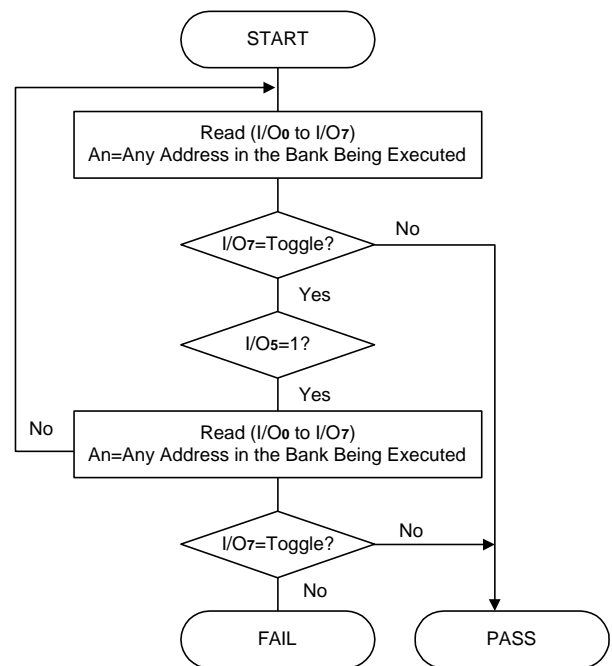

Figure 7. Toggle Bit Flow Chart

Table 9. Hardware Sequence Flags

Status		I/O ₇ (Note 1)	I/O ₆ (Note 2)	I/O ₅ (Note 3)	I/O ₃	I/O ₂ (Note 1)	RY/ $\overline{\text{BY}}$	
Progress	Program	$\overline{\text{I/O}}_7$	Toggle	0	0	1	0	
	Erase	0	Toggle	0	1	Toggle	0	
	Program Suspend	Program Sector	Data	Data	Data	Data	Data	Data
		Other than Program Sector	Data	Data	Data	Data	Data	1
	Erase Suspend	Erase Suspend Sector	1	1	0	0	Toggle	1
		Other than Erase Suspend Sector	Data	Data	Data	Data	Data	1
Erase Suspend Program		$\overline{\text{I/O}}_7$	Toggle	0	0	1	0	
Exceeding time limits	Program	0	Toggle	1	0	1	0	
	Erase	0	Toggle	1	1	N/A	0	
	Erase Suspend	$\overline{\text{I/O}}_7$	Toggle	1	0	N/A	0	

Notes:

1. To read I/O₇ or I/O₂, a valid address must be input.
2. To read I/O₆, any address can be used.
3. For I/O₅, "1" is output if the automatic program / erase time exceeds the prescribed number of internal pulses.



Electrical Characteristics

Before turning on power, input GND \pm 0.2 V to the $\overline{\text{RESET}}$ pin until VCC = VCC (MIN.).

DC Characteristics (Recommended Operating Conditions Unless Otherwise Noted)

Parameter			Symbol	Test Description	Min.	Typ.	Max.	Unit
High level input voltage			V _{IH}		2.4		VCC+0.3	V
Low level input voltage			V _{IL}		-0.3		+0.5	V
High level output voltage			V _{OH}	I _{OH} = -500 μ A, VCC = VCC (min.)	2.4			V
Low level output voltage			V _{OL}	I _{OL} = +1.0 mA, VCC = VCC (min.)			0.4	V
Input leakage current			I _{LI}		-1.0		+1.0	μ A
Output leakage current			I _{LO}		-1.0		+1.0	μ A
Power Supply Current	Read	BYTE mode	I _{CC1}	VCC = VCC (max.), $\overline{\text{CE}}$ = V _{IL} , $\overline{\text{OE}}$ = V _{IH}	t _{CYCLE} = 5 MHz	10	16	mA
					t _{CYCLE} = 1 MHz	2	4	
		WORD mode			t _{CYCLE} = 5 MHz	10	16	
					t _{CYCLE} = 1 MHz	2	4	
	Program, Erase		I _{CC2}	VCC = VCC (max.), $\overline{\text{CE}}$ = V _{IL} , $\overline{\text{OE}}$ = V _{IH}		15	30	mA
	Standby		I _{CC3}	VCC = VCC (max.), $\overline{\text{CE}}$ = $\overline{\text{RESET}}$ = $\overline{\text{WP}}$ (ACC) = VCC \pm 0.3 V, $\overline{\text{OE}}$ = V _{IL}		0.2	5	μ A
	Standby / Reset		I _{CC4}	VCC = VCC (max.), $\overline{\text{RESET}}$ = GND \pm 0.2 V		0.2	5	μ A
	Automatic sleep mode		I _{CC5}	V _{IH} = VCC \pm 0.2 V, V _{IL} = GND \pm 0.2 V		0.2	5	μ A
	Read during programming		I _{CC6}	V _{IH} = VCC \pm 0.2 V, V _{IL} = GND \pm 0.2 V		21	45	mA
	Read during erasing		I _{CC7}	V _{IH} = VCC \pm 0.2 V, V _{IL} = GND \pm 0.2 V		21	45	mA
	Programming during suspend		I _{CC8}	$\overline{\text{CE}}$ = V _{IL} , $\overline{\text{OE}}$ = V _{IH} , Automatic programming during suspend		17	35	mA
Accelerated programming		I _{ACC}	$\overline{\text{WP}}$ (ACC) pin		5	10	mA	
			VCC		15	30		
$\overline{\text{RESET}}$ high level input voltage			V _{ID}	High Voltage is applied	11.5		12.5	V
Accelerated programming voltage			V _{ACC}	High Voltage is applied	8.5		9.5	V
Low VCC lock-out voltage (Note)			V _{LKO}	V _{IH} = VCC \pm 0.3V; V _{IL} = VSS \pm 0.3V			1.7	V

Notes:

1. When VCC is equal to or lower than V_{LKO}, the device ignores all write cycles.

Remark: These DC characteristics are in common regardless of product classification.

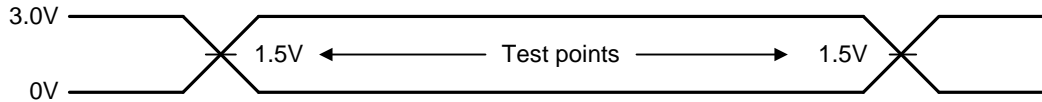
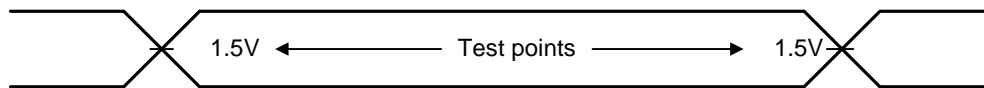
AC Characteristics (Recommended Operating Conditions Unless Otherwise Noted)
AC Test Conditions
Input Waveform (Rise and Fall Time = 5 ns)

Output Waveform

Output Load

1 TTL + 30pF

Read Cycle

Parameter	Symbol	Test Condition	Min.	Typ.	Max.	Unit	Notes
Read cycle time	t _{RC}		85			ns	
Address access time	t _{ACC}	$\overline{CE} = \overline{OE} = V_{IL}$			85	ns	
\overline{CE} access time	t _{CE}	$\overline{OE} = V_{IL}$			85	ns	
\overline{OE} access time	t _{OE}	$\overline{CE} = V_{IL}$			40	ns	
Output disable time	t _{DF}	$\overline{OE} = V_{IL}$ or $\overline{CE} = V_{IL}$			30	ns	
Output hold time	t _{OH}		0			ns	
\overline{RESET} pulse width	t _{RP}		500			ns	
\overline{RESET} hold time before read	t _{RH}		50			ns	
\overline{RESET} low to read mode	t _{READY}				20	μs	
\overline{CE} low to /BYTE low, high	t _{ELFL} /t _{ELFH}				5	ns	
\overline{BYTE} low output disable time	t _{FLQZ}				30	ns	
\overline{BYTE} high access time	t _{FHQV}		85			ns	

 Remark: t_{DF} is the time from inactivation of \overline{CE} or \overline{OE} to Hi-Z state output.

AC Characteristics
Write Cycle (Program / Erase)

Parameter	Symbol	Min.	Typ.	Max.	Unit	Notes
Write cycle time	t _{wc}	85			ns	
Address setup time (\overline{WE} to address)	t _{ac}	0			ns	
Address setup time (\overline{CE} to address)	t _{as}	0			ns	
Address hold time (\overline{WE} to address)	t _{ah}	45			ns	
Address hold time (\overline{CE} to address)	t _{ah}	45			ns	
Input data setup time	t _{ds}	35			ns	
Input data hold time	t _{dh}	0			ns	
OE hold time	Read	0			ns	
	Toggle bit, Data polling	10				
Read recovery time before write (\overline{OE} to \overline{CE})	t _{ghel}	0			ns	
Read recovery time before write (\overline{OE} to \overline{WE})	t _{ghwl}	0			ns	
\overline{WE} setup time (\overline{CE} to \overline{WE})	t _{ws}	0			ns	
\overline{CE} setup time (\overline{WE} to \overline{CE})	t _{cs}	0			ns	
\overline{WE} hold time (\overline{CE} to \overline{WE})	t _{wh}	0			ns	
\overline{CE} hold time (\overline{WE} to \overline{CE})	t _{ch}	0			ns	
Write pulse width	t _{wp}	35			ns	
\overline{CE} pulse width	t _{cp}	35			ns	
Write pulse width high	t _{wph}	30			ns	
\overline{CE} pulse width high	t _{cpH}	30			ns	
Byte programming operation time	t _{bpg}		9	200	μs	
Word programming operation time	t _{wpg}		11	200	μs	
Sector erase operation time	t _{ser}		0.7	5	s	1
VCC set time	t _{vcs}	50			μs	
RY/BY recovery time	t _{rb}	0			ns	
RESET pulse width	t _{rp}	500			ns	
RESET high-voltage (V _{IB}) hold time from high of RY/BY when sector group is temporarily unprotect	t _{rrb}	20			μs	
RESET hold time	t _{rh}	50			ns	
From completion of automatic program / erase to data output time	t _{oe}			85	ns	
RY/BY delay time from valid program or erase operation	t _{busy}			90	ns	
Address setup time to OE low in toggle bit	t _{aso}	15			ns	
Address hold time to \overline{CE} or OE high in toggle bit	t _{aht}	0			ns	

Write Cycle (Program / Erase) (continued)

Parameter	Symbol	Min.	Typ.	Max.	Unit	Notes
\overline{CE} pulse width high for toggle bit	tCEPH	20			ns	
\overline{OE} pulse width high for toggle bit	tOEPH	20			ns	
Voltage transition time	tVLHT	4			μ s	2
Rise time to V_{ID} (\overline{RESET})	tVIDR	500			ns	3
Rise time to V_{Acc} (\overline{WE} (ACC))	tVACCR	500			ns	2
Erase timeout time	tTOW	50			μ s	4
Erase suspend transition time	tSPD			20	μ s	4

Notes:

1. The preprogramming time prior to the erase operation is not included.
2. Sector group protection and accelerated mode only.
3. Sector group protection only.
4. Table only.

Write operation (Erase / Program) Performance

Parameter	Description	Min.	Typ.	Max.	Unit
Sector erase time	Excludes programming time prior to erasure		0.7	5	s
Chip erase time	Excludes programming time prior to erasure		50		s
Byte programming time	Excludes system-level overhead		9	200	μ s
Word programming time	Excludes system-level overhead		11	200	μ s
Chip programming time	Excludes system-level overhead	BYTE mode	40		s
		WORD mode	25		
Accelerated programming time	Excludes system-level overhead		7	150	μ s
Erase / Program cycle		1,000,000			cycle

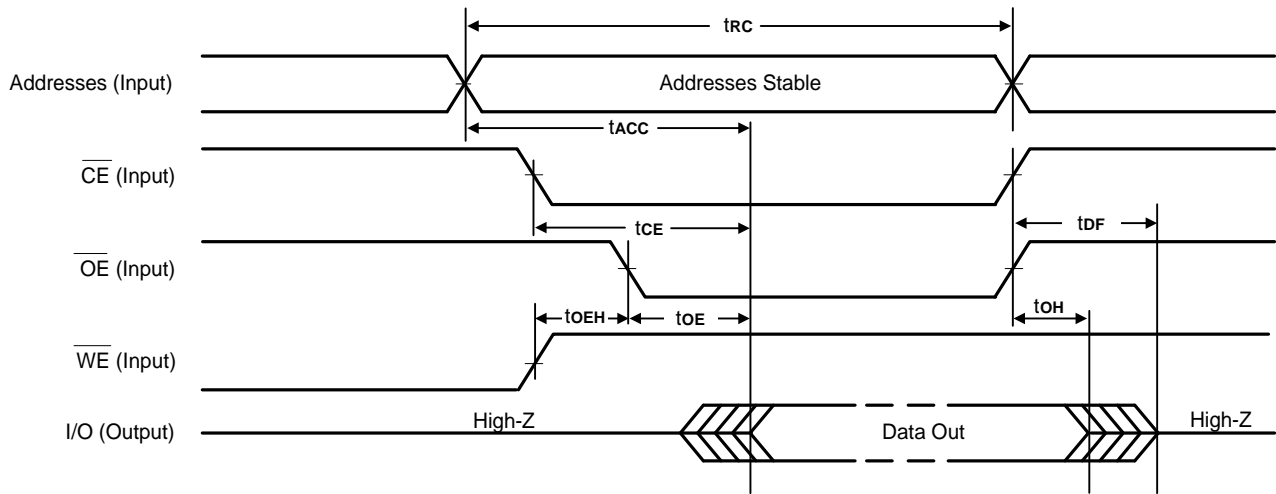
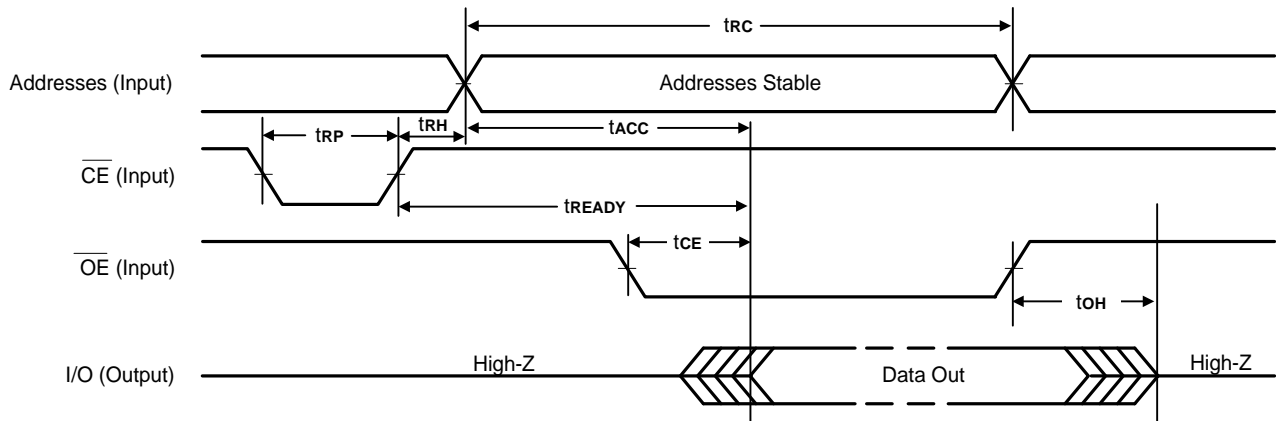
Timing Waveform for Read Cycle (1)

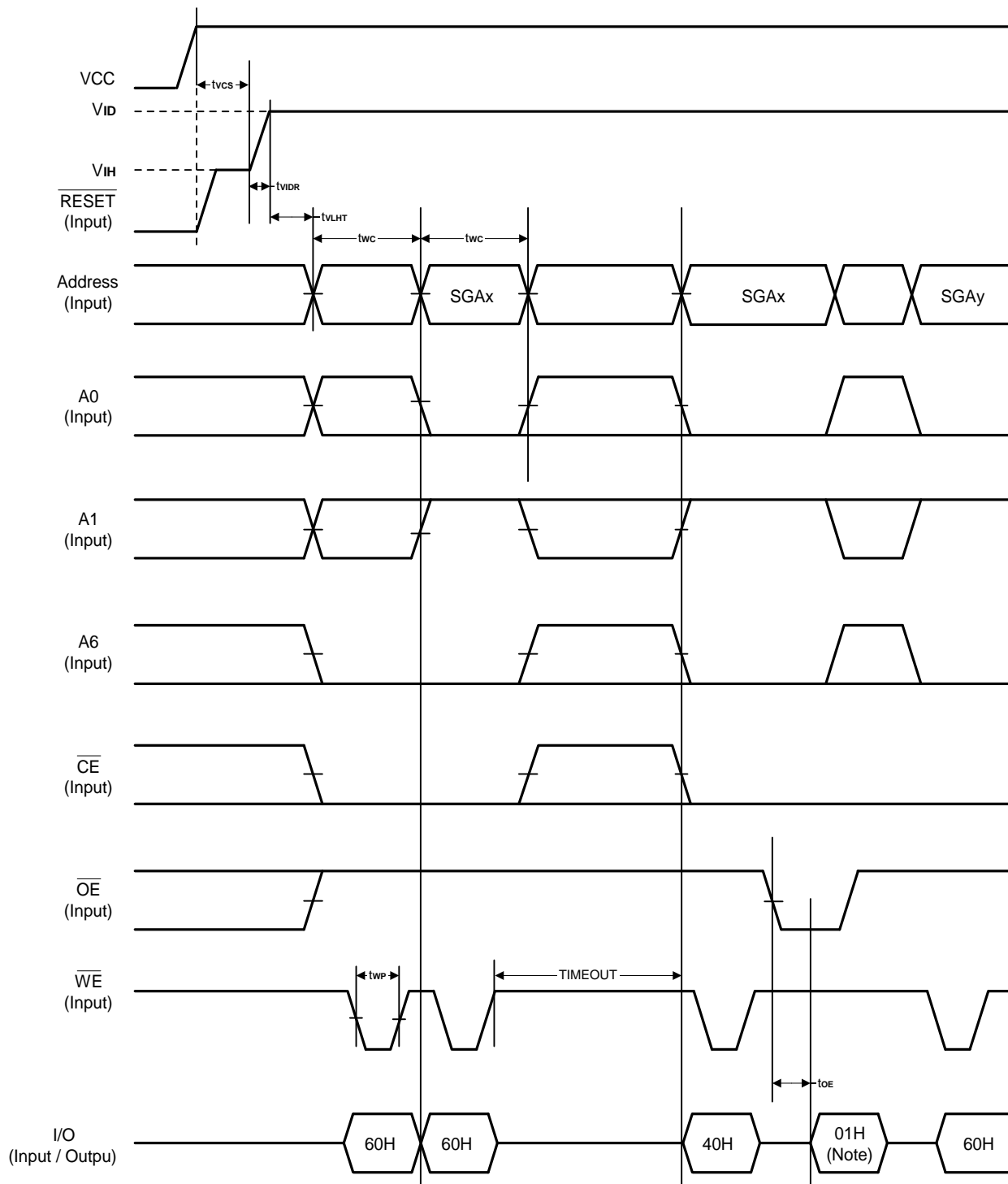
Timing Waveform for Read Cycle (2)

Timing Waveform for Sector Group Protection

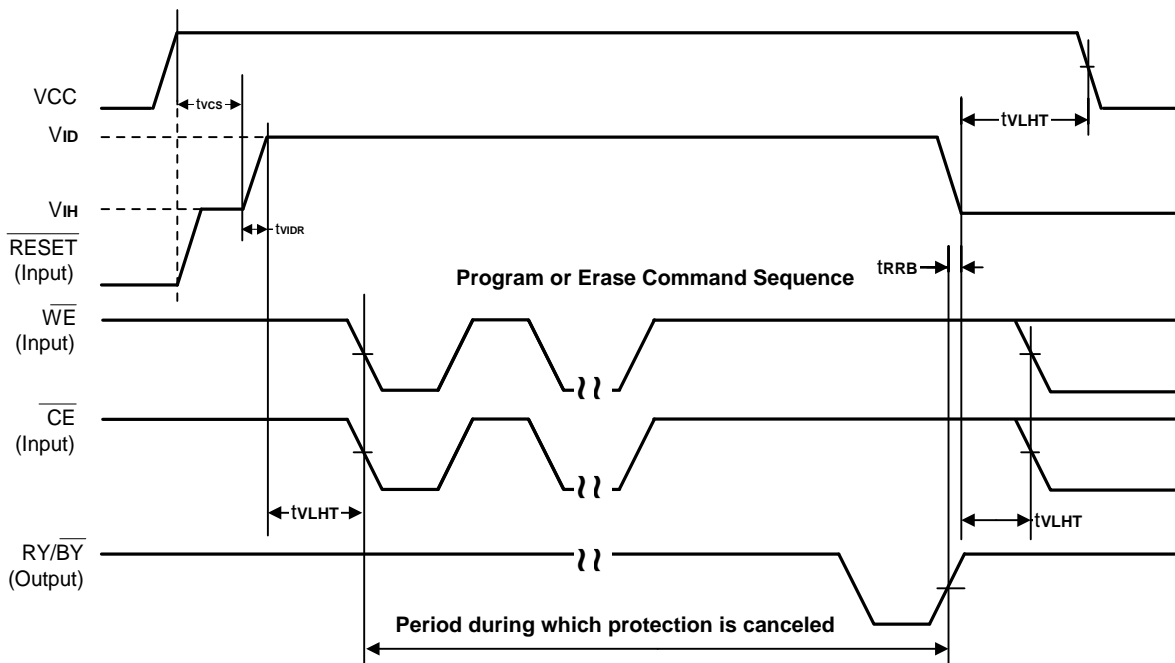
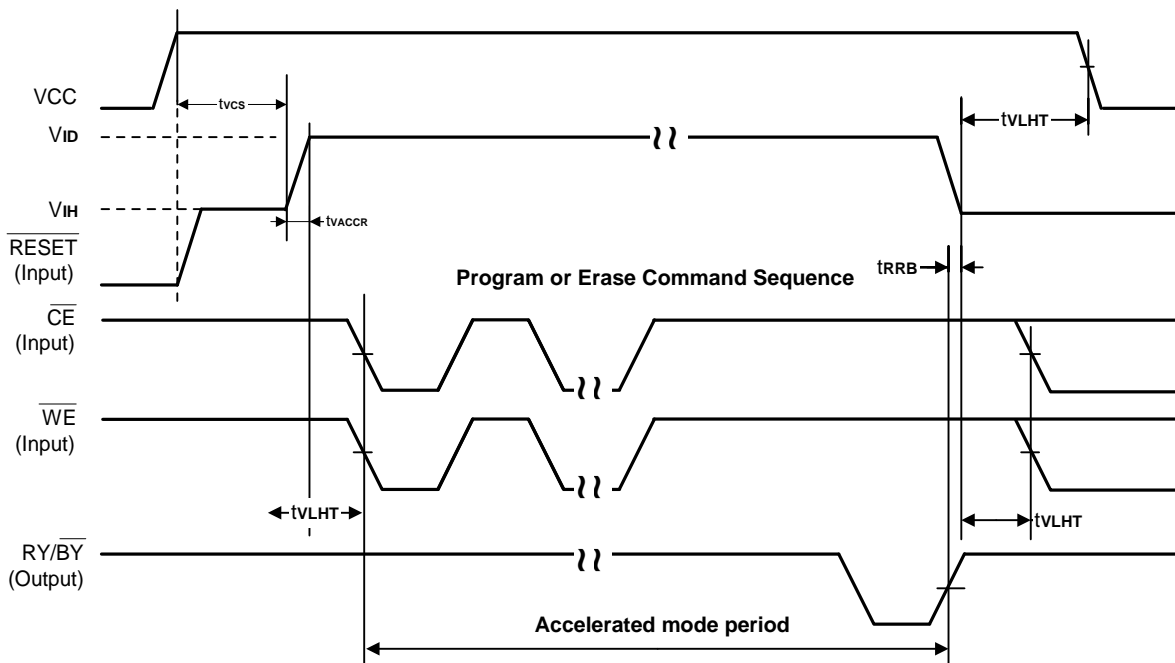
Note: The sector group protection verification result is output
 01H: The sector group is protected.
 00H: The sector group is not protected

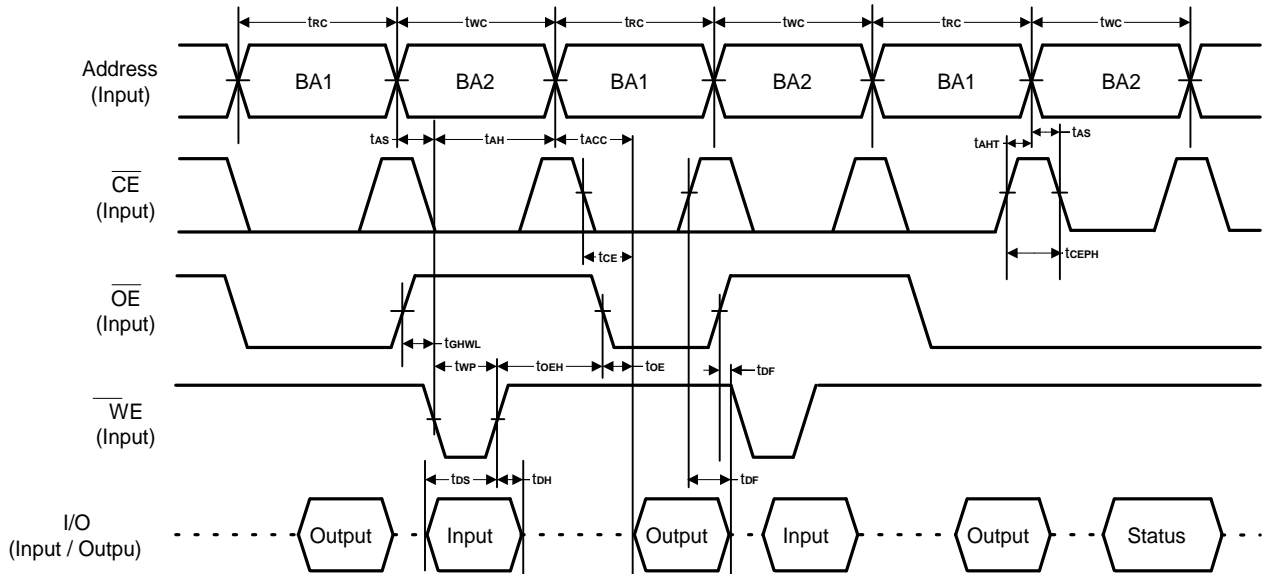
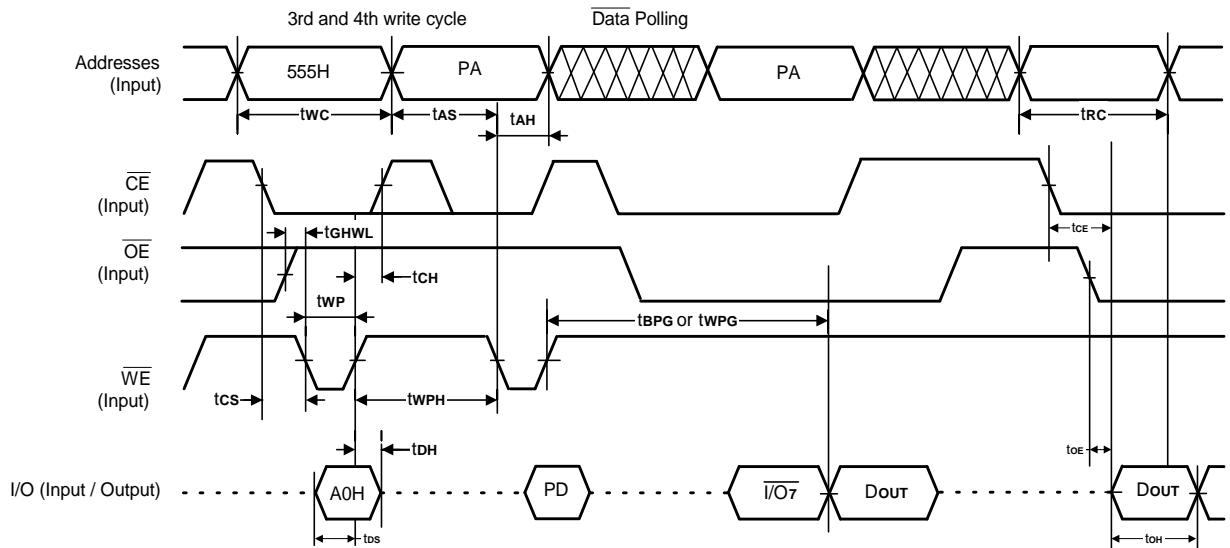
Timing Waveform for Temporary Sector Group Unprotect

Timing Waveform for Accelerated Mode

Timing Waveform for Dual Operation

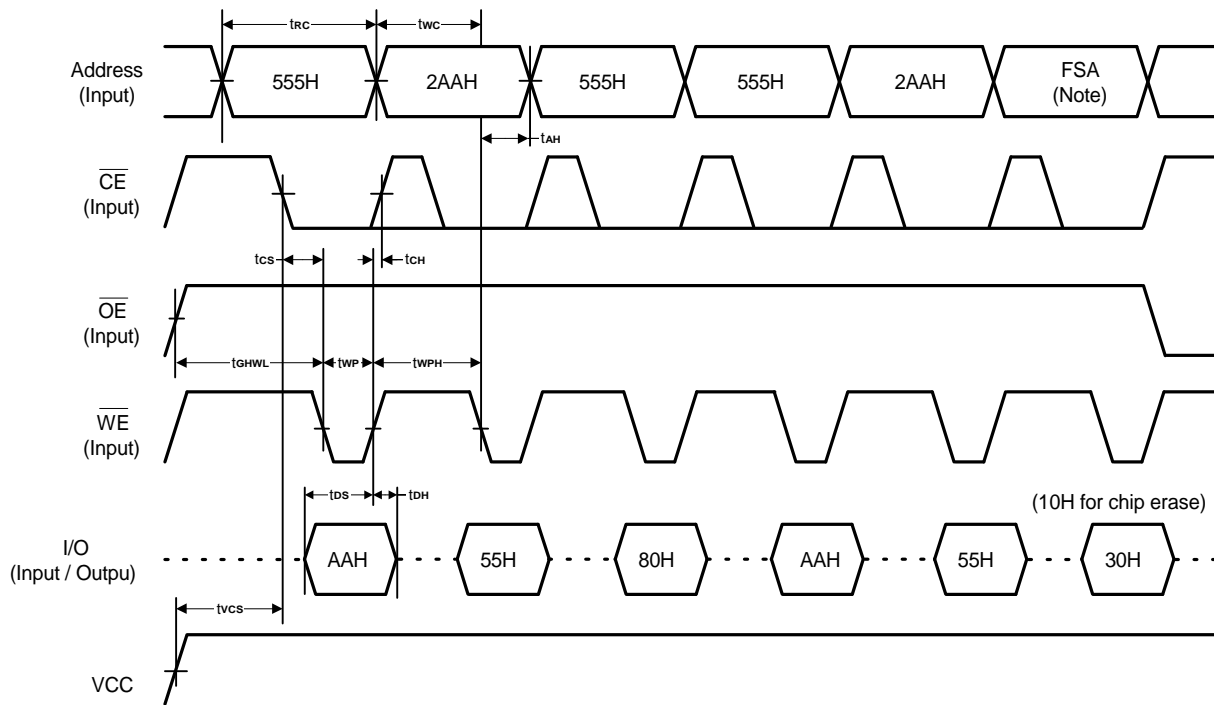
Timing Waveform for Write Cycle (\overline{WE} Controlled)

Note :

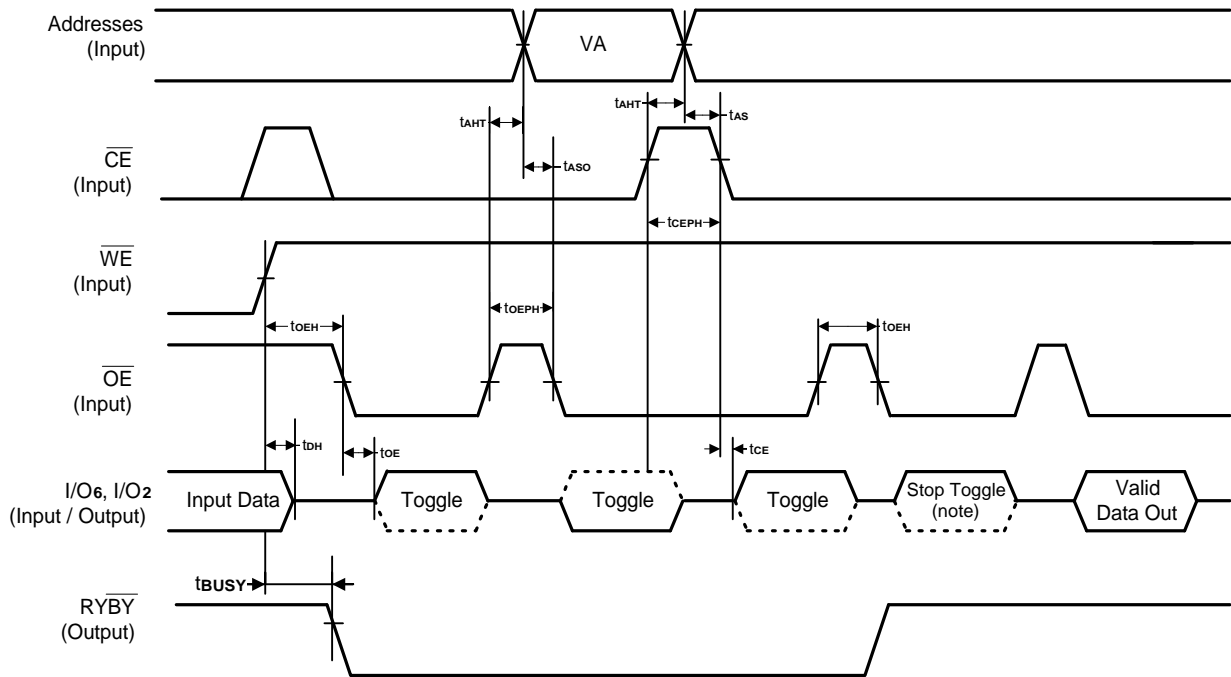
1. This timing waveform shows the last two write cycles among the program command sequence's four write cycles, and data polling.
2. This timing waveform shows the WORD mode's case. In the BYTE mode, address to be input is different from the WORD mode. See Table 8. Command Sequence.
3. PA : Program address
 PD : Program data
 $\overline{I/O_7}$: The output of the complement of the data written to the device.
 Dout : The output of the data written to the device.

Timing Waveform for Sector / Chip Erase

Note :

1. FSA is the sector address to be erased. In the case of chip erase, input 555H (WORD mode), AAAH (BYTE mode).
2. This timing chart shows the WORD mode's case. In the BYTE mode, address to be input is different from the WORD mode. See Table 8. Command Sequence.

Timing Waveform for Toggle Bit

Note :

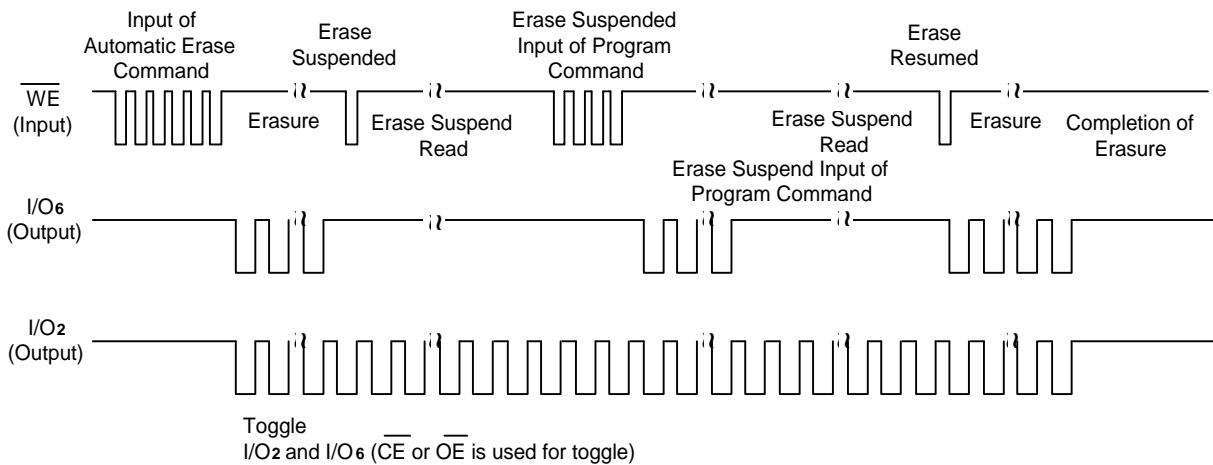
1. I/O₆ stops the toggle (indicates automatic program / erase completion).

Timing Waveforms for I/O₂ vs. I/O₆

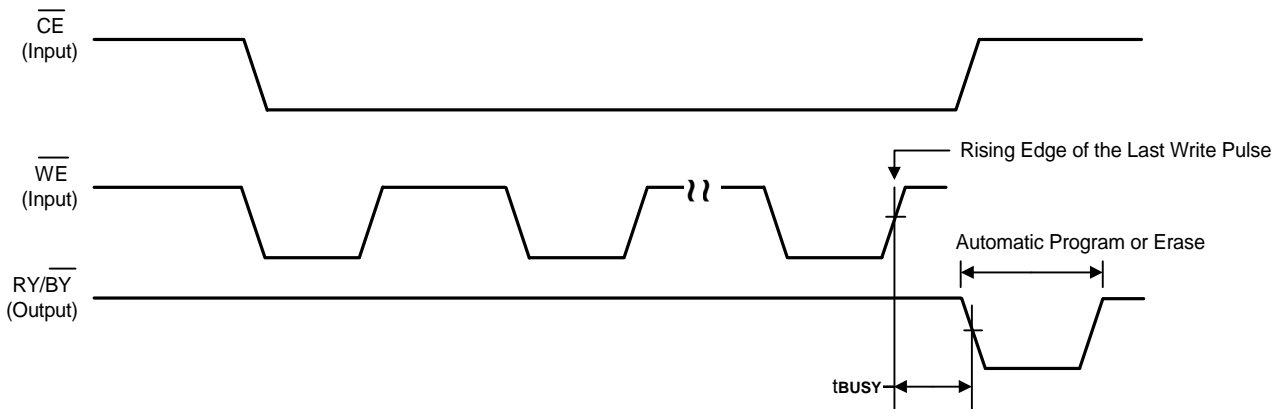
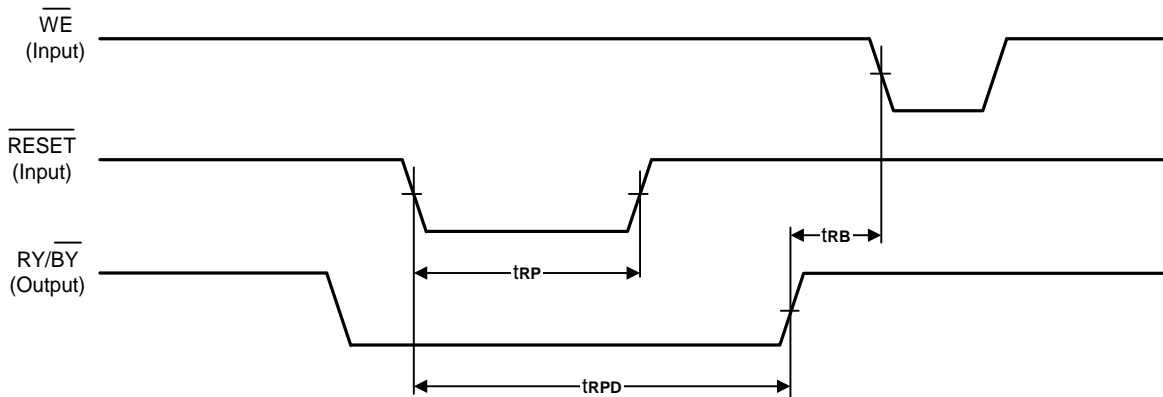
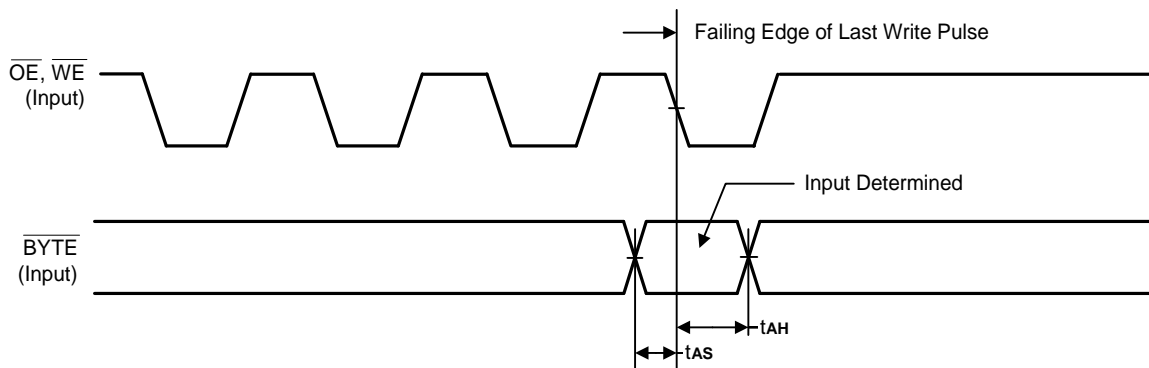
Timing Waveform for RY/ $\overline{\text{BY}}$ (Read / Busy)

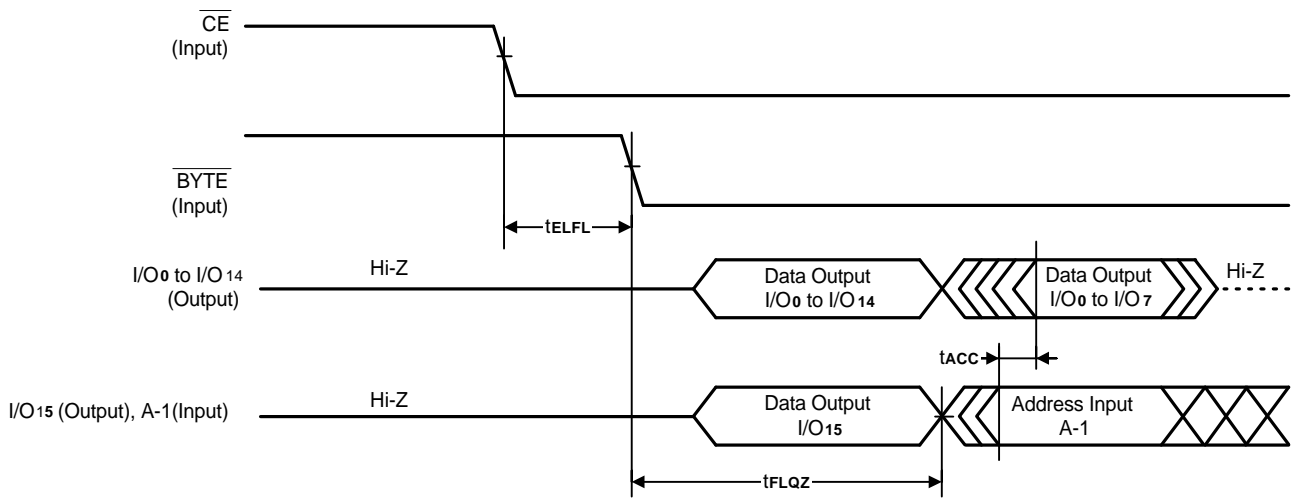
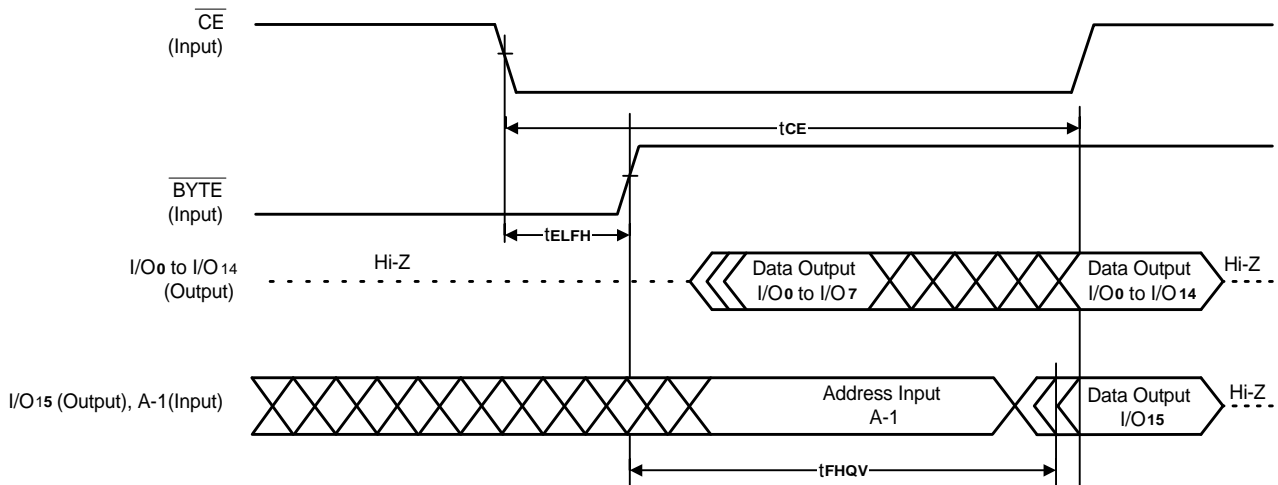
Timing Waveform for $\overline{\text{RESET}}$ / RY / BY

Timing Waveform for BYTE

Timing Waveform for BYTE Mode Switching

Timing Waveform for WORD Mode Switching

Latch-up Characteristics

Description	Min.	Max.
Input Voltage with respect to VSS on all I/O pins	-1.0V	VCC+1.0V
VCC Current	-100 mA	+100 mA
Input voltage with respect to VSS on all pins except I/O pins (including A9, \overline{OE} and RESET)	-1.0V	12.5V

Includes all pins except VCC. Test conditions: VCC = 5.0V, one pin at time.

Capacitance (TA = 25°C, f = 1MHz)

Parameter Symbol	Parameter Description	Test Setup	Typ.	Max.	Unit
C _{IN}	Input Capacitance	V _{IN} =0	6	7.5	pF
C _{OUT}	Output Capacitance	V _{OUT} =0	8.5	12	pF

Notes:

1. V_{IN}: Input voltage, V_{OUT}: Output voltage
2. These parameters are not 100% tested.

Data Retention

Parameter	Test Conditions	Min	Unit
Minimum Pattern Data Retention Time	150°C	10	Years
	125°C	20	Years



Ordering Information

Part No.	Access Time (ns)	Operating Supply Voltage (V)	Boot Sector	Package
A29DL323TV-90	90	2.7 to 3.6	Top Address (Sector) (T type)	48Pin TSOP
A29DL323UV-90			Bottom Address (Sector) (B type)	48Pin TSOP
A29DL323TG-90			Top Address (Sector) (T type)	63-ball TFBGA
A29DL323UG-90			Bottom Address (Sector) (B type)	63-ball TFBGA

Package Information
TSOP 48L (Type I) Outline Dimensions

unit: inches/mm

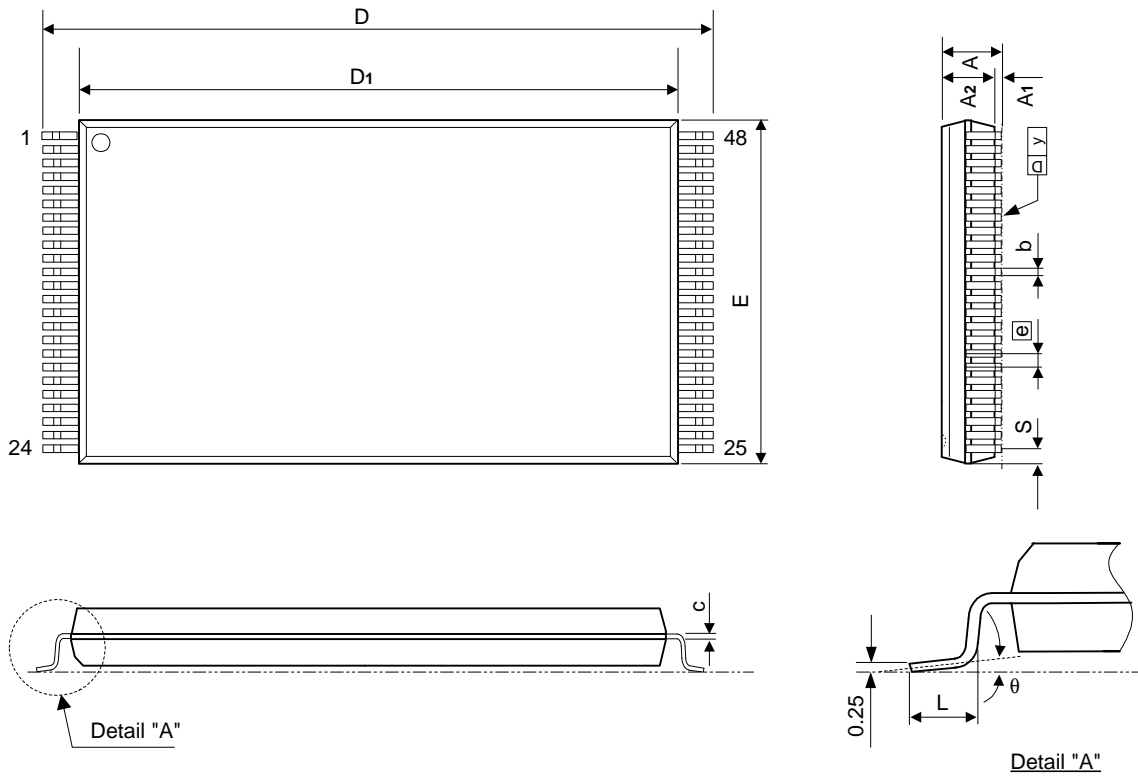

Symbol	Dimensions in inches			Dimensions in mm		
	Min	Nom	Max	Min	Nom	Max
A	-	-	0.047	-	-	1.20
A ₁	0.002	-	0.006	0.05	-	0.15
A ₂	0.037	0.039	0.042	0.94	1.00	1.06
b	0.007	0.009	0.011	0.18	0.22	0.27
c	0.004	-	0.008	0.12	-	0.20
D	0.779	0.787	0.795	19.80	20.00	20.20
D ₁	0.720	0.724	0.728	18.30	18.40	18.50
E	-	0.472	0.476	-	12.00	12.10
e	0.020 BASIC			0.50 BASIC		
L	0.016	0.020	0.024	0.40	0.50	0.60
S	0.011 Typ.			0.28 Typ.		
y	-	-	0.004	-	-	0.10
θ	0°	-	8°	0°	-	8°

Notes:

1. The maximum value of dimension D includes end flash.
2. Dimension E does not include resin fins.
3. Dimension S includes end flash.

Package Information
63 BALLS TFBGA (7 x 11mm) Outline Dimensions

unit: mm

