



Z86C60/65

CMOS Z8[®]

32KROM MICROCONTROLLER

FEATURES

Part	ROM (KB)	RAM* (Bytes)	I/O	Speed (MHz)	28-pin DIP
Z86C60	16	256	22	16	X
Z86C65	32	256	22	16	X

*General-Purpose

- 28-Pin DIP Package
- 3.0V to 5.5V Operating Range
- Low-Power Consumption: 200 mW
- Fast Instruction Pointer: 0.75 μ s @ 16 MHz
- Two Standby Modes: STOP and HALT
- Low EMI Mode Option
- Auto Latches
- Two Programmable 8-Bit Counter/Timers Each with 6-Bit Programmable Prescaler
- Three Vectored, Priority Interrupts from Three Different Sources
- On-Chip Oscillator that Accepts a Crystal Ceramic Resonator, LC, or External Clock Source
- ROM Mask Options:
 - ROM Protect
 - RAM Protect

GENERAL DESCRIPTION

The Z86C60/65 microcontrollers introduce a new level of sophistication to single-chip architecture. The Z86C65 is a member of the Z8 single-chip microcontroller family with 32 Kbytes of ROM and 256 bytes of RAM. The Z86C60 is identical, except that it only has 16 Kbytes of ROM.

The Z86C60/65 are housed in a 28-pin DIP package, and manufactured in CMOS technology. The Z86C96 ROMless Z8 will support the Z86C60/65.

Zilog's CMOS microcontroller offers fast execution, more efficient use of memory, more sophisticated interrupts, input/output bit manipulation capabilities, and easy hardware/software system expansion along with low cost and low power consumption.

The Z86C60/65 architecture is characterized by Zilog's 8-bit microcontroller core. The device offers a flexible I/O scheme, an efficient register and address space structure, multiplexed capabilities between address/data, I/O, and a number of ancillary features that are useful in many industrial and advanced scientific applications.

For applications which demand powerful I/O capabilities, the Z86C60/65 fulfills this with 22 pins dedicated to input

and output. These lines are grouped into four ports. Each port is configurable under software control to provide timing, status signals, serial or parallel I/O with or without handshake, and an address/data bus for interfacing external memory.

There are three basic address spaces available to support this wide range of configurations: Program Memory, Data Memory, and 236 General-Purpose Registers.

To unburden the program from coping with the real-time problems such as counting/timing and serial data communication, the Z86C60/65 offers two on-chip counter/timers with a large number of user selectable modes.

Notes:

All Signals with a preceding front slash, "/", are active Low, e.g., B/W (WORD is active Low); /B/W (BYTE is active Low, only).

Power connections follow conventional descriptions below:

Connection	Circuit	Device
Power Ground	V _{CC} GND	V _{DD} V _{SS}

GENERAL DESCRIPTION

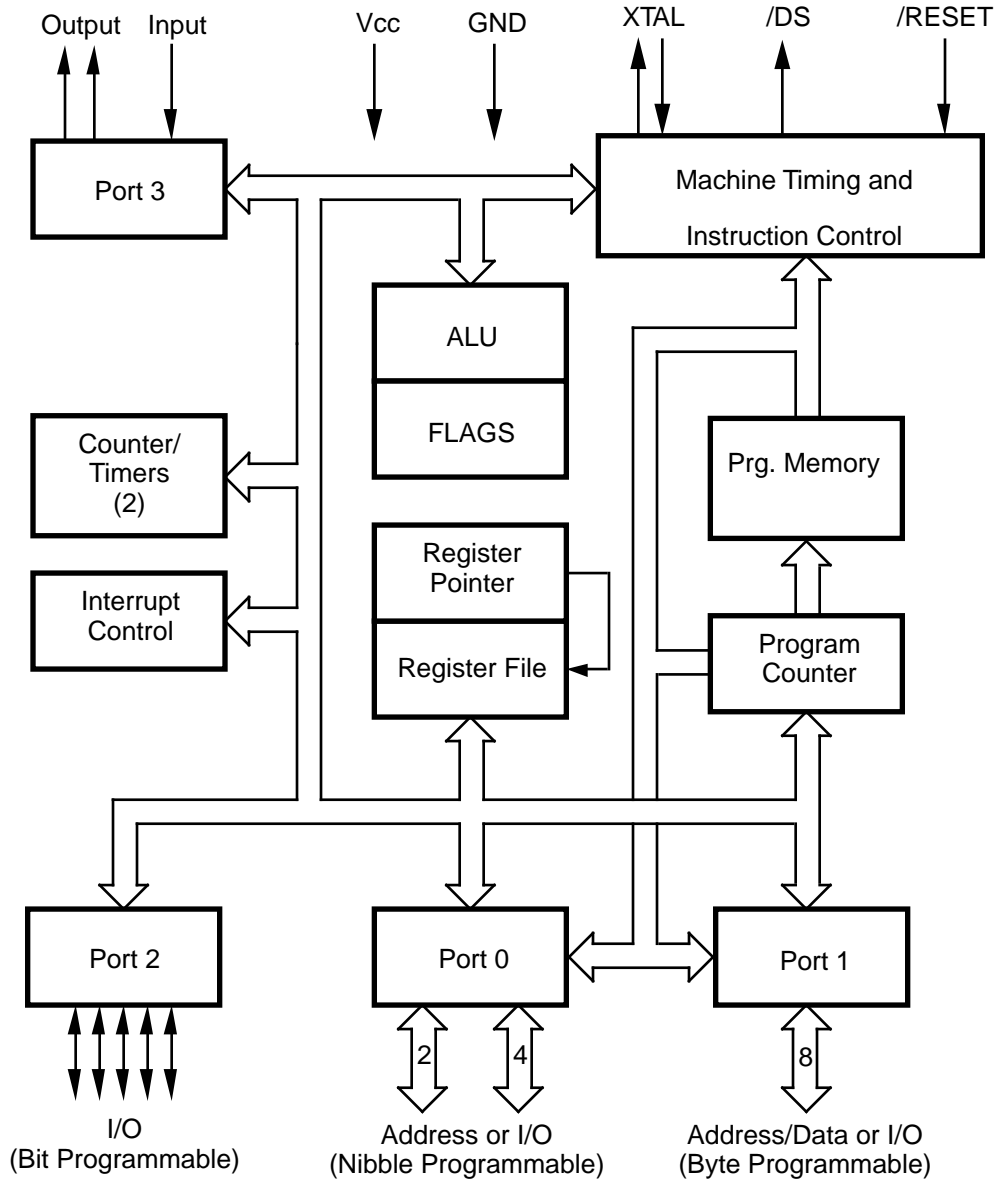
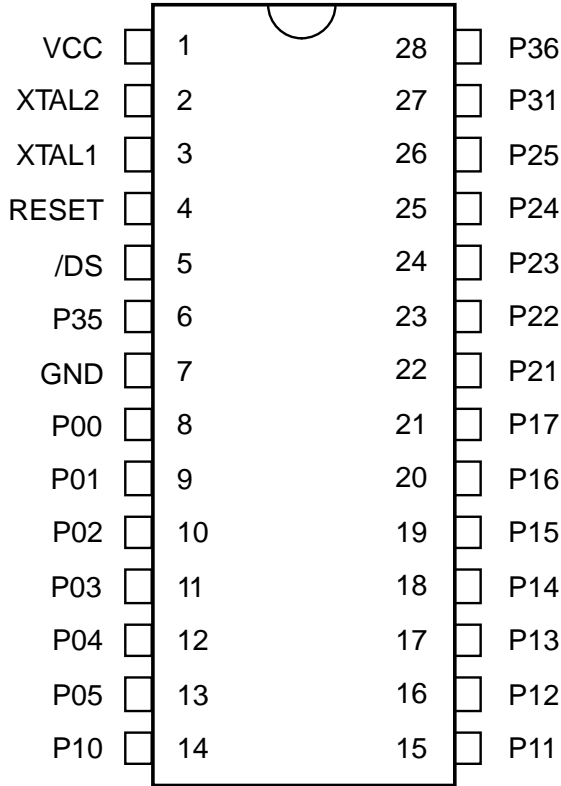

Figure 1. Z86C60/65 Functional Block Diagram

PIN DESCRIPTION



Z86C60/65 28-Pin DIP Pin Identification

Pin #	Symbol	Function	Direction
1	V _{CC}	Power Supply	Input
2	XTAL2	Crystal, Oscillator Clock	Output
3	XTAL1	Crystal, Oscillator Clock	Input
4	/RESET	Reset	Input
5	/DS	Data Strobe	Output
6	P35	Port 3, Pin 5	Output
7	GND	Ground	Input
8-13	P05-P00	Port 0, Pins 0,1,2,3,4,5	In/Output
14-21	P17-P10	Port 1, Pins 0,1,2,3,4,5,6,7	In/Output
22-26	P25-P21	Port 2, Pins 1,2,3,4,5	In/Output
27	P31	Port 3, Pin 1	Input
28	P36	Port 3, Pin 6	Output

Figure 2. Z86C60/65 28-Pin DIP Pin Assignments

ABSOLUTE MAXIMUM RATINGS

Symbol	Description	Min	Max	Units
V_{CC}	Supply Voltage*	-0.3	+7.0	V
T_{STG}	Storage Temp	-65	+150	C
T_A	Oper Ambient Temp	†	†	

Notes:

- * Voltages on all pins with respect to GND.
- † See ordering information

Stresses greater than those listed under Absolute Maximum Ratings may cause permanent damage to the device. This is a stress rating only; operation of the device at any condition above those indicated in the operational sections of these specifications is not implied. Exposure to absolute maximum rating conditions for an extended period may affect device reliability.

STANDARD TEST CONDITIONS

The characteristics listed below apply for standard test conditions as noted. All voltages are referenced to GND. Positive current flows into the referenced pin (Test Load).

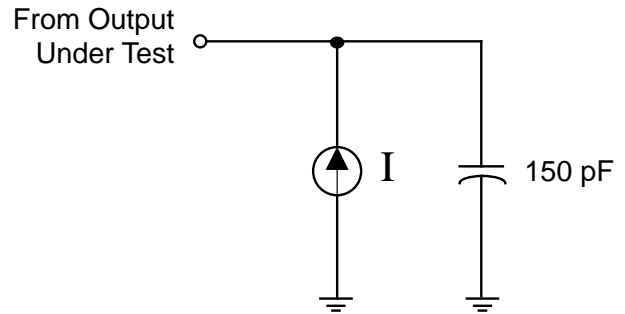

Figure 3. Test Load Diagram

DC ELECTRICAL CHARACTERISTICS

Z86C60/65

Sym	Parameter	$T_A = 0^\circ\text{C}$ to $+70^\circ\text{C}$		Typical at 25°C	Units	Conditions
		Min	Max			
V_{CC}	Operating Voltage	4.5	5.5		V	[3]
	Max Input Voltage		7		V	[3] $I_{IN} < 250\mu\text{A}$
V_{GH}	Clock Input High Voltage	$0.85V_{CC}$	$V_{CC} + 0.3$		V	Driven by External Clock Generator
V_{GL}	Clock Input Low Voltage	$V_{SS} - 0.3$	0.8		V	Driven by External Clock Generator
V_H	Input High Voltage	2	$V_{CC} + 0.3$		V	
V_L	Input Low Voltage	$V_{SS} - 0.3$	$0.2V_{CC}$		V	
V_{OH}	Output High Voltage	24	V_{CC}		V	$I_{OH} = -2.0\text{mA}$
V_{OH}	Output High Voltage		$V_{CC} - 100\text{mV}$		V	$I_{OH} = -100\mu\text{A}$
V_{OH}	Output High Voltage (Low EMI)	24			V	$I_{OH} = -0.5\text{mA}$
V_{OL}	Output Low Voltage		0.4		V	$I_{OL} = +5.0\text{mA}$ [2]
V_{OL}	Output Low Voltage (Low EMI)		0.4		V	$I_{OL} = +2.0\text{mA}$ [2]
V_{RH}	Reset Input High Voltage	$0.85V_{CC}$	$V_{CC} + 0.3$		V	
V_{RL}	Reset Input Low Voltage	-0.3	$0.2V_{CC}$		V	
I_{IL}	Input Leakage	-2	2		μA	$V_{IN} = 0\text{V}, V_{CC}$
I_{OL}	Output Leakage	-2	2		μA	$V_{IN} = 0\text{V}, V_{CC}$
I_R	Reset Input Current		-180		μA	$V_{RL} = 0\text{V}$
I_{CC}	Supply Current (Standard Mode)		35	24	nA	[1] @ 16MHz
I_{CC}	Supply Current (Low EMI)		60	40	nA	@ 4MHz
I_{CC1}	Standby Current (Standard Mode)		15	4.5	nA	[1] HALT Mode $V_{IN} = 0\text{V}, V_{CC}$ @ 16MHz
I_{CC1}	Standby Current (Low EMI)		1.6	0.8	nA	@ 4MHz
I_{CC2}	Standby Current		10	5	μA	[1] STOP Mode $V_{IN} = 0\text{V}, V_{CC}$
I_{ALL}	Auto Latch Low Current	-14	+14	5	μA	$V_{CC} = 5.0\text{V}$

Notes:

- [1] All inputs driven to either 0V or V_{CC} , outputs floating.
 [2] $V_{CC} = 4.5\text{V}$ to 5.5V
 [3] /Reset pin must be a maximum of $V_{CC} + 0.3\text{V}$.

AC CHARACTERISTICS

Additional Timing Diagram

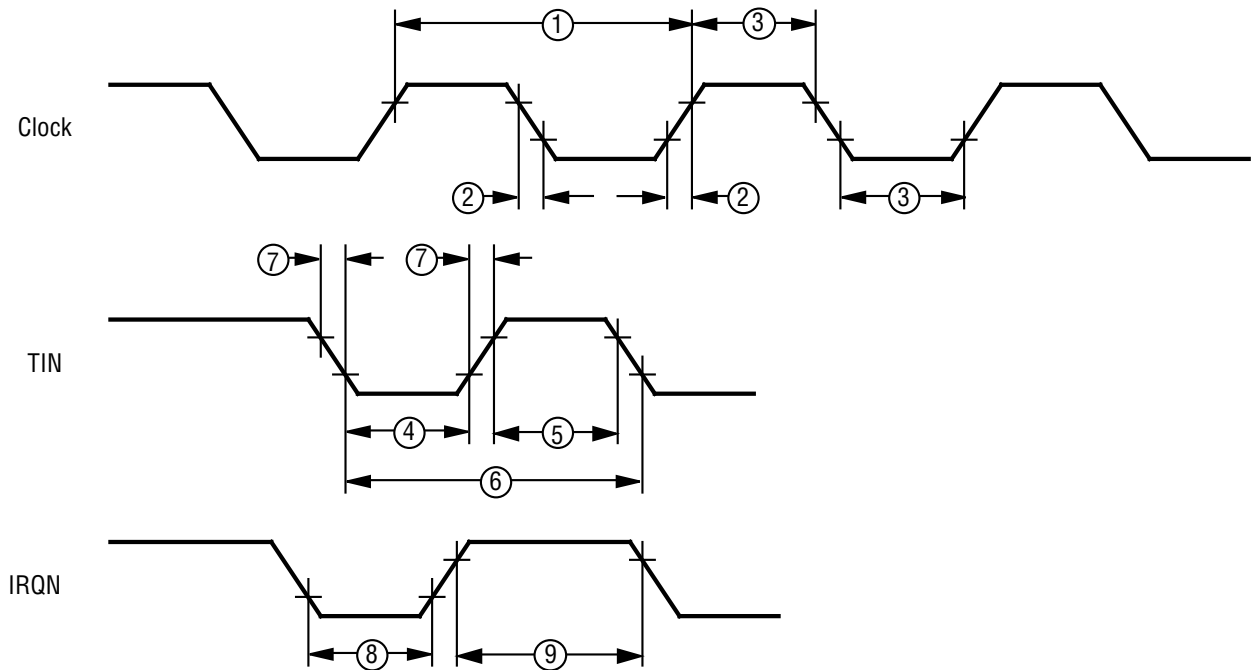

Figure 4. Additional Timing

AC CHARACTERISTICS

Additional Timing Table

Z86C60/65 (Standard Mode Only)

No	Symbol	Parameter	$T_A = 0^\circ\text{C}$ to $+70^\circ\text{C}$		Units	Notes
			Min	Max		
1	TpC	Input Clock Period	62.5	DC	ns	[1]
2	TrC,TfC	Clock Input Rise & Fall Times		10	ns	[1]
3	TwC	Input Clock Width	31		ns	[1]
4	TwTinL	Timer Input Low Width	75		ns	[2]
5	TwTinH	Timer Input High Width	5 TpC		ns	[2]
6	TpTin	Timer Input Period	8 TpC		ns	[2]
7	TrTin,TfTin	Timer Input Rise and Fall Times	100		ns	[2]
8a	TwIL	Interrupt Request Input Low Times	70		ns	[2,4]
8b	TwIL	Interrupt Request Input Low Times	5 TpC		ns	[2,5]
9	TwIH	Interrupt Request Input High Times	5 TpC		ns	[2,3]

Notes:

- [1] Clock timing references use $0.85V_{CC}$ for a logic 1 and 0.8V for a logic 0.
- [2] Timing references use 2.0V for a logic 1 and 0.8V for a logic 0.
- [3] Interrupt references request through Port 3.
- [4] Interrupt request through Port 3 (P33-P31).
- [5] Interrupt request through Port 30.

Pre-Characterization Product:

The product represented by this CPS is newly introduced and Zilog has not completed the full characterization of the product. The CPS states what Zilog knows about this product at this time, but additional features or non-con-

formance with some aspects of the CPS may be found, either by Zilog or its customers in the course of further application and characterization work. In addition, Zilog cautions that delivery may be uncertain at times, due to start-up yield issues.

© 1996 by Zilog, Inc. All rights reserved. No part of this document may be copied or reproduced in any form or by any means without the prior written consent of Zilog, Inc. The information in this document is subject to change without notice. Devices sold by Zilog, Inc. are covered by warranty and patent indemnification provisions appearing in Zilog, Inc. Terms and Conditions of Sale only. Zilog, Inc. makes no warranty, express, statutory, implied or by description, regarding the information set forth herein or regarding the freedom of the described devices from intellectual property infringement. Zilog, Inc. makes no warranty of merchantability or fitness for any purpose. Zilog, Inc. shall not be responsible for any errors that may appear in this document. Zilog, Inc. makes no commitment to update or keep current the information contained in this document.

Zilog's products are not authorized for use as critical components in life support devices or systems unless a specific written agreement pertaining to such intended use is executed between the customer and Zilog prior to use. Life support devices or systems are those which are intended for surgical implantation into the body, or which sustains life whose failure to perform, when properly used in accordance with instructions for use provided in the labeling, can be reasonably expected to result in significant injury to the user.

Zilog, Inc. 210 East Hacienda Ave.
Campbell, CA 95008-6600
Telephone (408) 370-8000
FAX 408 370-8056
Internet: <http://www.zilog.com>