



## HIGH FIDELITY *PowerSpeech™*

### **Table of Contents-**

1.	GENERAL DESCRIPTION .....	2
2.	FEATURES .....	2
3.	BLOCK DIAGRAM .....	3
4.	PIN DESCRIPTION.....	4
5.	FUNCTIONAL DESCRIPTION.....	5
5.1	Register Definition and Control.....	5
5.2	Option Control Function.....	8
5.3	Interrupt Vector Allocation .....	8
5.4	CPU Interface .....	10
6.	ELECTRICAL CHARACTERISTICS.....	13
6.1	Absolute Maximum Ratings.....	13
6.2	DC Characteristics.....	13
6.3	AC Characteristics.....	14
7.	BONDING PAD DIAGRAM .....	15
8.	TYPICAL APPLICATION CIRCUIT.....	17
8.1	DAC Output .....	17
8.2	PWM Output.....	18
9.	REVISION HISTORY .....	19



## 1. GENERAL DESCRIPTION

The W523Axxx family are programmable speech synthesis ICs that utilize Winbond's new high fidelity voice synthesis algorithm to generate all types of voice effects with high sound quality.

The W523Axxx's LOAD, JUMP, MOVE and INC commands and ten programmable registers provide powerful user-programmable functions that make this chip suitable for an extremely wide range of speech IC applications.

The W523Axxx family includes 14 kinds of part numbers with same function except for the voice duration shown below:

PART NO.	W523A008	W523A010	W523A012	W523A015	W523A020	W523A025	W523A030
Duration	8 sec.	10 sec.	12 sec.	15 sec.	20 sec.	25 sec.	30 sec.
PART NO.	W523A040	W523A050	W523A060	W523A070	W523A080	W523A100	W523A120
Duration	40 sec.	50 sec.	60 sec.	70 sec.	80 sec.	100 sec.	120 sec.

Note: The voice duration is estimated by various sampling rate.

## 2. FEATURES

- Operating voltage range: 2.4 – 5.5 volts
- New high fidelity synthesis algorithm
- Either PWM mode or D/A converter mode can be selected for AUD output
- Provides 4 direct trigger inputs that can easily be extended to 24 matrix trigger inputs
- Two trigger input debounce times (50 mS or 400 uS) can be set
- Provides up to 2 LEDs and 5 STOP outputs
- Flexible functions programmable through the following:
  - LD (Load), JP (Jump), MV (Move) and INC (Increase) commands
  - Four general purpose registers: R0, R1, R2 and R3
  - Six special purpose registers: EN0, EN1 (excludes W523A008 and W523A010), MODE0, MODE1, STOP and PAGE
  - Conditional instructions: @LAST, @TGn\_HIGH or LOW, where, n = 1,2,5 or 6 for W523A012 ~ W523A120; n=1,2,3 or 4 for W523A008 and W523A010
  - Speech equations
  - END instruction
- Supports CPU interface operation
- Symbolic compiler supported
- Instruction cycle  $\leq 400 \mu\text{S}$  typically
- Section control for
  - Variable frequency: 4.8/6/8/12 KHz
  - LED: ON/OFF
- Up to 256 voice groups can be used in single page mode; or extended to 2,048 voice groups in multi page mode, such as 8-page, 16-page and 32-page.

## 3. BLOCK DIAGRAM

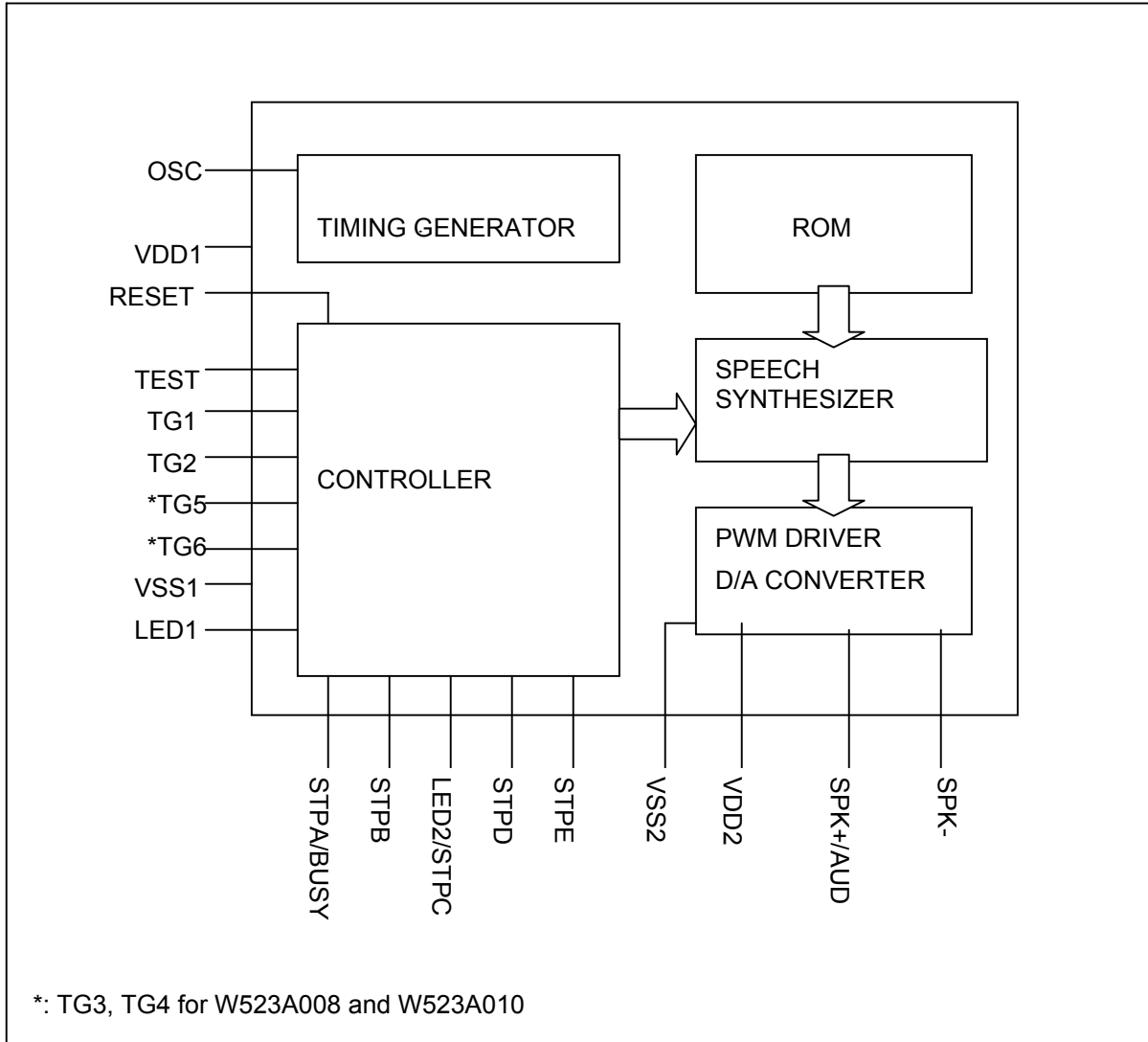

#### 4. PIN DESCRIPTION

NAME	I/O	DESCRIPTION
OSC	I	Ring oscillator input
VDD1	-	Positive power supply
TEST	I	Test pin. Internally pulled low
$\overline{\text{RESET}}$	I	Active low to reset all devices as POR function. Internally pulled high.
TG1	I	Direct trigger input 1. Internally pulled high
TG2	I	Direct trigger input 2. Internally pulled high
*TG5	I	Direct trigger input 5. Internally pulled high
*TG6	I	Direct trigger input 6. Internally pulled high
VSS1	-	Negative power supply
LED1	O	LED1 output
STPA/BUSY	O	Stop signal A or Busy signal
STPB	O	Stop signal B
LED2/STPC	O	LED2 output or Stop signal C
STPD	O	Stop signal D
STPE	O	Stop signal E
SPK-	O	PWM output
AUD/SPK+	O	Current type output or PWM output for speaker
VSS2	-	Negative power supply
VDD2	-	Positive power supply

\*: TG3, TG4 for W523A008 and W523A010



## 5. FUNCTIONAL DESCRIPTION

### I/O pins:

The W523Axxx family provides up to 4 trigger pins, which can be extended to 24 matrix trigger inputs, up to 5 STOP output pins and up to 2 LED output pins. All of these I/O pins' status can be easily defined by *PowerSpeech™* program.

### Powerful programmable features:

The W523Axxx family provides JUMP (JP), LOAD (LD), MOVE (MV), INC, and END commands and 10 programmable registers, such as R0 ~ R3, EN0, EN1, MODE0, MODE1, STOP and PAGE, can be easily used to program the desired playing mode, stop output signal form, LED flash type, and trigger pin interrupt modes. The chip's programmable features can also be used to develop new, customized functions for a wide variety of innovative applications.

### Programmable Power-on Initialization:

Whenever the W523Axxx is powered on or pressed the  $\overline{\text{RESET}}$  pin, the program contained in the 32<sup>nd</sup> voice group will be executed after the power-on delay (about 160 mS), so the user can write a program into this group to set the power-on initial state. If user does not wish to execute a program at power-on, an "END" instruction should be entered in the group 32.

The interruption priority is shown as below while other trigger pins as well as JUMP (JP) command are executing simultaneously during POI executing period:

POI > TG1F > TG1R > TG2F > TG2R > \*TG5F > \*TG5R > \*TG6F > \*TG6R > "JP" instruction.

\*: TG3, TG4 for W523A008, W523A010

### 5.1 Register Definition and Control

The register file in the W523Axxx family is composed of 10 registers, including 4 general-purpose registers and 6 special purpose registers. They are defined to facilitate the operations for various purposes. The default setting values of the registers are given in the following table.

REGISTER	NAME	DEFAULT SETTING
General Register	R0-R3	00100000B
Special Register	EN0 (W523A008~A010)	11111111B
	EN0 (W523A012~A120)	XX11XX11B
	EN1 (W523A012~A120)	XX11XX11B
	MODE0, MODE1	11111111B
	STOP	XXX11111B
	PAGE	00000000B

### 5.1.1 MODE0 Register

BIT	DESCRIPTION	DEFINITION
7	LED mode	1: Flash
		0: DC
6	LED2/STPC pin selection	1: LED2 output
		0: STPC output
4	Debounce time	1: Long
		0: Short
2	STPA/BUSY pin selection	1: STPA output
		0: BUSY output
5,3,1,0	X	Don't care

The MODE0.7 bit defines the output type of LED1 and LED2 pins as Flash output (3 Hz) or DC output. The MODE0.6 bit defines the configuration of LED2/STPC pin's status as LED2 output or STPC output. The MODE0.4 bit defines the trigger pin's debounce time as long debounce (50 mS) or short debounce (400 uS). The MODE0.2 bit defines the behavior of the STPA/BUSY pin as STPA output in normal mode or BUSY signal output in CPU mode. The bits 5, 3, 1 and 0 are don't care bits.

### 5.1.2 MODE1 Register

BIT	DESCRIPTION	DEFINITION
7, 6, 1, 0	X	Don't care
5	LED Flash type	1: Alternate
		0: Synchronous
4	LED1 section control	1: YES
		0: NO
3	LED2 control	1: SECTION control
		0: STPC control
2	LED1 volume control	1: OFF
		0: ON

MODE1.5 is for LED flash type control. MODE1.4 is for LED1 section control ON/OFF. MODE1.3 is for LED2 Section/STPC control. MODE1.2 is for LED1 volume control.



### 5.1.3 PAGE Register

BIT	7	6	5	4	3	2	1	0
PAGE	-	-	-	PG4	PG3	PG2	PG1	PG0

The bits 0 ~ 4 in PAGE register are used for page selection. Once the page mode being defined (referring to the below section of "Option Control Function"), the working page is selected by the bits 0 ~ 4 in the PAGE register. Hence, the user can execute "LD PAGE, value" instruction to change the working page of the voice entry group. Not all of the bits 0 ~ 4 of PAGE register are used in different page mode. They are listed as below table:

PAGE MODE	PG4	PG3	PG2	PG1	PG0
1-page	x	x	x	x	x
8-page	x	x	√	√	√
16-page	x	√	√	√	√
32-page	√	√	√	√	√

Where "x" means don't care and "√" means must be set properly.

### 5.1.4 EN Register (W523A012 ~ W523A120)

BIT	7	6	5	4	3	2	1	0
EN0	X	X	TG2R	TG1R	X	X	TG2F	TG1F
EN1	X	X	TG6R	TG5R	X	X	TG6F	TG5F

EN Register (W523A008, W523A010)

BIT	7	6	5	4	3	2	1	0
EN0	TG4R	TG3R	TG2R	TG1R	TG4F	TG3F	TG2F	TG1F

EN0 or EN1 is an 8-bit register that stores the rising/falling edge enable or disable status information for all trigger pins, which determines whether each trigger pin is retriggerable, non-retriggerable, overwrite, or non-overwrite. The 8-bit structure of this register and the rising or falling edge of the triggers corresponding to each bit are shown above. "X" indicates a "don't care" bit.

The TG1, 2, 5, 6 represents triggers 1, 2, 5 and 6 respectively; the "R" represents the rising edge; and "F" represents the falling edge. When any one of the eight bits is set to "1", the rising or falling edge of the corresponding trigger pin can be enabled, interrupting the current state.

### 5.1.5 STOP Register

BIT	7	6	5	4	3	2	1	0
STOP	X	X	X	STE	STD	STC	STB	STA



The STOP register stores stop output status information to determine the voltage level of each stop output pin. The 8-bit structure of this register and the stop output pin corresponding to each bit are shown as above table. The "X" indicates a "don't care" bit. When a particular STOP bit is set to "1", the corresponding stop signal will be an active high output.

### 5.1.6 R0-R3 Registers

These four registers are 8-bit register that stores the entry values of from 0 to 255 voice groups. R0 is a special register that can be incremented by "INC" instruction.

## 5.2 Option Control Function

There are four types of option control in W523Axxx. They can be determined by a declaration in the user's program file, but cannot be controlled by register.

FUNCTION	MASK OPTION DECLARATION	DEFINITION
Page mode configuration	DEFPAGE 1	256 interrupt vector/label for 1 page, 1 page in total (1-page mode)
	DEFPAGE 8	256 interrupt vector/label for 1 page, 8 pages in total (8-page mode)
	DEFPAGE 16	128 interrupt vector/label for 1 page, 16 pages in total (16-page mode)
	DEFPAGE 32	64 interrupt vector/label for 1 page, 32 pages in total (32-page mode)
Operation mode	NORMAL	Normal mode operation
	CPU	CPU mode operation
Oscillator frequency	OSC_3MHz	3 MHz oscillator
	OSC_1.5MHz	1.5 MHz oscillator
Voice output type	VOUT_DAC	DAC (AUD) output
	VOUT_PWM	PWM output

"DEFPAGE" determines the page operation mode in W523Axxx. The default setting of the page mode is 1-page mode. The 8-page, 16-page or 32-page mode can be declared to extend the voice group entry from 256 to 2047 in *PowerSpeech™* program.

The W523Axxx can communicate with an external microprocessor through the simple serial CPU interface, which is the same as the W583Sxx series. The CPU interface consists of the TG1, TG2, and STPA/BUSY pins. "NORMAL" and "CPU" decide whether the operation mode of W523Axxx will be normal mode or CPU mode.

"OSC\_3MHz" and "OSC\_1.5MHz" select the frequency of the system clock. "VOUT\_DAC" and "VOUT\_PWM" select the voice output type.

### 5.3 Interrupt Vector Allocation

The W523Axxx provides a total of 4 trigger inputs to communicate with the outside world. Each trigger pin can invoke 2 dedicated interrupt vectors depending on TG pins' status (rising or falling). The table below shows the relationship between triggers' status and interrupt vectors.



# W523AXXX



For W523A008 and W523A010:

INTERRUPT VECTOR	TRIGGER SOURCE
0	TG1F
1	TG2F
2	TG3F
3	TG4F
INTERRUPT VECTOR	TRIGGER SOURCE
4	TG1R
5	TG2R
6	TG3R
7	TG4R
32	POI

For W523A012 ~ W523A120:

INTERRUPT VECTOR	TRIGGER SOURCE
0	TG1F
1	TG2F
8	TG5F
9	TG6F
INTERRUPT VECTOR	TRIGGER SOURCE
4	TG1R
5	TG2R
12	TG5R
13	TG6R
32	POI

## 5.4 CPU Interface

The W523Axxx can communicate with an external microprocessor through a simple serial CPU interface. The CPU interface consists of TG1, TG2 and STPA/BUSY pins, which are shown below:

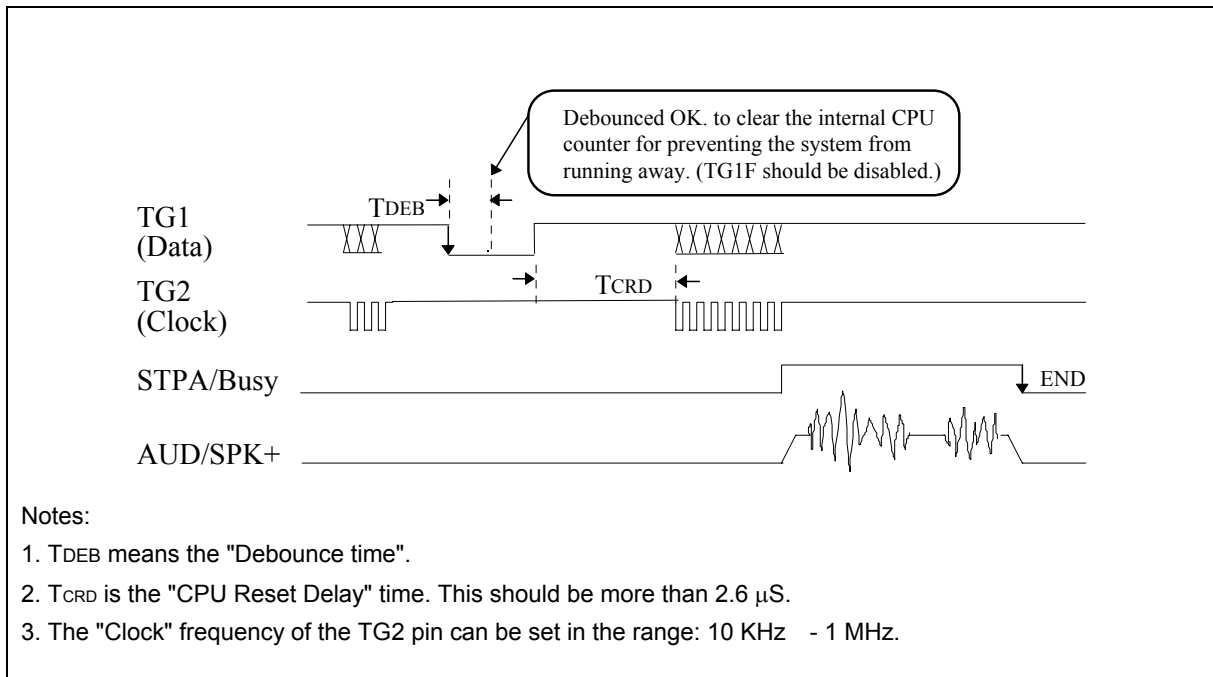

Busy signal will output "high" after the end of transmission. The rising timing of Busy signal is dependent on the MSB of data output on TG1 (Data) pin. If MSB is "1", Busy will rise after the last rising edge of TG2 (Clock) pin. If MSB is "0", Busy will rise after the rising edge that TG1 (Data) returns to high.

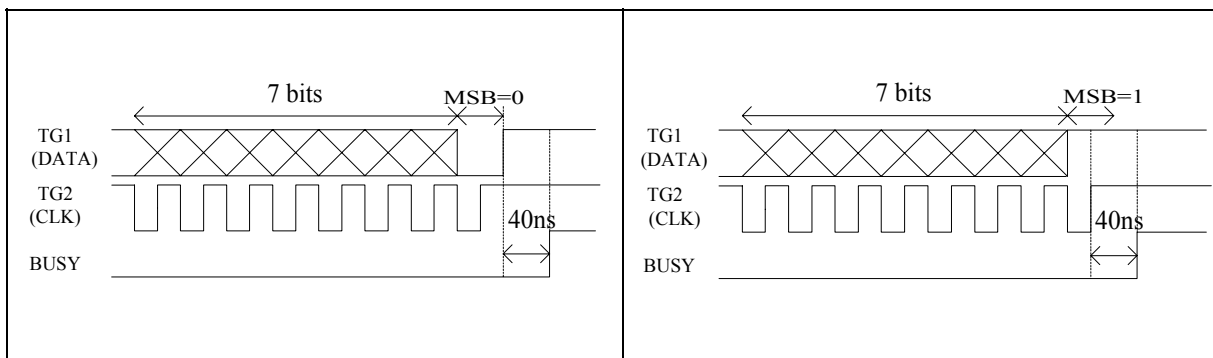



To place the W523Axxx in CPU mode, program the code according to the following example.

```

W523A015
CPU; Reserved word, used as a directive to notify the compiler for post processing.
LED1
FREQ2
POI:
    LD MODE0,XX1XX0XXB ;bit2=0 BUSY
    LD EN0, 0x00
    H5+voice1+T5
    END
34: ; Direct trigger or CPU interrupt.
    H5+voice2+T5
    END
    
```

The defaulted operating mode in W523Axxx is normal mode (or manual trigger mode), which is identified by the "Normal" and "CPU" option control. To enter the CPU mode, the "CPU" declaration must be inserted in the declaration region of program (\*.out). In CPU mode, the bit MODE0.2, which is defined as STPA or BUSY selection for the STPA/BUSY pin, will be selected as "0" (BUSY output) automatically by the compiler unless otherwise specified explicitly by the STPA directive. The CPU, STPA, and BUSY directives can appear only in the first paragraph of the \*.out files so that the compiler will automatically interpret them as Stop definitions in the POI interrupt vector. If these directives are placed elsewhere, an error message will be issued during the compilation process.

In the program example shown above, the external  $\mu\text{C}$  will transfer one byte data "34" to W523Axxx. The number 34 (Decimal) is equal to 00100010b (Binary). The interface timing is shown below.

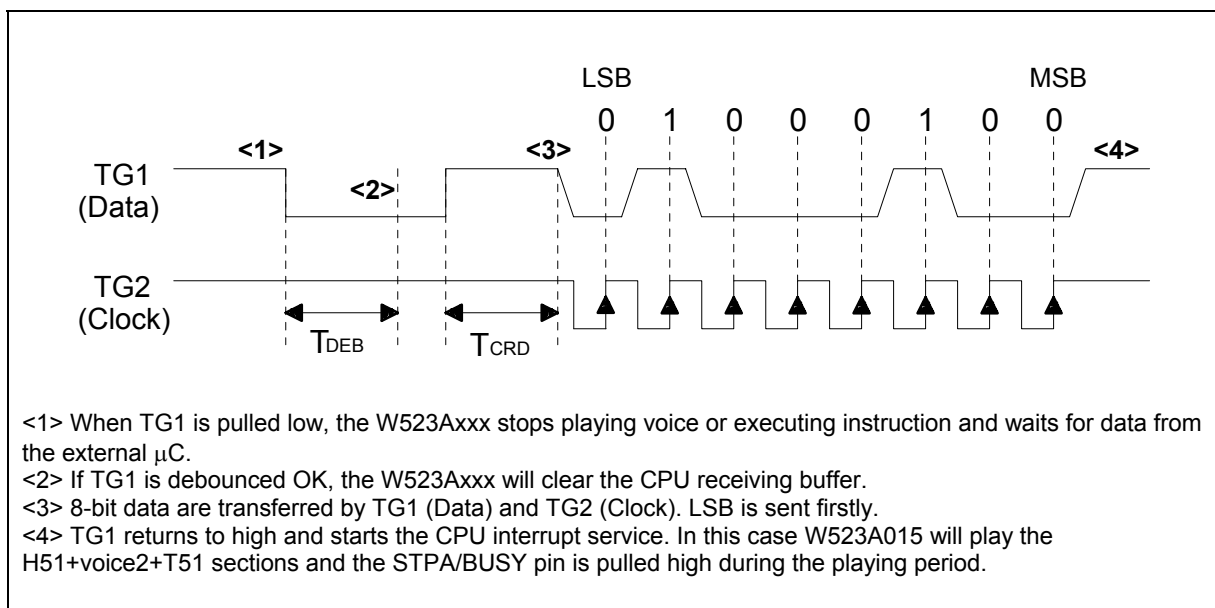



The TG1 pin, which is pulled high with a 500KΩ resistor, should be kept high during non-transmission periods to reduce power consumption. The external μC should be connected to the W523Axxx by an inverted-type output port for better noise immunity. In CPU mode, the W523Axxx stops operating upon the falling edge of the TG1 pin. For the CPU interface to work normally, TG1F should be disabled. Thus, one suggestion is that TG1F, TG1R, TG2F, and TG2R should all be disabled in CPU mode. The master frequency of the external μC, and hence the clock rate of TG1 and TG2, tends to vary among different vendors and applications.

Note: In CPU mode application, in case the last voice group entry point, 255, is no used, it should be typed “END” command to avoid abnormal operating.

### **Instruction Set List**

There are two types of instruction in the W523Axxx, unconditional and conditional instructions. The first types of instructions are executed immediately after they are issued. The second types of instructions are executed only when the conditions specified in the instruction are satisfied. All the instructions are listed in the following table. The cycle time for each instruction is 2/Sampling Frequency (Fs). For example, Fs = 6.0 KHz, the cycle time is 333 μS.

UNCONDITIONAL		CONDITIONAL		
JP	G	JP	G	@STS
JP	Rn	JP	Rn	@STS
LD	EN0, value	LD	EN0, value	@STS
LD	EN1, value	LD	EN1, value	@STS
LD	MODEi, value	LD	MODEi, value	@STS
LD	STOP, value	LD	STOP, value	@STS
LD	PAGE, value	LD	PAGE, value	@STS
LD	Rn, value	LD	Rn, value	@STS
END		END		@STS
MV	Rn, Rm	MV	Rn, Rm	@STS
INC		INC		@STS

Legend:

G: Interrupt vector/label

Rn: R0-R3

Rm: R0-R3

MODEi: MODE0, MODE1

value: 8-bit data

@STS can be the following: @LAST, @TGn\_HIGH, @TGn\_LOW, n = 1–4 (W523A008, W523A010), n = 1,2,5,6 (W523A012~A120).



## 6. ELECTRICAL CHARACTERISTICS

### 6.1 Absolute Maximum Ratings

PARAMETER	SYMBOL	CONDITIONS	RATED VALUE	UNIT
Power Supply	VDD-VSS	-	-0.3 to +7.0	V
Input Voltage	VIN	All Inputs	VSS -0.3 to VDD +0.3	V
Storage Temp.	TSTG	-	-55 to +150	°C
Operating Temp.	TOPR	-	0 to +70	°C

Note: Exposure to conditions beyond those listed under Absolute Maximum Ratings may adversely affect the life and reliability of the device.

### 6.2 DC Characteristics

( $T_A = 25^\circ\text{C}$ ,  $V_{SS} = 0\text{V}$ )

PARAMETER	SYM.	CONDITIONS	MIN.	TYP.	MAX.	UNIT
Operating Voltage	VDD	DAC output	2.4	3.0	5.5	V
		PWM output	2.4	3.0	5.5	V
Input Voltage	VIL		VSS -0.3	-	$0.3 \times V_{DD}$	V
	VIH		$0.7 \times V_{DD}$	-	VDD	
Standby Current	ISB1	VDD = 3V, All I/O pins unconnected, No Playing			1	$\mu\text{A}$
	ISB2	VDD = 5V, All I/O pins unconnected, No Playing			1	$\mu\text{A}$
Operating Current (Ring type)	IOP1	VDD = 3V, No Load			500	$\mu\text{A}$
	IOP2	VDD = 5V, No Load			1	mA
Input Current of TG pins	IIN1	VDD = 3V, Vin = 0V			-8	$\mu\text{A}$
Input Current of TEST pin	IIN2	VDD = 3V, Vin = 3V			30	$\mu\text{A}$
Input Current of SEL, $\overline{\text{RESET}}$	IIN3	VDD = 3V, Vin = 0V			-8	$\mu\text{A}$
SPK (D/A Full Scale)	IDAC	VDD = 4.5V, RI = 100 $\Omega$	-4.0	-5.0	-6.0	mA
Output Current of STPA-STPE	IOL1	VDD = 3V, Vout = 0.4V	0.8			mA
	IOH1	VDD = 3V, Vout = 2.7V	-0.8			mA
Output Current of SPK+, SPK-	IOL2	VDD = 3V, RI = 8 $\Omega$	100			mA
	IOH2		-100			mA



## 6.3 AC Characteristics

PARAMETER	SYM.	CONDITIONS	MIN.	TYP.	MAX.	UNIT
Oscillation Frequency (W58300 ICE chip)	Fosc1	Ring oscillator, Rosc = 270 KΩ	2.7	3	3.3	MHz
		Ring oscillator, Rosc = 560 KΩ	1.3	1.5	1.7	MHz
Oscillation Frequency (W523Axxx production chip)	Fosc2	Ring Oscillator, Rosc = 750 KΩ	2.7	3	3.3	MHz
		Ring Oscillator, Rosc = 1.6 MΩ	1.3	1.5	1.7	MHz
Oscillation Frequency Deviation by Voltage Drop	$\frac{\Delta F_{osc2}}{F_{osc2}}$	$\frac{F(3V)-F(2.4V)}{F(3V)}$			7.5	%
Instruction Cycle Time	Tins	Fosc = 3 MHz, SR = 6 KHz		1/3		mS
POI Delay Time	TPD	Fosc = 3 MHz		160		mS
Long Debounce Time	TDEBL	Fosc = 3 MHz, SR = 6 KHz	50			mS
Short Debounce Time	TDEBS		400			μS



## 7. BONDING PAD DIAGRAM

(For W523A008 and W523A010 only)

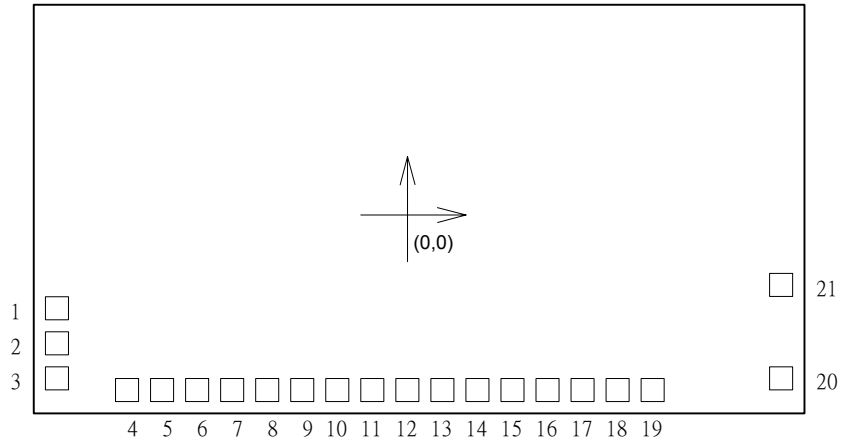

PAD NO.	PAD NAME	PAD NO.	PAD NAME
1	VDD	12	LED1
2	OSC	13	STPA/BUSY
3	X	14	STPB
4	TEST	15	LED2/STPC
5	$\overline{\text{RESET}}$	16	STPD
6	TG1	17	STPE
7	TG2	18	VSS1
8	TG3	19	VDD1
9	TG4	20	SPK-
10	VSS	21	AUD/SPK+
11	NC	-	-

NC means "No Connection"

# W523AXXX



(For W523A012 ~ W523A120)

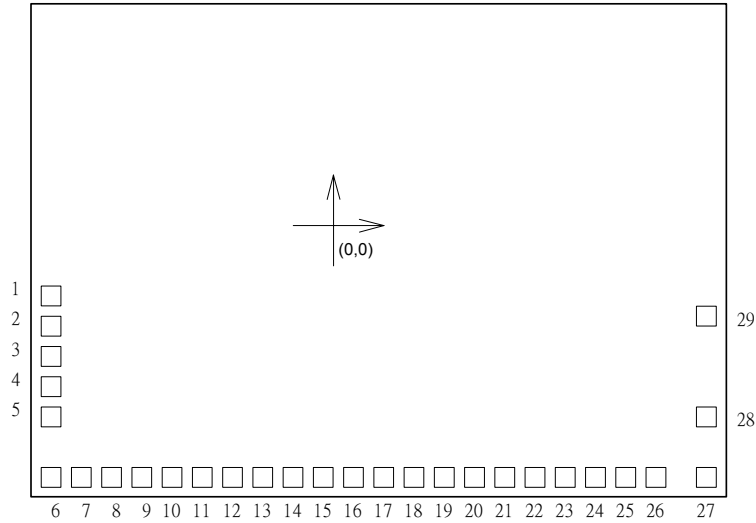

PAD NO.	PAD NAME	PAD NO.	PAD NAME
1	VDD	16	NC
2	OSC	17	LED1
3	NC	18	STPA/BUSY
4	NC	19	STPB
5	TEST	20	LED2/STPC
6	$\overline{\text{RESET}}$	21	STPD
7	TG1	22	STPE
8	TG2	23	NC
9	NC	24	NC
10	NC	25	NC
11	TG5	26	VSS1
12	TG6	27	VDD1
13	NC	28	SPK-
14	NC	29	AUD/SPK+
15	VSS	-	-

NC: means "No Connection"



## 8. TYPICAL APPLICATION CIRCUIT

### 8.1 DAC Output

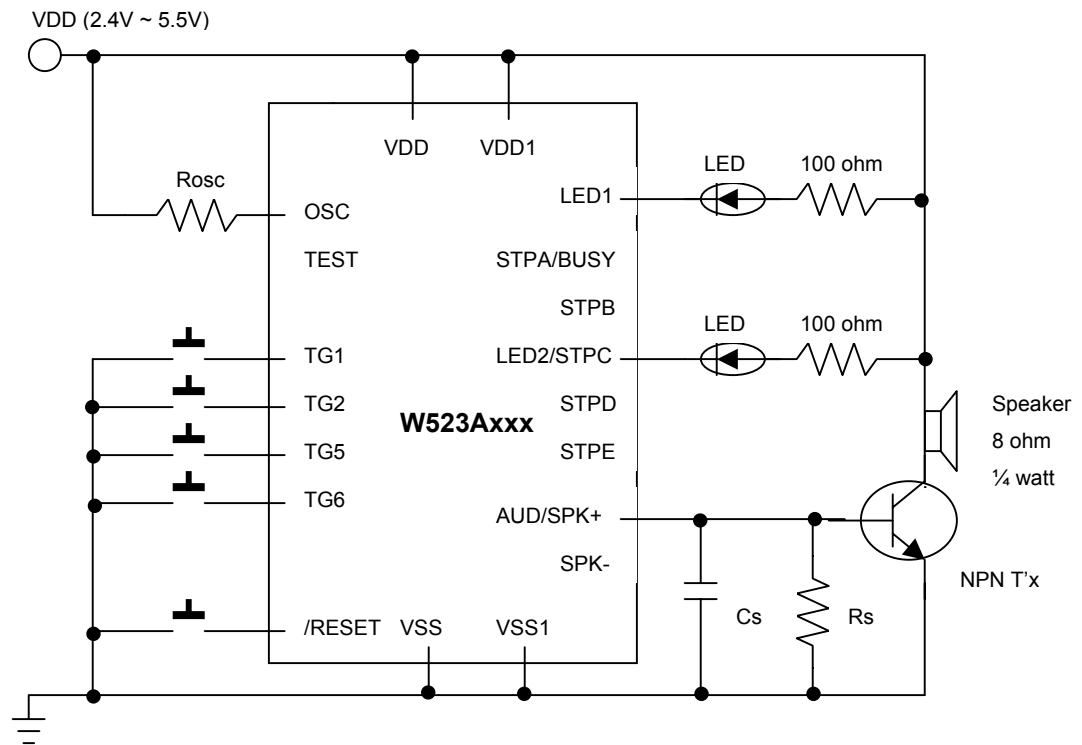

#### Notes:

1. In principle, the playing speed determined by Rosc should correspond to the sampling rate during the coding phase. The playing speed may be adjusted by varying Rosc, however.
2. Rs is an optional current-dividing resistor. If Rs is added, the resistance should be between 390 and 820 ohm.
3. The typical Rosc = 750 Kohm for 3 MHz Fosc; and Rosc = 1.6 Mohm for 1.5 MHz Fosc.
4. Cs is optional.
5. The DC current gain of the NPN transistor ranges from 120 to 200.
6. All unused trigger pins can be left open because of their internal pull-high resistance.
7. The OSC layout in customer's PCB should be as closed as the OSC pad to avoid noise coupling.
8. The chip's substrate must be wired to Vss.
9. W523A008~A010's trigger pins are TG1, TG2, TG3, TG4; W523A012~W523A120's trigger pins are TG1, TG2, TG5, TG6.

## 8.2 PWM Output

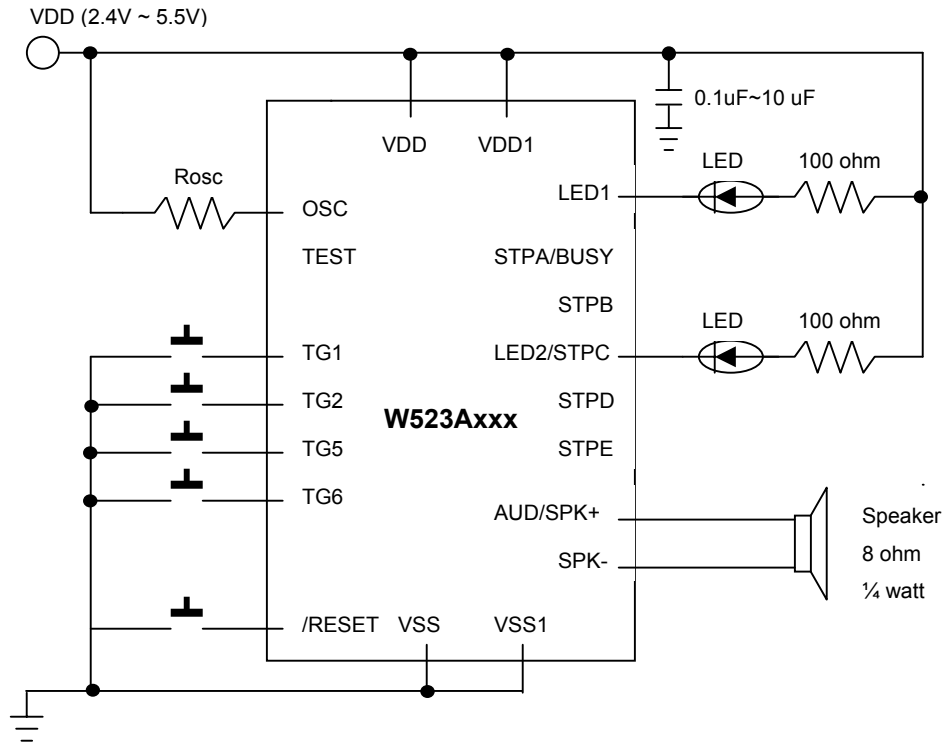

### Notes:

1. In principle, the playing speed determined by Rosc should correspond to the sampling rate during the coding phase. The playing speed may be adjusted by varying Rosc, however.
2. The typical Rosc = 750 Kohm for 3 MHz Fosc; and Rosc = 1.6 Mohm for 1.5 MHz Fosc.
3. The capacity, 0.1uF~10 uF, is necessary to reduce voltage fluctuation while PWM outputting.
4. All unused trigger pins can be left open because of their internal pull-high resistance.
5. The OSC layout in customer's PCB should be as closed as the OSC pad to avoid noise coupling.
6. The chip's substrate must be wired to Vss.
7. W523A008~A010's trigger pins are TG1, TG2, TG3, TG4; W523A012~W523A120's trigger pins are TG1, TG2, TG5, TG6.



## 9. REVISION HISTORY

VERSION	DATE	EDITOR	DESCRIPTION
A1	Dec. 1, 2001	Steven Lin	Initial Issued
A2	Feb. 6, 2002	Steven Lin	Page 1, line 6, "14 kinds of bodies" → "14 kinds of part numbers". Page1, line 7, Note: "by 6.4K..." → "by various..."
A3	May 20, 2003	Steven Lin	Page 11, ROSC = 750 Kohm for 3 MHz Page 11, ROSC = 1.6 Mohm for 1.5 MHz



**Headquarters**  
No. 4, Creation Rd. III,  
Science-Based Industrial Park,  
Hsinchu, Taiwan  
TEL: 886-3-5770066  
FAX: 886-3-5665577  
<http://www.winbond.com.tw/>

**Taipei Office**  
9F, No.480, Rueiguang Rd.,  
Neihu District, Taipei, 114,  
Taiwan, R.O.C.  
TEL: 886-2-8177-7168  
FAX: 886-2-8751-3579

**Winbond Electronics Corporation America**  
2727 North First Street, San Jose,  
CA 95134, U.S.A.  
TEL: 1-408-9436666  
FAX: 1-408-5441798

**Winbond Electronics Corporation Japan**  
7F Daini-ueno BLDG, 3-7-18  
Shinyokohama Kohoku-ku,  
Yokohama, 222-0033  
TEL: 81-45-4781881  
FAX: 81-45-4781800

**Winbond Electronics (Shanghai) Ltd.**  
27F, 2299 Yan An W. Rd. Shanghai,  
200336 China  
TEL: 86-21-62365999  
FAX: 86-21-62365998

**Winbond Electronics (H.K.) Ltd.**  
Unit 9-15, 22F, Millennium City,  
No. 378 Kwun Tong Rd.,  
Kowloon, Hong Kong  
TEL: 852-27513100  
FAX: 852-27552064

*Please note that all data and specifications are subject to change without notice.  
All the trade marks of products and companies mentioned in this data sheet belong to their respective owners.*