

The documentation and process conversion measures necessary to comply with this revision shall be completed by 1 October 2004.

INCH-POUND

MIL-PRF-19500/452G
1 July 2004
SUPERSEDING
MIL-PRF-19500/452F
18 September 2003

* PERFORMANCE SPECIFICATION SHEET

SEMICONDUCTOR DEVICE, DIODE, SILICON, LOW LEVEL VOLTAGE-REFERENCE, TEMPERATURE COMPENSATED, TYPES 1N4565A-1 THROUGH 1N4584A-1, AND 1N4565AUR-1 THROUGH 1N4584AUR-1, JAN, JANTX, JANTXV, JANS, JANHC, AND JANKC, RADIATION HARDENED (TOTAL DOSE ONLY) TYPES JANTXVM, D, L, R, F, G, H; JANSM, D, L, R, F, G, H; JANHCM, D, L, R, F, G, H; AND JANKCM, D, L, R, F, G, H

This specification is approved for use by all Departments and Agencies of the Department of Defense.

* The requirements for acquiring the product described herein shall consist of this specification sheet and MIL-PRF-19500.

1. SCOPE

* 1.1 Scope. This specification covers the performance requirements for 6.4 volts ± 5 percent, silicon, low bias current, voltage-reference, temperature compensated diodes. Four levels of product assurance are provided for each encapsulated device type as specified in MIL-PRF-19500, and two levels of product assurance for each unencapsulated device type die. Seven levels of radiation hardened (total dose only) product assurance are provided for each encapsulated device type, and two levels of product assurance for each unencapsulated device type die as specified in MIL-PRF-19500.

1.2 Physical dimensions. See figure 1 (DO-7 and DO-35), figure 2 (DO-213AA), figure 3 (JANHCA and JANKCA), figure 4 (JANHCB and JANKCB), and figure 5 (JANHCC and JANKCC).

1.3 Maximum ratings. (Unless otherwise specified $T_A = +25^\circ\text{C}$).

P_T	T_{STG} and T_J	I_{ZM} (1)	Power derating above $T_A = +25^\circ\text{C}$
<u>mW</u>	<u>$^\circ\text{C}$</u>	<u>mA dc</u>	<u>mW/$^\circ\text{C}$</u>
500	-55 to +175	70	3.33

(1) To guarantee voltage temperature stability, it is necessary to maintain the proper I_Z as specified in 1.4 herein.

* Comments, suggestions, or questions on this document should be addressed to Defense Supply Center, Columbus, ATTN: DSCC-VAC, P.O. Box 3990, Columbus, OH 43218-3990, or emailed to Semiconductor@dsc.dla.mil. Since contact information can change, you may want to verify the currency of this address information using the ASSIST Online database at <http://www.dodssp.daps.mil>.

MIL-PRF-19500/452G

1.4 Primary electrical characteristics. Unless otherwise specified, primary electrical characteristics at $T_A = +25^\circ\text{C}$.

Type (1) (2)	ΔV_Z (voltage-temperature stability)	Z_Z $I_Z = 0.5 \text{ mA dc}$	V_Z $I_Z = 0.5 \text{ mA dc}$		I_R $V_R = 3.0 \text{ V}$
			Min	Max	
1N4565A-1, 1N4565AUR-1	<u>V dc</u> 0.100	<u>ohms</u> 200	<u>Volts</u> 6.08	<u>Volts</u> 6.72	<u>μA</u> 2.0
1N4566A-1, 1N4566AUR-1	0.050	200	6.08	6.72	2.0
1N4567A-1, 1N4567AUR-1	0.020	200	6.08	6.72	2.0
1N4568A-1, 1N4568AUR-1	0.010	200	6.08	6.72	2.0
1N4569A-1, 1N4569AUR-1	0.005	200	6.08	6.72	2.0
Type (1)	ΔV_Z (voltage-temperature Stability)	Z_Z $I_Z = 1.0 \text{ mA dc}$	V_Z $I_Z = 1.0 \text{ mA dc}$		I_R $V_R = 3.0 \text{ V}$
			Min	Max	
1N4570A-1, 1N4570AUR-1	<u>V dc</u> 0.100	<u>ohms</u> 100	<u>Volts</u> 6.08	<u>Volts</u> 6.72	<u>μA</u> 2.0
1N4571A-1, 1N4571AUR-1	0.050	100	6.08	6.72	2.0
1N4572A-1, 1N4572AUR-1	0.020	100	6.08	6.72	2.0
1N4573A-1, 1N4573AUR-1	0.010	100	6.08	6.72	2.0
1N4574A-1, 1N4574AUR-1	0.005	100	6.08	6.72	2.0
Type (1)	ΔV_Z (voltage-temperature stability)	Z_Z $I_Z = 2.0 \text{ mA dc}$	V_Z $I_Z = 2.0 \text{ mA dc}$		I_R $V_R = 3.0 \text{ V}$
			Min	Max	
1N4575A-1, 1N4575AUR-1	<u>V dc</u> 0.100	<u>ohms</u> 50	<u>Volts</u> 6.08	<u>Volts</u> 6.72	<u>μA</u> 2.0
1N4576A-1, 1N4576AUR-1	0.050	50	6.08	6.72	2.0
1N4577A-1, 1N4577AUR-1	0.020	50	6.08	6.72	2.0
1N4578A-1, 1N4578AUR-1	0.010	50	6.08	6.72	2.0
1N4579A-1, 1N4579AUR-1	0.005	50	6.08	6.72	2.0
Type (1)	ΔV_Z (voltage-temperature Stability)	Z_Z $I_Z = 4.0 \text{ mA dc}$	V_Z $I_Z = 4.0 \text{ mA dc}$		I_R $V_R = 3.0 \text{ V}$
			Min	Max	
1N4580A-1, 1N4580AUR-1	<u>V dc</u> 0.100	<u>ohms</u> 25	<u>Volts</u> 6.08	<u>Volts</u> 6.72	<u>μA</u> 2.0
1N4581A-1, 1N4581AUR-1	0.050	25	6.08	6.72	2.0
1N4582A-1, 1N4582AUR-1	0.020	25	6.08	6.72	2.0
1N4583A-1, 1N4583AUR-1	0.010	25	6.08	6.72	2.0
1N4584A-1, 1N4584AUR-1	0.005	25	6.08	6.72	2.0

(1) Electrical characteristics and test conditions for " A-1, and AUR-1" devices are identical.

(2) To guarantee voltage temperature stability, it is necessary to maintain the proper I_Z as specified in 1.4 herein.

2. APPLICABLE DOCUMENTS

* 2.1 General. The documents listed in this section are specified in sections 3, 4, or 5 of this specification. This section does not include documents cited in other sections of this specification or recommended for additional information or as examples. While every effort has been made to ensure the completeness of this list, document users are cautioned that they must meet all specified requirements of documents cited in sections 3, 4, or 5 of this specification, whether or not they are listed.

2.2 Government documents.

* 2.2.1 Specifications, standards, and handbooks. The following specifications, standards, and handbooks form a part of this document to the extent specified herein. Unless otherwise specified, the issues of these documents are those cited in the solicitation or contract.

* DEPARTMENT OF DEFENSE SPECIFICATIONS

MIL-PRF-19500 - Semiconductor Devices, General Specification for.

* DEPARTMENT OF DEFENSE STANDARDS

MIL-STD-750 - Test Methods for Semiconductor Devices.

* (Copies of these documents are available online at <http://assist.daps.dla.mil/quicksearch/> or <http://www.dodssp.daps.mil> or from the Standardization Document Order Desk, 700 Robbins Avenue, Building 4D, Philadelphia, PA 19111-5094.)

2.3 Order of precedence. In the event of a conflict between the text of this document and the references cited herein, the text of this document takes precedence. Nothing in this document, however, supersedes applicable laws and regulations unless a specific exemption has been obtained.

3. REQUIREMENTS

3.1 General. The individual item requirements shall be as specified in MIL-PRF-19500 and as modified herein.

3.2 Qualification. Devices furnished under this specification shall be products that are manufactured by a manufacturer authorized by the qualifying activity for listing on the applicable qualified manufacturer's list (QML) before contract award (see 4.2 and 6.3).

3.3 Abbreviations, symbols, and definitions. The abbreviations, symbols, and definitions used herein shall be as specified in MIL-PRF-19500.

3.4 Interface and physical dimensions. The interface and physical dimensions shall be as specified in MIL-PRF-19500 and figures 1, 2, 3, 4, and 5 herein.

3.4.1 Lead finish. Lead finish shall be solderable in accordance with MIL-PRF-19500, MIL-STD-750, and herein. Where a choice of lead finish is desired, it shall be specified in the acquisition document (see 6.2).

3.4.2 Diode construction. These devices shall be constructed in a manner and using material which enable the diodes to meet the applicable requirements of MIL-PRF-19500 and this document.

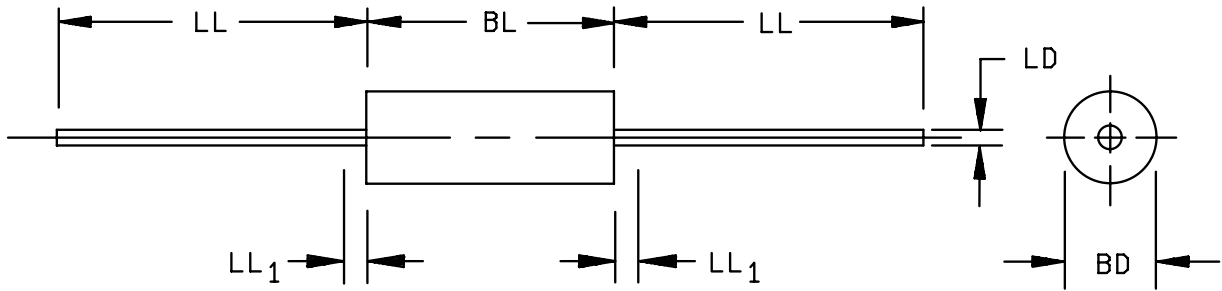

Symbol	Dimensions				Notes
	Inches		Millimeters		
	Min	Max	Min	Max	
BD	.060	.107	1.52	2.72	3
BL	.120	.300	3.05	7.62	3
LD	.018	.023	0.46	0.58	
LL	1.000	1.500	25.40	38.10	
LL ₁		0.050		1.27	4

NOTES:

1. Dimensions are in inches.
2. Millimeters are given for general information only.
3. Package contour optional within BD and length BL. Heat slugs, if any, shall be included within this cylinder but shall not be subject to minimum limit of BD.
4. Within this zone, lead diameter may vary to allow for lead finishes and irregularities, other than heat slugs.
5. In accordance with ASME Y14.5M, diameters are equivalent to ϕ x symbology.

FIGURE 1. Physical dimensions 1N4565A-1 through 1N4584A-1 (DO-7 and DO-35).

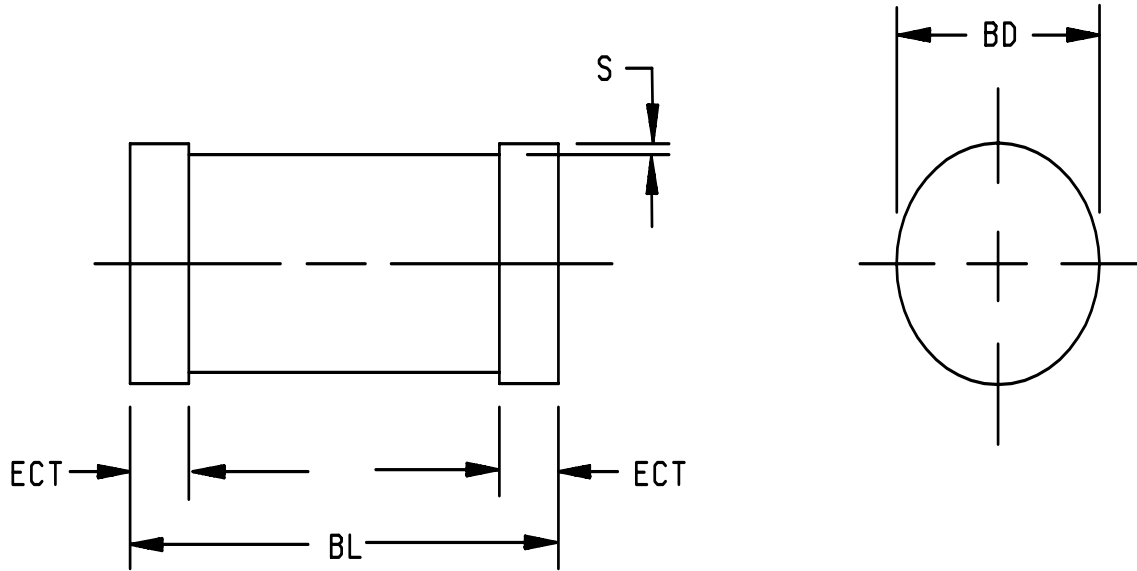

Symbol	Dimensions			
	Inches		Millimeters	
	Min	Max	Min	Max
BD	.063	.067	1.60	1.70
ECT	.016	.022	0.41	0.56
BL	.130	.146	3.30	3.71
S	.001 Min		0.03 Min	

NOTES:

1. Dimensions are in inches.
2. Millimeters are given for general information only.
3. In accordance with ASME Y14.5M, diameters are equivalent to ϕx symbology.

FIGURE 2. Physical dimensions 1N4565AUR-1 through 1N4584AUR-1 (DO-213AA).

Symbol	Dimensions			
	Inches		Millimeters	
	Min	Max	Min	Max
A	.0280	.0320	.711	.813
B	.0080	.0100	.203	.254
C	.0104	.0106	.264	.269
D	.0019	.0021	.048	.053
E	.0054	.0056	.137	.142
F	.0020	.0040	.050	.102
G	.0280	.0320	.711	.813
H	.0030	.0050	.076	.127
J	.0030	.0050	.076	.127
K	.0209	.0211	.531	.536
L	.0080	.0100	.203	.254
M	.0104	.0106	.264	.269
N	.0059	.0061	.150	.155

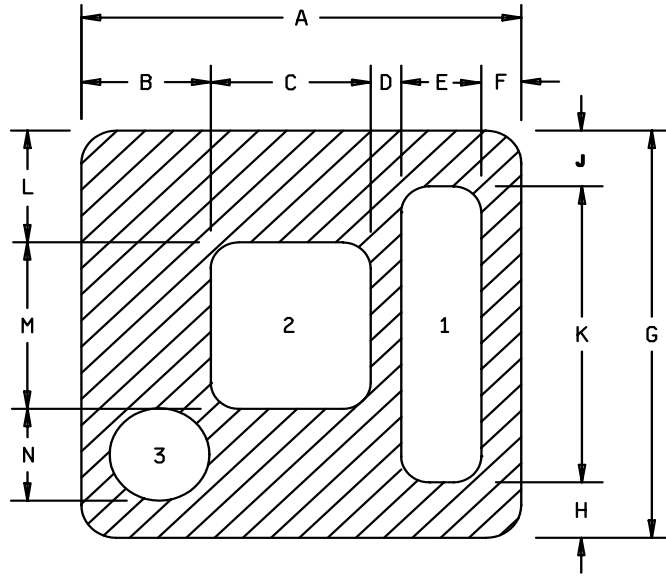

Backside must be electrically isolated to ensure proper performance.

Design data

Metallization:

Top: 1 (Cathode) Al
 2 (Anode) Al
 3 (Test pad) Al

Circuit layout data:
 For zener operation, cathode must be operated positive with respect to anode.
 Test pad is for wire bond evaluation only.
 No electrical contact is made with test pad.

Back: Au

Al thickness 25,000Å minimum.
 Gold thickness 4,000Å minimum.
 Chip thickness 0.010 inch (0.25 mm) ±0.002 inch (0.05 mm).

NOTES:

1. Dimensions are in inches unless otherwise indicated.
2. Millimeters are given for general information only.

* FIGURE 3. JANHC and JANKC (A-version) die dimensions.

MIL-PRF-19500/452G

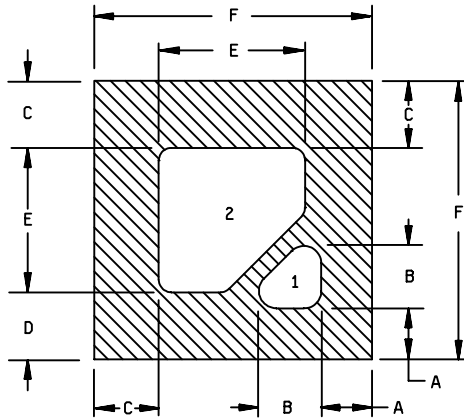

BACKSIDE MUST BE ELECTRICALLY ISOLATED

Symbol	Dimensions			
	Inches		Millimeters	
	Min	Max	Min	Max
A	.0035	.0065	.088	.165
B	.0050	.0080	.127	.200
C	.0050	.0065	.127	.165
D	.0050	.0065	.127	.165
E	.0150	.0165	.381	.419
F	.0260	.0290	.660	.737

Design data

Metallization:

Top: 1. (Cathode) Al
 2. (Anode) Al
 Back: Au

Circuit layout data:

For zener operation, cathode must be operated positive with respect to anode.

Al thickness 40,000Å minimum.

Gold thickness 5,000Å minimum.

Chip thickness010 inch (0.25 mm) ±0.002 inch (0.05 mm).

NOTES:

1. Dimensions are in inches.
2. Millimeters are given for general information.

* FIGURE 4. JANHC and JANKC (B-version) die dimensions.

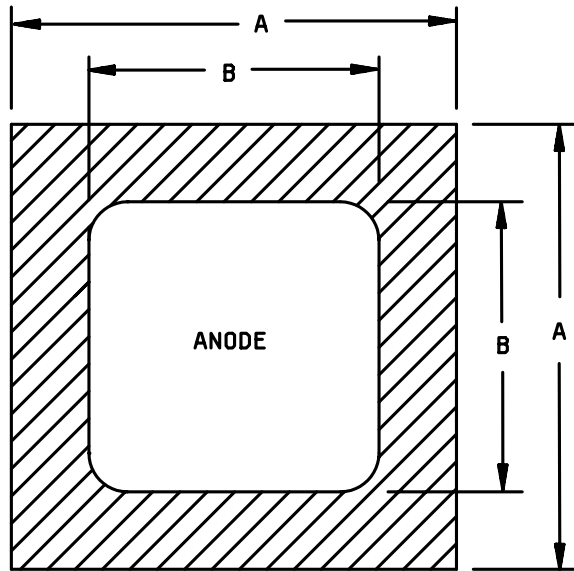

BACKSIDE IS CATHODE

Dimensions				
Symbol	Inches		Millimeters	
	Min	Max	Min	Max
A	.024	.037	0.61	0.94
B	.014	.029	0.36	0.74

Design data

Metallization:

Top: (Anode) Al
 Back: (Cathode) Au

Circuit layout data:

For zener operation, cathode must be operated positive with respect to anode.
 Al thickness 40,000Å minimum.
 Gold thickness 5,000Å minimum.
 Chip thickness010 inch (0.25 mm) ±0.002 inch (0.05 mm).

NOTES:

1. Dimensions are in inches.
2. Millimeters are given for general information.

* FIGURE 5. JANHC and JANKC (C-version) die dimensions.

3.4.3 Dash-one construction. Shall be as specified in MIL-PRF-19500.

3.4.4 JANS construction. Construction shall be dash-one, category I or II metallurgical bond in accordance with MIL-PRF-19500.

3.4.5 JANHC and JANKC construction. JANHC and JANKC construction may differ in die size and bonding pad layout provided the manufacturing technology is identical (example: Diffused junction, alloy junction).

3.4.6 Package outline. This specification contains two standard packages; DO-7 and DO-35. Any user of this specification that has a specific package outline requirement shall specify their preference in the document order. If package is not specified, the manufacturer may supply either package (see 6.2).

3.5 Marking. Devices shall be marked as specified in MIL-PRF-19500.

3.6 Electrical performance characteristics. Unless otherwise specified herein, the electrical performance characteristics are as specified in 1.3, 1.4, and table I.

3.7 Electrical test requirements. The electrical test requirements shall be the subgroups specified in 4.4.2 and 4.4.3.

3.8 Workmanship. Semiconductor devices shall be processed in such a manner as to be uniform in quality and shall be free from other defects that will affect life, serviceability, or appearance.

4. VERIFICATION

4.1 Classification of inspections. The inspection requirements specified herein are classified as follows:

- a. Qualification inspection (see 4.2).
- b. Screening (see 4.3).
- c. Conformance inspection (see 4.4).

4.1.1 Sampling inspection. Sampling inspection shall be in accordance with MIL-PRF-19500 and as specified herein, except that lot accumulation period shall be 3 months in lieu of 6 weeks.

4.2 Qualification inspection. Qualification inspection shall be in accordance with MIL-PRF-19500 and as specified herein.

4.2.1 Group E inspection. Group E inspection shall be conducted in accordance with MIL-PRF-19500 and 4.4.5 herein.

4.2.2 JANHC and JANKC devices. Qualification for JANHC and JANKC devices shall be in accordance with MIL-PRF-19500.

4.2.3 Radiation hardened devices. See MIL-PRF-19500 and 4.4.4 herein.

MIL-PRF-19500/452G

* 4.3 Screening (JANS, JANTXV and JANTX levels only). Screening shall be in accordance with table IV of MIL-PRF-19500, appendix E and as specified herein. Specified electrical measurements shall be made in accordance with table I herein. Devices that exceed the limits of table I herein shall not be acceptable.

Screen (see appendix E, table IV of MIL-PRF-19500)	JANS level	JANTXV and JANTX level
1a	Required	Not required
1b	Required	Required (JANTXV only)
2	Not required	Not required
3a	Required	Required
3b	Not applicable	Not applicable
3c	Not applicable	Not applicable
4	Not applicable	Not applicable
5	Not applicable	Not applicable
6	Not applicable	Not applicable
7a	Not applicable	Not applicable
7b	Optional	Optional
8	Required	Not required
9	Required	Not applicable
10	Required	Not applicable
11	Required V_z, Z_z	Required V_z, Z_z
12	Required, see 4.3.1	Required, see 4.3.1
13	Required Subgroups 2 and 3 of table I herein; $\Delta Z_z \leq \pm 15$ percent of initial reading $\Delta V_z \leq \pm 0.005$ V dc from initial value at $T_A = +25^\circ\text{C} \pm 2^\circ\text{C}$	Required Subgroup 2 of table I herein $\Delta Z_z \leq \pm 15$ percent of initial reading. $\Delta V_z \leq \pm 0.005$ V dc from initial value at $T_A = +25^\circ\text{C} \pm 2^\circ\text{C}$
14a	Not applicable	Not applicable
14b	Required (1) (2)	Required (1) (2)
15	Required	Not required
16	Required	Not required

(1) See MIL-PRF-19500.

(2) For clear glass diodes, the hermetic seal (gross leak) may be performed at any time after temperature cycling.

4.3.1 Power burn-in conditions. Power burn-in conditions are as follows:

- a. 1N4565 through 1N4569: $I_Z = 0.5 \text{ mA dc} \pm 0.05 \text{ mA dc}$, $T_A = +150 +5^\circ\text{C}$, -0°C .
- b. 1N4570 through 1N4574: $I_Z = 1.0 \text{ mA dc} \pm 0.1 \text{ mA dc}$, $T_A = +150 +5^\circ\text{C}$, -0°C .
- c. 1N4575 through 1N4579: $I_Z = 2.0 \text{ mA dc} \pm 0.2 \text{ mA dc}$, $T_A = +150 +5^\circ\text{C}$, -0°C .
- d. 1N4580 through 1N4584: $I_Z = 4.0 \text{ mA dc} \pm 0.4 \text{ mA dc}$, $T_A = +150 +5^\circ\text{C}$, -0°C .

To better utilize burn-in equipment, higher values of I_Z shall be permitted provided the junction temperature does not exceed $+175^\circ\text{C}$.

4.3.2 Screening (JANHC and JANKC). Screening of JANHC and JANKC die shall be in accordance with MIL-PRF-19500.

4.4 Conformance inspection. Conformance inspection shall be in accordance with MIL-PRF-19500 and herein.

4.4.1 Group A inspection. Group A inspection shall be conducted in accordance with MIL-PRF-19500 and table I herein.

4.4.2 Group B inspection. Group B inspection shall be conducted in accordance with the conditions specified for subgroup testing in appendix E, tables VIa (JANS) and VIb (JAN, JANTX, JANTXV,) of MIL-PRF-19500. Electrical measurements (end-points) shall be in accordance with the applicable steps of table I, subgroup 2 herein.

* 4.4.2.1 Group B inspection, appendix E, table VIa (JANS) of MIL-PRF-19500. For purposes of JANS inspection, a single device type shall be defined as devices from a single wafer lot (for each die type used in the construction). The conformance inspection sample shall be selected from the part category with the lowest ΔV_Z rating in the inspection lot.

<u>Subgroup</u>	<u>Method</u>	<u>Conditions</u>
B1	2066	As specified.
B2	2026	As specified.
B2	1022	As specified.
B3	1056	Test condition A, 25 cycles.
B3	4066	Not applicable.
B3	1071	Test condition E.
B3	2075	As specified.
B4	1037	$I_Z = 35 \text{ mA dc}$ at $T_A = \text{room ambient}$; $t_{on} = t_{off} = 30 \text{ seconds}$ minimum for 4,000 cycles.
B5	1027	$I_{ZM} = 70 \text{ mA dc}$ for 96 hours. $T_A = +75^\circ\text{C}$ or adjusted as required, to give an average lot $T_J = +200^\circ\text{C}$.
B6		Not applicable.

* 4.4.2.2 Group B inspection, appendix E, table VIb (JAN, JANTX, JANTXV,) of MIL-PRF-19500.

<u>Subgroup</u>	<u>Method</u>	<u>Conditions</u>
B1	2026	As specified.
B1	1022	As specified.
B2	1056	Test condition A, 25 cycles.
B2	4066	Not applicable.
B2	1071	Test condition E.
B3	1027	Conditions for " A-1 and AUR-1" versions: (see 4.3.1).
B4	2075	As specified.
B5		Not applicable.
B6	1032	As specified.

4.4.3 Group C inspection. Group C inspection shall be conducted in accordance with the conditions specified for subgroup testing in appendix E, table VII of MIL-PRF-19500. Electrical measurements (end-points) requirements shall be in accordance with the applicable steps of table I, subgroup 2 herein.

* 4.4.3.1 Group C inspection, appendix E, table VII of MIL-PRF-19500.

<u>Subgroup</u>	<u>Method</u>	<u>Conditions</u>
C1	2066	As specified.
C2	1056	Test condition A, 25 cycles.
C2	2036	Tension: Test condition A; 4 pounds weight, t = 15 ±3 seconds; Lead fatigue: Test condition E (lead fatigue and tension tests are not applicable to surface mount "UR" version devices).
C2	1071	Test condition E.
C2	1021	Omit initial conditioning.
C3		Not applicable.
C4	1041	As specified.
C5		Not applicable.
C6	1026	Conditions for " A-1 and AUR-1" versions of: 1N4565 through 1N4569: $I_Z = 0.5 \text{ mA dc}$, $T_A = +100^\circ\text{C}$ (see 4.5.2). 1N4570 through 1N4574: $I_Z = 1.0 \text{ mA dc}$, $T_A = +100^\circ\text{C}$ (see 4.5.2). 1N4575 through 1N4579: $I_Z = 2.0 \text{ mA dc}$, $T_A = +100^\circ\text{C}$ (see 4.5.2). 1N4580 through 1N4584: $I_Z = 4.0 \text{ mA dc}$, $T_A = +100^\circ\text{C}$ (see 4.5.2).
C7		Not applicable.

* 4.4.4 Group D inspection. Group D inspection shall be conducted in accordance with appendix E, table VIII of MIL-PRF-19500 and table II herein. Submitted lots for group D sample inspection must be constructed using one homogeneous wafer lot for the zener and one wafer lot for the compensating die (die), as also described in the submitted DSCC Design and Construction form 36D (see table II herein).

4.4.5 Group E inspection. Group E inspection shall be conducted in accordance with the conditions specified for subgroup tests in appendix E, table IX of MIL-PRF-19500 and table III herein.

4.5 Methods of inspection. Methods of inspection shall be as specified in the appropriate tables as follows.

4.5.1 Voltage temperature stability. The breakdown voltage of each type shall be measured and recorded at each of the specified temperatures. The lowest measured voltage shall be subtracted from the highest measured voltage for each diode. The difference value obtained shall not exceed the specified ΔV_z per diode type.

4.5.2 Reference voltage time stability. The breakdown voltage shall be measured prior to life testing, at 340 hours, and at the conclusion of the life test. The 340-hour reading shall be compared with the 0-hour reading and the 1,000-hour reading compared with the 340-hour reading. The change in breakdown voltage shall not exceed the limits specified. The test temperature for breakdown voltage shall be the same as the specified ambient life test temperature (see table IV herein).

4.5.3 Reference voltage. The test current shall be applied until thermal equilibrium is attained (15 s maximum) prior to reading the reference voltage. For this test, the diode shall be suspended by its' leads with mounting clips whose inside edge is located at .375 inch (9.53 mm) from the body and the mounting clips shall be maintained at the specified temperature. This measurement may be performed after a shorter time following application of the test current than that which provide thermal equilibrium if correlation to stabilized readings can be established to the satisfaction of the Government.

MIL-PRF-19500/452G

TABLE I. Group A inspection.

Inspection <u>1/</u>	MIL-STD-750		Symbol	Limits		Unit
	Method	Conditions		Min	Max	
<u>Subgroup 1</u>						
Visual and mechanical examination	2071					
<u>Subgroup 2 2/</u>						
Reference voltage	4022	See 4.5.3	V _Z	6.08	6.72	V dc
1N4565 through 1N4569 1N4570 through 1N4574 1N4575 through 1N4579 1N4580 through 1N4584		I _Z = 0.5 ±0.01 mA dc I _Z = 1.0 ±0.01 mA dc I _Z = 2.0 ±0.01 mA dc I _Z = 4.0 ±0.01 mA dc				
Small signal breakdown impedance	4051		Z _Z			ohms
1N4565 through 1N4569		I _Z = 0.5 ±0.01 mA dc, I _{sig} = 0.05 mA rms			200	
1N4570 through 1N4574		I _Z = 1.0 ±0.01 mA dc, I _{sig} = 0.1 mA rms			100	
1N4575 through 1N4579		I _Z = 2.0 ±0.01 mA dc, I _{sig} = 0.2 mA rms			50	
1N4580 through 1N4584		I _Z = 4.0 ±0.01 mA dc, I _{sig} = 0.4 mA rms			25	
<u>Subgroup 3</u>						
Voltage-temperature stability (see 4.5.1 and 4.5.3)		T _A = -55°C, 0°C, +25°C, +75°C, +100°C ±2°C, I _Z = (see 1.4)	ΔV _Z			mV dc
1N4565A-1, 1N4565AUR-1					100	
1N4570A-1, 1N4570AUR-1					100	
1N4575A-1, 1N4575AUR-1					100	
1N4580A-1, 1N4580AUR-1					100	
1N4566A-1, 1N4566AUR-1					50	
1N4571A-1, 1N4571AUR-1					50	
1N4576A-1, 1N4576AUR-1					50	
1N4581A-1, 1N4581AUR-1					50	

See footnotes at end of table.

MIL-PRF-19500/452G

TABLE I. Group A inspection - Continued.

Inspection <u>1/</u>	MIL-STD-750		Symbol	Limits		Unit
	Method	Conditions		Min	Max	
<u>Subgroup 3</u> – Continued 1N4567A-1, 1N4567AUR-1 1N4572A-1, 1N4572AUR-1 1N4577A-1, 1N4577AUR-1 1N4582A-1, 1N4582AUR-1 1N4568A-1, 1N4568AUR-1 1N4573A-1, 1N4573AUR-1 1N4578A-1, 1N4578AUR-1 1N4583A-1, 1N4583AUR-1 1N4569A-1, 1N4569AUR-1 1N4574A-1, 1N4574AUR-1 1N4579A-1, 1N4579AUR-1 1N4584A-1, 1N4584AUR-1 <u>Subgroups 4, 5, and 6</u> Not applicable <u>Subgroup 7</u>						mV dc
Reverse leakage current	4016	DC method; $V_R = 3.0V$	I_R		2.0	μA

1/ For sampling plan, see MIL-PRF-19500.

2/ Electrical characteristics apply to all package styles.

MIL-PRF-19500/452G

TABLE II. Group D inspection.

Inspection <u>1/ 2/</u>	MIL-STD-750		Symbol	JANTXV and JANS Pre-irradiation limits		JANTXV and JANS Post-irradiation limits		ΔV_{Z0} Pre-post		Unit
	Method	Conditions		M, D, L, R, F, G, and H		M, D, L, R, F, G, and H		IRRAD change		
				Min	Max	Min	Max	Min	Max	
<u>Subgroup 1</u> Not applicable										
<u>Subgroup 2</u> Steady-state total dose irradiation	1019	$T_C = +25^\circ\text{C}$ $I_Z = (\text{see } 1.4)$ condition A								
Reference voltage (see 4.5.3)	4022	$I_Z = (\text{see } 1.4)$	V_Z	6.08	6.72	6.08	6.72			V dc
Small-signal breakdown impedance	4051	$I_Z = (\text{see } 1.4)$	Z_Z							ohms
1N4565		$I_{sig} = 0.05 \text{ mA ac}$			200		200			
1N4566		$I_{sig} = 0.05 \text{ mA ac}$			200		200			
1N4567		$I_{sig} = 0.05 \text{ mA ac}$			200		200			
1N4568		$I_{sig} = 0.05 \text{ mA ac}$			200		200			
1N4569		$I_{sig} = 0.05 \text{ mA ac}$			200		200			
1N4570		$I_{sig} = 0.1 \text{ mA ac}$			100		100			
1N4571		$I_{sig} = 0.1 \text{ mA ac}$			100		100			
1N4572		$I_{sig} = 0.1 \text{ mA ac}$			100		100			
1N4573		$I_{sig} = 0.1 \text{ mA ac}$			100		100			
1N4574		$I_{sig} = 0.1 \text{ mA ac}$			100		100			
1N4575		$I_{sig} = 0.2 \text{ mA ac}$			50		50			
1N4576		$I_{sig} = 0.2 \text{ mA ac}$			50		50			
1N4577		$I_{sig} = 0.2 \text{ mA ac}$			50		50			
1N4578		$I_{sig} = 0.2 \text{ mA ac}$			50		50			
1N4579		$I_{sig} = 0.2 \text{ mA ac}$			50		50			
1N4580		$I_{sig} = 0.4 \text{ mA ac}$			25		25			
1N4581		$I_{sig} = 0.4 \text{ mA ac}$			25		25			
1N4582		$I_{sig} = 0.4 \text{ mA ac}$			25		25			
1N4583		$I_{sig} = 0.4 \text{ mA ac}$			25		25			
1N4584		$I_{sig} = 0.4 \text{ mA ac}$			25		25			

See footnotes at end of table.

MIL-PRF-19500/452G

TABLE II. Group D inspection - Continued.

Inspection <u>1/</u> <u>2/</u>	MIL-STD-750		Symbol	JANTXV and JANS Pre-irradiation limits		JANTXV and JANS Post-irradiation limits		ΔV_{Z0} Pre-post		Unit
	Method	Conditions		M, D, L, R, F, G, and H		M, D, L, R, F, G, and H		I_{RRAD} change		
				Min	Max	Min	Max	Min	Max	
<u>Subgroup 2</u> - Continued.										
Reverse current leakage	4016	DC method; $V_R = 3.0$ V dc	I_R		2.0		2.0			μA
Voltage stability (see 4.5.1)	4022	$I_Z =$ (see 1.4) $T_A = +25^\circ C$ $\pm 2^\circ C$	ΔV_Z							mV
1N4565									± 3	
1N4566									± 3	
1N4567									± 2	
1N4568									± 1.5	
1N4569									± 1	
1N4570									± 3	
1N4571									± 3	
1N4572									± 2	
1N4573									± 1.5	
1N4574									± 1	
1N4575									± 3	
1N4576									± 3	
1N4577									± 2	
1N4578									± 1.5	
1N4579									± 1	
1N4580									± 3	
1N4581									± 3	
1N4582									± 2	
1N4583									± 1.5	
1N4584									± 1	

1/ For sampling plan, see MIL-PRF-19500.

2/ Electrical characteristics and test conditions for "A-1 and AUR-1" devices are identical.

MIL-PRF-19500/452G

* TABLE III. Group E inspection qualification and requalification (all product assurance levels).

Inspection	MIL-STD-750		Qualification conformance inspection (sampling plan)
	Method	Conditions	
<u>Subgroup 1</u>			22 devices, c = 0
Temperature cycling	1051	500 cycles.	
Electrical measurements		See table I, subgroup 2 herein.	
<u>Subgroup 2</u>			22 devices, c = 0
Steady state operation life	1038	Condition B, 1,000 hours. (see 4.3.1).	
Electrical measurements		See table I, subgroup 2 herein.	
<u>Subgroup 3</u>			3 devices, c = 0
Decap analysis	2101	Cross section and scribe and break. Separate samples shall be used for each test.	
<u>Subgroups 4, 5, 6, and 7</u>			
Not applicable			
<u>Subgroup 8</u>			45 devices
Resistance to glass cracking	1057	Step stress to destruction by increasing cycles or up to a maximum of 25 cycles.	

TABLE IV. Reference voltage time stability.

Step	Inspection	MIL-STD-750		Symbol	Limit		Unit
		Method	Condition		Min	Max	
1.	Reference-voltage stability		$T_A = +100^\circ\text{C} \pm 2^\circ\text{C}$ (0 to 340 hours, see 4.5.2 and 4.5.3)	ΔV_Z			
	1N4565, 1N4570 1N4575, 1N4580						10 10
	1N4566, 1N4571 1N4576, 1N4581						8 8
	1N4567, 1N4572 1N4577, 1N4582						7 7
	1N4568, 1N4573 1N4578, 1N4583						6 6
	1N4569, 1N4574 1N4579, 1N4584						5 5
2.	Reference-voltage stability		$T_A = +100^\circ\text{C} \pm 2^\circ\text{C}$ (340 to 1,000 hours, see 4.5.2 and 4.5.3)	ΔV_Z			
	1N4565, 1N4570 1N4575, 1N4580						5 5
	1N4566, 1N4571 1N4576, 1N4581						4 4
	1N4567, 1N4572 1N4577, 1N4582						4 4
	1N4568, 1N4573 1N4578, 1N4583						3 3
	1N4569, 1N4574 1N4579, 1N4584						3 3

5. PACKAGING

* 5.1 Packaging. For acquisition purposes, the packaging requirements shall be as specified in the contract or order (see 6.2). When actual packaging of materiel is to be performed by DoD or in-house contractor personnel, these personnel need to contact the responsible packaging activity to ascertain packaging requirements. Packaging requirements are maintained by the Inventory Control Point's packaging activities within the Military Service or Defense Agency, or within the Military Service's system commands. Packaging data retrieval is available from the managing Military Department's or Defense Agency's automated packaging files, CD-ROM products, or by contacting the responsible packaging activity.

6. NOTES

(This section contains information of a general or explanatory nature that may be helpful, but is not mandatory.)

6.1 Intended use. The notes specified in MIL-PRF-19500 are applicable to this specification.

* 6.2 Acquisition requirements. Acquisition documents should specify the following:

- a. Title, number, and date of this specification.
- b. Packaging requirements (see 5.1).
- c. Lead finish (see 3.4.1).
- d. Product assurance level and type designator.

6.3 Qualification. With respect to products requiring qualification, awards will be made only for products which are, at the time of award of contract, qualified for inclusion in Qualified Manufacturers List (QML 19500) whether or not such products have actually been so listed by that date. The attention of the contractors is called to these requirements, and manufacturers are urged to arrange to have the products that they propose to offer to the Federal Government tested for qualification in order that they may be eligible to be awarded contracts or orders for the products covered by this specification. Information pertaining to qualification of products may be obtained from Defense Supply Center, Columbus, ATTN: DSCC/VQE, P.O. Box 3990, Columbus, OH 43218-3990 or e-mail vqe.chief@dla.mil.

6.4 Suppliers of JANHC and JANKC die. The qualified JANHC and JANKC suppliers with the applicable letter version (example, JANHCAM1N4565A) will be identified on the parts list of MIL-PRF-19500.

JANC ordering information					
PIN	Manufacturer				
	43611	43611 Radiation designators M,D,L,R,F,G,H	12954	12954 Radiation designators M,D,L,R,F,G,H	12954
1N4565A through 1N4584A	JANHCA1N4565A through JANHCA1N4584A	JANHCA1N4565A through JANHCA1N4584A	JANHCB1N4565A through JANHCB1N4584A	JANHCB1N4565A through JANHCB1N4584A	JANHCC1N4565A through JANHCC1N4584A
1N4565A through 1N4584A	JANKCA1N4565A through JANKCA1N4584A	JANKCA1N4565A through JANKCA1N4584A	JANKCB1N4565A through JANKCB1N4584A	JANKCB1N4565A through JANKCB1N4584A	JANKCC1N4565A through JANKCC1N4584A

6.5 Substitution of radiation hardened devices. See MIL-PRF-19500.

6.6 Substitution of devices. ΔV_z Device types within this series with higher type numbers (lower ΔV_z) are a direct one way substitution for lower type numbers (higher ΔV_z).

6.7 Changes from previous issue. The margins of this specification are marked with asterisks to indicate where changes from the previous issue were made. This was done as a convenience only and the Government assumes no liability whatsoever for any inaccuracies in these notations. Bidders and contractors are cautioned to evaluate the requirements of this document based on the entire content irrespective of the marginal notations and relationship to the last previous issue.

Custodians:
 Army - CR
 Navy - EC
 Air Force - 11
 NASA - NA
 DLA - CC

Preparing activity:
 DLA - CC
 (Project 5961-2888)

Review activities:
 Army - AR, MI, SM
 Navy - AS, MC
 Air Force - 19, 99

* NOTE: The activities listed above were interested in this document as of the date of this document. Since organizations and responsibilities can change, you should verify the currency of the information above using the ASSIST Online database at <http://www.dodssp.daps.mil>.