

Bt860/861

Multiport YCrCb to NTSC/PAL/SECAM Digital Video Encoder

The Bt860/861 is a multiport digital video encoder with pixel synchronization and per-pixel blending capabilities. The three 8-bit YCrCb data ports allow for a variety of video and graphic overlay configurations useful in video set-top box applications.

The Bt860/861 is specifically designed for video systems requiring composite, Y/C (S-Video), and simultaneous component YUV or RGB (SCART) video signals. Worldwide video standards are supported, including NTSC-M (N. America, Taiwan, Japan), PAL-B,D,G,H,I (Europe, Asia), PAL-M (Brazil), PAL-N (Uruguay, Paraguay), PAL-Nc (Argentina), PAL-60, NTSC-443, and SECAM. The Bt860 and Bt861 are functionally identical except that the Bt861 can output the Macrovision 7.x anticopy algorithm.

Multisource video is a key feature of the Bt860/861. Two general purpose ports (P and OSD) allow synchronization with sources that can share clock and frame timing control with the Bt860/861, such as digital video and graphic overlay content generated by an MPEG video decoder. A third port (VID) is specifically configured to interface with video decoders such as those in the Conexant VideoStream decoder family. Any pair of these three ports can be synchronized and blended.

Functional Block Diagram

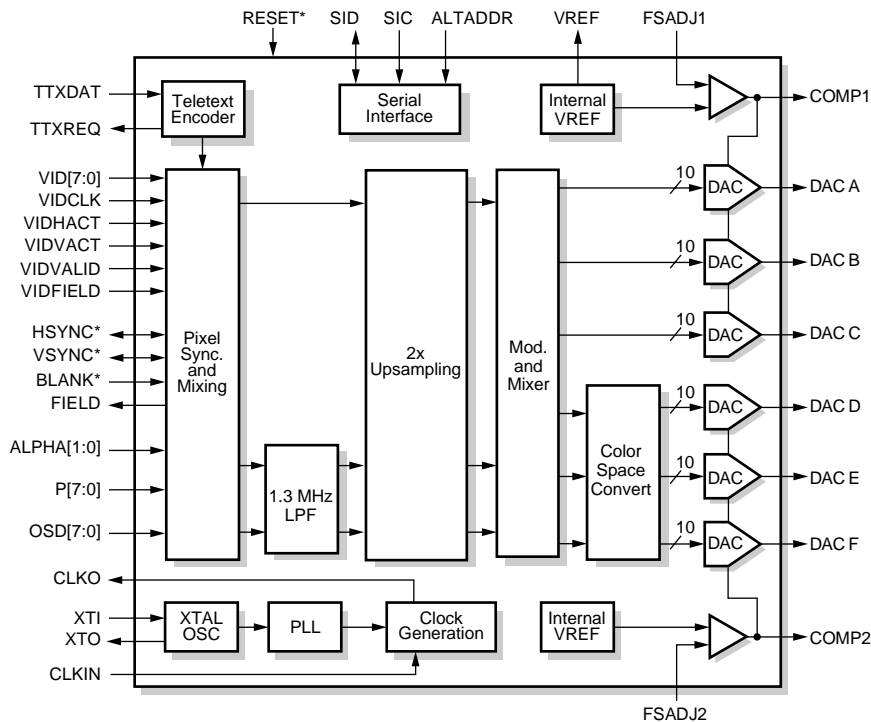

Distinguishing Features

- Six 10-bit DACs with individual power management
- Simultaneous output of YUV, S-Video, and CVBS, or RGB (SCART), S-Video, and CVBS
- Current drive output DACs for superior video quality and reduced system cost
- Dynamic video load sensing for reduced power operation
- Three sharpness filter options (1,2,3.5 dB gain) and four reduction filter options
- Programmable adjustment of brightness, contrast, color saturation, and hue
- Glueless interface with a video decoder
- Three 8-bit YCrCb 4:2:2 inputs for overlay or blending
- ITU-R BT.656, ITU-R BT.601 digital video input options
- NTSC-M, PAL (B,D,G,H,I), PAL-M, PAL-N, NTSC-443, PAL-Nc, PAL-60 and SECAM video output
- 2x upsampling and internal filtering for reduced cost
- Master or slave video timing with programmable HSYNC* delay
- Interlaced/noninterlaced operation
- Macrovision 7.x copy protection (Bt861)
- Closed Captioning and Extended Data Services encoding
- Teletext encoding (WST system B)
- 400 kHz serial programming interface
- On-board voltage reference
- Reduced power modes
- Programmable luma delay (two channels)
- 3.3 V supply, 5 V-tolerant inputs
- Copy Generation Management System (CGMS) support
- VARIS-II and Wide Screen Signalling (WSS) multiple aspect ratio support
- Internal color bar generation
- Blue field generation
- 80-pin MQFP package

Related Products

- Bt852, Bt868/869, Bt864A/865A, Bt866/867
- Bt835, Bt829A/B

Applications

- Digital cable television systems
- Satellite TV receivers (DBS/DVB/DSS)
- DVD players
- Video CD players
- Digital cameras
- PC add-on cards
- Video editing

Ordering Information

Model Number	Package	Operating Temperature
Bt860KRF	80-Pin MQFP	0 °C–70 °C
Bt861KRF	80-Pin MQFP	0 °C–70 °C

Information provided by Conexant Systems, Inc. (Conexant) is believed to be accurate and reliable. However, no responsibility is assumed by Conexant for its use, nor any infringement of patents or other rights of third parties which may result from its use. No license is granted by implication or otherwise under any patent rights of Conexant other than for circuitry embodied in Conexant products. Conexant reserves the right to change circuitry at any time without notice. This document is subject to change without notice.

Conexant products are not designed or intended for use in life support appliances, devices, or systems where malfunction of a Conexant product can reasonably be expected to result in personal injury or death. Conexant customers using or selling Conexant products for use in such applications do so at their own risk and agree to fully indemnify Conexant for any damages resulting from such improper use or sale.

Conexant and “What’s Next in Communications Technologies” are trademarks of Conexant Systems, Inc.

This device is protected by U.S. patent numbers 4,631,603, 4,577,216, and 4,819,098, and other intellectual property rights. The use of Macrovision’s copy protection technology in the device must be authorized by Macrovision and is intended for home and other limited pay-per-view uses only, unless otherwise authorized in writing by Macrovision. Reverse engineering or disassembly is prohibited.

Product names or services listed in this publication are for identification purposes only, and may be trademarks or registered trademarks of their respective companies. All other marks mentioned herein are the property of their respective holders.

© 1999 Conexant Systems, Inc.
Printed in U.S.A.
All Rights Reserved

Reader Response: To improve the quality of our publications, we welcome your feedback. Please send comments or suggestions via e-mail to Conexant Reader Response@conexant.com. Sorry, we can't answer your technical questions at this address. Please contact your local Conexant [sales office](#) (listed on back page) or applications engineer if you have technical questions.

Table of Contents

List of Figures	vii
List of Tables	ix
1.0 Functional Description	1-1
1.1 Pin Descriptions	1-1
1.2 Functional Overview	1-5
2.0 Inputs and Timing	2-1
2.1 Reset	2-1
2.1.1 Initialization and Power-up Configuration	2-1
2.2 Digital Video Ports	2-2
2.2.1 The P Port	2-3
2.2.2 The VID Port	2-3
2.2.3 The OSD Port	2-3
2.2.4 Overlay Modes and Alpha Blending	2-4
2.2.5 Alpha Pin Blending	2-5
2.2.6 Content-based Blending	2-5
2.3 Configurations and Timing	2-6
2.3.1 ITU-R BT.601 Configurations and Timing	2-7
2.3.2 ITU-R BT.656 Timing	2-10
2.3.3 VID Port (Video Decoder Locked) Timing	2-12
2.4 Clock Selection	2-14
2.4.1 Crystal Inputs and the PLL	2-14

3.0	Digital Processing and Functionality	3-1
3.1	Video	3-1
3.1.1	Video Standards	3-1
3.1.2	Analog Horizontal Sync	3-9
3.1.3	Analog and Digital Vertical Sync	3-9
3.1.4	Analog Video Blanking	3-10
3.1.5	Subcarrier and Burst Generation	3-11
3.1.6	Subcarrier Phasing (SC_H Phase)	3-12
3.1.7	Noninterlaced Operation	3-12
3.2	Effects	3-13
3.2.1	Chrominance Disable	3-13
3.2.2	Internal Filtering	3-13
3.2.3	Internal Colorbars, Blue Field, and Black Burst	3-15
3.2.4	Setup	3-19
3.2.5	YUV and RGB Multipliers	3-19
3.2.6	Programming Values to Comply with YPrPb and RGB	3-19
3.2.7	Programmable Video Adjustments Controls	3-20
3.2.7.1	Hue Adjust	3-20
3.2.7.2	Brightness Adjust	3-20
3.2.7.3	Contrast Adjust	3-21
3.2.7.4	Saturation Adjust	3-21
3.2.7.5	Sharpness Adjust	3-21
3.2.8	Macrovision Encoding (Bt861 Only)	3-22
3.2.9	Outputs	3-22
3.2.10	Luminance Delay	3-22
3.2.11	Special SCART Signals	3-23
3.2.12	Output Connection Status	3-23
3.2.13	Output Filtering and SINX/X Compensation	3-24
3.2.14	Low Power Features	3-24
3.2.15	Teletext Operation of Bt860/861	3-25
3.2.15.1	Teletext Timing Mode 1	3-26
3.2.15.2	Teletext Timing Mode 2	3-26
3.2.15.3	General Teletext Operation	3-27
3.2.16	Wide Screen Signaling	3-27
3.2.17	Copy Generation Management System	3-28
3.2.18	Closed Captioning and Extended Data Services	3-29
3.2.18.1	Closed Captioning Pass-through	3-30

4.0	Applications	4-1
4.1	PC Board Considerations	4-1
4.1.1	Component Placement	4-1
4.1.2	Power and Ground Planes	4-1
4.1.3	Device Decoupling	4-3
4.1.4	Power Supply Decoupling	4-3
4.1.5	COMP Decoupling	4-4
4.1.6	VREF Decoupling	4-4
4.1.7	VBIAS Decoupling	4-4
4.1.8	Digital Signal Interconnect	4-5
4.1.9	Analog Signal Interconnect	4-5
4.1.10	ESD and Latchup Considerations	4-5
5.0	Serial Programming Interface and Registers	5-1
5.1	Serial Interface	5-1
5.1.1	Device Address	5-2
5.1.2	Writing Data	5-2
5.1.3	Reading Data	5-3
5.2	Internal Registers	5-4
5.2.1	Register Bit Map	5-4
5.3	Register Index	5-8
5.4	Register Detail	5-13
6.0	Parametric Data and Specifications	6-1
6.1	Electrical Specifications	6-1
6.1.1	Electrical Parameters	6-1
6.2	Mechanical Drawing	6-5

List of Figures

Figure 1-1.	Pinout Diagram	1-1
Figure 1-2.	Detailed Block Diagram	1-6
Figure 2-1.	Pixel Latching and Blending Mechanism	2-2
Figure 2-2.	Alpha Blending Timing Diagram	2-5
Figure 2-3.	Timing Mode 1 Connection Example	2-7
Figure 2-4.	Timing Mode 2 Connection Example	2-8
Figure 2-5.	Pixel Timing for Timing Modes 1 and 2	2-9
Figure 2-6.	Timing Mode 3 and 4 Connection Example	2-10
Figure 2-7.	625 Line ITU-R BT.656 Timing	2-11
Figure 2-8.	525 Line ITU-R BT.656 Timing	2-11
Figure 2-9.	Video Decoder Connection Example	2-13
Figure 2-10.	Timing and Clock Block Diagram	2-14
Figure 3-1.	NTSC Vertical Timing	3-9
Figure 3-2.	PAL Vertical Timing	3-10
Figure 3-3.	Luminance Upsampling Filter	3-13
Figure 3-4.	Luminance Upsampling Filter with Peaking and Reduction Options	3-13
Figure 3-5.	Close-Up of Luminance Upsampling Filter with Peaking and Reduction Options	3-14
Figure 3-6.	Luminance Reduction Filters Options	3-14
Figure 3-7.	Luminance Peaking Filter Options	3-14
Figure 3-8.	Chrominance Filter	3-14
Figure 3-9.	Chrominance Wide Bandwidth Filter	3-14
Figure 3-10.	SECAM High Frequency Pre-emphasis Filter	3-14
Figure 3-11.	SECAM Low Frequency Pre-emphasis Filter	3-15
Figure 3-12.	YUV Video Format (Internal Colorbars)	3-16
Figure 3-13.	RGB Video Format (Internal Colorbars)	3-17
Figure 3-14.	Composite and S-Video Format (Internal Colorbars)	3-18
Figure 3-15.	SCART Function on ALTADDR Pin	3-23
Figure 3-16.	Teletext Timing	3-25
Figure 3-17.	P:Q Ratio Counter Block Diagram	3-26
Figure 3-18.	WSS Waveform	3-28
Figure 3-19.	CGMS Waveform	3-29
Figure 3-20.	Closed Captioning or Extended Data Service Waveform (Null Sequence)	3-30
Figure 4-1.	Typical Connection Diagram	4-2
Figure 4-2.	Recommended Crystal Circuit	4-3
Figure 5-1.	Serial Programming Interface Timing Diagram	5-1
Figure 5-2.	Serial Programming Interface Typical Write Sequence	5-3
Figure 5-3.	Serial Programming Interface Typical Read Sequence	5-3
Figure 6-1.	Pixel and Control Data Timing Diagram	6-3
Figure 6-2.	80 MQFP Package Diagram	6-5

List of Tables

Table 1-1.	Pin Assignments	1-2
Table 2-1.	Alpha Blending Configurations	2-4
Table 2-2.	Configurable Timing States	2-6
Table 3-1.	Target Video Parameters	3-2
Table 3-2.	Register Programming Values for NTSC and PAL Video Standards (ITU-R BT.601)	3-4
Table 3-3.	Register Programming Values for NTSC and PAL Video Standards (Square Pixel)	3-6
Table 3-4.	Register Programming Values for SECAM	3-8
Table 3-5.	100/0/75/0 Colorbars as Described in EIA-770.1. EIA-770.1	3-16
Table 3-6.	100/0/75/0 Colorbars for a 625-Line System	3-17
Table 3-7.	Composite and Luminance Amplitude	3-18
Table 3-8.	Composite and Chrominance Magnitude	3-19
Table 3-9.	DAC Format Options	3-22
Table 3-10.	P:Q Ratio Counter Values	3-26
Table 3-11.	Teletext Line Disable	3-27
Table 3-12.	Closed Captioning and Extended Data Services Control Bits	3-29
Table 4-1.	Typical Parts List	4-4
Table 5-1.	Serial Address Configuration	5-2
Table 5-2.	Register Bit Map	5-4
Table 5-3.	Register Index	5-8
Table 6-1.	Absolute Maximum Ratings	6-1
Table 6-2.	DC Characteristics	6-2
Table 6-3.	AC Characteristics	6-3
Table 6-4.	Video Quality Specifications	6-4

1.0 Functional Description

1.1 Pin Descriptions

Figure 1-1. Pinout Diagram

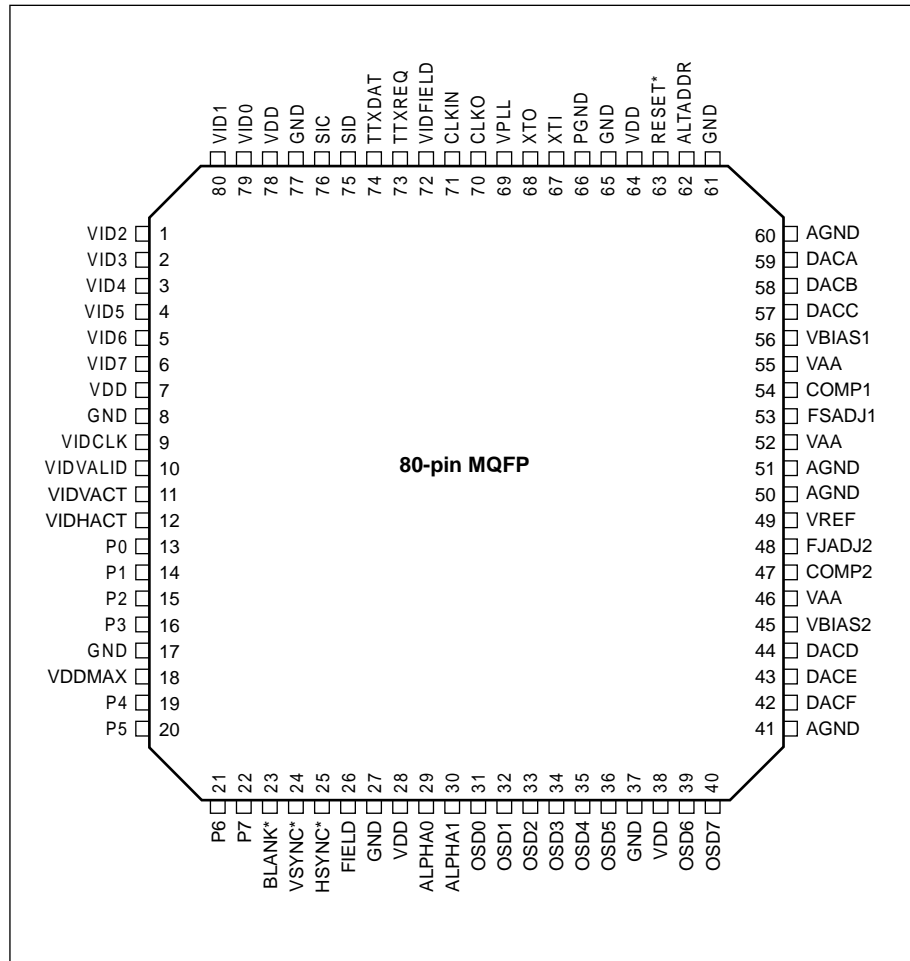

861_027

1.1 Pin Descriptions

Multiport YCrCb to NTSC/PAL/SECAM

Table 1-1. Pin Assignments (1 of 3)

Pin Name	I/O	Pin #	Description
PRIMARY VIDEO PORT			
P[7:0]	I	22-19, 16-13	Primary video input port (TTL compatible) ⁽¹⁾ . Accepts pixel data in 8-bit YCrCb 4:2:2 format in either ITU-R BT.601 or ITU-R BT.656 control formats. A higher index corresponds to a greater bit significance. By default, data is latched on the rising edge of the system clock ⁽²⁾ .
CLKO	O	70	2x pixel clock output. The clock generated by the PLL is produced at this pin when register bit CLKO_DIS = 0.
VSYNC*	I/O	24	Vertical sync input/output (TTL compatible). As an output (master mode operation), VSYNC* follows the rising edge of the system clock. As an input (slave mode operation), VSYNC* is, by default, registered on the rising edge of the system clock ⁽²⁾ . The VSYNCl register bit controls the polarity of this signal.
HSYNC*	I/O	25	Horizontal sync input/output (TTL compatible). As an output (master mode operation), HSYNC* follows the rising edge of the system clock. As an input (slave mode operation), HSYNC* is, by default, registered on the rising edge of the system clock ⁽²⁾ . The HSYNCl register bit controls the polarity of this signal.
BLANK*	I	23	Composite blanking control input (TTL compatible). By default, BLANK* is registered on the rising edge of the system clock ⁽²⁾ . The video data inputs are ignored while BLANK* is a logical 0. The BLANKI register bit controls the polarity of this signal.
FIELD	O	26	Field control output (TTL compatible). FIELD transitions after the rising edge of the system clock, two clock cycles following a falling HSYNC*. The FIELDI register bit controls the polarity of this signal. The state of this pin at power-up determines the default state of the PCLK_SEL register bit and the initial clock source. If not externally loaded, this pin will be pulled low with an internal pull-down resistor.
SECONDARY VIDEO PORT			
VID[7:0]	I	6-1, 80-79	Secondary video input port (TTL compatible). Accepts pixel data in 8-bit YCrCb 4:2:2 format. A higher index corresponds to a greater bit significance. By default, data on the VID port is latched by the rising edge of VIDCLK ^{(1) (3)} .
VIDCLK	I	9	Pixel clock for secondary video input port ⁽¹⁾ .
VIDHACT	I	12	Horizontal active display region. A logical 1 indicates data on VID[7:0] is in the horizontal display region. The VIDHACTI register bit controls the polarity of this signal. By default, data on VIDHACT is latched by the rising edge of VIDCLK ^{(1) (3)} .
VIDVACT	I	11	Vertical active display region. The VIDVACTI register bit controls the polarity of this signal. By default, data on VIDVACT is latched by the rising edge of VIDCLK ^{(1) (3)} .
VIDFIELD	I	72	Field indicator for video input port. A logical 1 indicates data is from an even field. The VIDFIELDI register bit controls the polarity of this signal. By default, data on VIDFIELD is latched by the rising edge of VIDCLK ^{(1) (3)} .
VIDVALID	I	10	Video data valid qualifier. A logical 1 indicates data on VID[7:0] is valid data. The VIDVALIDI register bit controls the polarity of this signal. By default, data on VIDVALID is latched by the rising edge of VIDCLK ^{(1) (3)} .

Table 1-1. Pin Assignments (2 of 3)

Pin Name	I/O	Pin #	Description
GRAPHIC AND BLENDING PINS			
OSD[7:0]	I	40-39, 36-31	Dedicated graphic overlay port (TTL compatible.) Accepts pixel data in 8-bit YCrCb 4:2:2 format. Data is latched on the rising edge of the system clock ^{(1) (2)} .
ALPHA[1:0]	I	30-29	Alpha blend pins. Provides for 1-, 2-, or 4-bit external blend selection between video and graphic overlay data. Data is latched on the rising edge of the system clock ^{(1) (2)} .
TELETEXT AND SERIAL CONTROL INTERFACE			
TTXDAT	I	74	Teletext data input (TTL compatible) ⁽¹⁾ .
TTXREQ	O	73	Teletext request output (TTL compatible).
ALTADDR	I/O	62	Alternate slave address input (TTL compatible). This pin is sampled immediately following a power-up or pin reset. A logical 1 corresponds to write address of 0x88 and a read address of 0x89, while a logical 0 corresponds to a write address of 0x8A and a read address of 0x8B. See Chapter 5.0 , for more detail. This pin also provides special SCART signals when register field SCART_SEL≠00.
SID	I/O	75	Serial programming interface data input/output (TTL compatible). Data is written to and read from the device via this serial bus.
SIC	I	76	Serial programming interface clock input (TTL compatible). The maximum clock rate is 400 kHz.
ANALOG VIDEO			
DACA	O	59	DAC A output. See Table 3-9 .
DACB	O	58	DAC B output. See Table 3-9 .
DACC	O	57	DAC C output. See Table 3-9 .
DACD	O	44	DAC D output. See Table 3-9 .
DACE	O	43	DAC E output. See Table 3-9 .
DACF	O	42	DAC F output. See Table 3-9 .
FSADJ1 FSADJ2	I	53 48	Full-scale adjust control pin. Resistors RSET1 and RSET2 connected between these pins and AGND control the full-scale output current of the DACs. For standard operation, use the nominal values shown under Recommended Operating Conditions. FSADJ1 controls DACs A/B/C and FSADJ2 controls DACs D/E/F.
VREF	O	49	Voltage reference pin. A 1.0 μF ceramic capacitor must be used to decouple this pin to AGND. The capacitor must be as close to the device as possible to keep lead lengths to an absolute minimum.
COMP1 COMP2	O	54 47	Compensation pin. A 0.1 μF ceramic capacitor must be used to decouple this pin to VAA. The capacitor must be as close to the device as possible to keep lead lengths to an absolute minimum.
VBIAS1 VBIAS2	O	56 45	DAC bias voltage. Use a 0.1 μF ceramic capacitor to bypass this pin to AGND; the capacitor must be as close to the device as possible to keep lead lengths to an absolute minimum.

Table 1-1. Pin Assignments (3 of 3)

Pin Name	I/O	Pin #	Description
SYSTEM PINS			
CLKIN	I	71	2x pixel clock input (TTL compatible).
RESET*	I	63	Reset control input (TTL compatible). Setting to zero resets video timing (horizontal, vertical, subcarrier counters to the start of VSYNC of first field), the serial control interface, and all registers. RESET* must be a logical 1 for normal operation. Holding this pin low for 50 clocks or more will ensure that all functions are properly reset.
XTI	I	67	Crystal input for PLL.
XTO	O	68	Crystal output for PLL.
POWER AND GROUND			
VAA	—	55, 46, 52	Analog power. See Section 4.1 of this document.
VDD	—	7, 28, 38, 64, 78	Digital power. See Section 4.1 of this document.
AGND	—	41, 50, 51, 60	Analog ground. See Section 4.1 of this document.
GND	—	8, 17, 27, 37, 61, 65, 77	Digital ground. See Section 4.1 of this document.
VPLL	—	69	Dedicated power supply for PLL.
PGND	—	66	Dedicated ground for PLL.
VDDMAX	I	18	This pin must be tied to the maximum digital input value. Use 3.3 V if only 3.3 V inputs are used, and 5 V if 3.3/5 V inputs are used.
<p>NOTE(S):</p> <p>(1) If these inputs are not used, they should be connected to GND.</p> <p>(2) These input are normally sampled on the rising edge of the system clock, but can be sampled on the falling edge by setting register bit PCLK_EDGE = 1.</p> <p>(3) These inputs are normally sampled on the rising edge of VIDCLK, but can be sampled on the falling edge by setting register bit VIDCLK_EDGE = 1.</p>			

1.2 Functional Overview

The Bt860/861 is a highly programmable 3.3 V multiport digital video encoder with pixel synchronization and per-pixel blending capabilities. It is equipped with three 8-bit YCrCb data ports that allow a variety of video and graphic overlay configurations useful in video set top box applications.

The three 8-bit YCrCb data ports allow two video streams and one alpha-blended overlay stream. For switching between video sources (such as a video decoder and an MPEG source), while providing a common OSD interface using the part's overlay and alpha capabilities.

The Bt860/861's VID port uses a PLL and FIFO to allow direct interfacing with asynchronous video sources, such as the Bt835 video decoder.

In slave mode, the Bt860/861 can be configured to accept either ITU-R BT.656-compliant timing (EAV and SAV codes) or ITU-R BT.601 data timing (HSYNC* and VSYNC* signals). The Bt860/861 can also act as timing master, producing ITU-R BT.601 timing.

The Bt860/861 supports worldwide video standards, including:

- NTSC-M (N. America, Taiwan, Japan)
- PAL-B, D, G, H, I (Europe, Asia)
- PAL-M (Brazil)
- PAL-N (Uruguay, Paraguay)
- PAL-Nc (Argentina)
- PAL-60, NTSC-443
- SECAM

The Bt860/861 has six 10-bit current-out video DACs, specifically designed for video systems requiring the generation of high quality composite, Y/C (S-Video), and simultaneous component YUV or RGB (SCART) video signals. Two of the composite output signals can be programmed with a 0–7 clock luminance delay. The connection status of each DAC can be dynamically monitored through the serial programming interface.

The Bt860/861 has several low power options, including sleep mode (only the serial programming interface and PLL are operational), individual DAC disable, PLL disable, and 3.3 V operation. The 3.3 V digital inputs can be configured to be 5 V-tolerant.

The luminance upsampling filter is enhanced to provide a narrow transition region and a low stopband. Programmable luminance sharpness filters provide 0, 1, 2, and 3.5 dB peaking options at higher video frequencies, and four reduction filters are added for smoothed step response. To reduce the complexity of the required reconstruction filter, 2x upsampling is implemented.

The Bt860/861 can produce internally generated colorbars and blue field signals.

A 400 kHz serial programming interface (I²C-compatible) is provided for fast system programming.

The Bt860/861 provides support for Closed Captioning (CC) and Extended Data Services (XDS), Teletext (WST system B), Copy Generation Management System (CGMS), VARIS-II, and Wide Screen Signaling (WSS).

The Bt860 and Bt861 are functionally identical except that the Bt861 can output the Macrovision 7.x anticopy algorithm.

Figure 1-2. Detailed Block Diagram

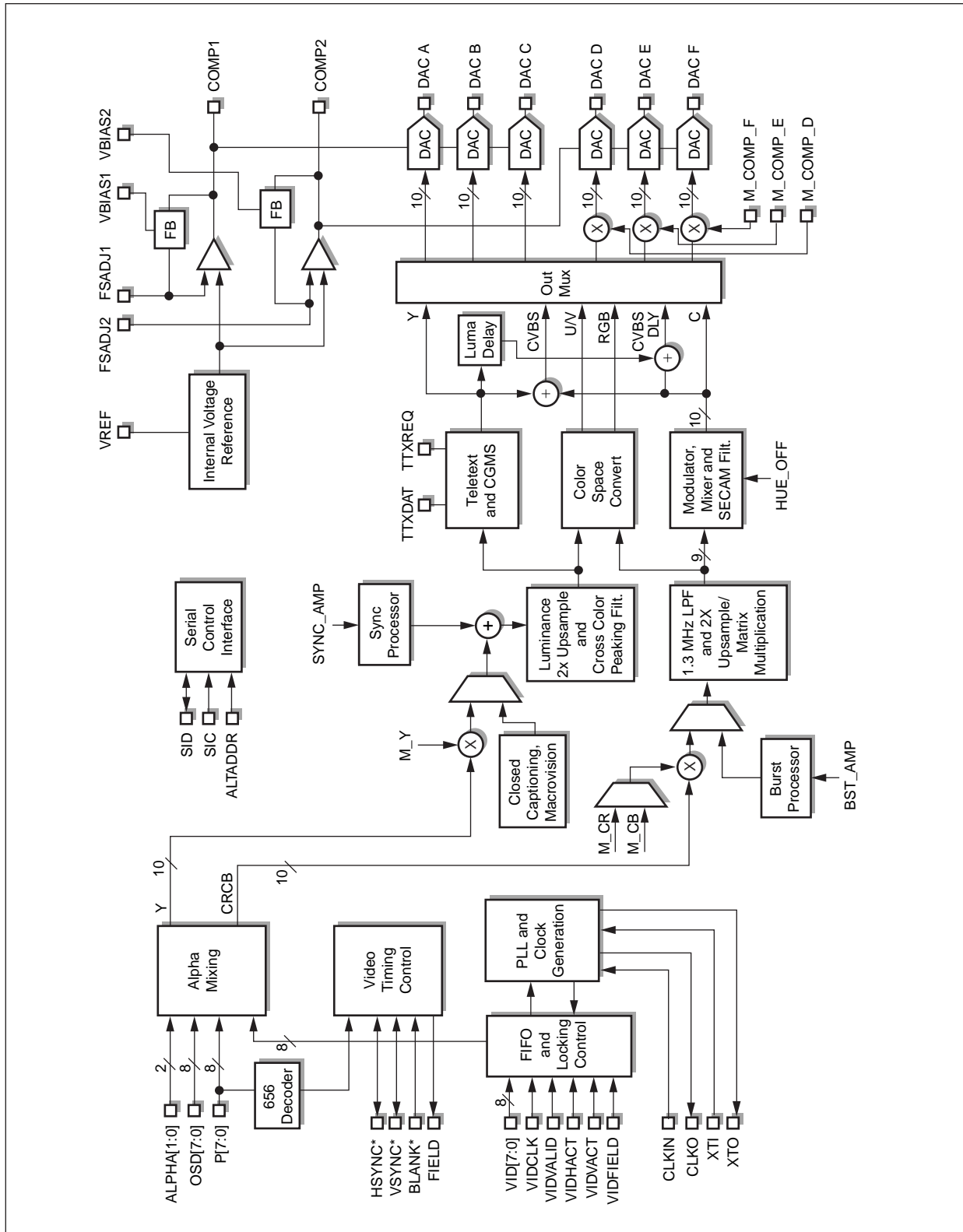

861_028

2.0 Inputs and Timing

2.1 Reset

The Bt860/Bt861 has the following reset methods:

- power-up reset
- RESET* pin reset
- software reset register bit

Power-up reset occurs when the part is powered-up. A pin reset occurs when the RESET* pin is held low. (It is recommended that the pin be held low for a minimum of 50 system clock cycles.) Both power-up and pin reset cause the initialization of all chip functions, including video timing and serial programming registers.

Writing a 1 to register bit SRESET (1B[7]) resets all serial programming registers to their default states, listed in [Section 5.0](#).

2.1.1 Initialization and Power-up Configuration

At power-up all registers reset to their initial values (see [Section 5.0](#)).

The state of the FIELD pin at power-up (or pin reset) determines the default state of the PCLK_SEL register bit and the initial clock source. If the FIELD pin is pulled high, the initial clock source is the CLKIN pin; if the FIELD pin is pulled low, the initial clock source is from the PLL and requires a crystal at the XTI and XTO pins. If not loaded, the FIELD pin is pulled low with the pin's internal pull-down resistor.

The power-up configuration is interlaced NTSC-M, 27 MHz black burst video, as listed in the default values of the register bit map.

NOTE: To enable active video, black burst video must be turned off by setting register bit EACTIVE (1D[1]) to 1. Other video configurations must be programmed using the part's serial programming interface registers.

2.2 Digital Video Ports

Internally, data to the Bt860/861 is treated as either video, overlay, or alpha data. Video data is the primary visual program content, while overlay data is used for informational or navigational content displayed over the visual program. Alpha data controls the pixel blending of the video and overlay content. Sufficient flexibility exists in the Bt860/861 to allow for a variety of source and blending configurations and interesting visual effects.

Video data is supplied by either the P (Primary Video) port, or the VID (Secondary Video) port. Overlay data can be supplied by either the P port or the OSD (On Screen Display) port. Alpha data can be supplied by the ALPHA port, or embedded in the two LSBs of the overlay luminance data. [Figure 2-1](#) illustrates the pixel latching and blending mechanism.

Figure 2-1. Pixel Latching and Blending Mechanism

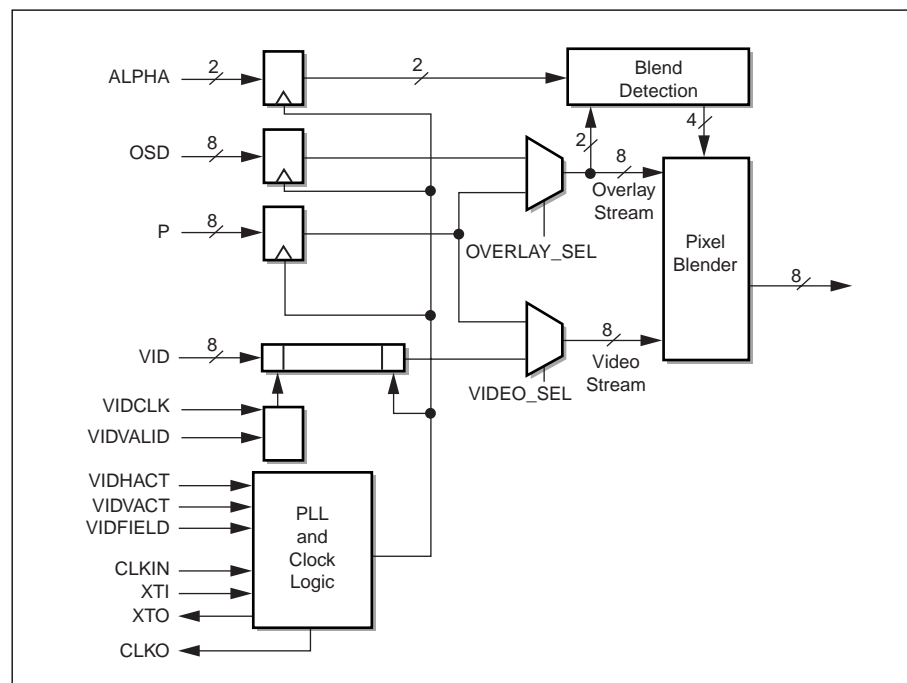

861_042

2.2.1 The P Port

The P port can accept video data from a variety of digital video sources. It is designed specifically to interface directly with commercial MPEG video decoders and D1 digital video sources. The P port supports both ITU-R BT.601 timing (HSYNC* and VSYNC* signals), and ITU-R BT.656 timing (SAV and EAV codes).

Data on the P[7:0] pins can be treated as either video or overlay data, controlled by the VIDEO_SEL (1A[3]) and OVLAY_SEL (1A[4]) register bits (see [Figure 2-1](#)). Data on this port must be presented in 8-bit YCrCb 4:2:2 digital video format. The P[7:0] pins are latched using the system clock as configured using register bits PCLK_SEL (19[7]) and PCLK_EDGE (19[1]).

2.2.2 The VID Port

The VID port is specially configured for broadcast video sources, such as from a television tuner or local cable system. It can accept a 27 MHz YCrCb 4:2:2 video stream at the same pixel rate as the other ports, or it can accommodate alternate clock rates, such as the $8 \times F_{sc}$ clock rate used by the Bt835 family of video decoders. Since the time base for these sources is external to the system and therefore asynchronous to the local pixel clock, the Bt860/861 provides a mechanism that synchronizes these two domains. When using the VID port in locking mode, the Bt860/861 immediately synchronizes its vertical timing to the vertical timing presented on the VIDVACT pin, and gradually adjusts its horizontal timing and clock rate to further synchronize with the VID port. VIDCLK latches the incoming data into a FIFO, and data is extracted at the appropriate pixel rate for internal processing.

The average active horizontal pixel count must be equal to the value programmed into the HACTIVE register field. For example, the Bt835 generates pixels at a rate of 14.32 Mpix/s when used for NTSC video capture, but the actual valid pixel count per line is determined by the video mode required. For support of 27 MHz streams, 720 valid pixels will be delivered per line. This configuration is compatible with other video devices connected to the Bt860/861 and running with a continuous pixel rate of 13.5 Mpix/s. The Bt860/861 will generate the necessary video timing and pixel clock to act as master for the other video device.

The VID port can be configured as the video source by setting register bit VIDEO_SEL (1A[3]) to 1. Data on this port must be presented in 8-bit YCrCb 4:2:2 digital video format.

2.2.3 The OSD Port

The OSD port is functionally very similar to the P port, except that it cannot decode ITU-R BT.656 timing. As the overlay source, this port can be mixed with the video stream using one of the alpha-mixing modes described in [Section 2.2.5](#). While intended as an overlay source, the OSD port can be configured to be the sole image content by using the appropriate blend programming.

The overlay source is selected by setting register bit OVLAY_SEL (1A[4]) to 1. Data on this port must be presented in 8-bit YCrCb 4:2:2 digital video format. The OSD[7:0] pins are latched using the system clock as configured by register bits PCLK_SEL (19[7]) and PCLK_EDGE (19[1]).

2.2.4 Overlay Modes and Alpha Blending

The Bt860/861 can be configured to display only a single video stream, or to mix any combination of two data ports (P, VID, and OSD). Programming register field ALPHAMODE (1A[6:5]) to 00 and register bit BLENDMODE (1A[7]) to 1 selects the internal video bus as the sole source of data, regardless of the alpha source. In this mode, either the VID port or the P port can be used as the video source, which is selected by register bit VIDEO_SEL (1A[3]). Other combinations of the ALPHAMODE and BLENDMODE programming will allow blending of the video and overlay buses. Table 2-1 lists all valid input modes.

Table 2-1. Alpha Blending Configurations

Configuration				Programming				
Video source	Overlay source	Alpha Source	Blending depth	BLENDMODE	ALPHAMODE	VIDEO_SEL	OVERLAY_SEL	Use ALPHA_LUT_X
VID	None	None	None	1	00	1	X	No
VID	P	ALPHA[1:0]	1 bit	1	01	1	0	Yes
VID	P	ALPHA[1:0]	2 bit	1	10	1	0	Yes
VID	P	ALPHA[1:0]	4 bit	1	11	1	0	No
VID	P	P LSBs	2 bit	0	XX	1	0	Yes
VID	OSD	ALPHA[1:0]	1 bit	1	01	1	1	Yes
VID	OSD	ALPHA[1:0]	2 bit	1	10	1	1	Yes
VID	OSD	ALPHA[1:0]	4 bit	1	11	1	1	No
VID	OSD	OSD LSBs	2 bit	0	XX	1	1	Yes
P	None	None	None	1	00	0	X	No
P	OSD	ALPHA[1:0]	1 bit	1	01	0	1	Yes
P	OSD	ALPHA[1:0]	2 bit	1	10	0	1	Yes
P	OSD	ALPHA[1:0]	4 bit	1	11	0	1	No
P	OSD	OSD LSBs	2 bit	0	XX	0	1	Yes

NOTE(S): X or XX = Don't care.

Data from the overlay source may be applied with varying levels of transparency, from fully transparent, no overlay, to fully opaque, full overlay. A 4-bit blend multiplier provides sixteen levels of mixing. The value 1111 is a special case allowing the overlay data to pass completely unmixed. In all other cases the value applied to the video path is $(1 - blend / 16)$, and the value applied to the overlay path is $(blend / 16)$, where *blend* is the 4-bit multiplier value.

Two methods are used to generate the 4-bit multiplier. The multiplier value can come either from a four-entry by 4-bit lookup table (LUT), or directly from the ALPHA pins. In both cases, the blend multiplier value will be applied to both luma and chroma for the co-sited components (Cb0:Y0:Cr0) and a separate multiplier applied for the (Y1) component.

2.2.5 Alpha Pin Blending

The ALPHA[1:0] pins are used to select the amount of blending per pixel when BLENDMODE = 1. The pins are sampled at the system clock rate and samples during both luma and chroma components may be captured to create 1-, 2-, or 4-bit blend factors. For 1- and 2-bit blend modes, the multiplier LUT (in registers ALPHA_LUT_0 through ALPHA_LUT_3) is programmed with user-defined multiplier values.

In 1-bit blend mode, the ALPHA[0] pin indexes registers ALPHA_LUT_0 and ALPHA_LUT_3 to generate the multiplier value. In 2-bit blend mode, the ALPHA[1:0] pins are used as a 2-bit index for registers ALPHA_LUT_0 through ALPHA_LUT_3.

In 4-bit blend mode, the four bits required are captured in successive load clocks from ALPHA[1:0]. The two LSBs of the 4-bit value are latched during the luma portion of the overlay data load, and the two MSBs are latched during the chroma component load. These four bits provide a direct multiplier for the blending module. Figure 2-2 illustrates the alpha blending timing diagram.

Figure 2-2. Alpha Blending Timing Diagram

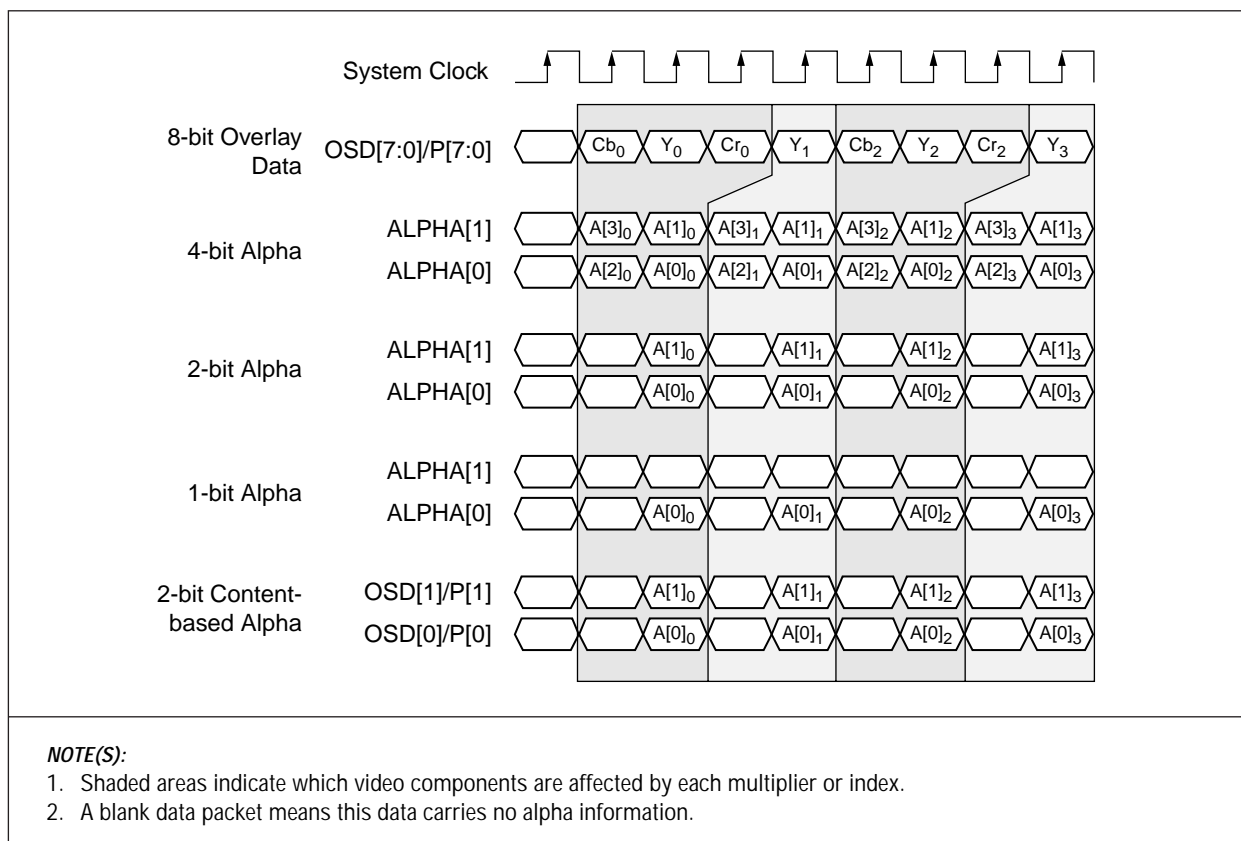

861_026

2.2.6 Content-based Blending

Content-based blending uses the two LSBs of the overlay byte associated with the luma pixel to address the multiplier lookup table (registers ALPHA_LUT_0 through ALPHA_LUT_3). This method is selected by setting BLENDMODE = 0, and is a convenient means of using blending when no alpha pins exist from the overlay device.

2.3 Configurations and Timing

The Bt860/861 is capable of various ITU-R BT.601, ITU-R BT.656, and decoder-locked configurations. [Table 2-2](#) lists several ITU-R BT.601 and ITU-R BT.656 configurations, and [Section 2.3.3](#) discusses decoder-locked configurations. In any of these configurations, it is possible to synchronize a primary video source with an alternate video source. These two sources can then be alpha-mixed, or independently selected for external display. Alpha mixing is discussed in detail in [Section 2.2.5](#).

Table 2-2. Configurable Timing States

Description	Timing Mode	SLAVE	EN_656	SYNC_CFG
Bt860/861 is timing master, HSYNC*, VSYNC*, and FIELD ⁽¹⁾ , are outputs.	1	0	0	1
Bt860/861 is timing slave, timing derived from HSYNC*, VSYNC*, and BLANK* signals ⁽²⁾ .	2	1	0	X
Bt860/861 is timing slave, timing derived from ITU-R BT.656 codes. HSYNC*, and VSYNC* are unused.	3	1	1	0
Bt860/861 is timing slave, timing derived from ITU-R BT.656 codes. HSYNC*, VSYNC*, and FIELD ⁽¹⁾ are outputs.	4	1	1	1
<p>NOTE(S):</p> <p>(1) Decoder locking using the VID port requires the part to be in timing mode 1, except SYNC_CFG = 1 is only required if synchronization with other sources is required.</p> <p>(2) Either the BLANK* pin or the HBLANK, VBLANK, HACTIVE, and VACTIVE register can be used for blanking.</p> <p>3. Configurations not listed are not recommended.</p> <p>4. X = Don't care.</p>				

2.3.1 ITU-R BT.601 Configurations and Timing

Master and slave ITU-R BT.601 configurations are listed in Table 2-2 as timing modes 1 and 2. Timing mode 1 is the ITU-R BT.601 master mode. An example connection diagram is illustrated in Figure 2-3. In this example, both video sources are slaved to the Bt860/861.

Figure 2-3. Timing Mode 1 Connection Example

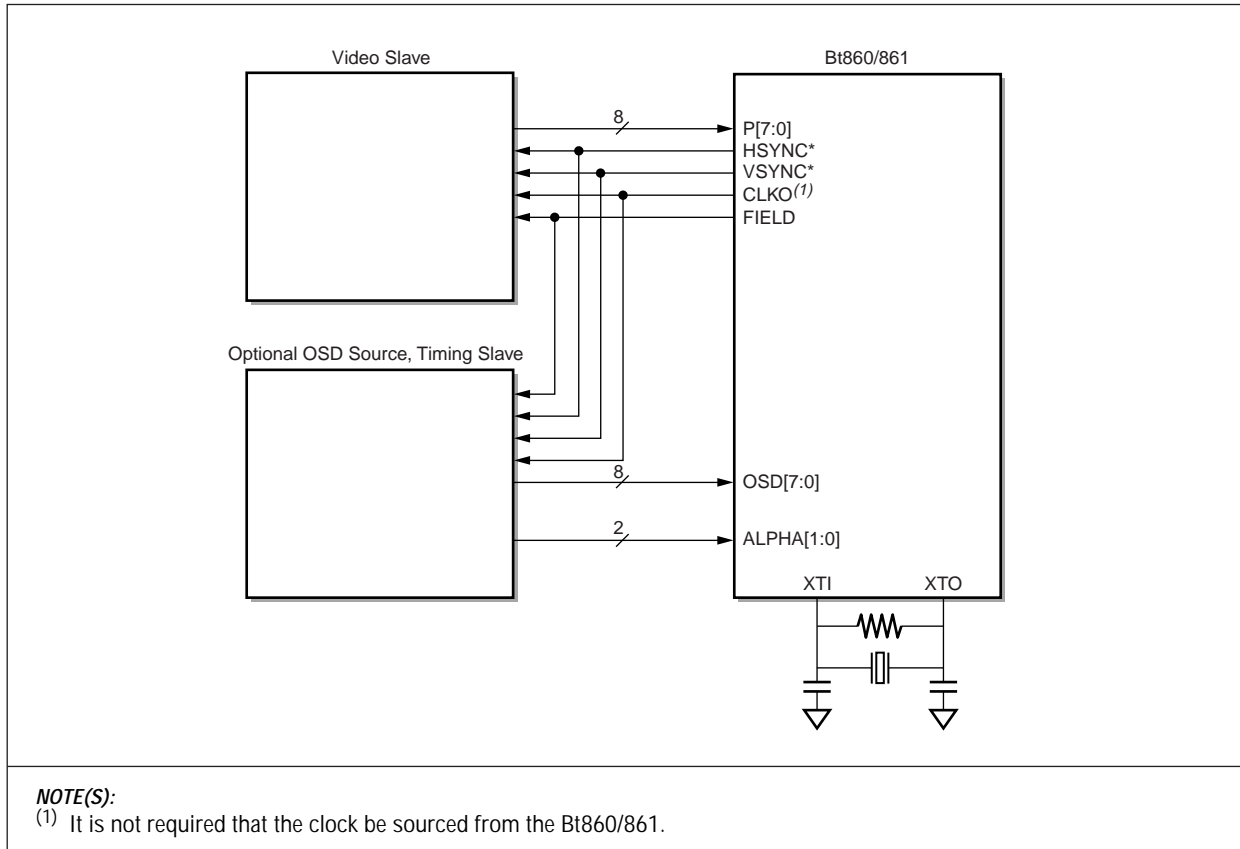

NOTE(S):
 (1) It is not required that the clock be sourced from the Bt860/861.

861_009

Timing mode 2 is the ITU-R BT.601 slave mode. An example connection diagram is illustrated in Figure 2-4. In this example, the source feeding the P port is the timing master, and both the optional OSD source and the Bt860/861 are timing slaves. Although additional sources are shown in these diagrams, it is not necessary to have more than one video source.

Figure 2-4. Timing Mode 2 Connection Example

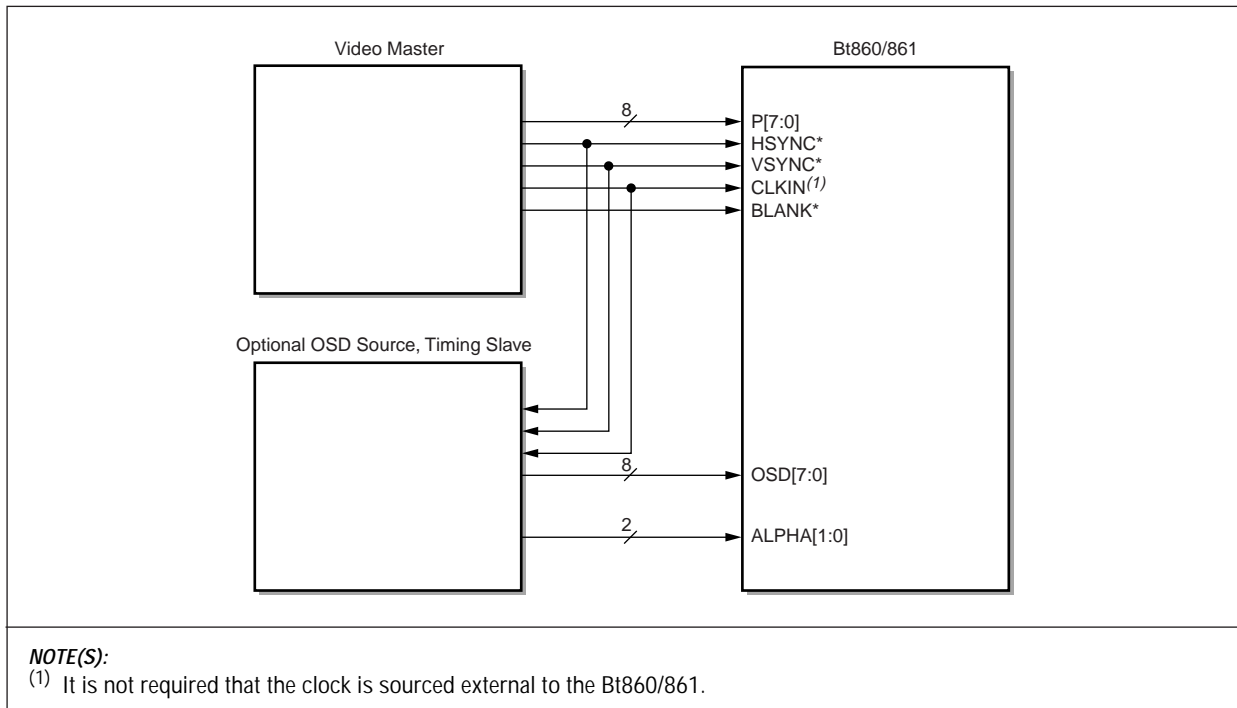

861_007

When the Bt860/861 is configured for ITU-R BT.601 timing, the HSYNC*, VSYNC*, FIELD, and BLANK* pins synchronize the Bt860/861 to external video sources. In master mode, HSYNC* field, and VSYNC* are outputs and the BLANK* pin is not used. All timing is generated internally and blanking is determined by the HBLANK, VBLANK, HACTIVE, and VACTIVE registers. In slave mode, HSYNC*, VSYNC* and BLANK* are inputs and the encoder's timing is controlled by an external master. Blanking is set either by the internal HBLANK, VBLANK, HACTIVE, and VACTIVE registers (register bit BLK_IGNORE = 1) or by a blanking signal on the BLANK* pin (register bit BLK_IGNORE = 0).

If the registers are used to determine video blanking (register bit `BLK_IGNORE = 1`), the first component of the first active pixel of a line should be presented to the encoder at `HBLANK + 2` rising system clock edges after the falling edge of `HSYNC*` for master mode, and `HBLANK + 3` rising system clock edges after the falling edge of `HSYNC*` for slave mode. The correct order of the pixel components is `Cb0, Y0, Cr0, Y1, Cb2, Y2, Cr2...` [Figure 2-5](#) illustrates this timing relationship.

Figure 2-5. Pixel Timing for Timing Modes 1 and 2

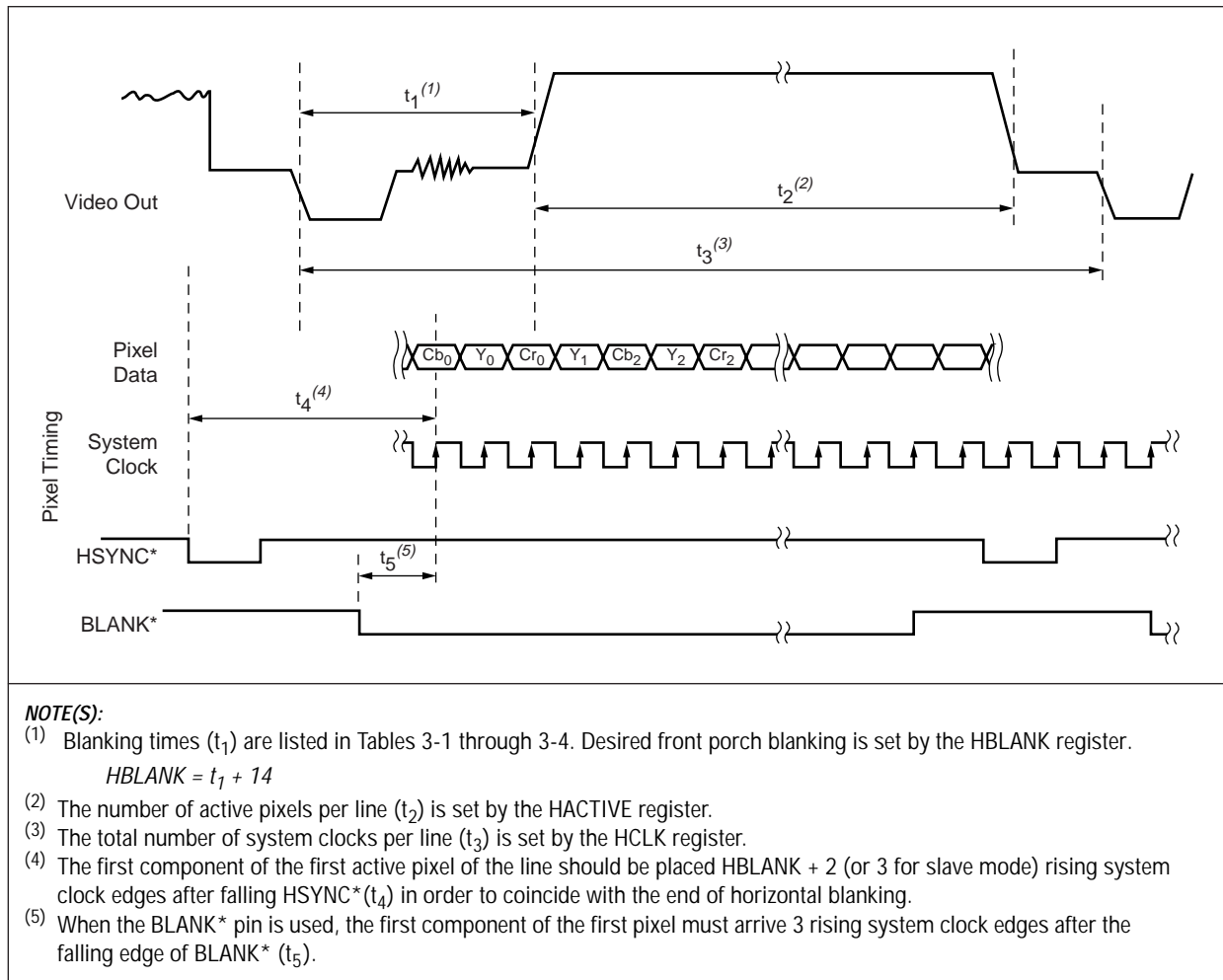

861_006

If the `BLANK*` signal is used to determine video blanking (in slave mode only), the first component of the first active pixel of a line should be presented to the encoder three rising system clock edges after the falling edge of the `BLANK*` signal. [Figure 2-5](#) illustrates this relationship.

The HBLANK register sets the line blanking time from the midpoint of the falling edge of the analog horizontal sync pulse to the end of blanking. The HACTIVE register sets the number of active pixels after the horizontal blanking period has ended. See [Tables 3-1](#) through [3-4](#) for appropriate HBLANK and HACTIVE programming values for various NTSC, PAL, and SECAM video standards.

Pixel and data timing (P, OSD, ALPHA, HSYNC*, VSYNC*, BLANK*) are by default, latched into the Bt860/861 on the rising edge of the system clock, but can be latched on the falling edge of the system clock if register bit PCLK_EDGE (19[1]) is set high. The system clock can be seen on CLKO or CLKIN when appropriate. Legal setup and hold times must be observed.

2.3.2 ITU-R BT.656 Timing

Data on the P port can be routed through the part's ITU-R BT.656 timing translator only when the system clock is 27 MHz, by setting register bit EN_656 (1A[2]) high. This is accomplished using timing modes 3 or 4 (see [Table 2-2](#)). [Figure 2-6](#) illustrates an example connection diagram. ITU-R BT.656 timing derives vertical and horizontal timing information from the video data stream (SAV and EAV codes). These codes are internally converted to HSYNC* and VSYNC* signals, which can be then be produced on the Bt860/861's HSYNC*, VSYNC*, and FIELD pins. ITU-R BT.656 timing (also known as D1 timing) is illustrated in [Figures 2-7](#) and [2-8](#). The resultant video is automatically aligned to conform to ITU-R BT.656 video and blanking placement. The contents of the HBLANK, HACTIVE, VACTIVE, and VBLANK registers are ignored, except when register bit BLK_IGNORE = 1.

Figure 2-6. Timing Mode 3 and 4 Connection Example

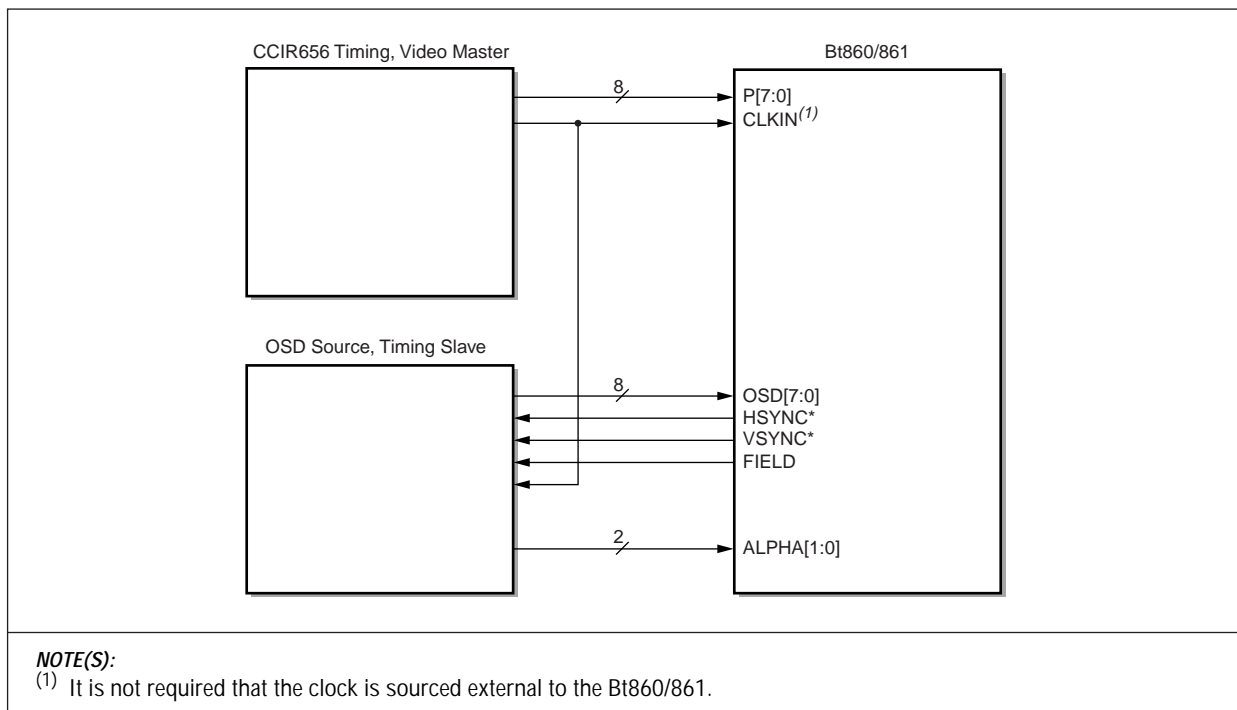

861_010

Figure 2-7. 625 Line ITU-R BT.656 Timing

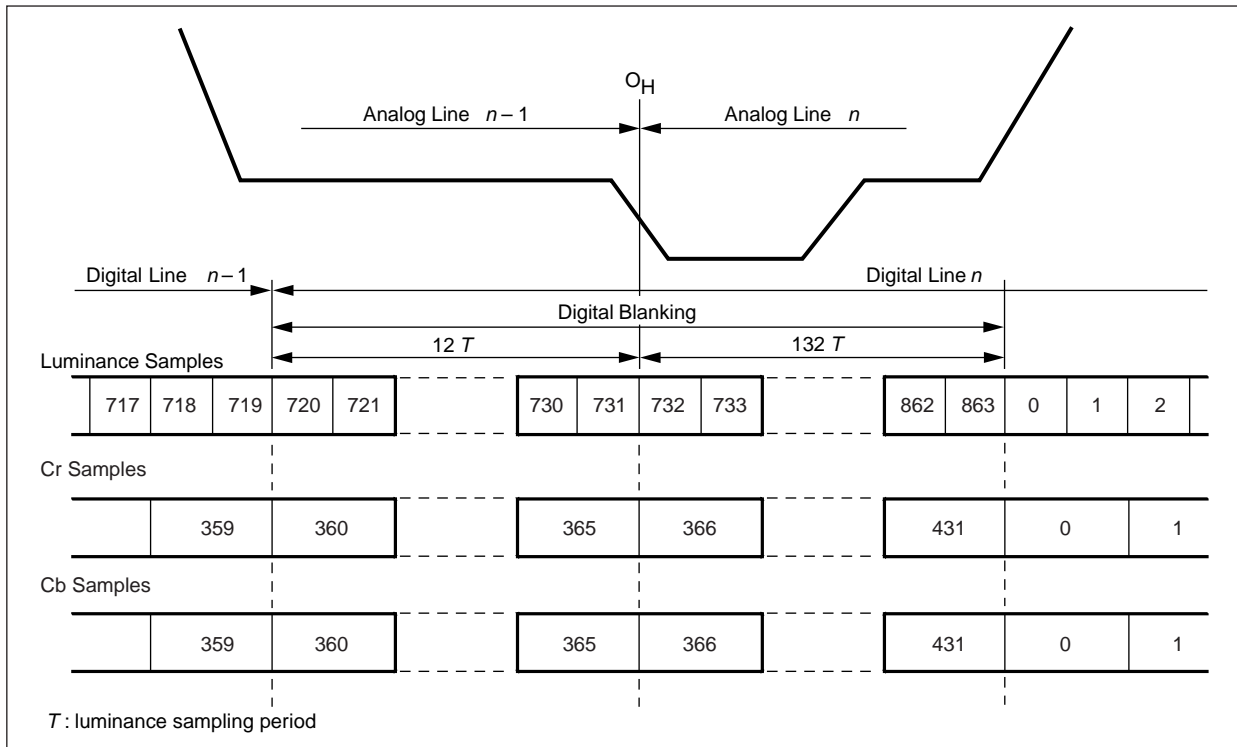

861_005a

Figure 2-8. 525 Line ITU-R BT.656 Timing

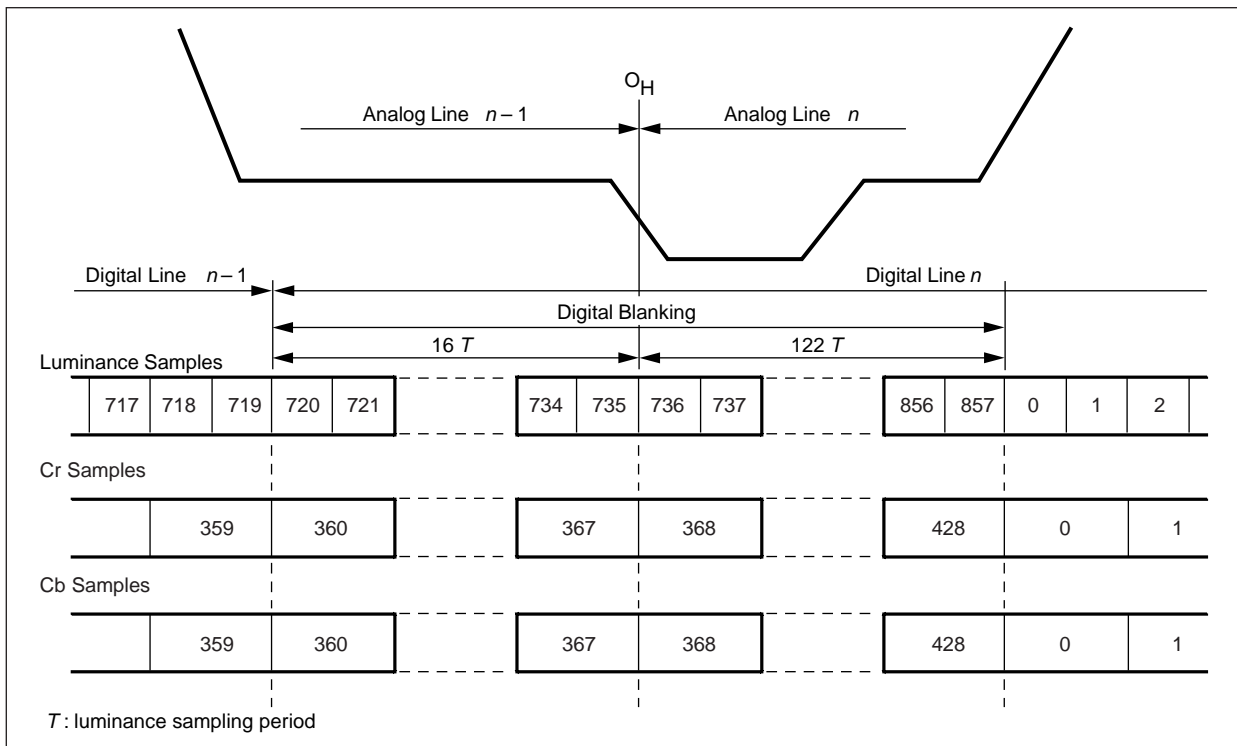

861_005b

In this configuration, the Bt860/861 is a slave to the ITU-R BT.656 data stream. However, the HSYNC*, VSYNC* and FIELD pins can be configured as outputs for synchronization with a video slave on the OSD port. While in this configuration, the HSYNC*, VSYNC*, and FIELD timing is identical to ITU-R BT.601 master mode timing.

2.3.3 VID Port (Video Decoder Locked) Timing

The VID port can accept video signals from a video decoder, such as the Bt835, and is buffered using a FIFO to support asynchronous video streams. The internal logic will automatically pull data from the FIFO when required. The data lines for the VID port are VID[7:0], and the control lines are VIDCLK, VIDHACT, VIDVACT, VIDFIELD, and VIDVALID. [Figure 2-9](#) illustrates an example configuration using the Bt835 and the Bt860. The PLL and the horizontal and vertical counters are adjusted to track the incoming data on the VID port. The Bt860/861 can be configured to output HSYNC* and VSYNC* signals in order to synchronize with the P, OSD, and ALPHA signals. Timing mode 1 must be used when the VID port is selected in conjunction with a source on the P or OSD ports. The PLL (using the XTI and XTO inputs) must be selected as the system clock source.

Figure 2-9. Video Decoder Connection Example

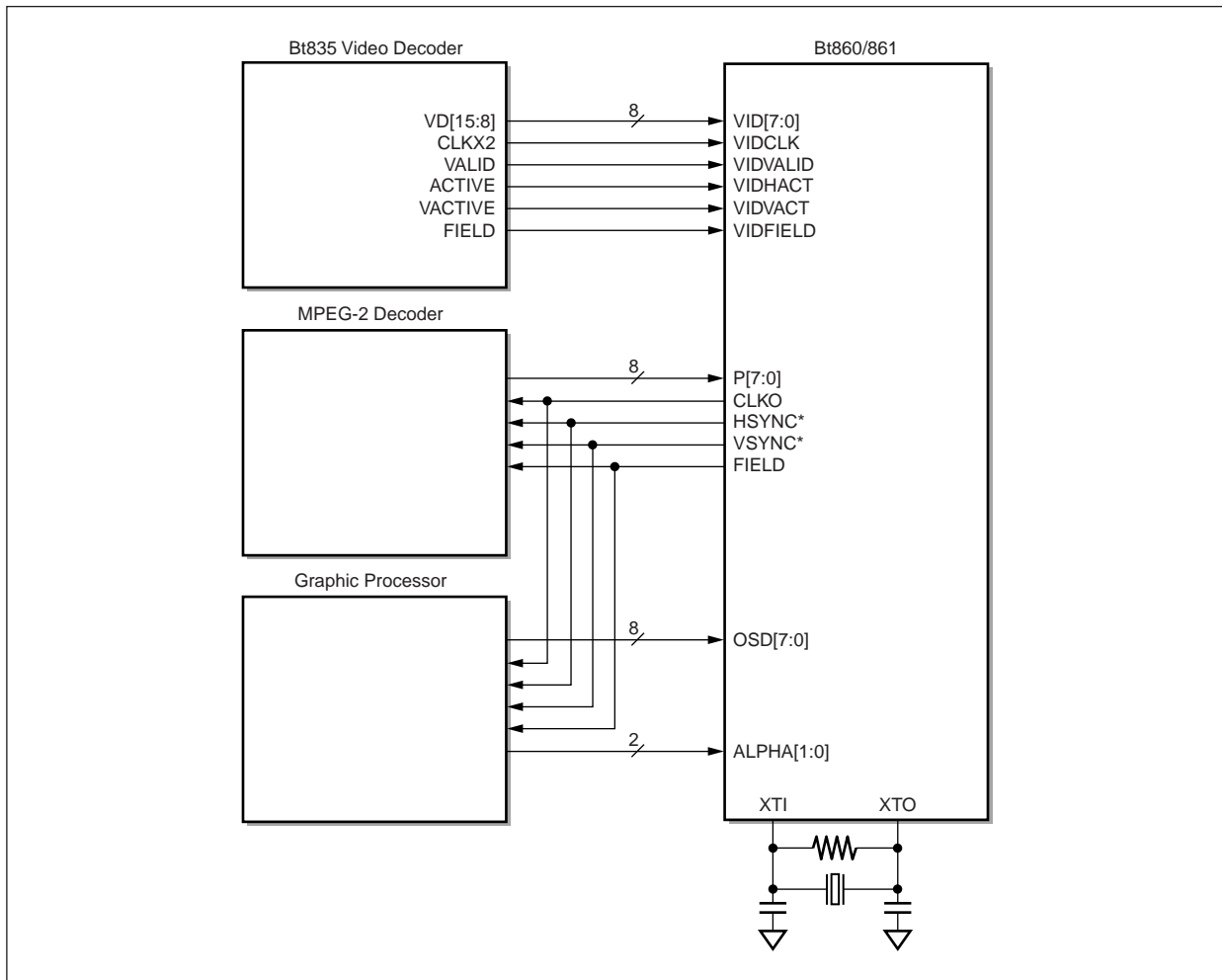

861_008

Follow these steps to lock a video decoder to this port:

1. Connect to the data and control pins as illustrated in Figure 2-9.
2. Select the correct effective clock frequency using the PLL_FRACT and PLL_INT registers, and choose the XTAL inputs as the system clock source using register bit PCLK_SEL (19[7]). See Section 2.4.1, and the PLL_FRACT and PLL_INT register descriptions.
3. Set these locking registers to the following values:

FIELD NAME	VALUE
XL_MDSEL[1:0]	11
XL_SATEN	1
XL_SAT[3:0]	1

4. Set the part for Timing Mode 1 (see Table 2-2).
5. Initiate locking by setting the LOCK (1C[5]) register bit high and the LC_RST (1C[6]) register bit low.

NOTE: When unlocking the Bt861 to a source on the VID port, set the LOCK (1C[5]) register bit low and the LC_RST (1C[6]) register bit high.

2.4 Clock Selection

The internal pixel clock (PCLK) can be derived from either the CLKIN input or the crystal inputs. The PCLK_SEL register bit (19[7]) controls which of these two inputs will become the pixel clock.

2.4.1 Crystal Inputs and the PLL

The crystal inputs (XTI and XTO) drive a buffered oscillator to create a clock. This clock is routed through the PLL if register bit BY_PLL (1D[3]) is 0, and bypasses the PLL untouched if BY_PLL is 1. Figure 2-10 illustrates the clock block diagram. If PCLK_SEL is low, this becomes the system clock.

The PLL_FRACT and the PLL_INT registers determine the PLL clock frequency multiplier. The default setting generates a 27.0 MHz clock, using a 14.31818 MHz crystal.

If the VID port is enabled using the LOCK (1C[5]) register bit, the PLL is controlled by the tracking servo mechanism.

The frequency programmed through PLL_FRACT and PLL_INT is used as a base around which the VID port locking mechanism adjusts the system clock. The PLL_FRACT and PLL_INT registers remain unaffected by the locking mechanism, and when locking is disabled (through the LOCK bit), the PLL_FRACT and PLL_INT registers once again determine the exact PLL frequency.

Figure 2-10. Timing and Clock Block Diagram

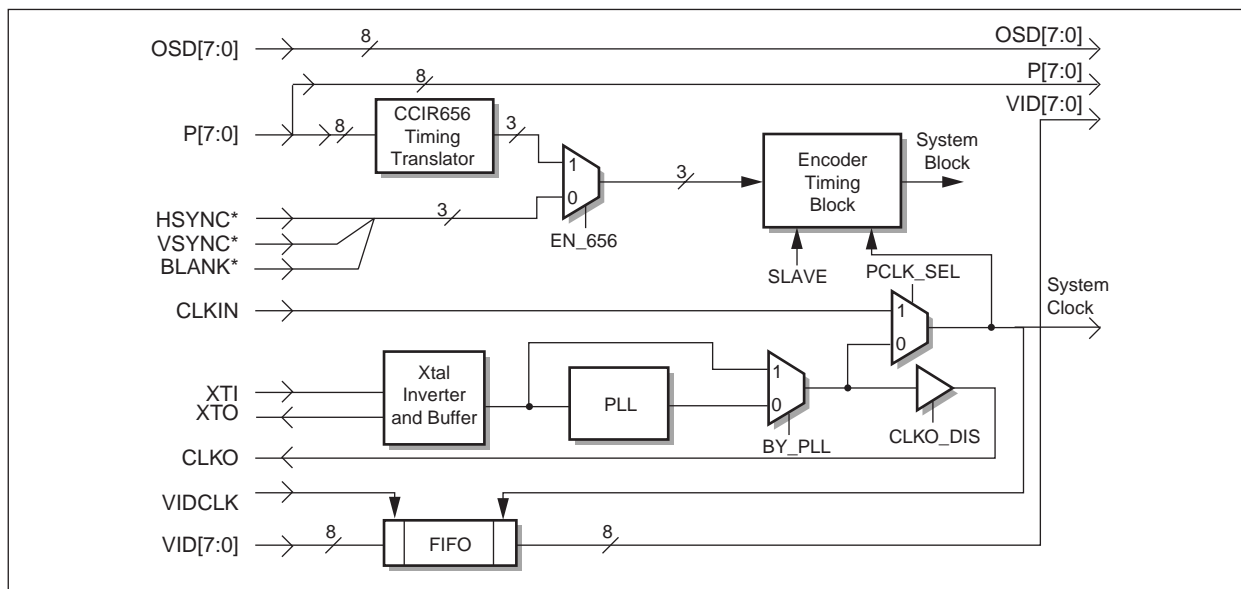

3.0 Digital Processing and Functionality

3.1 Video

3.1.1 Video Standards

The Bt860/861 supports worldwide video standards, including NTSC-M (N. America, Taiwan, Japan), PAL-B, D, G, H, I (Europe, Asia), PAL-M (Brazil), PAL-N (Uruguay, Paraguay), PAL-Nc (Argentina), PAL-60, NTSC-443, and SECAM.

[Table 3-1](#) lists the target video timing and amplitude used to generate the appropriate register programming for various forms of NTSC, PAL, and SECAM as listed in [Tables 3-2](#), [3-3](#), and [3-4](#) respectively. These tables provide the programming values of only those registers required to create that particular video standard. Ancillary data, input configuration, and ignored or common value register values are not shown. Video parameter registers which are not relevant to a particular standard are described as such in the register detail section of this document.

[Table 3-2](#) lists the register values required to program the various forms of PAL and NTSC in ITU-R BT.601 resolution, and [Table 3-3](#) lists the register values required to program the various forms of PAL and NTSC in square pixel resolution. [Table 3-4](#) lists register values required to program the encoder for SECAM output, with and without synchronization bottleneck pulses.

Table 3-1. Target Video Parameters (1 of 2)

Parameter Description	Video Standard										
	NTSC-M	NTSC-J	NTSC-443	PAL-M	PAL-60	PAL-B, D, G, H, I	PAL-N	PAL-Nc	SECAM		
HSYNC Width (µs)	4.7	4.7	4.7	4.7	4.7	4.7	4.7	4.7	4.7	4.7	
HSYNC and VSYNC Height (V)	0.286	0.286	0.2857	0.2857	0.3	0.3	0.2857	0.3	0.3	0.3	
HSYNC Rise/Fall Time (10% to 90%) (ns)	150	150	150	150	150	200 ⁽¹⁾	200	200	200	200	
Burst or Subcarrier Start (µs)	5.3	5.3	5.3	5.8	5.3	5.6	5.6	5.6	5.6	5.6	
Burst Width (µs)	2.514 (9 cycles)	2.514 (9 cycles)	2.25 (10 cycles)	2.52 (9 cycles)	2.25 (10 cycles)	2.25 (10 cycles)	2.25 (10 cycles)	2.51 (9 cycles)	N/A	N/A	
Subcarrier Frequency ⁽²⁾ (Hz)	3579545	3579545	4433618.75	3579611.49	4433618.75	4433618.75	4433618.75	3582056.25	for=4406250, fob=4250000	0.161	
Burst or Subcarrier Height (V)	0.2857	0.2857	0.2857	0.306	0.3	0.3	0.3	0.3	0.3	0.161	
Phase Alternation	NO	NO	NO	YES	YES	YES	YES	YES	NO	NO	
Number of Lines per Frame	525	525	525	525	525	625	625	625	625	625	
Line Frequency (Hz)	15734.264	15734.264	15734.264	15734.264	15734.264	15625	15625	15625	15625	15625	
Field Frequency (Hz)	59.94	59.94	59.94	59.94	59.94	50	50	50	50	50	
Setup	YES	NO	YES	YES	NO	NO	YES	NO	NO	NO	
First Active Line	22 ⁽³⁾	22 ⁽³⁾	22 ⁽³⁾	22 ⁽³⁾	22 ⁽³⁾	23 ⁽⁴⁾	23 ⁽⁴⁾	23 ⁽⁴⁾	23 ⁽⁴⁾	23 ⁽⁴⁾	
Last Active Line	262 ⁽³⁾	262 ⁽³⁾	262 ⁽³⁾	262 ⁽³⁾	262 ⁽³⁾	309 ⁽⁴⁾	309 ⁽⁴⁾	309 ⁽⁴⁾	309 ⁽⁴⁾	309 ⁽⁴⁾	
HSYNC to Blank End (µs) ⁽⁵⁾	9.2 [9.037]	9.2	9.2	9.2	9.2	10.5 [9.778]	9.2	10.5	10.5	10.5	

Table 3-1. Target Video Parameters (2 of 2)

Parameter Description	Video Standard									
	NTSC-M	NTSC-J	NTSC-443	PAL-M	PAL-60	PAL-B, D, G, H, I	PAL-N	PAL-Nc	SECAM	
Blank Begin to HSYNC (μ s) ⁽⁵⁾	1.5[1.185]	1.5	1.5	1.5	1.5	1.5[0.889]	1.5	1.5	1.5	
Black to 100% White (V)	0.661	0.714	0.661	0.661	0.7	0.7	0.661	0.7	0.7	
Number of Lines each for Vertical Serration, Equalization	3	3	3	3	3	2.5	3	2.5	2.5	

NOTE(S):

- (1) Value for PAL-I is 250 ns.
- (2) When programming the subcarrier increment, use relationship of F_{sc} to F_h as given in ITU-R BT.470 instead of F_{sc} and F_{clk} .
- (3) Using NTSC line numbering convention from ITU-R BT.470.
- (4) Using PAL line numbering convention from ITU-R BT.470.
- (5) ITU-R BT.601 blanking values given in square brackets []

Table 3-2. Register Programming Values for NTSC and PAL Video Standards (ITU-R BT.601) (1 of 2)

Parameter Description	Register Name	Register No.	Video Standard									
			NTSC-M	NTSC-J	PAL-M	NTSC-443	PAL-60	PAL-B, D, G, H, I	PAL-N	PAL-Nc		
Number of Lines	625LINE	16[5]	0	0	0	0	0	0	0	1	1	1
Width of Analog Horizontal Sync Pulse	AHSYNC_WIDTH	08[7:0]	7F	7E	7F	7F	7F	7F	7F	7F	7F	7F
Burst Amplitude	BURST_AMP	1F[7:0]	7A	7B	5E	7A	7A	5E	5E	5D	5D	5D
Cross Color Filter Off	CROSSFILT	1D[0]	1	1	1	1	1	1	1	1	1	1
Frequency Modulated	FM	16[2]	0	0	0	0	0	0	0	0	0	0
Number of Active Pixels Per Line	HACTIVE	07[1:0]/06[7:0]	2C9	2C9	2C9	2C9	2C9	2C9	2C9	2BF	2CF	2BF
Number of System Clocks from O _H to Active Video	HBLANK	0C[1:0]/0B[7:0]	108	108	108	108	108	108	108	128	108	128
Beginning of Burst	HBURST_BEG	09[7:0]	8C	8E	9A	8C	8C	8F	8F	95	95	95
End of Burst	HBURST_END	0A[7:0]	54	52	5C	54	54	52	52	51	51	58
Number of System Clocks Per Line	HCLOCK	05[3:0]/04[7:0]	6B4	6B4	6B4	6B4	6B4	6B4	6B4	6C0	6C0	6C0
Cb Multiplier	M_CB	21[7:0]	8D	9B	8D	8D	8D	9B	9B	9B	9B	9B
Cr Multiplier	M_CR	20[7:0]	C7	DA	C7	C7	C7	DA	DA	DA	DA	DA
Y Multiplier	M_Y	22[7:0]	9A	A5	9A	9A	9A	9A	9A	A2	A2	A2

Table 3-2. Register Programming Values for NTSC and PAL Video Standards (ITU-R BT.601) (2 of 2)

Parameter Description	Register Name	Register No.	Video Standard							
			NTSC-M	NTSC-JAPAN	PAL-M	NTSC-443	PAL-60	PAL-B,D,G,H,I	PAL-N	PAL-Nc
Subcarrier Increment	MSC_DR	29[7:0]/28[7:0] 27[7:0]/26[7:0]	21F07C1F	21F07C1F	21F0A527	2A098ACB	2A098ACB	2A098ACB	2A098ACB	21F69446
Interlace Off	NI	16[1]	0	0	0	0	0	0	0	0
Phase Alternation	PAL	16[3]	0	0	1	0	0	1	1	1
Subcarrier Phase Offset	PHASE_OFF	38[7:0]	00	00	00	00	00	00	00	00
Subcarrier Reset	SC_RESET	16[7]	0	0	0	1	1	1	0	0
SETUP	SETUP	16[4]	1	0	1	1	1	0	1	0
Sync Tip to Blank Amplitude	SYNC_AMP	1E[7:0]	E4	E4	E4	E4	E4	F0	E4	F0
Number of Active Lines	VACTIVE	0F[0]/0E[7:0]	0F1	0F1	0F1	0F1	0F1	0F1	11F	11F
Number of Blanked Lines from 0y	VBLANK	0D[7:0]	13	13	13	13	13	13	17	17
Analog and Digital Vertical Sync Duration	VSYNC_DUR	16[6]	0	0	0	0	0	0	1	1

NOTE(S): Internal timing and the values programmed into the registers reference the analog VSYNC pulse (0y) as line #1 (see Figures 3-1 and 3-2).

Table 3-3. Register Programming Values for NTSC and PAL Video Standards (Square Pixel) (1 of 2)

Parameter Description	Register Name	Register No.	Video Standard								
			NTSC-M	NTSC-JAPAN	PAL-M	NTSC-443	PAL-60	PAL-B,D,G,H,I	PAL-N	PAL-NC	
			System Clock Frequency (MHz)								
Number of Lines	625LINE	16[5]	24.5454	24.5454	24.5454	24.5454	24.5454	24.5454	29.5	29.5	29.5
Width of Analog Horizontal Sync Pulse	AHSYNC_WIDTH	08[7:0]	74	74	74	74	74	74	8A	8A	8A
Burst Amplitude	BURST_AMP	1F[7:0]	7C	7C	5F	7A	5D	5D	5D	5D	5D
Cross Color Filter Off	CROSSFILT	1D[0]	1	1	1	1	1	1	1	1	1
Frequency Modulated	FM	16[2]	0	0	0	0	0	0	0	0	0
Number of Active Pixels Per Line	HACTIVE	07[1:0]/06[7:0]	289	289	289	289	289	289	300	314	300
Number of System Clocks from O _H to Active Video	HBLANK	0C[1:0]/0B[7:0]	0F0	0F0	0F0	0F0	0F0	0F0	140	11C	140
Beginning of Burst	HBURST_BEG	09[7:0]	80	80	8B	80	80	80	A4	A4	A4
End of Burst	HBURST_END	0A[7:0]	3D	3D	4A	3D	3D	3D	65	65	6E
Number of System Clocks Per Line	HLOCK	05[3:0]/04[7:0]	618	618	618	618	618	618	760	760	760

Table 3-3. Register Programming Values for NTSC and PAL Video Standards (Square Pixel) (2 of 2)

Parameter Description	Register Name	Register No.	Video Standard							
			NTSC-M	NTSC-JAPAN	PAL-M	NTSC-443	PAL-60	PAL-B,D,G,H,I	PAL-N	PAL-Nc
Cb Multiplier	M_CB	21[7:0]	90	9C	90	90	99	99	99	99
Cr Multiplier	M_CR	20[7:0]	CB	DC	CB	CB	CB	D8	D8	D8
Y Multiplier	M_Y	22[7:0]	99	A6	99	99	99	A2	A2	A2
Subcarrier Increment	MSC_DR	29[7:0]/28[7:0]/ 27[7:0]/26[7:0]	25555555	25555555	254BF631	2E3DB902	2E3DB902	2E3DB902	26798C0C	1F15C01E
Interlace Off	NI	16[1]	0	0	0	0	0	0	0	0
Phase Alternation	PAL	16[3]	0	0	1	0	0	1	1	1
Subcarrier Phase Offset	PHASE_OFF	38[7:0]	00	00	00	00	00	00	00	00
Subcarrier Reset	SC_RESET	16[7]	0	0	0	1	1	1	0	0
SETUP	SETUP	16[4]	1	0	1	1	1	0	1	0
Sync Tip to Blank Amplitude	SYNC_AMP	1E[7:0]	E4	E4	E4	E4	E4	F0	E4	F0
Number of Active Lines	VACTIVE	0F[0]/0E[7:0]	0F1	0F1	0F1	0F1	0F1	0F1	11F	11F
Number of Blanked Lines from 0y	VBLANK	0D[7:0]	13	13	13	13	13	13	17	17
Analog and Digital Vertical Sync Duration	VSYNC_DUR	16[6]	0	0	0	0	0	0	0	1

NOTE(S): Internal timing and the values programmed into the registers reference the analog VSYNC pulse (0y) as line #1 (see Figures 3-1 and 3-2).

Table 3-4. Register Programming Values for SECAM

Parameter Description	Register Name	Register Number	System Clock Frequency (MHz)	
			27	29.5
Number of Lines	625 Line	16[5]	1	1
Width of Analog Horizontal Sync Pulse	AHSYNC_WIDTH	08[7:0]	7F	8B
Cross Color Filtering Off	CROSSFILT	ID[0]	0	0
Upper Db Limit	DB_MAX	34[1:0]/33[7:0]	5A3	529
Lower Db Limit	DB_MIN	36[1:0]/35[7:0]	49F	43B
Upper Dr Limit	DR_MAX	30[1:0]/2F[7:0]	5A3	529
Lower Dr Limit	DR_MIN	32[1:0]/31[7:0]	49F	43B
Bottleneck Pulses	FIELD_ID	1B[6]	0 ⁽¹⁾	0 ⁽¹⁾
FM Modulation	FM	16[2]	1	1
Number of Active Pixels per Line	HACTIVE	07[1:0]/06[7:0]	2C0	300
Number of System Clocks from O _H to Active Video	HBLANK	0C[1:0]/0B[7:0]	128	140
Beginning of Subcarrier	HBURST_BEG	09[7:0]	97	A5
Number of System Clocks Per Line	HCLOCK	05[3:0]/04[7:0]	6C0	760
Cb Multiplier	M_CB	A2	94	9A
Cr Multiplier	M_CR	C5	B5	BB
Y Multiplier	M_Y	22[7:0]	A4	A4
Subcarrier Increment for Db	MSC_DB	2D[7:0]/2C[7:0] 2B[7:0]/2A[7:0]	284BDA13	24E1A08B
Subcarrier Increment for Dr	MSC_DR	29[7:0]/28[7:0] 27[7:0]/26[7:0]	29C71C72	263CBEEA
Interlace Off	NI	16[1]	0	0
Phase Alternation	PAL	16[3]	0	0
Programmable Subcarrier Mode	PROG_SC	1A[1]	0	0
Subcarrier Amplitude	SC_AMP	86	86	85
Subcarrier Phase Pattern	SC_PATTERN	1A[0]	0	0
Setup	SETUP	16[4]	0	0
Sync Tip to Blank Amplitude	SYNC_AMP	1E[7:0]	F0	F0
Number of Active Lines	VACTIVE	0F[0]/0E[7:0]	11F	11F
Number of Blanked Lines from O _V ⁽²⁾	VBLANK	0D[7:0]	17	17
Analog and Digital Vertical Sync Duration	VSYNC_DUR	16[6]	1	1
NOTE(S):				
(1) To enable synchronization bottleneck pulses, this bit must be 1.				
(2) Internal timing and the values programmed into the registers reference the analog VSYNC pulse (O _V) as line #1 (see Figures 3-1 and 3-2).				

3.1.2 Analog Horizontal Sync

The duration of the horizontal sync pulse is determined by register HSYNC_WIDTH (12[7:0]). The beginning of the horizontal sync pulse corresponds to the reset of the internal horizontal pixel counter. The sync rise and fall times are automatically controlled. The horizontal and vertical sync amplitude is programmable using register SYNC_AMP (IE[7:0]).

3.1.3 Analog and Digital Vertical Sync

The duration of the analog and digital vertical sync is determined by register bit VSYNC_DUR (16[6]). If VSYNC_DUR = 0, 3.0 lines are selected; if VSYNC_DUR = 1, 2.5 lines are selected. [Tables 3-2](#), [3-3](#), and [3-4](#) list the appropriate VSYNC_DUR settings for all supported standards.

[Figures 3-1](#) and [3-2](#) illustrate 3.0 and 2.5 lines respectively.

Figure 3-1. NTSC Vertical Timing

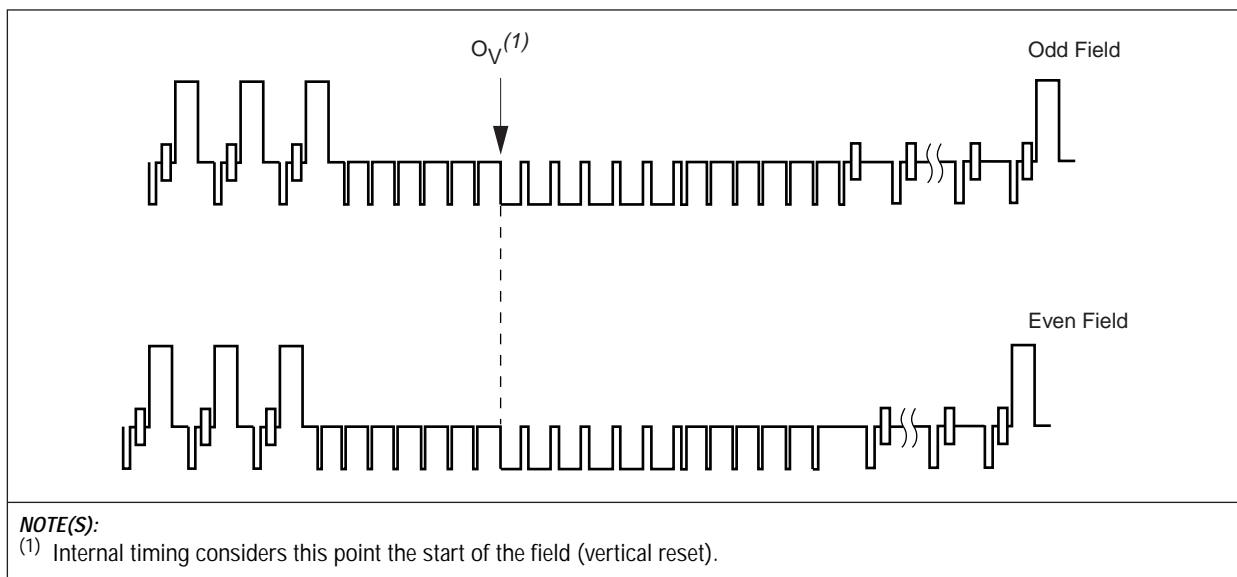

861_032

Figure 3-2. PAL Vertical Timing

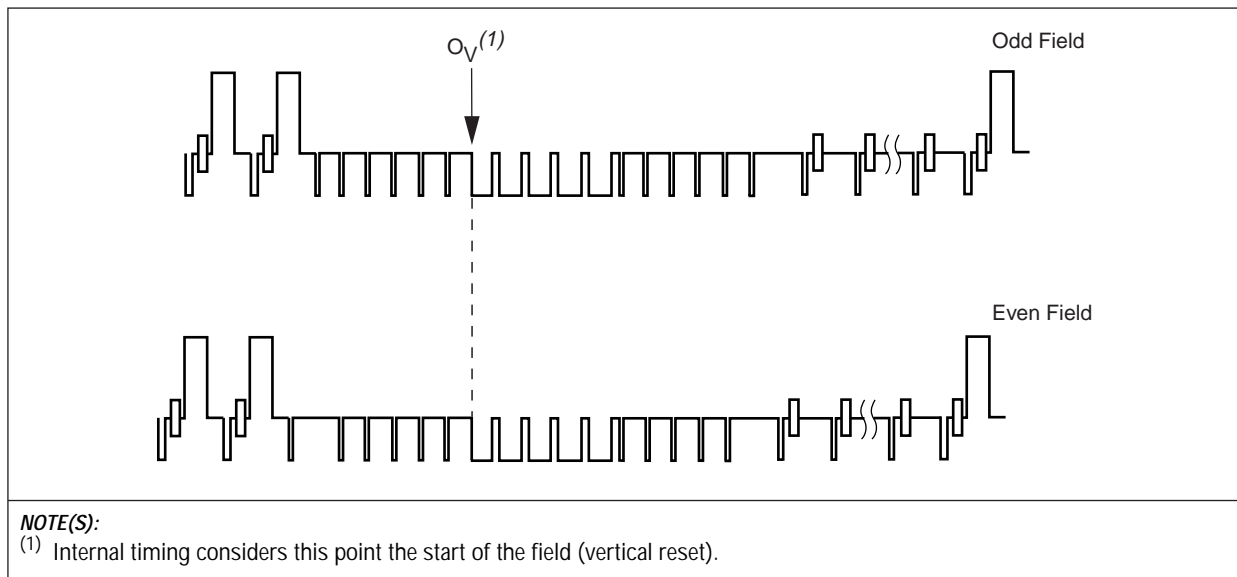

3.1.4 Analog Video Blanking

In master mode, and when register bit `BLK_IGNORE = 1` in slave mode, register fields `HBLANK`, `VBLANK`, `HACTIVE`, and `VACTIVE` control analog video blanking. Together they define the active region, where pixels will be displayed. `VBLANK` defines the number of lines from the leading edge of the analog vertical sync (O_V) to the first active line (see Figures 3-1 and 3-2). `VACTIVE` defines the number of active lines. `HBLANK` defines the number of system clocks (minus 14) from the leading edge of horizontal sync to the first active pixel. `HACTIVE` defines the number of active pixels per line.

In the slave mode, when `BLK_IGNORE = 0`, the `BLANK*` pin determines analog blanking. The video from the start of horizontal sync through the end of the burst, as well as the vertical lines with serration and equalization pulses is automatically blanked.

3.1.5 Subcarrier and Burst Generation

The Bt860/861 uses a 32-bit subcarrier increment to synthesize the subcarrier. The value of the subcarrier increment required to generate the desired subcarrier frequency for NTSC and PAL formats is found by:

$$M_SC_DR[31:0] = \text{int} (2^{32} \times f_{sc} / f_{clk} + 0.5)$$

where f_{clk} is the encoder system clock rate and f_{sc} is the desired subcarrier frequency.

When available, use the relationship between HCLK and the subcarrier frequency as given in ITU-R BT.470. For example:

$$\begin{aligned} \text{NTSC-M: } M_SC_DR[31:0] &= \text{int} \{ [455 / (2 \times HCLK)] \times 2^{32} + 0.5 \} \\ \text{PAL-B: } M_SC_DR[31:0] &= \text{int} \{ [(1135 / 4 + 1 / 625) / HCLK] \times 2^{32} + 0.5 \} \end{aligned}$$

Tables 3-2 and 3-3 lists the programming values for common NTSC and PAL standards.

For SECAM formats, the two subcarrier frequency increments are defined by:

$$\begin{aligned} \text{SECAM Dr: } M_SC_DR[31:0] &= \text{int} [(f_{sc} / f_{clk}) \times 2^{32} + 0.5] \\ \text{SECAM Db: } M_SC_DB[31:0] &= \text{int} [(f_{sc} / f_{clk}) \times 2^{32} + 0.5] \end{aligned}$$

Table 3-4 lists standard programming values for SECAM.

The HBURST_BEG register determines the start of burst (or subcarrier for SECAM). In PAL and NTSC video formats the HBURST_END register determines the end of the burst. The BURST_AMP register controls burst amplitude. The burst is automatically blanked during the horizontal sync to prevent generation of invalid sync pulses. Burst blanking is automatically controlled and depends on which video format is selected. Burst rise and fall times are internally controlled.

The SC_AMP register controls the SECAM subcarrier amplitude. In addition, generation of the “bottleneck signals” for subcarrier line synchronization may be enabled using the FIELD_ID register bit. Registers PROG_SC and SC_PATTERN allow control of active line placement and subcarrier phase sequencing.

3.1.6 Subcarrier Phasing (SC_H Phase)

For PAL and NTSC video formats, the subcarrier phase is set to 0 on the leading edge of the analog vertical sync every four (NTSC) or eight (PAL) fields, unless the SC_RESET bit is set to a logical 1. This is true for both interlaced and non-interlaced outputs. In addition, the subcarrier phase can be adjusted by the PHASE_OFF register. Each LSB change of PHASE_OFF corresponds to a 360 / 256 degree change in the phase.

Setting SC_RESET to 1 is useful when the subcarrier phase at the end of a color field sequence is significantly different from 0.

3.1.7 Noninterlaced Operation

When programmed for noninterlaced master mode, the Bt860/861 always displays the odd field. The FIELD signal stays low to indicate that the field is always odd. A 30 Hz offset should be subtracted from the color subcarrier frequency while in NTSC mode so the color subcarrier phase will be inverted from field to field. Transition from interlaced to noninterlaced in master mode occurs during odd fields to prevent synchronization disturbance.

NOTE: Consumer VCRs can record noninterlaced video with minor noise artifacts, but special effects (e.g., scan >2x) may not function properly.

3.2 Effects

3.2.1 Chrominance Disable

Setting register bit DCHROMA (17[2]) to 1 turns off the chrominance subcarrier and colorburst.

3.2.2 Internal Filtering

Once the input data is converted to internal YUV format, the Y and UV components are filtered and upsampled to the system clock frequency.

The luminance signal is always low-pass filtered using the upsampling filter response illustrated in [Figure 3-3](#). Additional peaking or reduction filters can be enabled (see [Figures 3-4](#) and [3-5](#)), using the PKFIL_SEL register field and the FIL_SEL register bit. When register bit FIL_SEL is set to 0, register field PKFIL_SEL selects the peaking filters illustrated in [Figure 3-7](#). When register bit FIL_SEL is set to 1, register field PKFIL_SEL selects the reduction filters illustrated in [Figure 3-6](#). The peaking filters are optimized for high bandwidth frequency response, and the reduction filters are optimized for step response performance.

The default chrominance filter response is illustrated in [Figure 3-8](#), but an alternate wide bandwidth response can be selected using register bit CHROMA_BW, as illustrated in [Figure 3-9](#).

SECAM pre-emphasis filter responses are illustrated in [Figures 3-10](#) and [3-11](#).

Figure 3-3. Luminance Upsampling Filter

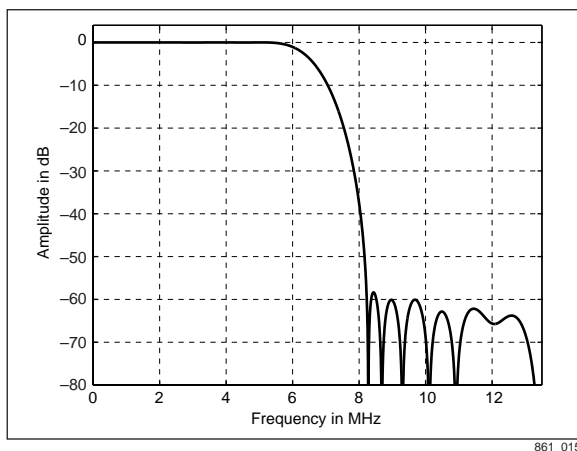

Figure 3-4. Luminance Upsampling Filter with Peaking and Reduction Options

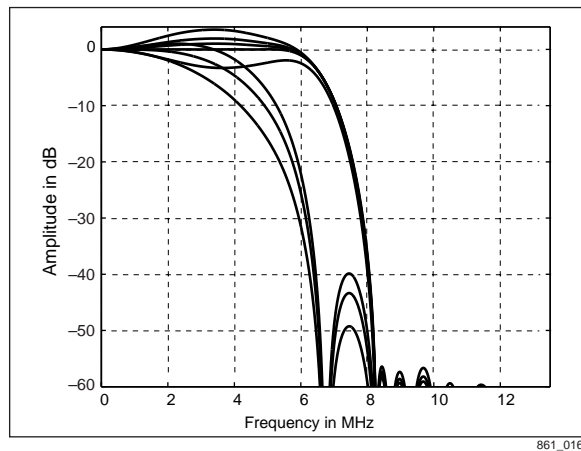

Figure 3-5. Close-Up of Luminance Upsampling Filter with Peaking and Reduction Options

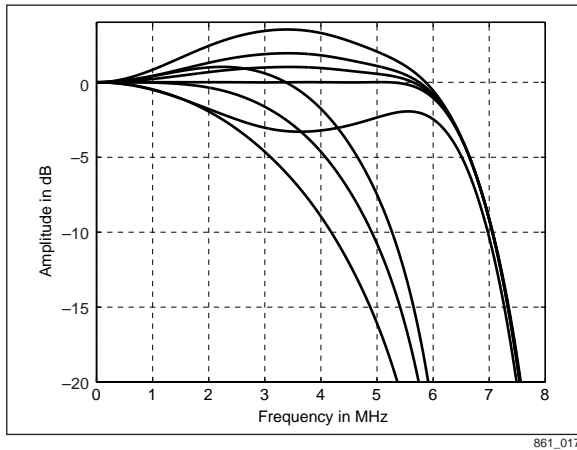

Figure 3-6. Luminance Reduction Filters Options

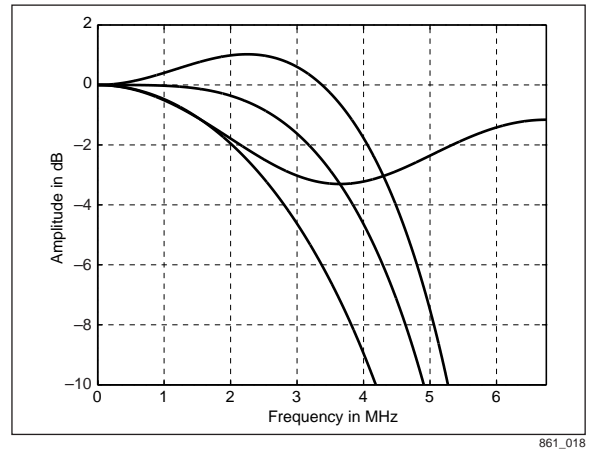

Figure 3-7. Luminance Peaking Filter Options

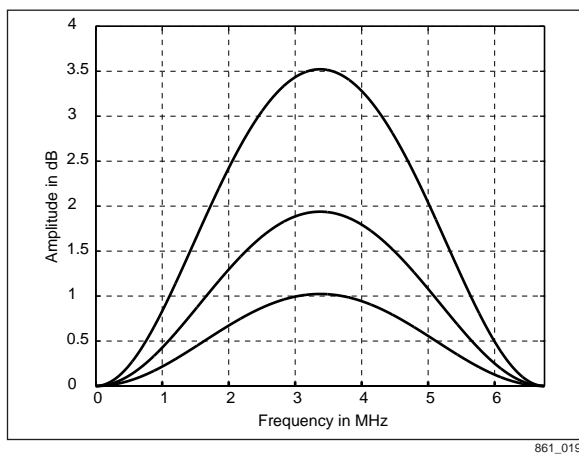

Figure 3-8. Chrominance Filter

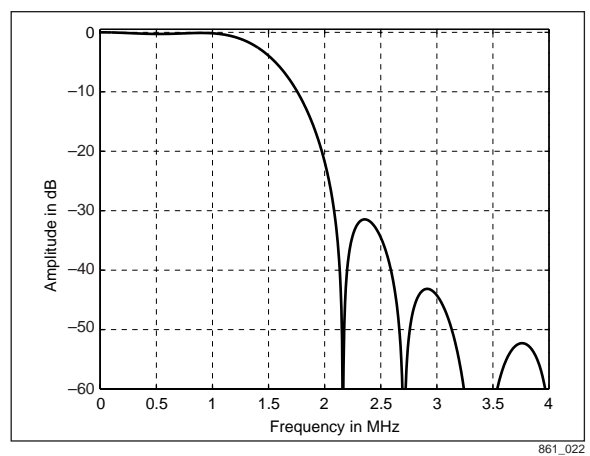

Figure 3-9. Chrominance Wide Bandwidth Filter

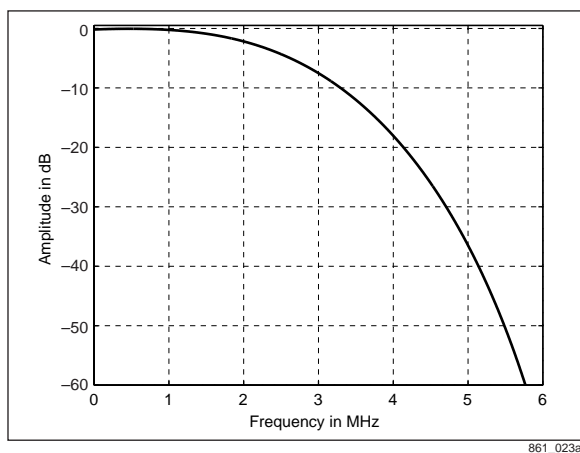

Figure 3-10. SECAM High Frequency Pre-emphasis Filter

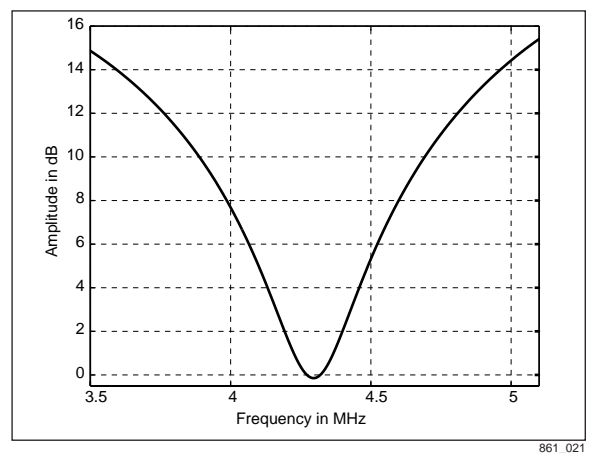
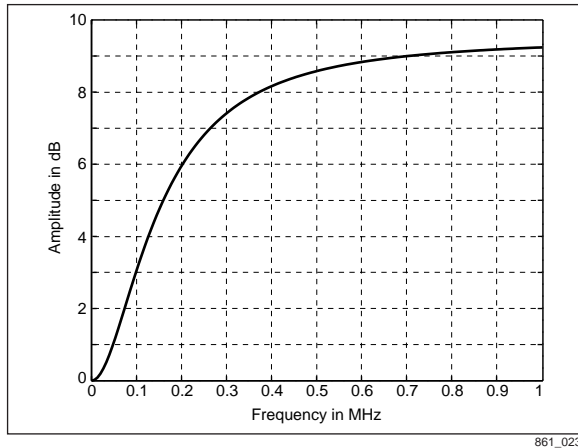

Figure 3-11. SECAM Low Frequency Pre-emphasis Filter



3.2.3 Internal Colorbars, Blue Field, and Black Burst

The Bt860/861 can be configured to generate 100% amplitude, 75% saturation (100/7.5/75/7.5 for NTSC/PAL-M with set-up, 100/0/75/0 for PAL/SECAM) colorbars by setting register bit ECBAR (17[1]) bit to a 1. The Bt860/861 can also produce a blue field by setting register bit BLUE_FLD (17[6]) to 1, and black burst by setting register bit EACTIVE (1D[1]) to 0. Pixel inputs are ignored while any of these waveforms are being produced.

Example colorbars for different output formats are illustrated in [Figures 3-12, 3-13, and 3-14](#). Specific levels are listed in [Tables 3-5 through 3-8](#).

Figure 3-12. YUV Video Format (Internal Colorbars)

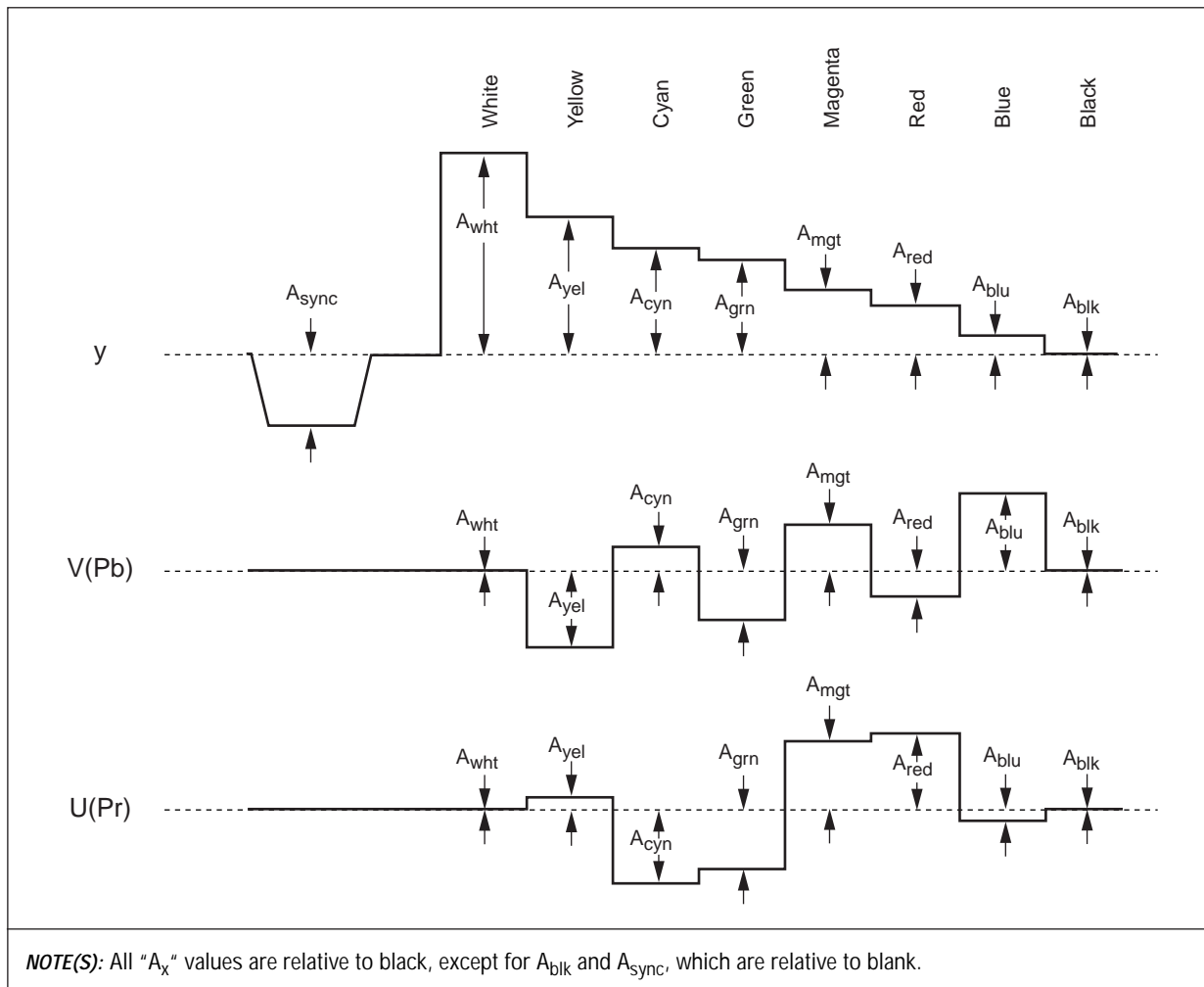

861_012

Table 3-5. 100/0/75/0 Colorbars as Described in EIA-770.1. EIA-770.1

	A _{sync} ⁽¹⁾	A _{wht}	A _{yel}	A _{cyn}	A _{grn}	A _{mgt}	A _{red}	A _{blu}	A _{blk} ⁽¹⁾
Y (volts)	-0.286	0.714	0.465	0.368	0.309	0.217	0.157	0.060	0
Pr (volts)	0	0	0.043	-0.262	-0.220	0.220	0.262	-0.043	0
Pb (volts)	0	0	-0.262	0.089	-0.174	0.174	-0.089	0.262	0

NOTE(S):
 (1) EIA-770.1 states that setup can be either "none or 7.5" IRE.
 If setup = 0, then A_{wht} = 714 V, but if setup = 7.5 IRE, then A_{wht} = 0.661 V.
 2. All "A_x" values are relative to black, except A_{blk}, and A_{sync} which are relative to blank.

Figure 3-13. RGB Video Format (Internal Colorbars)

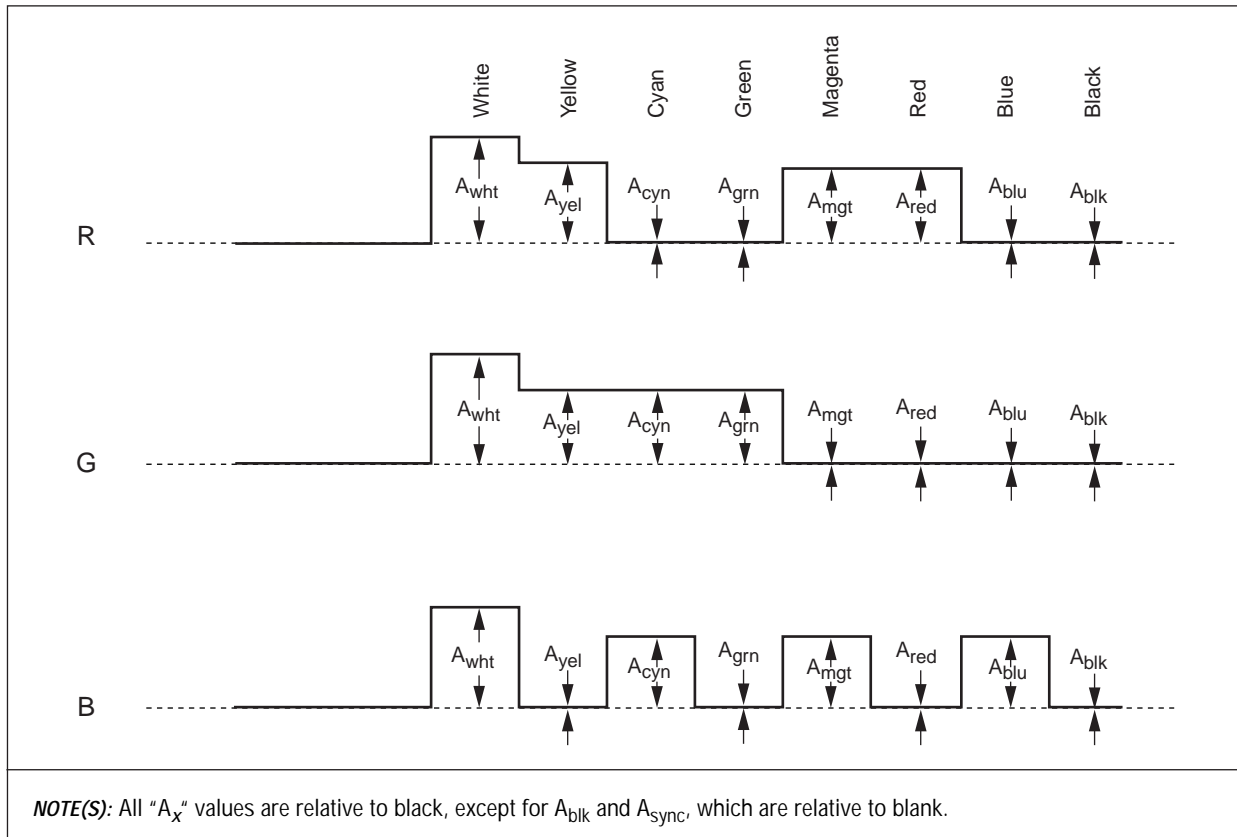

861_013

Table 3-6. 100/0/75/0 Colorbars for a 625-Line System

	A _{sync} ⁽¹⁾	A _{wht}	A _{yel}	A _{cyn}	A _{grn}	A _{mgt}	A _{red}	A _{blu}	A _{blk}
R (volts)	0	0.700	0.525	0	0	0.525	0.525	0	0
G (volts)	0	0.700	0.525	0.525	0.525	0	0	0	0
B (volts)	0	0.700	0	0.525	0	0.525	0	0.525	0

NOTE(S):

- (1) The Bt860/861 supports RGB that employs an external sync signal. For external sync, use the composite or S-Video luminance waveform.
- Complies with SMPTE 253.
- All "A_x" values are relative to black, except for A_{blk} and A_{sync} which are relative to blank.

Figure 3-14. Composite and S-Video Format (Internal Colorbars)

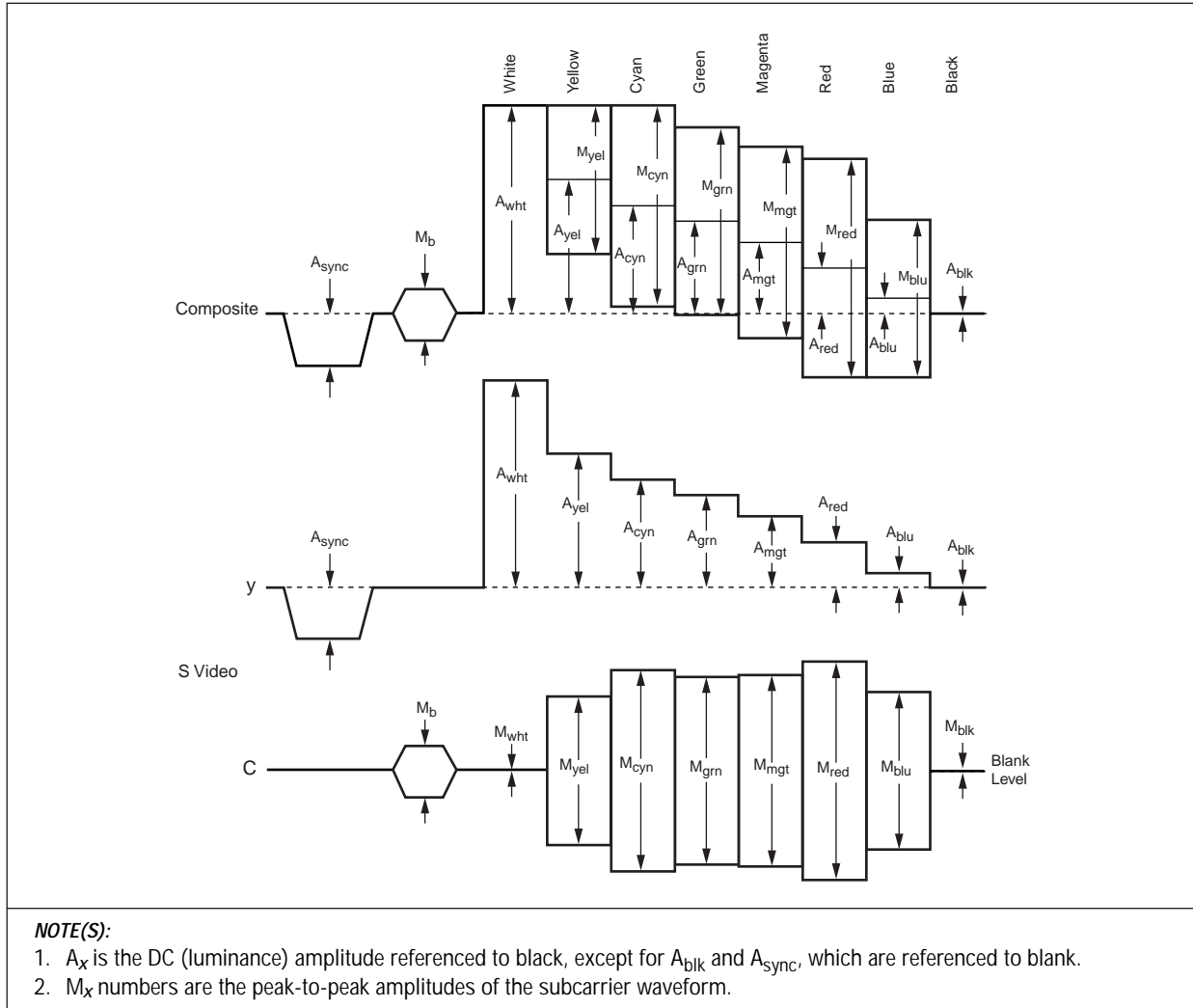

861_011

Table 3-7. Composite and Luminance Amplitude

Y and Composite Amplitudes	A_{sync}	A_{wht}	A_{yel}	A_{cyn}	A_{grn}	A_{mgt}	A_{red}	A_{blu}	A_{blk}
NTSC-M (volts)	-0.286	0.661	0.441	0.347	0.292	0.203	0.149	0.054	0.0536
NTSC-J (volts)	-0.286	0.714	0.477	0.375	0.316	0.220	0.161	0.059	0
PAL-B (volts)	-0.300	0.700	0.465	0.368	0.308	0.217	0.157	0.060	0

NOTE(S):
 A_x is the DC (luminance) amplitude referenced to black, except for A_{blk} and A_{sync} , which are referenced to blank.

Table 3-8. Composite and Chrominance Magnitude

C and Composite Magnitudes	M _b	M _{wht}	M _{yel}	M _{cyn}	M _{grn}	M _{mgt}	M _{red}	M _{blu}	M _{blk}
NTSC-M (volts)	0.286	0	0.444	0.630	0.589	0.589	0.629	0.444	0
NTSC-J (volts)	0.286	0	0.480	0.681	0.636	0.636	0.681	0.480	0
PAL-B (volts)	0.300	0	0.470	0.663	0.620	0.620	0.664	0.470	0

M_x numbers are the peak-to-peak amplitudes of the subcarrier waveform.

3.2.4 Setup

Setting the SETUP register bit to 1 places a 0.054 V (7.5 IRE) pedestal between blank and black. SETUP only affects Composite, Y of S-Video, Y of YUV, and RGB waveforms.

3.2.5 YUV and RGB Multipliers

When the output format of DACs D, E, and F is YUV or RGB, registers M_COMP_D (23[7:0]), M_COMP_E (25[7:0]) and M_COMP_F (24[7:0]) are amplitude multipliers. The gain range is from 0x to 2x, where a register value of 0x80 gives a gain of 1.

3.2.6 Programming Values to Comply with YPrPb and RGB

To comply with EIA 770.1 on 525-line systems for YPrPb values (listed in [Table 3-5](#)), start with the programming values listed in [Table 3-2](#), then use these multipliers:

Register	Value (NTSC-J)	Value (NTSC-M)
0x23	0x80	0x80
0x24	0x90	0x90
0x25	0x66	0x66

To attain the RGB values shown in [Table 3-6](#), start with the programming values listed in [Table 3-2](#), then use these multipliers:

Register	Value (PAL-B, D, G, H, I)
0x23	0x80
0x24	0x80
0x25	0x80

3.2.7 Programmable Video Adjustments Controls

Registers Y_OFF, M_Y, M_CB, M_CR, and PHASE_OFF program video adjustment controls for hue, brightness, contrast, saturation, and sharpness.

3.2.7.1 Hue Adjust

There are two methods for adjusting the hue. Only one method should be enabled at any time. While using one method, the registers of the other should be set to their default values.

Method 1—adjusts the subcarrier phase within the active video region. Register HUE_ADJUST (3B[7:0]) controls the subcarrier phase. This method adjusts the hue in composite and S-Video signals for PAL and NTSC waveforms according to the following equation:

$$HUE_ADJUST = 256 \times (\text{phase offset}) / 360^\circ$$

Method 2—uses the four registers MULT_UU, MULT_VU, MULT_UV, and MULT_VV to matrix multiply the color vectors.

These registers are used to perform a 2x2 matrix multiplication on the U/V path (or D_R/D_B path for SECAM). Matrix multiplication transforms the incoming U/V stream into an outgoing U/V stream preceding the color modulator. The default values leave the U/V stream unmodified. The parameters are 8-bit twos complement numbers.

The formulas implemented by these registers are as follows:

$$U_{out} = (MULT_UU/128) \times U_{in} + (MULT_VU/128) \times V_{in}$$

$$V_{out} = (MULT_UV/128) \times U_{in} + (MULT_VV/128) \times V_{in}$$

The value 0x7F is a special case which is rounded up internally to +128, or a factor of 1.00 after the multiplier is divided by 128.

These registers can be loaded with sine and cosine values as follows to perform a hue rotation on the chrominance values, except a value of +127 is made 128 internally.

To rotate the hue by an angle θ , program the matrix multipliers as follows:

$$MULT_UU = 128 \times \cos(\theta)$$

$$MULT_VU = -128 \times \sin(\theta)$$

$$MULT_UV = 128 \times \sin(\theta)$$

$$MULT_VV = 128 \times \cos(\theta)$$

Method 2 (matrix multiplication) cannot be used for hue rotation when the PAL bit is enabled. However, hue rotation can be accomplished for PAL modes in one of two ways. For component modes, method 2 hue rotation (matrix multiplication) is effective if register bit PAL (16[3]) is set to 0. For composite and S-Video modes, in which register bit PAL is enabled, method 1 hue rotation (subcarrier phase adjust) is effective. Hue rotation cannot be implemented simultaneously for component and composite PAL modes.

When in SECAM mode, this matrix multiplication occurs in D_R/D_B space, and, as a result, the angle should be the negative of what one would expect if the data was in the U/V space for PAL or NTSC.

3.2.7.2 Brightness Adjust

Brightness adjust is controlled by register Y_OFF (37[7:0]). Y_OFF is a twos complement number, such that a value of 0x00 is 0 IRE offset, a value of 0x7F is +22.14 IRE offset, and a value of 0x80 is -22.31 IRE offset. The luminance level offset is referenced from black and can be adjusted from -22.31 IRE (below black) to +22.14 IRE (above black). Active video is added to the offset level.

- 3.2.7.3 Contrast Adjust** Register M_Y (22[7:0]) controls contrast adjustment. This modifies the luminance multiplier, allowing a larger or smaller luminance range.
- 3.2.7.4 Saturation Adjust** Registers M_CB (21[7:0]) and M_CR (20[7:0]) control saturation adjustments. These registers are the chrominance component (Cb and Cr) multipliers. To maintain the correct Cb/Cr relationship, these registers should be modified synchronously.
- 3.2.7.5 Sharpness Adjust** Register field PKFIL_SEL (1B[4:3]) and register bit FIL_SEL (3C[2]) control sharpness filters. When FIL_SEL = 0, peaking filters of 0 dB, 1 dB, 2 dB and 3.5 dB gains are selected by register field PKFIL_SEL. When FIL_SEL = 1, four reduction filters are selected by register field PKFIL_SEL. [Figures 3-6](#) and [3-7](#) illustrates these filter options.

3.2.8 Macrovision Encoding (Bt861 Only)

The anticopy process contained within the Bt861 is implemented according to the version 7.x. Specification, developed by Macrovision Corporation in Sunnyvale, California. The Macrovision Anticopy process is available only in the Bt861. Conexant cannot ship Bt861 encoders to any customer until Macrovision has licensed that customer. Contact Macrovision Corporation to obtain this license agreement. Parties who have obtained a Macrovision license may receive the Bt861 Macrovision Supplement by contacting their local Conexant Sales office.

3.2.9 Outputs

Register field OUTMODE (17[5:3]) is used to select one of eight analog output configurations, as listed in [Table 3-9](#). All DACs are designed to drive standard video levels into a combined R_{load} of $37.5\ \Omega$ (double-terminated $75\ \Omega$). To minimize supply current, disable unused outputs by setting the corresponding DIS_DAC_x register bit high.

Table 3-9. DAC Format Options

Bits	DAC A	DAC B	DAC C	DAC D	DAC E	DAC F
000	Y	C	CVBS	Y	V	U
001	Y	C	CVBS	R	G	B
010	Y	C	CVBS	CVBS_DLY	CVBS	CVBS
011	Y	C	Y	Y	C	C
100	CVBS	CVBS_DLY	CVBS	Y	V	U
101	CVBS	CVBS_DLY	CVBS	R	G	B
110	CVBS	CVBS_DLY	CVBS	CVBS_DLY	CVBS	CVBS
111	Y	C	CVBS	CVBS_DLY	C	Y

NOTE(S): CVBS_DLY is the composite video signal with an optional luminance component delayed as controlled by the YDELAY register field.

3.2.10 Luminance Delay

Register field YDELAY can be programmed with up to 7 clocks delay on any DAC with a CVBS_DLY label (see [Table 3-9](#)). The programmable luminance delay can be used to correct the high frequency chrominance delay caused by postfiltering.

3.2.11 Special SCART Signals

At power-up, the ALTADDR pin is sampled to determine the Bt860/861's serial programming address. At all other times the SCART_SEL (3C[1:0]) register field determines its function. Setting the SCART_SEL register field to 00 will three-state the ALTADDR pin; setting it to 01 produces a Vertical Blank signal on the ALTADDR pin; setting it to 10 produces a Composite Sync signal on the ALTADDR pin; and setting it to 11 produces a Composite Blank signal on the ALTADDR pin. These signals are 3.3 V TTL signals that are aligned with the outgoing video, as illustrated in Figure 3-15.

Figure 3-15. SCART Function on ALTADDR Pin

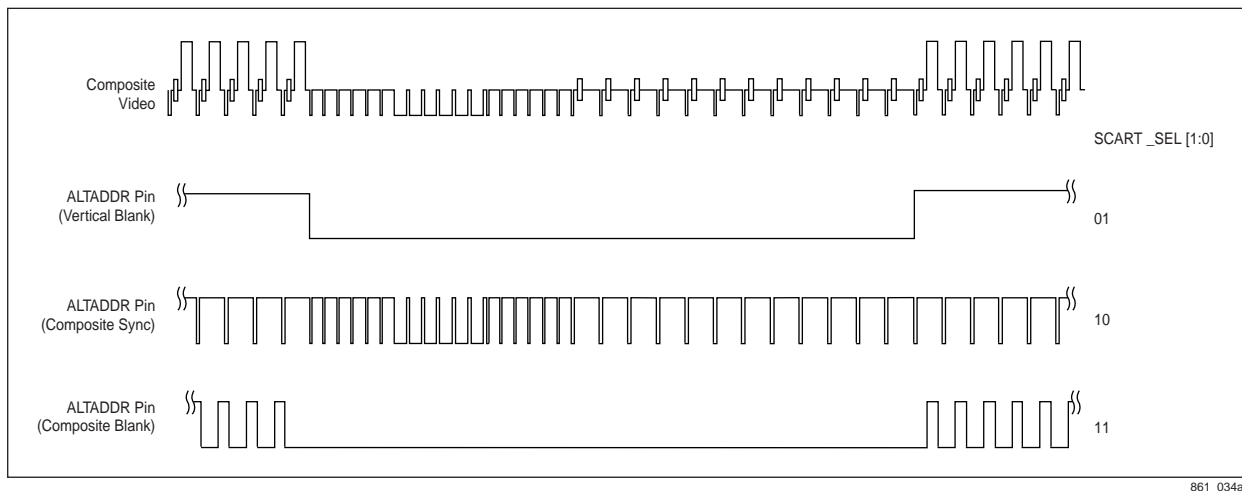

3.2.12 Output Connection Status

DAC connection status can be checked automatically or manually. When the AUTO_CHECK (1B[2]) register bit is set to 1, the connection status of the DACs is automatically checked once per frame. When the AUTO_CHECK register bit is set to 0 (default), setting the CHECK_STAT register bit to 1 initiates a single check of the DAC connection status. This bit is automatically cleared. The connection status of the DAC is then represented on the MONSTAT_A through MONSTAT_F register bits (01[7:2]). A 1 indicates that a properly terminated load has been detected on that DAC. Because the Bt860/861 checks for a double terminated load (combined 37.5 Ω), improper termination causes the load to be misrepresented. The DAC output must be enabled for proper sensing.

3.2.13 Output Filtering and SINX/X Compensation

The DAC output response is a typical $\sin x/x$ response. For the composite video output, this results in slightly lower than desired burst and chroma amplitude values. To compensate for this, choose an output filter with high frequency peaking or program the BST_AMP, M_CR, and M_CB registers higher by a factor of $(x/\sin x)$. The amplitude of the affected signal is calculated by:

$$Amplitude = \frac{\sin\left(\pi \cdot \frac{f_{sc}}{f_{clk}}\right)}{\left(\pi \cdot \frac{f_{sc}}{f_{clk}}\right)}$$

3.2.14 Low Power Features

The Bt860/Bt861 has several power saving features, including 3.3 V operation, individual DAC disable, sleep mode, and PLL disable.

The Bt860/861 is a 3.3 V part with 5 V-tolerant digital inputs; 5 V tolerance is obtained by setting the VDDMAX pin to 5 V. If 5 V tolerance is not required, connect VDDMAX to VDD.

Setting the SLEEP (1B[0]) register bit to 1 puts the part into sleep mode, in which all blocks are disabled except core serial programming functionality and the PLL. If CLKIN is the internal clock source, power can be further reduced by disabling the PLL and oscillator circuitry by setting the DIS_PLL (1D[4]) and DIS_XTAL (1D[7]) register bit to 1. In sleep mode, only the SLEEP bit is active, so the PLL must be powered down before sleep is induced if disabling the PLL is desired. This mode achieves the greatest reduction in power.

All DACs can be disabled individually using the EN_DAC_x (18[5:0]) register bits. This method can be used when not all DACs are required simultaneously.

3.2.15 Teletext Operation of Bt860/861

Teletext encoding in the Bt860/861 is accomplished via a two-wire interface, TTXDAT and TTXREQ, and several control registers, programmed via the serial programming interface. The Bt860/861 Teletext output conforms to Teletext B for 625-line systems; Teletext should be disabled for 525-line systems. For more details on the Teletext standard, consult ITU-R BT.653 or EACEM Technical Report No. 8.

The TTXDAT pin is the Teletext data insertion pin, and the TTXREQ pin is the timing pin. The TTXREQ pin can be configured into two Teletext timing modes by using register bit TXRM (59[1]). [Figure 3-16](#) illustrates Teletext timing.

Figure 3-16. Teletext Timing

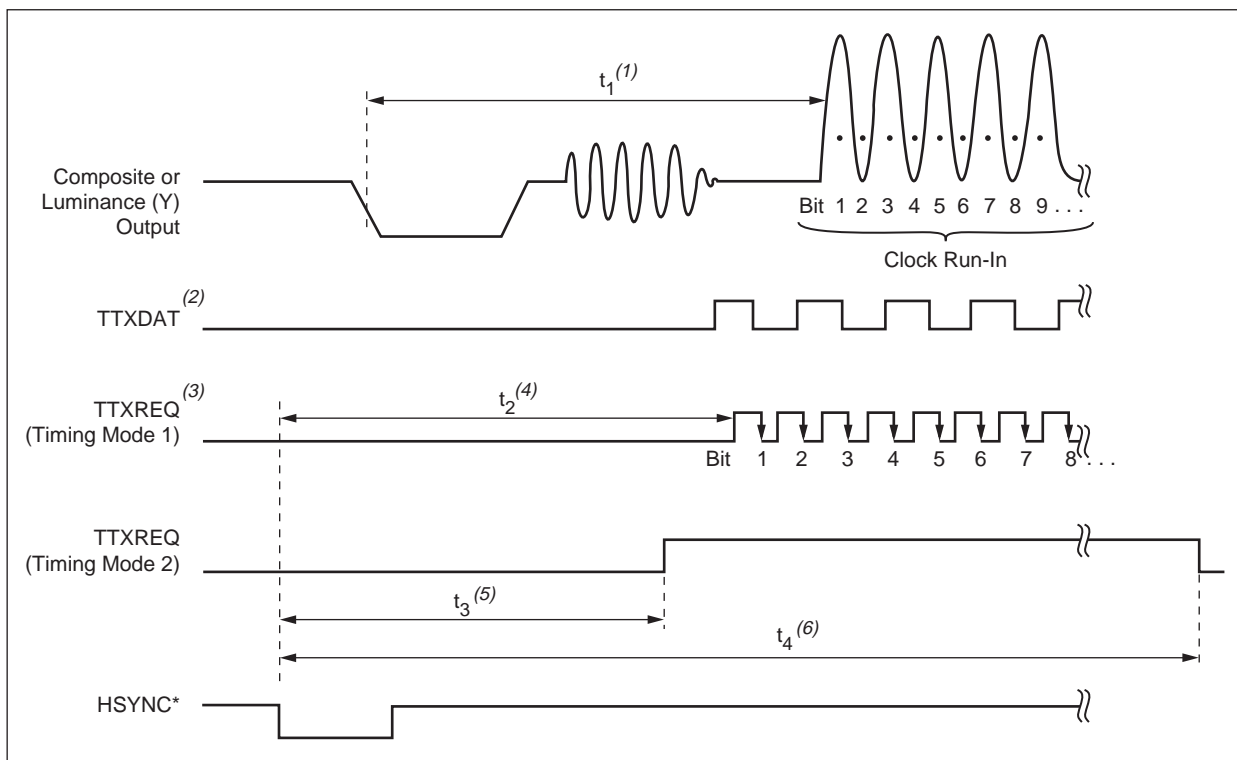

NOTE(S): (unchanged note)

- (1) t_1 is the start of Teletext. The midpoint of the first Teletext pulse is 10.2 μ s from the midpoint of the analog horizontal sync pulse falling edge.
- (2) The Teletext data on the TTXDAT pin must observe proper set-up and hold times relative to the Teletext timing clock falling edge (TTXREQ signal in timing mode 1).
- (3) Teletext data is latched on the Teletext timing clock's falling edge.
- (4) The Teletext timing clock's first rising edge (t_2) occurs 335 system clocks after falling HSYNC* for ITU-R BT.601 timing.
- (5) Placement of the rising edge of the TTXREQ request signal (t_3) in Teletext timing mode 2 is definable using register field TXHS[10:0].
- (6) Placement of the falling edge of the TTXREQ request signal (t_4) in Teletext timing mode 2 is definable using register field TXHE[10:0].

861_001

3.2.15.1 Teletext Timing Mode 1

Setting register bit TXRM to 1 puts the Bt860/861 in Teletext timing mode 1. In this mode, the TTXDAT pin is the Teletext data entry pin, and the TTXREQ pin is configured as the Teletext timing clock. The Teletext clock timing is fixed internally and has an average frequency of 6.9375 MHz. The Teletext timing clock does not have a consistent period, because it is derived from the system clock, which is not evenly divisible by 6.9375 MHz. The clock period varies from 3–4 system clocks for ITU-R BT.601 timing, and 4–5 system clocks for square pixel timing. Teletext data is latched on the falling edge of this clock. The first rising edge occurs 335 system clocks after falling HSYNC* for ITU-R BT.601 timing (27 MHz).

3.2.15.2 Teletext Timing Mode 2

Setting register bit TXRM to 0 puts the Bt860/861 in Teletext timing mode 2. In this mode, the TTXDAT pin is the Teletext data entry pin, and the TTXREQ pin is configured as the Teletext data request line. In this mode, the same Teletext timing clock as in mode 1 is fixed internally. The rising edge of the TTXREQ signal means start transmitting data, and the falling edge means stop transmitting data. The 11-bit register fields TTXHS[10:0] and TTXHE[10:0] control the placement of the rising and falling edges. Each LSB represents a one system clock count (27 MHz or 29.5 MHz) increment. When the system clock is 27 MHz, there is a 4 clock offset between the falling edge of HSYNC* and the rising or falling edge of the TTXREQ request signal. For example, a value of 0x001 on either register places the respective edge at 5 clocks from falling HSYNC*. The register values of TTXHS and TTXHE cannot be zero, equal to, or greater than the total number of system clocks per line.

The internal Teletext timing clock can be externally reproduced using a P:Q ratio counter, such as the one conceptualized in Figure 3-17. Table 3-10 lists appropriate values for ITU-R BT.601 and square pixel timing.

Figure 3-17. P:Q Ratio Counter Block Diagram

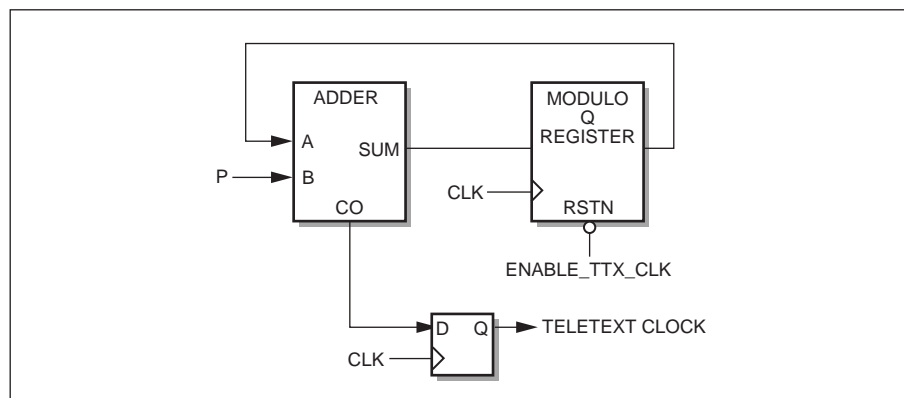

861_004

Table 3-10. P:Q Ratio Counter Values

	CLK	Pixel Rate	P	Q
ITU-R BT.601	27 MHz	13.5 MHz	37	144
Square Pixel	29.5 MHz	14.75 MHz	111	472

3.2.15.3 General Teletext Operation

A logical 1 on the TTXDAT pin corresponds to an analog output value of 66% of the black-to-white transition (approximately 462 mV above black), and a logical 0 corresponds to black.

The Bt860/861 does not automatically provide any Teletext data, such as the clock run-in and framing code; the user must provide all data.

Setting register bit TXE to 1 enables Teletext encoding. Register field TTXBF1[8:0] sets the start Teletext line for field 1, and register field TTXEF1[8:0] sets the end Teletext line for field 1. Register field TTXBF2 sets the start Teletext line for field 2, and register field TTXEF2[8:0] sets the end Teletext line for field 2. These 9-bit registers can be set to any value from 0–311, but setting the start line before line 7 is not recommended. The start line should be less than or equal to the end line. If the start and end lines for a field are the same value, Teletext is disabled for that field. Register bit SQUARE must be set to 0 for ITU-R BT.601 timing (27 MHz system clock), and 1 for square pixel timing (29 MHz system clock).

The TTX_DIS register field allows the user to disable the Teletext function on specific lines in the odd and even fields as listed in [Table 3-11](#).

Table 3-11. Teletext Line Disable

Register Bit	TTX Line (F1/F2)	Register Bit	TTX Line (F1/F2)
TTX_DIS[0]	8 / 321	TTX_DIS[8]	16 / 329
TTX_DIS[1]	9 / 322	TTX_DIS[9]	17 / 330
TTX_DIS[2]	10 / 323	TTX_DIS[10]	18 / 331
TTX_DIS[3]	11 / 324	TTX_DIS[11]	19 / 332
TTX_DIS[4]	12 / 325	TTX_DIS[12]	20 / 333
TTX_DIS[5]	13 / 326	TTX_DIS[13]	21 / 334
TTX_DIS[6]	14 / 327	TTX_DIS[14]	22 / 335
TTX_DIS[7]	15 / 328	TTX_DIS[15]	23 / 336

3.2.16 Wide Screen Signaling

Wide Screen Signaling (WSS) is used in 625-line systems on line 23. WSS data is 14 bits long and is entered on register bits WSS[14:1]. Register bits WSSDAT[20:15] are ignored. To enable WSS on field 1, line 23, set register bit EWSSF1 to 1. Register bit EWSSF2 is ignored, because WSS cannot be enabled on field 2. If the clock is at CCIR clock speeds (27 MHz), set register bit SQUARE to 0; if the clock is at square pixel speeds (29.5 MHz), set register bit SQUARE to 1. The clock run-in and start codes are automatically inserted onto the signal, but CRC data is not.

Figure 3-18 illustrates a typical WSS signal, where $WSSDAT[14:1] = 0x00$. Note that WSS uses bi-phase coding of its data bits. The amplitude of the WSS pulses is 500 mV above black when high, and black when low. For further WSS details, see specification *ETS 300294* or *ITU-R BT.1119*.

Figure 3-18. WSS Waveform

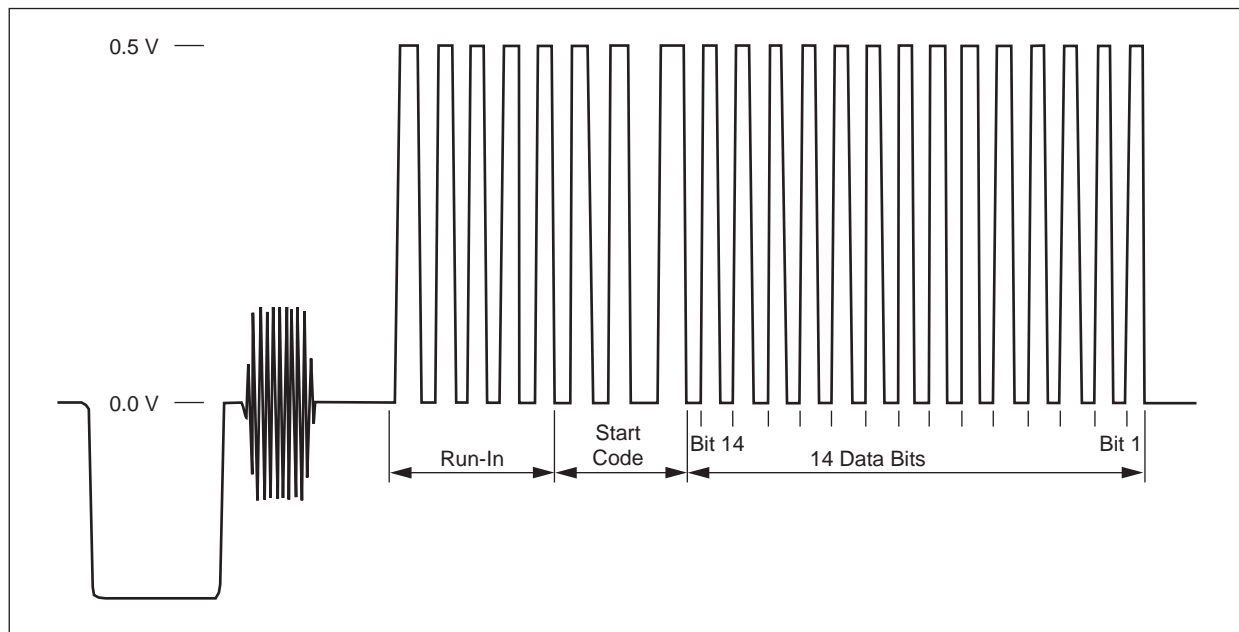

861_002

3.2.17 Copy Generation Management System

Copy Generation Management System (CGMS) is used in 525-line systems on lines 20 and 283 (a.k.a. line 20, field 2). The CGMS data is 20 bits long and is entered on register bits $WSSDAT[20:1]$.

- Set register bit EWSSF1 to 1 to enable CGMS on field 1, line 20.
- Set register bit EWSSF2 to 1 to enable CGMS on field 2, line 283.
- Set register bit SQUARE to 0 if the clock is at CCIR clock speeds (27 MHz).
- Set register bit SQUARE to 1 if the clock is at square pixel speeds (24.5454 MHz).

Although there is no clock run-in in CGMS, a reference pulse is provided automatically.

CRC data is not calculated and must be provided by the user. Figure 3-19 illustrates a typical CGMS signal. Note that bit 1 is closest to the HSYNC pulse and bit 20 is farthest. The amplitude of the CGMS pulses are 70 IRE when high, and 0 IRE when low. For further CGMS details, see specifications EIA-J CPR-1202, EIA-J CPR-1204, and IEC 61880.

Figure 3-19. CGMS Waveform

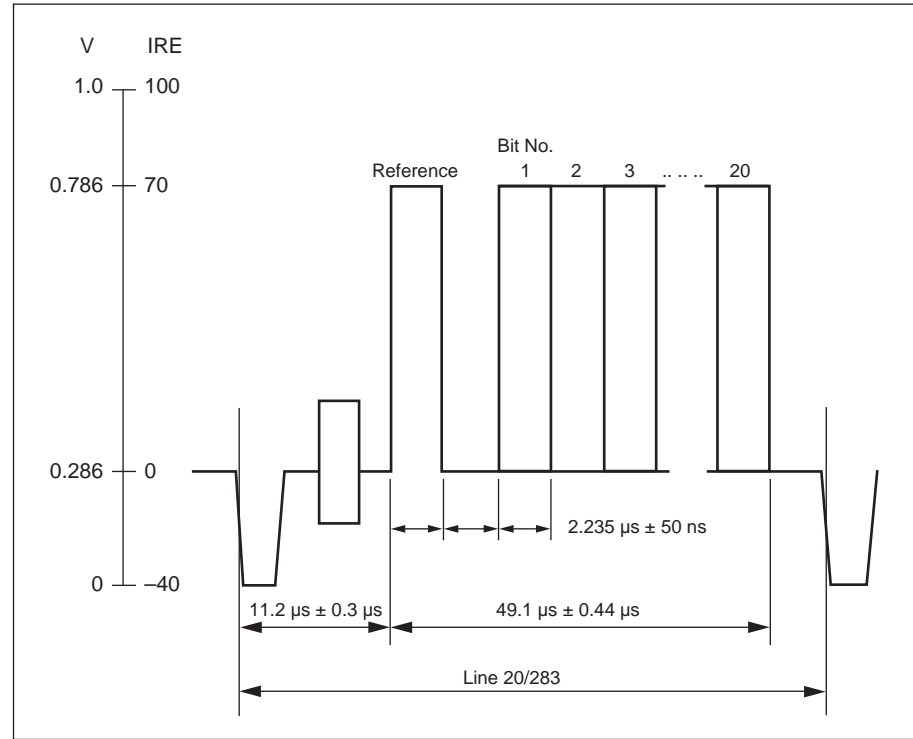

861_003

3.2.18 Closed Captioning and Extended Data Services

The Bt860/861 can produce Closed Captioning (CC) and Extended Data Services (XDS) waveforms for NTSC and PAL on the lines specified by CC_SEL (49[3:0]) and XDS_SEL (49[7:4]), as listed in Table 3-12. Two bytes of CC data are entered using registers CCB1 (42[7:0]) and CCB2(43[7:0]), and two bytes of XDS data are entered using registers XDSB1 (40[7:0]) and XDSB2 (41[7:0]). The data registers are double buffered to prevent accidental overwriting of the data. To enable CC, set register bit ECC (48[0]) high, and to enable XDS, set register bit EXDS (48[1]) high. To prevent writing partial data sequences, data is not latched until the second byte of the two-byte data sequence (CCB2 or XDSB2) is written. Therefore, data must be written in the order Byte 1, then Byte 2.

Table 3-12. Closed Captioning and Extended Data Services Control Bits

0x49	D7	D6	D5	D4	D3	D2	D1	D0
	XDS_SEL				CC_SEL			
525 Line	285	284	283	282	22	21	20	19
625 Line	336	335	334	333	24	23	22	21

The ECCGATE register bit must be 1 for normal operation. When this bit is set to 1, current data is displayed for one frame, and then the NULL data sequence is displayed until new data is written to the registers. If ECCGATE is set to 0, old data is displayed until new data is written to the registers.

Register bits CC_STAT (01[0]) and XDS_STAT (01[1]) allow monitoring of data latching and encoding. When CC data is latched into the Bt861 registers, the CC_STAT register bit is set to 1; when the data is encoded, it is set to 0. When XDS data is latched into the Bt861 registers, the XDS_STAT register bit is set to 1; when the data is encoded, it is set to 0.

By default, the CC or XDS waveform is placed at an appropriate start point and has a data frequency of 503.4965 kb/s, however, both the start point and signal width can be modified using registers fields CCSTART and CC_ADD, respectively. Figure 3-20 illustrates a typical CC or XDS waveform. The waveform consists of a clock run-in, a start bit, and two bytes of data, which is encoded LSB first. The Bt860/861 automatically creates the clock run-in and start bit, but does not calculate the parity bits. CC and XDS use an NRZ waveform, where a logical 0 is represented by a black, and a logical 1 is represented as 50 IRE. Pixel data is ignored during active CC and XDS lines, but the CC or XDS waveforms will be overwritten by Teletext data when Teletext is active on the CC or XDS line.

Figure 3-20. Closed Captioning or Extended Data Service Waveform (Null Sequence)

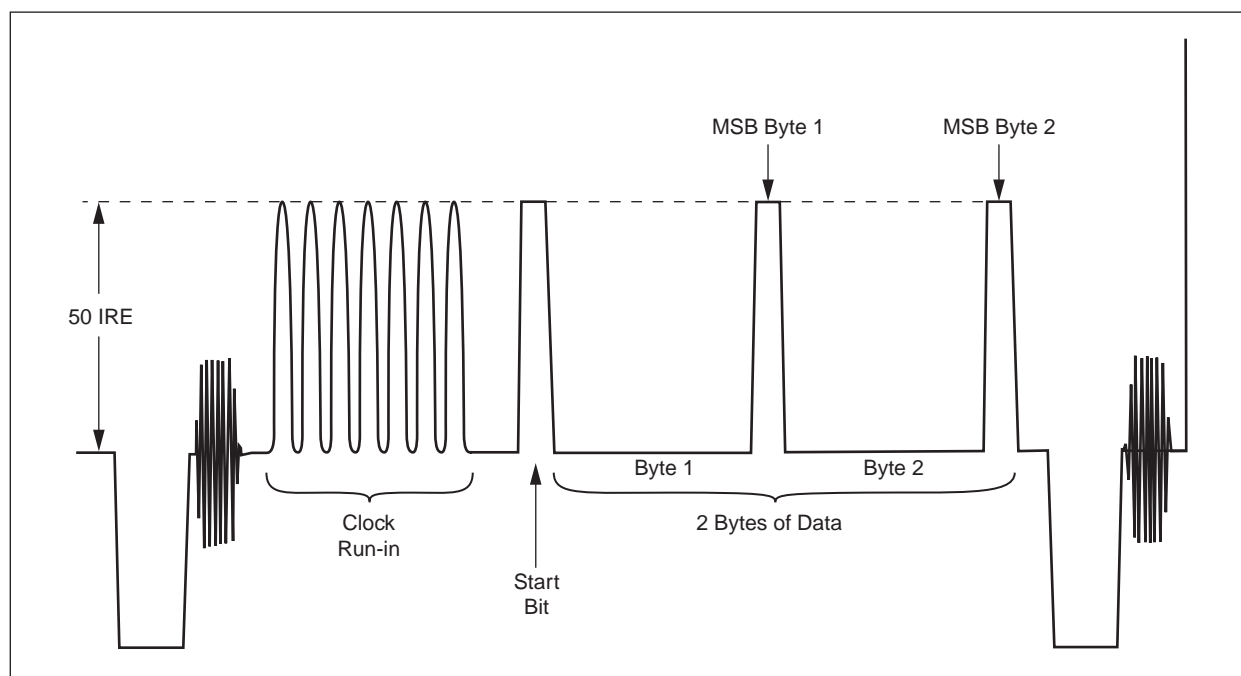

861_014

3.2.18.1 Closed Captioning Pass-through

There is no explicit means for accepting broadband vertical blanking interval (VBI) content through the data port. However, by expanding the active video region to include the CC line, the device can encode this data properly for output.

4.0 Applications

4.1 PC Board Considerations

The layout for the Bt860/861 should be optimized for the lowest noise possible on the power and ground planes by providing good decoupling. The trace length between groups of power and ground pins should be as short as possible to minimize inductive ringing. A well-designed power distribution network is critical for elimination of digital switching noise. The ground plane must provide a low-impedance return path for the digital circuits. A PC board with a minimum of four layers is recommended, with layers 1 (top) and 4 (bottom) for signals, and layers 2 and 3 for ground and power, respectively.

4.1.1 Component Placement

Components should be placed as close as possible to the associated pin so traces can be connected point-to-point. The optimum layout enables the Bt860/861 to be located close to both the power supply connector and video output connectors.

4.1.2 Power and Ground Planes

Separate digital and analog power planes are recommended as illustrated in [Figure 4-1](#). The digital power plane should provide power to all digital logic on the PC board, and the analog power plane should provide power to the VAA power pins, protection diodes, and COMP decoupling. There should be at least an 1/8-inch gap between the digital and analog power planes, connected by a single point through a ferrite bead. The ground plane should be a single unified plane overlapping both analog and digital power planes. The path back to the power supply should have the lowest impedance possible with only one possible return path. This layout eliminates noise on the analog signals caused by cross-currents from digital switching.

The bead separating the digital and analog power planes should be located within three inches of the Bt860/861. The bead provides impedance to switching currents and high frequency noise. Use a low-resistance ($<0.5 \Omega$) bead, such as Ferroxcube 5659065-3B, Fair-Rite 2723021447, or TDK BF45-4001.

Figure 4-1. Typical Connection Diagram

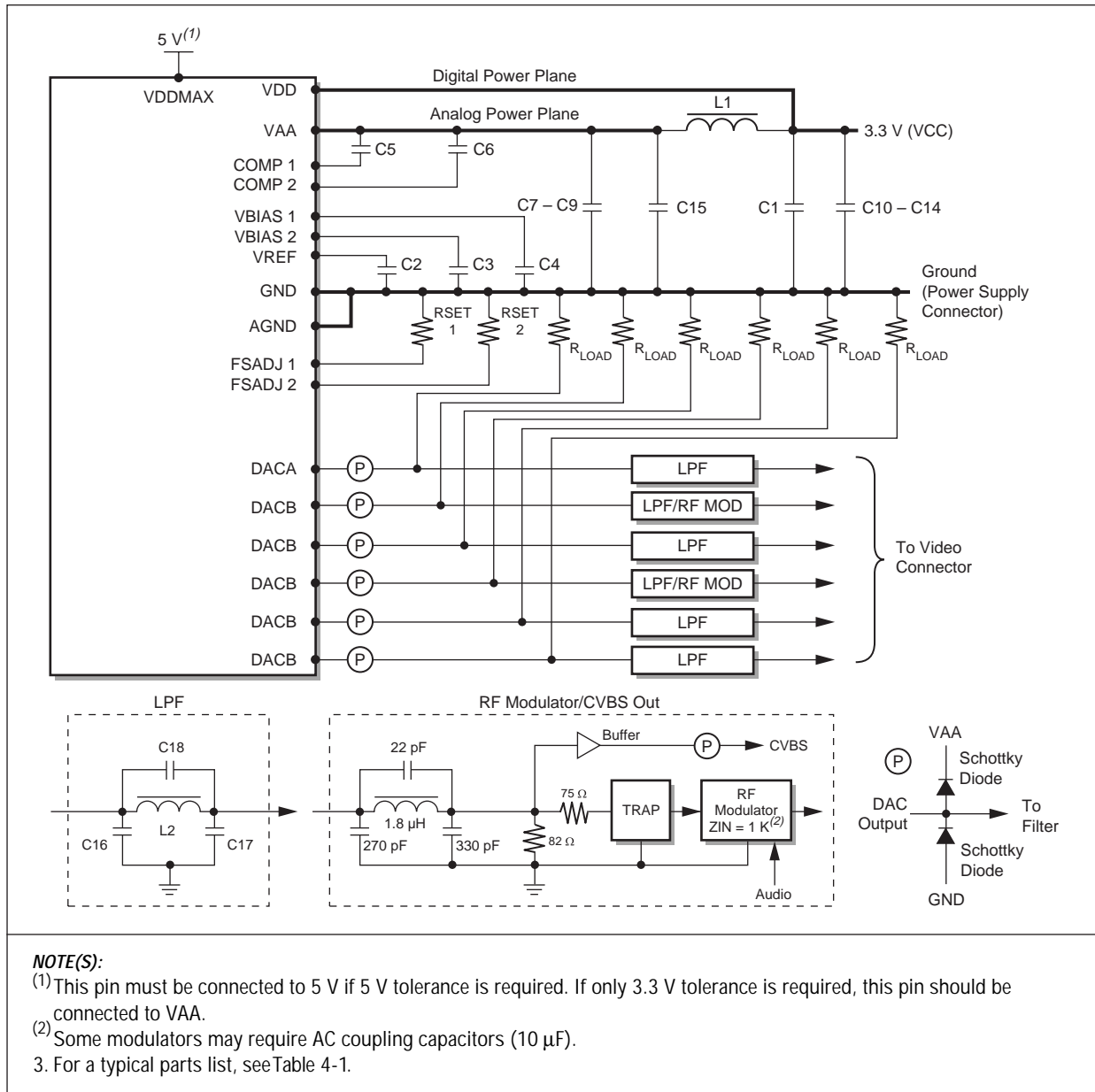

861_035

4.1.3 Device Decoupling

For optimum performance, all decoupling capacitors should be located as close as possible to the device, and the shortest possible leads should be used to reduce the lead inductance. Chip capacitors are recommended for minimum lead inductance. Radial lead ceramic capacitors can be substituted for chip capacitors and are better than axial lead capacitors for self-resonance. Values chosen have self-resonance above the pixel clock frequency.

4.1.4 Power Supply Decoupling

The best power supply performance is obtained with 0.1 μF ceramic capacitors decoupling each group of power pins to ground. Place the capacitors as close as possible to the device power pins and ground pins and connect with short, wide traces. Table 4-1 is a typical parts list.

The 47 μF capacitor illustrated in Figure 4-1 is for low-frequency power supply ripple; the 0.1 μF capacitors are for high-frequency power supply noise rejection.

A linear regulator is recommended to filter the analog power supply if the power supply noise is excessive. This is especially important when using a switching power supply.

Figure 4-2. Recommended Crystal Circuit

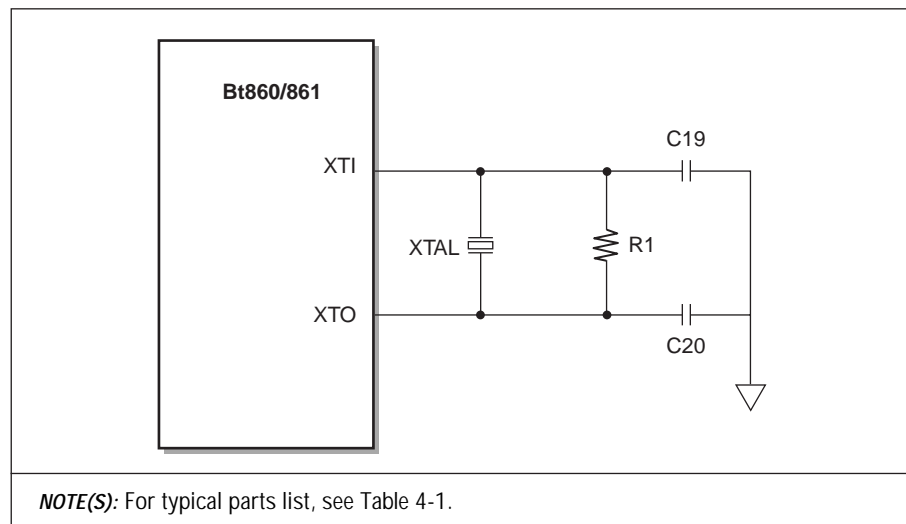

861_039

Table 4-1. Typical Parts List

Location	Description	Vendor	Part Number
C1, C15	47 μ F Capacitor	Mallory	CSR13F476KM
C16	5% 270 pF Ceramic Capacitor	AVX	08055A271JATMA
C17	5% 330 pF Ceramic Capacitor	AVX	08055A331JATMA
C18	5% 22 pF Ceramic Capacitor	AVX	08055A220JATMA
C19	5% 33 pF Ceramic Capacitor	AVX	08055A330JATMA
C2	20% 1.0 μ F Ceramic Capacitor	AVX	08053G105ZAT2A
C20	5% 27 pF Ceramic Capacitor	AVX	08055A270JATMA
C3–14	0.1 μ F Ceramic Capacitor	Erie	RPE112Z5U104M50V
L1	Ferrite Bead-Surface Mount	Fair-Rite	2743021447
L2	5% 1.8 μ H Inductor	KOA	KL32TEIR8J
P	Dual Schottky Diodes	HP	BAT54F
R1	1 M Ω Resistor	DALE	CRCW08051004FRT1
R _{load}	1% 75 Ω Metal Film Resistor	DALE	CRCW080575ROFRT1
RSET1, RSET2	1% 301 Ω Metal Film Resistor	Dale	CRCW08053010FRT1
TRAP	Ceramic Resonator	Murata	TPSx.xMJ (where x.x = sound carrier frequency in MHz)
XTAL	50 ppm, 14.31818 MHz Fundamental Crystal	Hooray	H1431818-18
NOTE(S): Vendor numbers are listed only as a guide. Substitution of devices with similar characteristics will not affect BT860/861 performance.			

4.1.5 COMP Decoupling

The COMP1 and COMP2 pins should be decoupled to the closest VAA pin with a 0.1 μ F ceramic capacitor. Greater low-frequency supply noise will require a larger value. The COMP1 and COMP2 capacitors must be as close as possible to the COMP1, COMP2, and VAA pins.

4.1.6 VREF Decoupling

A 1.0 μ F ceramic capacitor should be used to decouple VREF to AGND.

4.1.7 VBIAS Decoupling

A 0.1 μ F ceramic capacitor should be used to decouple VBIAS1 and VBIAS2 to AGND.

4.1.8 Digital Signal Interconnect

The digital inputs to the Bt860/861 should be isolated from the analog outputs and other analog circuitry as much as possible and should not overlay the analog power plane.

Most noise on the analog outputs is caused by excessive edge rates (less than 3 ns), overshoot, undershoot, and ringing on the digital inputs coupling into the analog signals. Ringing can be reduced by damping the line with a series resistor (30–300 Ω).

Because feed-through noise is proportional to the digital edge rates, lower-speed logic (3–5 ns edge rates) should be used whenever possible. Route the digital signals at 90-degree angles to any analog signals.

4.1.9 Analog Signal Interconnect

Locate the Bt860/861 as close as possible to the output connectors to minimize noise pickup and reflections caused by impedance mismatch. The video output signals should overlay the ground plane.

The analog outputs are susceptible to crosstalk from digital lines; digital traces must not be routed under or adjacent to the analog output traces.

For maximum performance, the analog video output impedance, cable impedance, and load impedance should be identical. The load resistor connection between the video outputs and AGND should be as close as possible to the Bt860/861 to minimize reflections. Turn off all unused analog outputs by setting the applicable EN_DAC_x register bit to 0.

4.1.10 ESD and Latchup Considerations

Correct ESD-sensitive handling procedures are required to prevent device damage, which can produce symptoms ranging from catastrophic failure to erratic device behavior with leaky inputs.

All logic inputs should be held low until power to the device has settled to the specified tolerance. DAC power decoupling networks with large time constants should be avoided; they could delay VAA and VDD power to the device. Ferrite beads must be used only for analog power VAA decoupling. Inductors cause a time constant delay that induces latchup, and should not be substituted for ferrite beads.

Latchup can be prevented by ensuring that all power pins are at the same potential, all GND pins are at the same potential, and that the VAA and VDD supply voltages are applied before the signal pin voltages. The correct power-up sequence ensures that any signal pin voltage will never exceed the power supply voltage.

5.0 Serial Programming Interface and Registers

5.1 Serial Interface

The Bt860/861 uses a 2-wire serial programming interface to program the device registers. The interface operates at 3.3 V or 5.0 V input levels. [Figure 5-1](#) illustrates the timing relationship between Serial Interface Data (SID) and Serial Interface Clock (SIC) lines. If the bus is not being used, both SID and SIC lines must be pulled high.

Figure 5-1. Serial Programming Interface Timing Diagram

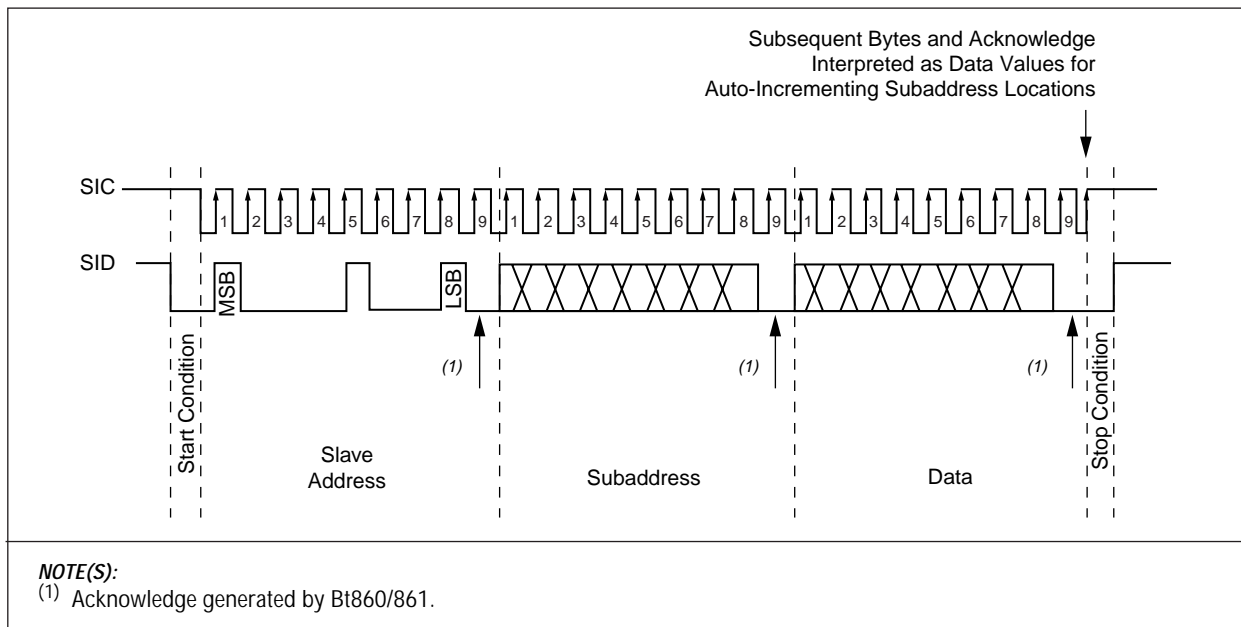

861_024

Every data word put onto the SID line must be 8 bits long (MSB first), followed by an acknowledge bit, generated by the receiving device. Each data transfer is initiated with a start condition and ended with a stop condition. The first byte after a start condition is always the slave address byte. If this is the device address, the device generates an acknowledge signal by pulling the SID line low during the ninth clock pulse.

The eighth bit of the address byte is the read/write* bit (high = read from the addressed device, low = write to the addressed device). Data bytes are always acknowledged during the ninth clock pulse by the addressed device.

NOTE: During the acknowledge period, the master device must leave the SID line high.

Premature termination of the data transfer is allowed by generating a stop condition at any time. When this happens, the Bt860/861 remains in the state defined by the last complete data byte transmitted, and any master acknowledge subsequent to reading the chip ID (subaddress 0x89) is ignored.

5.1.1 Device Address

The device address is configurable by the state of the ALTADDR pin at reset. If SCART functionality is not desired, the ALTADDR pin may be tied directly to power or ground to configure this address. Otherwise, the address should be configured through a soft-tie resistor to power or ground. [Table 5-1](#) lists how the ALTADDR pin configures the device address.

Table 5-1. Serial Address Configuration

ALTADDR	Device Address	Device Address Byte for Writes	Device Address Byte for Reads
0	7'b1000101	0x8A	0x8B
1	7'b1000100	0x88	0x89

5.1.2 Writing Data

A write transaction involves sending the device address byte with the read/write* bit low, and following it with one or more bytes. The first byte following the device address byte is always assumed to be a register subaddress, and sets an internal register subaddress pointer. This address is an 8-bit quantity, thus allowing the addressing of up to 256 byte-wide registers. If a second byte follows the device address byte, it is assumed to be the write data for the register indexed in the first byte. Any subsequent bytes are assumed to be write data for registers whose address follows in ascending order, as the internal subaddress pointer is incremented at the completion of each register write. The state of this internal address pointer upon exiting a write transaction is used for any read transactions that follow.

[Figure 5-2](#) illustrates a typical register write sequence.

1. Master transmits the device address with the read/write* bit low.
2. Master transmits the desired register subaddress.
3. Master transmits the register write data byte.
4. Subsequent registers are written until a stop condition is detected.

Figure 5-2. Serial Programming Interface Typical Write Sequence

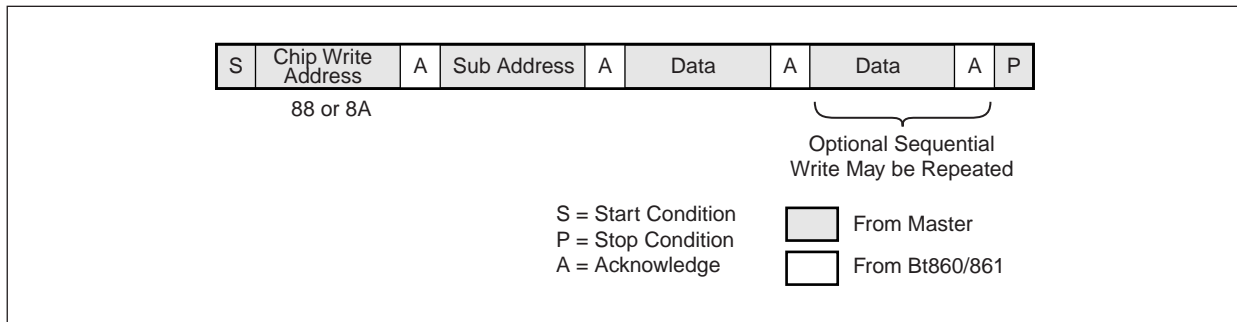

861_036

5.1.3 Reading Data

A read transaction involves sending the device address byte with the read/write* bit high, and receiving one or more bytes after changing the direction of the bus. The first byte returned after the device address byte is the contents of the last indexed register subaddress. Any subsequent data bytes read come from registers whose address follows in ascending order as the internal subaddress pointer is incremented at the completion of every read. The initial register subaddress depends on the state of the pointer at the end of the last write transaction. Because writing even one data byte to a register will increment the subaddress pointer, typically one would want to precede a read with a write transaction that sends only the register subaddress byte.

Figure 5-3 illustrates a typical register read sequence.

1. Master transmits the device address with the read/write* bit low.
2. Master transmits the desired register subaddress.
3. Master generates repeat start.
4. Master transmits the device address with the read/write* bit high.
5. Slave (Bt860/861) transmits the data byte to master.
6. Subsequent registers are read until a stop condition is detected.

Figure 5-3. Serial Programming Interface Typical Read Sequence

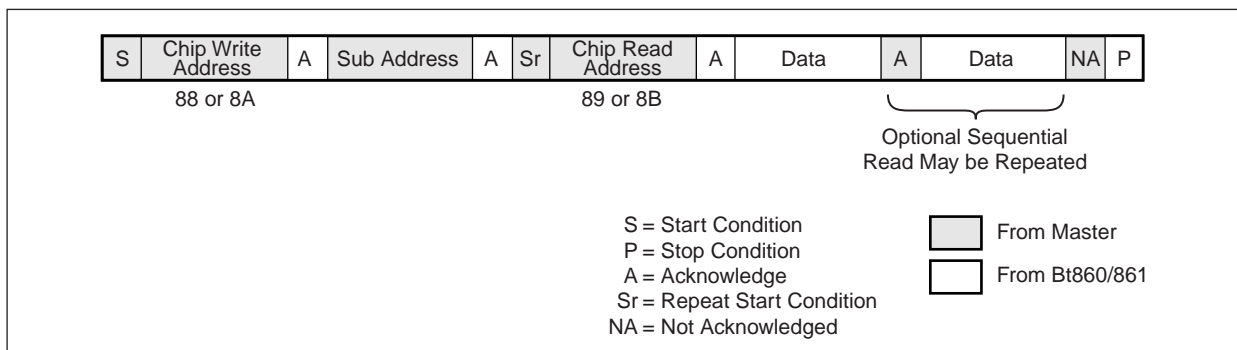

861_037

5.2 Internal Registers

Registers provide direct control and status of the part. These registers are accessed by the serial programming interface described in this section. [Table 5-2](#) provides a register bit map. [Table 5-3](#) lists the alpha-sorted register index. [Section 5.4](#) gives bit descriptions and detailed programming information. All registers are read/write unless otherwise indicated, and are set to default values following a software, power, and pin reset. A software reset is always performed at power-up, and when register bit SRESET (1B[7]) is set to 1.

5.2.1 Register Bit Map

Table 5-2. Register Bit Map (1 of 4)

Sub addr	Default Values ⁽¹⁾	D7	D6	D5	D4	D3	D2	D1	D0	
00 ⁽²⁾	4C or 0C	ID[1:0]		Reserved ⁽³⁾		VERSION[2:0]		Reserved ⁽³⁾		
01 ⁽²⁾	—	MONSTAT_F	MONSTAT_E	MONSTAT_D	MONSTAT_C	MONSTAT_B	MONSTAT_A	XDS_STAT	CC_STAT	
02 ⁽²⁾	—	FIELD_CNT[3:0]				VLOCK_ERR	PLL_LOCK	FIFO_UNDER	FIFO_OVER	
03 ⁽²⁾	00	Reserved ⁽³⁾								
04	B4	HCLK[7:0]								
05	06	Reserved ⁽⁴⁾				HCLK[11:8]				
06	C8	HACTIVE[7:0]								
07	02	Reserved ⁽⁴⁾						HACTIVE[9:8]		
08	7E	AHSYNC_WIDTH[7:0]								
09	90	HBURST_BEG[7:0]								
0A	54	HBURST_END[7:0]								
0B	0C	HBLANK[7:0]								
0C	01	Reserved ⁽⁴⁾						HBLANK[9:8]		
0D	13	VBLANK[7:0]								
0E	F1	VACTIVE[7:0]								
0F	00	Reserved ⁽⁴⁾							VACTIVE[8]	
10	00	HSYNC_OFF[7:0]								
11	00	Reserved ⁽⁴⁾						HSYNC_OFF[9:8]		
12	02	HSYNC_WIDTH[7:0]								
13	8C	PLL_FRACT[7:0]								
14	AF	PLL_FRACT[15:8]								

Table 5-2. Register Bit Map (2 of 4)

Sub addr	Default Values ⁽¹⁾	D7	D6	D5	D4	D3	D2	D1	D0	
15	0F	PLL_FRACT [18:16]			PLL_INT[4:0]					
16	10	SC_RESET	VSYNC_DUR	625LINE	SETUP	PAL	FM	NI	SLAVE	
17	10	CHROMA_BW	BLUE_FLD	OUTMODE[2:0]			DCHROMA	ECBAR	ECLIP	
18	3F	YDELAY[2:1]		EN_DAC_F	EN_DAC_E	EN_DAC_D	EN_DAC_C	EN_DAC_B	EN_DAC_A	
19	80	PCLK_SEL	VSYNCl	HSYNCl	FIELDI	BLANKI	BLK_IGNORE	PCLK_EDGE	FLDMODE	
1A	80	BLENDMODE	ALPHAMODE[1:0]		OVRLAY_SEL	VIDEO_SEL	EN_656	PROG_SC	SC_PATTERN	
1B	00	SRESET	FIELD_ID	CVBSD_INV	PKFIL_SEL[1:0]		AUTO_CHK	CHECK_STAT	SLEEP	
1C	C1	XL_VRI	LC_RST	LOCK	VIDVACTI	VIDHACTI	VIDFIELDI	VIDVALIDI	XL_LOCK	
1D	01	DIS_XTAL	DIS_SCADJ	SYNC_CFG	DIS_PLL	BY_PLL	CLKO_DIS	EACTIVE	CROSSFILT	
1E	E5	SYNC_AMP[7:0]								
1F	75	BURST_AMP[7:0]								
20	C1	M_CR[7:0]								
21	89	M_CB[7:0]								
22	9A	M_Y[7:0]								
23	80	M_COMP_D[7:0]								
24	80	M_COMP_F[7:0]								
25	80	M_COMP_E[7:0]								
26	1F	M_SC_DR[7:0]								
27	7C	M_SC_DR[15:8]								
28	F0	M_SC_DR[23:16]								
29	21	M_SC_DR[31:24]								
2A	13	M_SC_DB[7:0]								
2B	DA	M_SC_DB[15:8]								
2C	4B	M_SC_DB[23:16]								
2D	28	M_SC_DB[31:24]								
2E	85	SC_AMP[7:0]								
2F	A3	DR_MAX[7:0]								
30	05	Reserved ⁽⁴⁾					DR_MAX[10:8]			
31	9F	DR_MIN[7:0]								
32	04	Reserved ⁽⁴⁾					DR_MIN[10:8]			
33	A3	DB_MAX[7:0]								
34	05	Reserved ⁽⁴⁾					DB_MAX[10:8]			
35	9F	DB_MIN[7:0]								

Table 5-2. Register Bit Map (3 of 4)

Sub addr	Default Values ⁽¹⁾	D7	D6	D5	D4	D3	D2	D1	D0	
36	04	Reserved ⁽⁴⁾					DB_MIN[10:8]			
37	00	Y_OFF[7:0]								
38	00	PHASE_OFF[7:0]								
39	50	ALPHA_LUT_1[3:0]				ALPHA_LUT_0[3:0]				
3A	FA	ALPHA_LUT_3[3:0]				ALPHA_LUT_2[3:0]				
3B	00	HUE_ADJUST[7:0]								
3C	10	VIDCLK_EDGE	YDELAY[0]	XL_MDSEL[1:0]		XL_SATEN	FIL_SEL	SCART_SEL[1:0]		
3D–3F	00	Reserved								
40	80	XDSB1[7:0]								
41	80	XDSB2[7:0]								
42	80	CCB1[7:0]								
43	80	CCB2[7:0]								
44	4A	CCSTART[7:0]								
45	01	Reserved ⁽⁴⁾							CCSTART[8]	
46	8C	CCADD[7:0]								
47	09	Reserved ⁽⁴⁾				CCADD[11:8]				
48	00	Reserved ⁽⁴⁾					ECCGATE	EXDS	ECC	
49	44	XDSEL[3:0]				CCSEL[3:0]				
4A	—	EWSSF2	EWSSF1	Reserved ⁽⁴⁾	SQUARE	WSDAT[4:1]				
4B	—	WSDAT[12:5]								
4C	—	WSDAT[20:13]								
4D	39	TTXHS[7:0]								
4E	01	Reserved ⁽⁴⁾					TTXHS[10:8]			
4F	07	TTXHE[7:0]								
50	00	Reserved ⁽⁴⁾					TTXHE[10:8]			
51	00	TTXBF1[7:0]								
52	00	Reserved ⁽⁴⁾							TTXBF1[8]	
53	00	TTXEF1[7:0]								
54	00	Reserved ⁽⁴⁾							TTXEF1[8]	
55	00	TTXXBF2[7:0]								
56	00	Reserved ⁽⁴⁾							TTXXBF2[8]	
57	00	TTXEF2[7:0]								
58	00	Reserved ⁽⁴⁾							TTXEF2[8]	

Table 5-2. Register Bit Map (4 of 4)

Sub addr	Default Values ⁽¹⁾	D7	D6	D5	D4	D3	D2	D1	D0
59	02	Reserved ⁽⁴⁾						TXRM	TXE
5A	00	TTX_DIS[7:0]							
5B	00	TTX_DIS[15:8]							
5C	7F	MULT_UU[7:0]							
5D	0	MULT_VU[7:0]							
5E	0	MULT_UV[7:0]							
5F	7F	MULT_VV[7:0]							
60–6F	—	Reserved. Do not write to these registers.							
70	80	LC_FIFOWIN[7:0]							
71	01	Reserved ⁽⁴⁾							LC_FIFOWIN[8]
72	80	LC_MAXOFF[7:0]							
73	72	XL_GAIN[3:0]				XL_SAT[3:0]			
74–FF	00	Reserved. Do not write to these registers.							
NOTE(S): (1) Default values in this table are hexadecimal. (2) These registers are read only. (3) These bits return zero when read. (4) Reserved bits should be set to zero when written and will return zero when read.									

5.3 Register Index

Table 5-3. Register Index (1 of 5)

Field	Default Value ⁽¹⁾	Register	Description
625LINE	0	16[5]	Number of Lines per Frame
AHSYNC_WIDTH[7:0]	7E	08[7:0]	Analog Horizontal Sync Width
ALPHA_LUT_0[3:0]	0	39[3:0]	Alpha Blend Lookup Table Elements 0
ALPHA_LUT_1[3:0]	5	39[7:4]	Alpha Blend Lookup Table Elements 1
ALPHA_LUT_2[3:0]	A	3A[3:0]	Alpha Blend Lookup Table Elements 2
ALPHA_LUT_3[3:0]	F	3A[7:4]	Alpha Blend Lookup Table Elements 3
ALPHAMODE[1:0]	00	1A[6:5]	Alpha Select
AUTO_CHK	0	1B[2]	Automatic Monitor Status Checking
BLANKI	0	19[3]	BLANK * Polarity Control
BLENDDMODE	1	1A[7]	Blend Select
BLK_IGNORE	0	19[2]	BLANK Control
BLUE_FLD	0	17[6]	Blue Field
BURST_AMP[7:0]	75	1F[7:0]	Multiplication Factor for the Colorburst Amplitude for NTSC/PAL
BY_PLL	0	1D[3]	Bypass PLL
CC_STAT	—	01[0]	Closed Captioning Buffer Status
CCADD[11:0]	98C	47[3:0] 46[7:0]	Closed Captioning or Extended Data Services DTO Increment
CCB1[7:0]	80	42[7:0]	First Byte of Closed Captioning Information
CCB2[7:0]	80	43[7:0]	Second Byte of Closed Captioning Information
CCSEL[3:0]	4	49[3:0]	Line Position of Closed Captioning Content
CCSTART[8:0]	14A	45[0] 44[7:0]	Closed Captioning or Extended Data Services Start Placement
CHECK_STAT	—	1B[1]	Manual Monitor Status Checking
CHROMA_BW	0	17[7]	Chrominance Bandwidth
CLKO_DIS	0	1D[2]	CLKO Disable
CROSSFILT	1	1D[0]	SECAM Cross Color Filter
CVBSD_INV	0	1B[5]	Invert CVBS_DLY Outputs
DB_MAX[10:0]	5A3	34[2:0] 33[7:0]	Upper Boundary for Db Frequency Deviation in SECAM
DB_MIN[10:0]	49F	36[2:0] 35[7:0]	Lower Boundary for Db Frequency Deviation in SECAM
DCHROMA	0	17[2]	Disable Chrominance
DIS_PLL	0	1D[4]	Sleep PLL
DIS_SCADJ	0	1D[6]	Disable Automatic Subcarrier Adjust
DIS_XTAL	0	1D[7]	Disable Crystal Circuitry

Table 5-3. Register Index (2 of 5)

Field	Default Value ⁽¹⁾	Register	Description
DR_MAX[10:0]	5A3	30[2:0] 2F[7:0]	Upper Boundary for Dr Frequency Deviation in SECAM
DR_MIN[10:0]	49F	32[2:0] 31[7:0]	Lower Boundary for Dr Frequency Deviation in SECAM
EACTIVE	0	1D[1]	Enable Active Video
ECBAR	0	17[1]	Enable Internal Color Bars
ECC	0	48[0]	Enable Closed Captioning
ECCGATE	0	48[2]	Closed Captioning Gating
ECLIP	0	17[0]	Enable Clipping
EN_656	0	1A[2]	Enable 656 Code Translation
EN_DAC_A	1	18[0]	Enable DAC A
EN_DAC_B	1	18[1]	Enable DAC B
EN_DAC_C	1	18[2]	Enable DAC C
EN_DAC_D	1	18[3]	Enable DAC D
EN_DAC_E	1	18[4]	Enable DAC E
EN_DAC_F	1	18[5]	Enable DAC F
EWSSF1	0	4A[6]	Enable WSS or CGMS Function on Field 1
EWSSF2	0	4A[7]	Enable CGMS Function on Field 2
EXDS	0	48[1]	Enable Extended Data Services
FIELD_CNT[3:0]	—	02[7:4]	Field Number
FIELD_ID	0	1B[6]	Enable SECAM Bottleneck Pulses
FIELDI	0	19[4]	FIELD Polarity Control
FIFO_OVER	—	02[0]	FIFO Overflow Status
FIFO_UNDER	—	02[1]	FIFO Underflow Status
FIL_SEL	0	3C[2]	Filter Select
FLDMODE	0	19[0]	Field Tolerance
FM	0	16[2]	FM Modulation
HACTIVE[9:0]	2C8	07[1:0] 06[7:0]	Number of Active Pixels Per Line
HBLANK[9:0]	10C	0C[1:0] 0B[7:0]	Horizontal Blanking Length
HBURST_BEG[7:0]	90	09[7:0]	Beginning of Burst
HBURST_END[7:0]	54	0A[7:0]	End of Burst
HCLK[11:0]	6B4	05[3:0] 04[7:0]	Number of System Clocks Per Line
HSYNC_OFF[9:0]	000	11[1:0] 10[7:0]	HSYNC* Offset
HSYNC_WIDTH[7:0]	02	12[7:0]	HSYNC* Width
HSYNCI	0	19[5]	HSYNC* Polarity Control
HUE_ADJUST	00	3B[7:0]	Hue Adjustment by Subcarrier Shift
ID[1:0]	00 or 01	00[7:6]	Part Identification

Table 5-3. Register Index (3 of 5)

Field	Default Value ⁽¹⁾	Register	Description
LC_FIFOWIN[8:0]	180	71[0] 70[7:0]	FIFO Window
LC_MAXOFF[7:0]	80	72[7:0]	Max Adjustment
LC_RST	1	1C[6]	Locking Reset
LOCK	0	1C[5]	Start VID Path Locking
M_CB[7:0]	89	21[7:0]	Multiplication Factor for the Cb Component Prior to Modulation
M_COMP_D[7:0] M_COMP_F[7:0] M_COMP_E[7:0]	80	23[7:0] 24[7:0] 25[7:0]	Multiplication Factor for the Component at DAC D Multiplication Factor for the Component at DAC F Multiplication Factor for the Component at DAC E
M_CR[7:0]	C1	20[7:0]	Multiplication Factor for the Cr Component Prior to Modulation
M_SC_DB[31:0]	284BDA13	2D[7:0] 2C[7:0] 2B[7:0] 2A[7:0]	Subcarrier Increment for Db for SECAM
M_SC_DR[31:0]	21F07C1F	29[7:0] 28[7:0] 27[7:0] 26[7:0]	Subcarrier Increment for NTSC/PAL or Dr for SECAM
M_Y[7:0]	9A	22[7:0]	Luminance Multiplication Factor (contrast control)
MONSTAT_A MONSTAT_B MONSTAT_C MONSTAT_D MONSTAT_E MONSTAT_F	—	01[2] 01[3] 01[4] 01[5] 01[6] 01[7]	DAC A Connection Status DAC B Connection Status DAC C Connection Status DAC D Connection Status DAC E Connection Status DAC F Connection Status
MULT_UU	7F	5C[7:0]	Chrominance Matrix Multiplier
MULT_UV	00	5D[7:0]	Chrominance Matrix Multiplier
MULT_VU	00	5E[7:0]	Chrominance Matrix Multiplier
MULT_VV	7F	5F[7:0]	Chrominance Matrix Multiplier
NI	0	16[1]	Non-Interlace Enable
OUTMODE[2:0]	010	17[5:3]	DAC Output Format Control
OVRLAY_SEL	0	1A[4]	Overlay Select
PAL	0	16[3]	Phase Alternation
PCLK_EDGE	0	19[1]	Pixel Clock Edge Sample Select
PCLK_SEL	1	19[7]	Pixel Clock (system clock) Select
PHASE_OFF[7:0]	00	38[7:0]	Subcarrier Phase Offset (for SC – H Phase Adjustments)
PKFIL_SEL[1:0]	00	1B[4:3]	Luminance Peaking Filter Gain Selection
PLL_FRACT[18:0]	OAF8C	15[7:5] 14[7:0] 13[7:0]	Fractional Portion of the PLL Multiplier
PLL_INT[4:0]	0F	15[4:0]	Integer Portion of the PLL Multiplier
PLL_LOCK	1	02[2]	PLL Lock Status Bit
PROG_SC	0	1A[1]	SECAM Subcarrier Control

Table 5-3. Register Index (4 of 5)

Field	Default Value ⁽¹⁾	Register	Description
SC_AMP[7:0]	85	2E[7:0]	Multiplication Factor for the SECAM Subcarrier Amplitude
SC_PATTERN	0	1A[0]	SECAM Phase Sequence
SC_RESET	0	16[7]	Subcarrier Reset
SCART_SEL	00	3C[1:0]	SCART Selection Options
SETUP	1	16[4]	Setup
SLAVE	0	16[0]	Master/Slave Control
SLEEP	0	1B[0]	Sleep
SQUARE	0	4A[4]	Square Pixel or CCIR Timing Select for Teletext and WSS
SRESET	0	1B[7]	Software Reset
SYNC_AMP[7:0]	E5	1E[7:0]	Sync Tip to Blank Amplitude
SYNC_CFG	0	1D[5]	Sync Configuration
TTX_DIS[15:0]	0000	5B[7:0] 5A[7:0]	Teletext Disable by Line
TTXBF1[8:0]	000	52[0] 51[7:0]	Teletext Start Line for Field 1
TTXBF2[8:0]	000	56[0] 55[7:0]	Teletext Start Line for Field 2
TTXEF1[8:0]	000	54[0] 53[7:0]	Teletext End Line for Field 1
TTXEF2[8:0]	000	58[0] 57[7:0]	Teletext End Line for Field 2
TTXHE[10:0]	007	50[2:0] 4F[7:0]	TTXREQ Falling Edge
TTXHS[10:0]	139	4E[7:0] 4D[2:0]	TTXREQ Rising Edge
TXE	0	59[0]	Teletext Enable
TXRM	1	59[1]	TTXREQ Configuration
VACTIVE[8:0]	0F1	0F[0] 0E[7:0]	Number of Active Lines per Field
VBLANK[7:0]	13	0D[7:0]	Vertical Blanking Length
VERSION[2:0]	011	00[4:2]	Version Number for the Part
VIDCLK_EDGE	0	3C[7]	VIDCLK Edge Sample Select
VIDEO_SEL	0	1A[3]	Video Select
VIDFIELDI	0	1C[2]	VIDFIELD Polarity Control
VIDHACTI	0	1C[3]	VIDHACT Polarity Control
VIDVACTI	0	1C[4]	VIDVACT Polarity Control
VIDVALIDI	0	1C[1]	VIDVALID Polarity Control
VLOCK_ERR	—	02[3]	VID Port Locking Status
VSYNC_DUR	0	16[6]	Analog and Digital Vertical SYNC Duration
VSYNCI	0	19[6]	VSYNC* Polarity Control

Table 5-3. Register Index (5 of 5)

Field	Default Value ⁽¹⁾	Register	Description
WSDAT[20:1]	—	4C[7:0] 4B[7:0] 4A[3:0]	WSS and CGMS Data Bits
XDS_STAT	—	01[1]	Extended Data Services Buffer Status
XDSB1[7:0]	80	40[7:0]	First Byte of Extended Data Services Information
XDSB2[7:0]	80	41[7:0]	Second Byte of Extended Data Services Information
XDSSEL[3:0]	4	49[7:4]	Line Position of Extended Data Services Content
XL_GAIN[3:0]	7	73[7:4]	Accelerated Locking Gain
XL_LOCK	1	1C[0]	Accelerated Locking
XL_MDSEL[1:0]	01	3C[5:4]	Accelerated Locking Mode Select
XL_SAT[3:0]	2	73[3:0]	Accelerated Locking Saturation
XL_SATEN	0	3C[3]	Accelerated Locking Saturation Enable
XL_VRI	1	1C[7]	Accelerated Locking Vertical Realignment Initiation
Y_OFF[7:0]	00	37[7:0]	Luminance Level Offset (brightness control)
YDELAY[2:0]	000	18[7:6] 3C[6]	Luma Delay in 1/2 Pixel Increments for CVBS_DLY Outputs
<p>NOTE(S):</p> <p>(1) Default values in this table refer to hexadecimal values if the register field contains four or more bits; otherwise the value is binary.</p> <p>2. Internal timing and the values programmed into the registers reference the analog VSYNC pulse (O_V) as line #1 (see Figures 3-1 and 3-2).</p> <p>3. System clock = $F_{CLK} = 2x$ luminance sample frequency.</p>			

5.4 Register Detail

NOTE(S):

- (1) Internal timing and the values programmed into the registers reference the analog VSYNC pulse (O_V) as line #1 (see [Figures 3-1](#) and [3-2](#)).
2. System clock = $F_{CLK} = 2x$ luminance sample frequency.

Register 00

Register	Default Value	D7	D6	D5	D4	D3	D2	D1	D0
00	4C or 0C	ID[1:0]		Reserved	VERSION[2:0]			Reserved	
<p>This register is read only. Reserved bits return zero when read.</p> <p>ID[1:0] Part Identification 00 = Bt860 01 = Bt861</p> <p>VERSION[2:0] Version Number for the Part. Current version returns 011.</p>									

Register 01

Register	Default Value	D7	D6	D5	D4	D3	D2	D1	D0
01	—	MONSTAT_F	MONSTAT_E	MONSTAT_D	MONSTAT_C	MONSTAT_B	MONSTAT_A	XDS_STAT	CC_STAT
<p>This register is read only.</p> <p>MONSTAT_F DAC F Connection Status</p> <p>MONSTAT_E DAC E Connection Status</p> <p>MONSTAT_D DAC D Connection Status</p> <p>MONSTAT_C DAC C Connection Status</p> <p>MONSTAT_B DAC B Connection Status</p> <p>MONSTAT_A DAC A Connection Status 1 = Device connected to DAC output. 0 = No device connected to DAC output.</p> <p>XDS_STAT Extended Data Services Buffer Status 0 = Both XDSB1 and XDSB2 values have been encoded. 1 = Data has been written to the Extended Data Services registers and is not yet encoded.</p> <p>CC_STAT Closed Captioning Buffer Status 0 = Both CCB1 and CCB2 values have been encoded.</p>									

Register 02

Register	Default Value	D7	D6	D5	D4	D3	D2	D1	D0
02	04	FIELD_CNT[3:0]				VLOCK_ERR	PLL_LOCK	FIFO_UNDER	FIFO_OVER
<p>This register is read only.</p> <p>FIELD_CNT[3:0] Field Number 000 indicates the first field.</p> <p>VLOCK_ERR VID Port Locking Status High if VID port input frequency exceeds tracking range, as programmed by LC_MAXOFF.</p> <p>PLL_LOCK PLL Lock Status Bit 0 = Unable to lock to desired PLL frequency. 1 = PLL is able to lock to desired frequency.</p> <p>FIFO_UNDER FIFO Underflow Status High if VID port FIFO underflows. Resets to zero on write.</p> <p>FIFO_OVER FIFO Overflow Status High if VID port FIFO overflows. Resets to zero on write.</p>									

Register 04–05

Register	Default Value	D7	D6	D5	D4	D3	D2	D1	D0
04	B4	HCLK[7:0]							
05	06	Reserved				HCLK[11:8]			
<p>Reserved bits should be set to zero when written and will return zero when read.</p> <p>HCLK[11:0] Number of System Clocks Per Line</p>									

Register 06–07

Register	Default Value	D7	D6	D5	D4	D3	D2	D1	D0
06	C8	HACTIVE[7:0]							
07	02	Reserved						HACTIVE[9:8]	
<p>Reserved bits should be set to zero when written and will return zero when read.</p> <p>HACTIVE[9:0] Number of Active Pixels Per Line</p>									

Register 08

Register	Default Value	D7	D6	D5	D4	D3	D2	D1	D0
08	7E	AHSYNC_WIDTH[7:0]							
AHSYNC_WIDTH[7:0]		Analog Horizontal Sync Width Measured in system clock cycles, from 50% points of sync pulse.							

Register 09

Register	Default Value	D7	D6	D5	D4	D3	D2	D1	D0
09	90	HBURST_BEG[7:0]							
HBURST_BEG[7:0]		Beginning of Burst 50% point of burst from the 50% point of the analog horizontal sync falling edge, measured in system clock cycles.							

Register 0A

Register	Default Value	D7	D6	D5	D4	D3	D2	D1	D0
0A	54	HBURST_END[7:0]							
HBURST_END[7:0]		End of Burst 50% point of burst from the 50% point of the analog horizontal sync falling edge, measured in system clock cycles – 128.							

Register 0B–0C

Register	Default Value	D7	D6	D5	D4	D3	D2	D1	D0	
0B	0C	HBLANK[7:0]								
0C	01	Reserved						HBLANK[9:8]		
Reserved bits should be set to zero when written and will return zero when read.										
HBLANK[9:0]		<p>Horizontal Blanking Length</p> <p>Determines the number of system clocks between 50% point of the leading edge of the analog horizontal sync, as well as the relationship between the leading edge of the pulse on the HSYNC* pin and active video. If HBLANK is even, the relationship between the register and horizontal blanking in the encoded waveform is:</p> $HBLANK = (\text{desired horizontal blanking in system clocks}) + 14$ <p>If HBLANK is odd, the relationship is:</p> $HBLANK = (\text{desired horizontal blanking in system clocks}) + 15$ <p>Because, in either case you will get an even horizontal blanking in the encoded video waveform, the only reason for having an odd HBLANK value is to align the active video window with the encoding data stream. The relationship between HBLANK and the position of active video on the P, OSD, and ALPHA pins is:</p> $HBLANK = [(\text{HSYNC* pin to active video}) + 2 + HSYNC_OFF] \quad \text{master mode}$ $HBLANK = [(\text{HSYNC* pin to active video}) + 3] \quad \text{slave mode BLK_IGNORE bit} = 1$								

Register 0D

Register	Default Value	D7	D6	D5	D4	D3	D2	D1	D0
0D	13	VBLANK[7:0]							
VBLANK[7:0]		<p>Vertical Blanking Length</p> <p>Line number of first active line (number of blank lines + 1), measured from (0_V) vertical sync⁽¹⁾.</p>							

Register 0E–0F

Register	Default Value	D7	D6	D5	D4	D3	D2	D1	D0	
0E	F1	VACTIVE[7:0]								
0F	00	Reserved						VACTIVE[8]		
Reserved bits should be set to zero when written and will return zero when read.										
VACTIVE[8:0]		Number of Active Lines per Field								

Register 10–11

Register	Default Value	D7	D6	D5	D4	D3	D2	D1	D0	
10	00	HSYNC_OFF[7:0]								
11	00	Reserved						HSYNC_OFF[9:8]		
<p>Reserved bits should be set to zero when written and will return zero when read.</p> <p>HSYNC_OFF[9:0] HSYNC* Offset</p> <p>Defines the offset in system clocks of HSYNC* pulse relative to the internal horizontal sync in master mode.</p> <p>This value is twos complement so that:</p> <p>000 = 0 clock delay 1FF = 2047 clock delay 200 = 2048 clock advance 3FF = 1 clock advance</p>										

Register 12

Register	Default Value	D7	D6	D5	D4	D3	D2	D1	D0
12	02	HSYNC_WIDTH[7:0]							
<p>HSYNC_WIDTH[7:0] HSYNC* Width</p> <p>Width in system clocks of HSYNC* pulse in master mode.</p>									

Register 13–15

Register	Default Value	D7	D6	D5	D4	D3	D2	D1	D0
13	8C	PLL_FRACT[7:0]							
14	AF	PLL_FRACT[15:8]							
15	0F	PLL_FRACT [18:16]				PLL_INT[4:0]			
<p>PLL_FRACT[18:0] Fractional Portion of the PLL Multiplier</p> <p>PLL_INT[4:0] Integer Portion of the PLL Multiplier</p> <p>The range of the PLL multiplier is from 0.0 to 3.999999, and the minimum adjustment is $1.90734863 \times 10^{-6}$.</p> <p>The equation to derive PLL frequency is:</p> $\text{Desired PLL frequency} = [(XTAL \text{ freq} / 8) \times (PLL_INT + (PLL_FRACT / 2^{19}))]$									

Register 16

Register	Default Value	D7	D6	D5	D4	D3	D2	D1	D0
16	10	SC_RESET	VSYNC_DUR	625LINE	SETUP	PAL	FM	NI	SLAVE
SC_RESET		Subcarrier Reset 0 = Subcarrier phase reset at beginning of each color field sequence. 1 = Disable subcarrier reset.							
VSYNC_DUR		Analog and Digital Vertical Sync Duration Specifies the duration of the digital vertical sync pulse and the duration of the analog pre-equalization, post-equalization, and serration pulses. 0 = 3 lines. 1 = 2.5 lines.							
625LINE		Number of Lines per Frame 0 = 525-line format. 1 = 625-line format.							
SETUP		Setup 0 = 7.5 IRE setup disabled. 1 = 7.5 IRE setup enabled.							
PAL		Phase Alternation 0 = Disable phase alternation (NTSC and SECAM). 1 = Enable phase alternation (PAL).							
FM		FM Modulation 0 = QAM chroma encoding (NTSC/PAL). 1 = FM chroma encoding (SECAM).							
NI		Non-Interlace Enable 0 = Interlaced field operation. 1 = Non-interlaced field operation.							
SLAVE		Master/Slave Control 0 = Generate video timing for other devices (master mode). 1 = Accept video timing from other devices (slave mode). (See also register bits EN656 and SYNC_CFG.)							

Register 17

Register	Default Value	D7	D6	D5	D4	D3	D2	D1	D0																																																															
17	10	CHROMA_BW	BLUE_FLD	OUTMODE[2:0]			DCHROMA	ECBAR	ECLIP																																																															
CHROMA_BW		Chrominance Bandwidth 0 = Normal chroma bandwidth. 1 = Wide chroma bandwidth. See filter plots in Section 3.2.2																																																																						
BLUE_FLD		Blue Field 0 = Normal operation. 1 = Generate blue field.																																																																						
OUTMODE[2:0]		DAC Output Format Control Controls format output on each DAC, as listed in the following table.																																																																						
		<table border="1"> <thead> <tr> <th>Bits</th> <th>DAC A</th> <th>DAC B</th> <th>DAC C</th> <th>DAC D</th> <th>DAC E</th> <th>DAC F</th> </tr> </thead> <tbody> <tr> <td>000</td> <td>Y</td> <td>C</td> <td>CVBS</td> <td>Y</td> <td>V</td> <td>U</td> </tr> <tr> <td>001</td> <td>Y</td> <td>C</td> <td>CVBS</td> <td>R</td> <td>G</td> <td>B</td> </tr> <tr> <td>010</td> <td>Y</td> <td>C</td> <td>CVBS</td> <td>CVBS_DLY</td> <td>CVBS</td> <td>CVBS</td> </tr> <tr> <td>011</td> <td>Y</td> <td>C</td> <td>Y</td> <td>Y</td> <td>C</td> <td>C</td> </tr> <tr> <td>100</td> <td>CVBS</td> <td>CVBS_DLY</td> <td>CVBS</td> <td>Y</td> <td>V</td> <td>U</td> </tr> <tr> <td>101</td> <td>CVBS</td> <td>CVBS_DLY</td> <td>CVBS</td> <td>R</td> <td>G</td> <td>B</td> </tr> <tr> <td>110</td> <td>CVBS</td> <td>CVBS_DLY</td> <td>CVBS</td> <td>CVBS_DLY</td> <td>CVBS</td> <td>CVBS</td> </tr> <tr> <td>111</td> <td>Y</td> <td>C</td> <td>CVBS</td> <td>CVBS_DLY</td> <td>C</td> <td>Y</td> </tr> </tbody> </table>								Bits	DAC A	DAC B	DAC C	DAC D	DAC E	DAC F	000	Y	C	CVBS	Y	V	U	001	Y	C	CVBS	R	G	B	010	Y	C	CVBS	CVBS_DLY	CVBS	CVBS	011	Y	C	Y	Y	C	C	100	CVBS	CVBS_DLY	CVBS	Y	V	U	101	CVBS	CVBS_DLY	CVBS	R	G	B	110	CVBS	CVBS_DLY	CVBS	CVBS_DLY	CVBS	CVBS	111	Y	C	CVBS	CVBS_DLY	C	Y
Bits	DAC A	DAC B	DAC C	DAC D	DAC E	DAC F																																																																		
000	Y	C	CVBS	Y	V	U																																																																		
001	Y	C	CVBS	R	G	B																																																																		
010	Y	C	CVBS	CVBS_DLY	CVBS	CVBS																																																																		
011	Y	C	Y	Y	C	C																																																																		
100	CVBS	CVBS_DLY	CVBS	Y	V	U																																																																		
101	CVBS	CVBS_DLY	CVBS	R	G	B																																																																		
110	CVBS	CVBS_DLY	CVBS	CVBS_DLY	CVBS	CVBS																																																																		
111	Y	C	CVBS	CVBS_DLY	C	Y																																																																		
		NOTE(S): CVBS_DLY is the composite video signal with the luminance component delayed as controlled by YDELAY.																																																																						
DCHROMA		Disable Chrominance 0 = Normal operation. 1 = Disable chroma components.																																																																						
ECBAR		Enable Internal Color Bars 0 = Normal operation. 1 = Enable color bars. See colorbar plots in Section 3.2.3 .																																																																						
ECLIP		Enable Clipping 0 = Normal operation. 1 = Enable clipping. DAC values less than 64 are made 63. This limit corresponds to roughly one-fourth of the sync height.																																																																						

Register 18

Register	Default Value	D7	D6	D5	D4	D3	D2	D1	D0
18	3F	YDELAY[2:1]		EN_DAC_F	EN_DAC_E	EN_DAC_D	EN_DAC_C	EN_DAC_B	EN_DAC_A
YDELAY[2:1]		MSBs of Luma Delay in Pixels for CVBS_DLY Outputs YDELAY[0] is in 1/2 pixel increments, at 3C[6]. 00 = No delay. 01 = Delay 1 pixel. 10 = Delay 2 pixels. 11 = Delay 3 pixels.							
EN_DAC_F		Enable DAC F							
EN_DAC_E		Enable DAC E							
EN_DAC_D		Enable DAC D							
EN_DAC_C		Enable DAC C							
EN_DAC_B		Enable DAC B							
EN_DAC_A		Enable DAC A 0 = Disable individual DAC output. 1 = Enable individual DAC output.							

Register 19

Register	Default Value	D7	D6	D5	D4	D3	D2	D1	D0
19	80	PCLK_SEL	VSYNCI	HSYNCI	FIELDI	BLANKI	BLK_IGNORE	PCLK_EDGE	FLDMODE
PCLK_SEL		Pixel Clock (system clock) Select State of FIELD pin during power-up determines the default value of PCLK_SEL. FIELD = 1 corresponds to PCLK_SEL = 0 as default, while FIELD = 0 corresponds to PCLK_SEL = 1 as default. If FIELD is not externally loaded, an internal pull-down sets FIELD = 0 at power-up. 0 = Use CLKIN as pixel clock source. 1 = Use PLL as pixel source (derived from XTI and XTO inputs).							
VSYNCI		VSYNC* Polarity Control 0 = Active low VSYNC* pin. 1 = Active high VSYNC* pin.							
HSYNCI		HSYNC* Polarity Control 0 = Active low HSYNC* pin. 1 = Active high HSYNC* pin.							
FIELDI		FIELD Polarity Control 0 = A 1 on FIELD pin indicates an even field. 1 = A 1 on FIELD pin indicates an odd field.							
BLANKI		BLANK* Polarity Control 0 = Active low BLANK* pin. 1 = Active high BLANK* pin.							
BLK_IGNORE		Blank Control 0 = Use BLANK* pin to indicate the active pixel region in slave mode. 1 = Use HBLANK, HACTIVE, VACTIVE, and VBLANK registers to determine the active pixel region in slave mode.							
PCLK_EDGE		Pixel Clock Edge Sample Select 0 = P, OSD, ALPHA, HSYNC*, VSYNC*, BLANK* data sampled at the rising edge of the system clock. 1 = P, OSD, ALPHA, HSYNC*, VSYNC*, BLANK* data sampled at the falling edge of the system clock.							
FLDMODE		Field Tolerance 0 = A falling edge of VSYNC* that occurs within $\pm 1/4$ of a scan line from the falling edge of HSYNC* indicates the beginning of odd field. A falling edge of VSYNC* that occurs within $\pm 1/4$ scan line from the center of the line indicates the beginning of even field. 1 = A falling edge of VSYNC* that occurs during HSYNC* high indicates the beginning of odd field. A falling edge of VSYNC* that occurs during HSYNC* low indicates the beginning of even field.							

Register 1A

Register	Default Value	D7	D6	D5	D4	D3	D2	D1	D0
1A	80	BLENDMODE	ALPHAMODE[1:0]		OVRLAY_SEL	VIDEO_SEL	EN_656	PROG_SC	SC_PATTERN
BLENDMODE		Blend Select 0 = Alpha control contained in Y[1:0] of port selected by OVRLAY_SEL. 1 = Alpha control contained in ALPHA[1:0] pins as described by ALPHAMODE [1:0] bits. See Table 2-1 .							
ALPHAMODE[1:0]		Alpha Select (effective only when BLENDMODE = 1) 00 = Disable Alpha blending. 01 = Use ALPHA[0] as 1-bit alpha blend value with look-up table value. 10 = Use ALPHA[1:0] as 2-bit alpha blend value with look-up table value. 11 = Use ALPHA[1:0] over two load clocks to form a 4-bit alpha blend value. See Table 2-1 and Figure 2-2 .							
OVRLAY_SEL		Overlay Select 0 = Select P[7:0] as overlay blend stream. 1 = Select OSD[7:0] as overlay blend stream. See Table 2-1 .							
VIDEO_SEL		Video Select 0 = Select P[7:0] as video blend stream. 1 = Select VID[7:0] as video blend stream. See Table 2-1 .							
EN_656		Enable 656 Code Translation 0 = Use HSYNC*, VSYNC*, and BLANK* for video timing information. 1 = Use embedded SAV/EAV codes as defined by ITU-R BT.656 specification from port P[7:0] as timing source. See Table 2-2 .							
PROG_SC		SECAM Subcarrier Control 0 = SECAM subcarrier is generated on lines 23–310 and 336–623. 1 = SECAM subcarrier is generated on the active lines defined by VBLANK and VACTIVE.							
SC_PATTERN		SECAM Phase Sequence 0 = 0° 0° 180° 0° 0° 180° SECAM subcarrier phase sequence. 1 = 0° 0° 0° 180° 180° 180° SECAM subcarrier phase sequence.							

Register 1B

Register	Default Value	D7	D6	D5	D4	D3	D2	D1	D0
1B	00	SRESET	FIELD_ID	CVBSD_INV	PKFIL_SEL[1:0]		AUTO_CHK	CHECK_STAT	SLEEP
SRESET		Software Reset 0 = Normal operation. 1 = Reset all serial programming registers to their default values.							
FIELD_ID		Enable SECAM Bottleneck Pulses 0 = Suppress SECAM field synchronization signal. 1 = Enable SECAM synchronization signal (bottleneck pulses).							
CVBSD_INV		Invert CVBS_DLY Outputs 0 = Normal operation. 1 = Invert CVBS_DLY video output on DACs with CVBS_DLY selected.							
PKFIL_SEL[1:0]		Luminance Peaking Filter Selection If FIL_SEL = 0 00 = Filter 0 (Default). 01 = Filter 1 (1 dB gain). 10 = Filter 2 (2 dB gain). 11 = Filter 3 (3.5 dB gain). If FIL_SEL = 1 00 = Filter 4. 01 = Filter 5. 10 = Filter 6. 11 = Filter 7.							
AUTO_CHK		Automatic Monitor Status Checking 0 = Set the connection status bits (MONSTAT_A through MONSTAT_F) by writing to the CHECK_STAT bit. 1 = Check the connection status bits once per frame during the vertical blanking interval.							
CHECK_STAT		Manual Monitor Status Checking Writing a 1 to this bit checks the connection status of the DACs. This is also automatically performed on any reset condition. This bit is automatically cleared.							
SLEEP		Sleep 0 = Normal operation. 1 = Sleep mode. Power down all components except serial interface and PLL. System clock must be applied to wake up part.							

861_040

Register 1C

Register	Default Value	D7	D6	D5	D4	D3	D2	D1	D0
1C	C1	XL_VRI	LC_RST	LOCK	VIDVACTI	VIDHACTI	VIDFIELDI	VIDVALIDI	XL_LOCK
XL_VRI		<p>Accelerated Locking Vertical Realignment Initiation</p> <p>0 = Disable Accelerated Locking Vertical Realignment Initiation.</p> <p>1 = Enable Accelerated Locking Vertical Realignment Initiation.</p> <p>When accelerated VID path locking is enabled, a vertical realignment larger than 18 lines will initiate an accelerated locking adjustment.</p>							
LC_RST		<p>Locking Reset</p> <p>0 = Normal locking operation.</p> <p>1 = Reset locking logic.</p>							
LOCK		<p>Start VID Path Locking</p> <p>0 = Disable VID path locking operation.</p> <p>1 = Normal VID path locking operation.</p>							
VIDVACTI		<p>VIDVACT Polarity Control</p> <p>0 = Active high VIDVACT pin.</p> <p>1 = Active low VIDVACT pin.</p>							
VIDHACTI		<p>VIDHACT Polarity Control</p> <p>0 = Active high VIDHACT pin.</p> <p>1 = Active low VIDHACT pin.</p>							
VIDFIELDI		<p>VIDFIELD Polarity Control</p> <p>0 = A 1 on VIDFIELD pin indicates an even field.</p> <p>1 = A 1 on VIDFIELD pin indicates an odd field.</p>							
VIDVALIDI		<p>VIDVALID Polarity Control</p> <p>0 = Active high VIDVALID pin.</p> <p>1 = Active low VIDVALID pin.</p>							
XL_LOCK		<p>Accelerated Locking</p> <p>0 = Accelerated VID path locking off.</p> <p>1 = Accelerated VID path locking mode.</p>							

Register 1D

Register	Default Value	D7	D6	D5	D4	D3	D2	D1	D0
1D	01	DIS_XTAL	DIS_SCADJ	SYNC_CFG	DIS_PLL	BY_PLL	CLKO_DIS	EACTIVE	CROSSFILT
DIS_XTAL		Disable Crystal Circuitry 0 = Normal operation. 1 = Power down crystal oscillator circuitry.							
DIS_SCADJ		Disable Automatic Subcarrier Adjust 0 = Normal operation. 1 = Disable automatic subcarrier adjustment during locking.							
SYNC_CFG		Sync Configuration 0 = VSYNC* and HSYNC* pins are configured as inputs. 1 = SLAVE and EN_656 registers determine the configuration of VSYNC* and HSYNC* pins. See Table 2-2 .							
DIS_PLL		Sleep PLL 0 = Enable PLL. 1 = Disable PLL. For lower power consumption, disable PLL when not in use.							
BY_PLL		Bypass PLL 1 = Bypass PLL. 0 = Channel XTAL clock through PLL.							
CLKO_DIS		CLKO Disable 0 = Enable CLKO pin. 1 = Disable CLKO pin.							
EACTIVE		Enable Active Video 0 = Black burst video output. 1 = Enable normal video output.							
CROSSFILT		SECAM Cross Color Filter 0 = Apply SECAM luma cross color reduction filter. 1 = Bypass the filter (turn this off when using NTSC/PAL).							

Register 1E

Register	Default Value	D7	D6	D5	D4	D3	D2	D1	D0
1E	E5	SYNC_AMP[7:0]							
SYNC_AMP[7:0]		Sync Tip to Blank Amplitude Measured in LSB increments. 1 LSB = 1.25 V							

Register 1F

Register	Default Value	D7	D6	D5	D4	D3	D2	D1	D0
1F	75	BURST_AMP[7:0]							
BURST_AMP[7:0]		<p>Multiplication Factor for the Colorburst Amplitude for NTSC/PAL This register is ignored when using SECAM.</p> $BURST_AMP = \text{int} \{ BURST_{P-P} \times 2^{10} / [(2 \times 1.28 \text{ Sinc}X + 0.5)] \}$ if PAL = 0 $BURST_AMP = \text{int} [0.707 \times BURST_{P-P} \times 2^{10} / (2 \times 1.28 \text{ Sinc}X + 0.5)]$ if PAL = 1 $BURST_{P-P} = \text{peak to peak burst amplitude in volts}$ $\text{Sinc}X = \text{Sin}[(\pi \times F_{SC} / F_{CLK}) / (\pi \times F_{SC} / F_{CLK})]$							

Register 20

Register	Default Value	D7	D6	D5	D4	D3	D2	D1	D0
20	C1	M_CR[7:0]							
M_CR[7:0]		<p>Multiplication Factor for the Cr Component Prior to Modulation This register is used for colorspace conversion and saturation adjustment.</p> $V = (Cr - 128) \times M_CR / 256$							

Register 21

Register	Default Value	D7	D6	D5	D4	D3	D2	D1	D0
21	89	M_CB[7:0]							
M_CB[7:0]		<p>Multiplication Factor for the Cb Component Prior to Modulation This register is used for colorspace conversion and saturation adjustment.</p> $U = (Cb - 128) \times M_CB / 256$							

Register 22

Register	Default Value	D7	D6	D5	D4	D3	D2	D1	D0
22	9A	M_Y[7:0]							
M_Y[7:0]		<p>Luminance Multiplication Factor (contrast control) M_Y ranges from 0–1.56, such that $M_Y[7:0] = 255 \times \frac{\text{multiplication factor}}{1.56}$ </p>							

Register 23–25

Register	Default Value	D7	D6	D5	D4	D3	D2	D1	D0
23	80	M_COMP_D[7:0]							
24	80	M_COMP_F[7:0]							
25	80	M_COMP_E[7:0]							
M_COMP_D[7:0]		Multiplication Factor for the Component at DAC D							
M_COMP_F[7:0]		Multiplication Factor for the Component at DAC F							
M_COMP_E[7:0]		Multiplication Factor for the Component at DAC E $M_COMP_x = \frac{gain}{128}$, where $0 < gain < 1.99$ DAC output values are truncated to 1023.							

Register 26–29

Register	Default Value	D7	D6	D5	D4	D3	D2	D1	D0
26	1F	M_SC_DR[7:0]							
27	7C	M_SC_DR[15:8]							
28	F0	M_SC_DR[23:16]							
29	21	M_SC_DR[31:24]							
M_SC_DR[31:0]		Subcarrier Increment for NTSC/PAL or Dr for SECAM $M_SC_DR[31:0] = \text{int}((F_{SC} / F_{CLK}) \times 2^{32} + 0.5)$ where: F_{SC} = the subcarrier frequency, F_{CLK} = system clock (luminance sample frequency) Use relationship between HCLK and the subcarrier frequency as given in ITU-R BT.470. See Section 3.1.5 .							

Register 2A–2D

Register	Default Value	D7	D6	D5	D4	D3	D2	D1	D0
2A	13	M_SC_DB[7:0]							
2B	DA	M_SC_DB[15:8]							
2C	4B	M_SC_DB[23:16]							
2D	28	M_SC_DB[31:24]							
M_SC_DB[31:0]		Subcarrier Increment for Db for SECAM $M_SC_DB[31:0] = \text{int}((F_{SC} / F_{CLK}) \times 2^{32} + 0.5)$ where: F_{SC} = subcarrier frequency, F_{CLK} = system clock (luminance sample frequency)							

Register 2E

Register	Default Value	D7	D6	D5	D4	D3	D2	D1	D0
2E	85	SC_AMP[7:0]							
SC_AMP[7:0]		Multiplication Factor for the SECAM Subcarrier Amplitude Measured in LSB increments. $SC_AMP = (Amp_{p-p}) \times (1023 / 1.28 \times SincX)$ <i>where Amp_{p-p} is the peak to peak amplitude of the subcarrier.</i> $SincX = \text{Sin}[(\pi \times F_{SC} / F_{CLK}) / (\pi \times F_{SC} / F_{CLK})]$							

Register 2F–30

Register	Default Value	D7	D6	D5	D4	D3	D2	D1	D0	
2F	A3	DR_MAX[7:0]								
30	05	Reserved					DR_MAX[10:8]			
Reserved bits should be set to zero when written and will return zero when read.										
DR_MAX[10:0]		Upper Boundary for Dr Frequency Deviation in SECAM $DR_MAX = (F_{MAX} / F_{CLK}) \times 2^{13}$								

Register 31–32

Register	Default Value	D7	D6	D5	D4	D3	D2	D1	D0	
31	9F	DR_MIN[7:0]								
32	04	Reserved					DR_MIN[10:8]			
Reserved bits should be set to zero when written and will return zero when read.										
DR_MIN[10:0]		Lower Boundary for Dr Frequency Deviation in SECAM $DR_MIN = (F_{MIN} / F_{CLK}) \times 2^{13}$								

Register 33–34

Register	Default Value	D7	D6	D5	D4	D3	D2	D1	D0	
33	A3	DB_MAX[7:0]								
34	05	Reserved					DB_MAX[10:8]			
Reserved bits should be set to zero when written and will return zero when read.										
DB_MAX[10:0]		Upper Boundary for Db Frequency Deviation in SECAM $DB_MAX = (FMAX / F_{CLK}) \times 2^{13}$								

Register 35–36

Register	Default Value	D7	D6	D5	D4	D3	D2	D1	D0	
35	9F	DB_MIN[7:0]								
36	04	Reserved					DB_MIN[10:8]			
Reserved bits should be set to zero when written and will return zero when read.										
DB_MIN[10:0]		Lower Boundary for Db Frequency Deviation in SECAM $DB_MIN = (FMIN / F_{CLK}) \times 2^{13}$								

Register 37

Register	Default Value	D7	D6	D5	D4	D3	D2	D1	D0
37	00	Y_OFF[7:0]							
Y_OFF[7:0]		Luminance Level Offset (brightness control) The luminance level offset is referenced from black, and can be adjusted from –22.31 IRE (below black) to +22.14 IRE (above black). Active video will be added to the offset level. Y_OFF is a two's complement number, such that 0x00 = 0 IRE offset, 0x0F is +22.14 IRE offset, and 0x10 is –22.31 IRE offset.							

Register 38

Register	Default Value	D7	D6	D5	D4	D3	D2	D1	D0
38	00	PHASE_OFF[7:0]							
PHASE_OFF[7:0]		Subcarrier Phase Offset (for SC – H Phase Adjustments) $PHASE_OFF = 256 \times \frac{phase\ offset}{360^\circ}$ Phase offset ranges from 0° – 358.6°.							

Register 39–3A

Register	Default Value	D7	D6	D5	D4	D3	D2	D1	D0
39	50	ALPHA_LUT_1[3:0]				ALPHA_LUT_0[3:0]			
3A	FA	ALPHA_LUT_3[3:0]				ALPHA_LUT_2[3:0]			
ALPHA_LUT_0[3:0]	Alpha Blend Lookup Table Element 0								
ALPHA_LUT_1[3:0]	Alpha Blend Lookup Table Element 1								
ALPHA_LUT_2[3:0]	Alpha Blend Lookup Table Element 2								
ALPHA_LUT_3[3:0]	Alpha Blend Lookup Table Element 3								
Alpha blend multiplier look-up table when using content-based blending. (BLEND MODE = 0) and when using pin-based blending in either 1-bit or 2-bit modes (BLEND MODE = 1 and ALPHAMODE = 01 or 10). If 1-bit pin-based alpha is used, a 0 on ALPHA[0] applies. ALPHA_LUT_0 and a 1 applies ALPHA_LUT_3.									

Register 3B

Register	Default Value	D7	D6	D5	D4	D3	D2	D1	D0
3B	00	HUE_ADJUST[7:0]							
HUE_ADJUST[7:0]	Hue Adjustment by Subcarrier Shift $HUE_ADJUST = 256 \times \frac{(Phase)}{360^\circ}$ The hue adjustment ranges from 0° to 358.6°								

Register 3C

Register	Default Value	D7	D6	D5	D4	D3	D2	D1	D0
3C	10	VIDCLK_EDGE	YDELAY[0]	XL_MDSEL[1:0]		XL_SATEN	FIL_SEL	SCART_SEL	
VIDCLK_EDGE		VIDCLK EDGE Sample Select 0 = VID[7:0], VIDHACT, VIDVALT, VIDFIELD, VIDVALID are sampled on the rising edge of the VIDCLK. 1 = VID[7:0], VIDHACT, VIDVALT, VIDFIELD, VIDVALID are sampled on the falling edge of the VIDCLK.							
YDELAY[0]		Luma Delay is System Clock Counts for CVBS_DLY Outputs. The MSBs for YDELAY are located in register 18. 0 = No delay. 1 = One system clock delay (1/2 pixel).							
XL_MDSEL[1:0]		Accelerated Locking Mode Select 00 = Rapid frequency adjustment. 01 = Moderate frequency adjustment. 11 = Slow frequency adjustment.							
XL_SATEN		Accelerated Locking Saturation Enable 00 = Disable accelerated locking saturation limit. 01 = Enable a saturation limit for the initial internal PLL adjustment of the accelerated locking sequence. The limit value is determined by the XL_SAT register field (73[3:0]).							
FIL_SEL		Filters Select 0 = Enable peaking filters. 1 = Enable reduction filters. See PKFIL_SEL register bit description.							
SCART_SEL		Scart Selection Options 00 = Disable SCART functionality on ALTADDR pin. 01 = ALTDDR pin is VBLANK signal. 10 = ALTDDR pin is composite sync signal. 11 = ALTDDR pin is composite blank signal. These signals are synchronized with the DAC outputs. See Figure 3-15 .							

Register 40–41

Register	Default Value	D7	D6	D5	D4	D3	D2	D1	D0
40	80	XDSB1[7:0]							
41	80	XDSB2[7:0]							
XDSB1[7:0]		First Byte of Extended Data Services Information Data is encoded LSB first.							
XDSB2[7:0]		Second Byte of Extended Data Services Information Data is encoded LSB first.							

Register 42–43

Register	Default Value	D7	D6	D5	D4	D3	D2	D1	D0
42	80	CCB1[7:0]							
43	80	CCB2[7:0]							
CCB1[7:0]		First Byte of Closed Captioning Information Data is encoded LSB first.							
CCB2[7:0]		Second Byte of Closed Captioning Information Data is encoded LSB first.							

Register 44–45

Register	Default Value	D7	D6	D5	D4	D3	D2	D1	D0
44	4A	CCSTART[7:0]							
45	01	Reserved							CCSTART[8]
Reserved bits should be set to zero when written and will return zero when read.									
CCSTART[8:0]		Closed Captioning or Extended Data Services Start Placement Number of clocks from leading edge of HSYNC* to start of Closed Captioning or Extended Data Services clock run-in. Default value is correct for 27 MHz operation.							

Register 46–47

Register	Default Value	D7	D6	D5	D4	D3	D2	D1	D0	
46	8C	CCADD[7:0]								
47	09	Reserved				CCADD[11:8]				
Reserved bits should be set to zero when written and will return zero when read.										
CCADD[11:0]		Closed Captioning or Extended Data Services DTO Increment Defines the width of Closed Captioning or Extended Data Services waveform. Default value is correct for 27 MHz operation.								

Register 48

Register	Default Value	D7	D6	D5	D4	D3	D2	D1	D0	
48	00	Reserved					ECCGATE	EXDS	ECC	
<p>Reserved bits should be set to zero when written and will return zero when read.</p> <p>ECCGATE Closed Captioning Gating 0 = After current CC/XDS data is encoded, send Null data sequence until new data is written to registers. 1 = Repeat current CC/XDS data until new data is written to the registers.</p> <p>EXDS Enable Extended Data Services 0 = Disable Extended Data Services encoding. 1 = Enable Extended Data Services encoding.</p> <p>ECC Enable Closed Captioning 0 = Disable Closed Captioning encoding. 1 = Enable Closed Captioning encoding.</p>										

Register 49

Register	Default Value	D7	D6	D5	D4	D3	D2	D1	D0																														
49	44	XDSSEL[3:0]				CCSEL[3:0]																																	
<p>XDSSEL[3:0] Line Position of Extended Data Services Content Controls which line Extended Data Services data is encoded. Each line enable is independent. 0 = Enable line. 1 = Disable line.</p> <table border="1"> <thead> <tr> <th>Bit</th> <th>Closed Captioning Line (525-line)</th> <th>Closed Captioning Line (625-line)</th> </tr> </thead> <tbody> <tr> <td>XDSSEL[0]</td> <td>282</td> <td>333</td> </tr> <tr> <td>XDSSEL[1]</td> <td>283</td> <td>334</td> </tr> <tr> <td>XDSSEL[2]</td> <td>284</td> <td>335</td> </tr> <tr> <td>XDSSEL[3]</td> <td>285</td> <td>336</td> </tr> </tbody> </table> <p>CCSEL[3:0]3 Line Position of Closed Captioning Content Controls which line Closed Captioning data is encoded. Each line enable is independent. 0 = Enable line. 1 = Disable line.</p> <table border="1"> <thead> <tr> <th>Bit</th> <th>Closed Captioning Line (525-line)</th> <th>Closed Captioning Line (625-line)</th> </tr> </thead> <tbody> <tr> <td>CCSEL[0]</td> <td>19</td> <td>21</td> </tr> <tr> <td>CCSEL[1]</td> <td>20</td> <td>22</td> </tr> <tr> <td>CCSEL[2]</td> <td>21</td> <td>23</td> </tr> <tr> <td>CCSEL[3]</td> <td>22</td> <td>24</td> </tr> </tbody> </table>										Bit	Closed Captioning Line (525-line)	Closed Captioning Line (625-line)	XDSSEL[0]	282	333	XDSSEL[1]	283	334	XDSSEL[2]	284	335	XDSSEL[3]	285	336	Bit	Closed Captioning Line (525-line)	Closed Captioning Line (625-line)	CCSEL[0]	19	21	CCSEL[1]	20	22	CCSEL[2]	21	23	CCSEL[3]	22	24
Bit	Closed Captioning Line (525-line)	Closed Captioning Line (625-line)																																					
XDSSEL[0]	282	333																																					
XDSSEL[1]	283	334																																					
XDSSEL[2]	284	335																																					
XDSSEL[3]	285	336																																					
Bit	Closed Captioning Line (525-line)	Closed Captioning Line (625-line)																																					
CCSEL[0]	19	21																																					
CCSEL[1]	20	22																																					
CCSEL[2]	21	23																																					
CCSEL[3]	22	24																																					

Register 4A–4C

Register	Default Value	D7	D6	D5	D4	D3	D2	D1	D0
4A	—	EWSSF2	EWSSF1	Reserved	SQUARE	WSDAT[4:1]			
4B	—	WSDAT[12:5]							
4C	—	WSDAT[20:13]							
Reserved bits should be set to zero when written and will return zero when read.									
EWSSF2		Enable CGMS Function on Field 2 0 = Disable field 2 data. 1 = Enable field 2 data (525 line mode only).							
EWSSF1		Enable WSS or CGMS Function on Field 1 0 = Disable field 1 data. 1 = Enable field 1 data.							
SQUARE		Square Pixel or CCIR Timing Select for Teletext and WSS 0 = ITU-R BT.601 operation for Teletext and WSS. 1 = Square pixel operation for Teletext and WSS.							
WSDAT[20:1]		WSS and CGMS Data Bits							

Register 4D–4E

Register	Default Value	D7	D6	D5	D4	D3	D2	D1	D0	
4D	39	TTXHS[7:0]								
4E	01	Reserved					TTXHS[10:8]			
Reserved bits should be set to zero when written and will return zero when read.										
TTXHS[10:0]		TTXREQ Rising Edge Number of clocks from falling edge of HSYNC* to rising edge of TTXREQ minus an offset. Used when TXRM = 0. <i>TTXHS = (desired distance in clocks) – 2 (3 for slave mode)</i>								

Register 4F–50

Register	Default Value	D7	D6	D5	D4	D3	D2	D1	D0	
4F	07	TTXHE[7:0]								
50	00	Reserved					TTXHE[10:8]			
Reserved bits should be set to zero when written and will return zero when read.										
TTXHE[10:0]		TTXREQ Falling Edge Number of clocks from falling edge of HSYNC* to falling edge of TTXREQ minus an offset. Used when TXRM = 0. $TTXHE = (\text{desired distance in clocks}) - 2$ (3 for slave mode)								

Register 51–52

Register	Default Value	D7	D6	D5	D4	D3	D2	D1	D0
51	00	TTXBF1[7:0]							
52	00	Reserved							TTXBF1[8]
Reserved bits should be set to zero when written and will return zero when read.									
TTXBF1[8:0]		Teletext Start Line for Field 1 Line number of first line of Teletext data for field 1 ⁽¹⁾ .							

Register 53–54

Register	Default Value	D7	D6	D5	D4	D3	D2	D1	D0
53	00	TTXEF1[7:0]							
54	00	Reserved							TTXEF1[8]
Reserved bits should be set to zero when written and will return zero when read.									
TTXEF1[8:0]		Teletext End Line for Field 1 Line number of last line of Teletex data for field 1 ⁽¹⁾ .							

Register 55–56

Register	Default Value	D7	D6	D5	D4	D3	D2	D1	D0	
55	00	TTXBF2[7:0]								
56	00	Reserved							TTXBF2[8]	
Reserved bits should be set to zero when written and will return zero when read.										
TTXBF2[8:0]		Teletext Start Line for Field 2 Line number of first line of Teletext data for field 2, counted from top of field 2 ⁽¹⁾ . (TTXBF2 + 313 = PAL/SECAM line)								

Register 57–58

Register	Default Value	D7	D6	D5	D4	D3	D2	D1	D0	
57	00	TTXEF2[7:0]								
58	00	Reserved							TTXEF2[8]	
Reserved bits should be set to zero when written and will return zero when read.										
TTXEF2[8:0]		Teletext End Line for Field 2 Line number of last line of Teletext data for field 2, counted from top of field 2 ⁽¹⁾ . (TTXEF2 + 313 = PAL/SECAM line)								

Register 59

Register	Default Value	D7	D6	D5	D4	D3	D2	D1	D0	
59	02	Reserved						TXRM	TXE	
Reserved bits should be set to zero when written and will return zero when read.										
TXRM		TTXREQ Configuration 0 = TTXREQ pin generates request signal based on TTXHS and TTXHE. 1 = TTXREQ pin generates a clock to latch data on TTXDAT pin.								
TXE		Teletext Enable 0 = Disable Teletext encoding. 1 = Enable Teletext encoding.								

Register 5A–5B

Register	Default Value	D7	D6	D5	D4	D3	D2	D1	D0																																				
5A	00	TTX_DIS[7:0]																																											
5B	00	TTX_DIS[15:8]																																											
Reserved bits should be set to zero when written and will return zero when read.																																													
TTX_DIS[15:0] Teletext Disable by Line A 1 in these bits disables individual lines of Teletext encoding.																																													
<table border="1"> <thead> <tr> <th>Bit</th> <th>TTX Line (F1 / F2)</th> <th>Bit</th> <th>TTX Line (F1 / F2)</th> </tr> </thead> <tbody> <tr> <td>TTX_DIS[0]</td> <td>8 / 321</td> <td>TTX_DIS[8]</td> <td>16 / 329</td> </tr> <tr> <td>TTX_DIS[1]</td> <td>9 / 322</td> <td>TTX_DIS[9]</td> <td>17 / 330</td> </tr> <tr> <td>TTX_DIS[2]</td> <td>10 / 323</td> <td>TTX_DIS[10]</td> <td>18 / 331</td> </tr> <tr> <td>TTX_DIS[3]</td> <td>11 / 324</td> <td>TTX_DIS[11]</td> <td>19 / 332</td> </tr> <tr> <td>TTX_DIS[4]</td> <td>12 / 325</td> <td>TTX_DIS[12]</td> <td>20 / 333</td> </tr> <tr> <td>TTX_DIS[5]</td> <td>13 / 326</td> <td>TTX_DIS[13]</td> <td>21 / 334</td> </tr> <tr> <td>TTX_DIS[6]</td> <td>14 / 327</td> <td>TTX_DIS[14]</td> <td>22 / 335</td> </tr> <tr> <td>TTX_DIS[7]</td> <td>15 / 328</td> <td>TTX_DIS[15]</td> <td>23 / 336</td> </tr> </tbody> </table>										Bit	TTX Line (F1 / F2)	Bit	TTX Line (F1 / F2)	TTX_DIS[0]	8 / 321	TTX_DIS[8]	16 / 329	TTX_DIS[1]	9 / 322	TTX_DIS[9]	17 / 330	TTX_DIS[2]	10 / 323	TTX_DIS[10]	18 / 331	TTX_DIS[3]	11 / 324	TTX_DIS[11]	19 / 332	TTX_DIS[4]	12 / 325	TTX_DIS[12]	20 / 333	TTX_DIS[5]	13 / 326	TTX_DIS[13]	21 / 334	TTX_DIS[6]	14 / 327	TTX_DIS[14]	22 / 335	TTX_DIS[7]	15 / 328	TTX_DIS[15]	23 / 336
Bit	TTX Line (F1 / F2)	Bit	TTX Line (F1 / F2)																																										
TTX_DIS[0]	8 / 321	TTX_DIS[8]	16 / 329																																										
TTX_DIS[1]	9 / 322	TTX_DIS[9]	17 / 330																																										
TTX_DIS[2]	10 / 323	TTX_DIS[10]	18 / 331																																										
TTX_DIS[3]	11 / 324	TTX_DIS[11]	19 / 332																																										
TTX_DIS[4]	12 / 325	TTX_DIS[12]	20 / 333																																										
TTX_DIS[5]	13 / 326	TTX_DIS[13]	21 / 334																																										
TTX_DIS[6]	14 / 327	TTX_DIS[14]	22 / 335																																										
TTX_DIS[7]	15 / 328	TTX_DIS[15]	23 / 336																																										

Register 5C–5F

Register	Default Value	D7	D6	D5	D4	D3	D2	D1	D0
5C	7F	MULT_UU[7:0]							
5D	00	MULT_VU[7:0]							
5E	00	MULT_UV[7:0]							
5F	7F	MULT_VV[7:0]							
<p>MULT_UU[7:0] Chrominance Matrix Multiplier</p> <p>MULT_VU[7:0] Chrominance Matrix Multiplier</p> <p>MULT_UV[7:0] Chrominance Matrix Multiplier</p> <p>MULT_VV[7:0] Chrominance Matrix Multiplier</p> <p>To rotate the hue by an angle θ, program the matrix multipliers as follows (except that the value of +128 should be made +127). All register are twos complement.</p> <p>MULT_UU = $128 \times \text{Cos}(\theta)$ MULT_VU = $128 \times \text{Sin}(\theta)$ MULT_UV = $128 \times \text{Sin}(\theta)$ MULT_VV = $128 \times \text{Cos}(\theta)$</p>									

Register 70–71

Register	Default Value	D7	D6	D5	D4	D3	D2	D1	D0
70	80	LC_FIFOWIN[7:0]							
71	01	Reserved							LC_FIFOWIN[8]
Reserved bits should be set to zero when written and will return zero when read.									
LC_FIFOWIN[8:0]		FIFO Window Defines the number of FIFO locations used to accommodate VID port input.							

Register 72

Register	Default Value	D7	D6	D5	D4	D3	D2	D1	D0
72	80	LC_MAXOFF[7:0]							
LC_MAXOFF[7:0]		Max Adjustment Defines the maximum internal PLL adjustment applied when locking is enabled.							

Register 73

Register	Default Value	D7	D6	D5	D4	D3	D2	D1	D0
73	72	XL_GAIN[3:0]				XL_SAT[3:0]			
XL_GAIN[3:0]		Accelerated Locking Gain Defines the gain applied to the detected frequency error to calculate the internal PLL adjustment for accelerated locking.							
XL_SAT[3:0]		Accelerated Locking Saturation Defines the saturation limit applied to the initial internal PLL adjustment of the accelerated locking sequence when XL_SATEN is set.							

6.0 Parametric Data and Specifications

6.1 Electrical Specifications

6.1.1 Electrical Parameters

Table 6-1. Absolute Maximum Ratings

Parameter	Symbol	Min ⁽²⁾	Typ	Max ⁽²⁾	Units
VAA, VDD (measured to GND)	—	—	—	7.0	V
Voltage on Any Signal Pin ⁽¹⁾	—	GND – 0.5	—	VDD + 0.5	V
Analog Output Short Circuit Duration to Any Power Supply or Common	I _{SC}	—	Indefinite	—	—
Storage Temperature	T _S	–65	—	+150	°C
Junction Temperature	T _J	—	—	+125	°C
Vapor Phase Soldering (1 Minute)	T _{VSOL}	—	—	220	°C
NOTE(S): (1) This device employs high-impedance CMOS devices on all signal pins. It should be handled as an ESD-sensitive device. Voltage on any signal pin that exceeds the power supply or ground voltage by more than 0.5 V can cause destructive latchup. (2) Stresses beyond limits listed in this table may cause permanent damage to the device. This is a stress rating only, and functional operation of the device at these or any other conditions above those listed in the operational sections of this specification is not implied. Exposure to absolute maximum rating conditions for extended periods may affect device reliability.					

Table 6-2. DC Characteristics

Parameter	Min	Typ	Max	Units
Output Current-DAC Code 1023 (I_{OUT} Full Scale)	—	34.13	—	mA
Output Voltage-DAC Code 1023	—	1.28	—	V
Video Level Error (Nominal Resistors)	—	—	5	%
DAC Output Capacitance	—	22	—	pF
Digital Inputs (Except SID, SIC)				
Input High Voltage	2.0	—	VDD + 0.5	V
Input Low Voltage	GND – 0.5	—	0.8	V
Input High Current ($V_{in} = 2.4$ V)	—	—	1	μ A
Input Low Current ($V_{in} = 0.4$ V)	—	—	–1	μ A
Input Capacitance ($f = 1$ MHz, $V_{in} = 2.4$ V)	—	7	—	pF
SID, SIC				
Input High Voltage	2.4	—	5.25	V
Input Low Voltage	–0.5	—	0.8	V
Digital Outputs				
Output High Voltage ($I_{OH} = -400$ μ A)	2.4	—	VDD	V
Output Low Voltage ($I_{OL} = 3.2$ mA)	GND	—	0.4	V
Three-State Current	—	—	50	μ A
Output Capacitance	—	10	—	pF
Recommended Operating Conditions				
Power Supply (VAA,VDD)	3.00	3.30	3.60	V
Ambient Operating Temperature (T_A)	0	—	70	$^{\circ}$ C
DAC Output Load (R_L)	—	37.5	—	Ω
Nominal RSET (RSET)	—	300	—	Ω
Thermal Resistance of Package (θ_{JA})	—	43	—	$^{\circ}$ C/W
NOTE(S): As the above parameters are guaranteed over the full temperature range (0 $^{\circ}$ C to 70 $^{\circ}$ C), temperature coefficients are not specified or required. Typical values are based on nominal temperature, i.e., room temperature, and nominal voltage, i.e., 3.3 V.				

Figure 6-1. Pixel and Control Data Timing Diagram

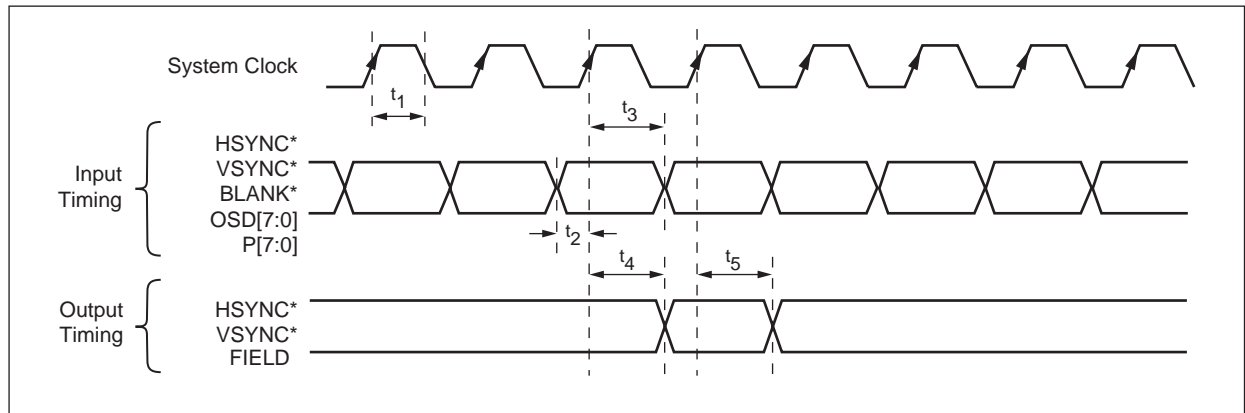

861_038

Table 6-3. AC Characteristics

Parameter	Conditions	Minimum	Typical	Maximum	Units
CLKIN Frequency ⁽¹⁾		—	27	—	MHz
CLKIN Pulse Width Duty Cycle	t_1	40	50	60	%
Pixel/Control Setup Time	t_2	3	—	12	ns
Pixel/Control Hold Time	t_3	0	—	—	ns
Control Output Delay Time	t_4	—	—	15	ns
Control Output Hold Time	t_5	2	—	—	ns
Power Characteristics					
Total current	6 DACs enabled	—	350	—	mA
VAA Supply Current	6 DACs enabled	—	250	—	mA
VDD Supply Current	—	—	100	—	mA
Sleep Current	Using CLKIN as source, PLL and crystal circuitry disabled	—	4	—	mA
DAC Current	RSET = 300 Ω , R _{load} = 37.5 Ω	—	34.13	—	mA
PLL Current	—	—	12	—	mA
Crystal Circuitry Current	—	—	2	—	mA
NOTE(S):					
⁽¹⁾ The target frequency is 27 MHz for ITU-R BT.601 timing, 24.5454 MHz for 525 line square pixel timing and 29.5 MHz for 625 line square pixel timing.					

Table 6-4. Video Quality Specifications

Parameter	Conditions	Min	Typical	Max	Units
Differential Phase	NTC-7 Composite	—	2.3	—	deg p-p
Differential Gain	NTC-7 Composite	—	0.67	—	% p-p
Chrominance Nonlinear Gain	NTC-7 Combination, Referenced to 40 IRE	—	1.75	—	+/- %
Chrominance Nonlinear Phase	NTC-7 Combination, Referenced to 40 IRE	—	0.1	—	+/- deg
Chroma/Luma Intermodulations	NTC-7 Combination, Referenced to 40 IRE	—	0.2	—	+/- %
Luminance Nonlinearity	10 step Luminance Staircase	—	1.1	—	+/- %
Chroma/Luma gain inequality	NTC-7 Composite	—	0.3	—	+/- %
Chroma/Luma Delay inequality	NTC-7 Composite	—	0.9	—	ns
SNR	Luminance Ramp, tilt null engaged	—	-61.5	—	dB RMS
SNR	50 IRE Pedestal	—	-73	—	dB RMS
SNR	50 IRE Pedestal	—	-78.5	—	dB p-p
Chroma AM	Red Field	—	-65	—	dB
Chroma PM	Red Field	—	-65	—	dB
Frequency Response ⁽¹⁾⁽²⁾	0.5 MHz Packet, Multiburst	—	-0.67	—	dB
—	1 MHz Packet, Multiburst	—	-0.71	—	dB
—	2 MHz Packet, Multiburst	—	-0.83	—	dB
—	3 MHz Packet, Multiburst	—	-0.94	—	dB
—	3.58 MHz Packet, Multiburst	—	-1.07	—	dB
—	4.2 MHz Packet, Multiburst	—	-1.23	—	dB
Color Saturation Accuracy	—	—	1	—	IRE
Hue Accuracy	—	—	1	—	deg
DAC to DAC matching	—	—	—	5	%
<p>NOTE(S):</p> <p>(1) Internal peaking and reduction filters not engaged.</p> <p>(2) Without external reconstruction filter.</p> <p>3. Temperature range tested: 0 °C to 70 °C.</p> <p>4. Power supply voltage tested: 2.7 V to 3.6 V.</p>					

6.2 Mechanical Drawing

Figure 6-2. 80 MQFP Package Diagram

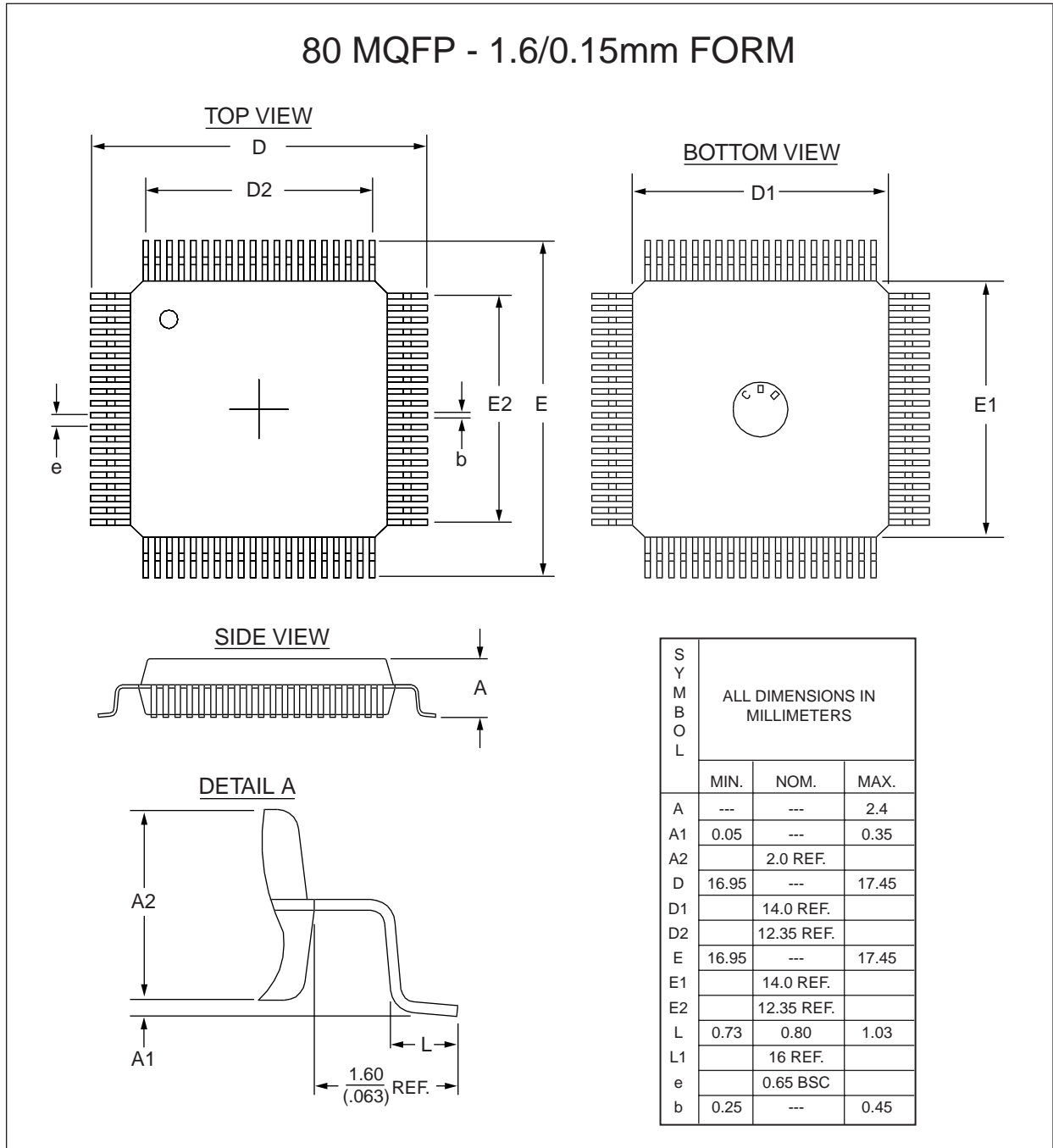

861_041

**Further Information**

literature@conexant.com
1-800-854-8099 (North America)
33-14-906-3980 (International)

Web Site

www.conexant.com

World Headquarters

Conexant Systems, Inc.
4311 Jamboree Road
P. O. Box C
Newport Beach, CA
92658-8902
Phone: (949) 483-4600
Fax: (949) 483-6375

U.S. Florida/South America

Phone: (727) 799-8406
Fax: (727) 799-8306

U.S. Los Angeles

Phone: (805) 376-0559
Fax: (805) 376-8180

U.S. Mid-Atlantic

Phone: (215) 244-6784
Fax: (215) 244-9292

U.S. North Central

Phone: (630) 773-3454
Fax: (630) 773-3907

U.S. Northeast

Phone: (978) 692-7660
Fax: (978) 692-8185

U.S. Northwest/Pacific West

Phone: (408) 249-9696
Fax: (408) 249-7113

U.S. South Central

Phone: (972) 733-0723
Fax: (972) 407-0639

U.S. Southeast

Phone: (919) 858-9110
Fax: (919) 858-8669

U.S. Southwest

Phone: (949) 483-9119
Fax: (949) 483-9090

APAC Headquarters

Conexant Systems Singapore, Pte.
Ltd.
1 Kim Seng Promenade
Great World City
#09-01 East Tower
SINGAPORE 237994
Phone: (65) 737 7355
Fax: (65) 737 9077

Australia

Phone: (61 2) 9869 4088
Fax: (61 2) 9869 4077

China

Phone: (86 2) 6361 2515
Fax: (86 2) 6361 2516

Hong Kong

Phone: (852) 2827 0181
Fax: (852) 2827 6488

India

Phone: (91 11) 692 4780
Fax: (91 11) 692 4712

Korea

Phone: (82 2) 565 2880
Fax: (82 2) 565 1440

Phone: (82 53) 745 2880

Fax: (82 53) 745 1440

Europe Headquarters

Conexant Systems France
Les Taissounieres B1
1681 Route des Dolines
BP 283
06905 Sophia Antipolis Cedex
FRANCE
Phone: (33 4) 93 00 33 35
Fax: (33 4) 93 00 33 03

Europe Central

Phone: (49 89) 829 1320
Fax: (49 89) 834 2734

Europe Mediterranean

Phone: (39 02) 9317 9911
Fax: (39 02) 9317 9913

Europe North

Phone: (44 1344) 486 444
Fax: (44 1344) 486 555

Europe South

Phone: (33 1) 41 44 36 50
Fax: (33 1) 41 44 36 90

Middle East Headquarters

Conexant Systems
Commercial (Israel) Ltd.
P. O. Box 12660
Herzlia 46733, ISRAEL
Phone: (972 9) 952 4064
Fax: (972 9) 951 3924

Japan Headquarters

Conexant Systems Japan Co., Ltd.
Shimomoto Building
1-46-3 Hatsudai,
Shibuya-ku, Tokyo
151-0061 JAPAN
Phone: (81 3) 5371-1567
Fax: (81 3) 5371-1501

Taiwan Headquarters

Conexant Systems, Taiwan Co., Ltd.
Room 2808
International Trade Building
333 Keelung Road, Section 1
Taipei 110, TAIWAN, ROC
Phone: (886 2) 2720 0282
Fax: (886 2) 2757 6760