

15HSC Series

RADIATION HARD HIGH SPEED CMOS/SOS LOGIC

The 15HSC Series offer the combined benefits of low power, high speed CMOS with the inherent latch up immunity, Single Event Upset (SEU) immunity and high level of radiation hardness of Silicon on Sapphire technology.

The 15HSC Series of CMOS/SOS devices are pin compatible with the 54LS Series and the 54HSC Series, but with a higher speed capability.

Further device types to those listed will be available shortly. Please contact GPS for further information.

DEVICE TYPES

15HSC138	3-Line to 8-Line Decoder/Multiplexer
15HSC163	Synchronous 4-Bit Counter

FEATURES

- Radiation Hard to 1.5 μ m CMOS/SOS Technology
- High SEU Immunity
- Latch Up Free
- Low Power CMOS/SOS Technology
- Plug In Replacement for 54/74LS, HC and HCT
- Dual In Line or Flatpack Packages
- High Speed (Toggle Rate 100MHz)

15HSC Series

DC CHARACTERISTICS AND RATINGS

Parameter	Min	Max	Units
Supply Voltage	-0.5	10	V
Input Voltage	-0.3	$V_{DD}+0.3$	V
Current Through Any Pin	-25	+25	mA
Operating Temperature	-55	125	°C
Storage Temperature	-65	150	°C

Note: Stresses above those listed may cause permanent damage to the device. This is a stress rating only and functional operation of the device at these conditions, or at any other condition above those indicated in the operations section of this specification, is not implied. Exposure to absolute maximum rating conditions for extended periods may affect device reliability.

Figure 1: Absolute Maximum Ratings

Symbol	Parameter	Conditions	Total dose radiation not exceeding 3×10^5 Rad(Si)			Total dose ≤ 1 M Rad(Si)		Units
			Min	Typ	Max	Min	Max	
V_{DD}	Supply Voltage	-	4.5	5.0	5.5	4.5	5.5	V
V_{IH1}	HST Input High Voltage	-	2.0	-	-	2.0	-	V
V_{IL1}	HST Input Low Voltage	-	-	-	0.8	-	0.3	V
V_{IH2}	HSC Input High Voltage	-	3.5	-	-	3.5	-	V
V_{IL2}	HSC Input Low Voltage	-	-	-	1.5	-	1.0	V
V_{OH}	Output High Voltage	$V_{IN} = V_{IH}$ or V_{IL} $I_{OH} = -20\mu A^*$	$V_{DD}-0.1$	-	-	$V_{DD}-0.1$	-	V
		$I_{OH} = -6.0mA^*$	3.7	-	-	3.7	-	V
		$I_{OH} = -11.0mA$	2.5	-	-	2.5	-	V
V_{OL}	Output Low Voltage	$V_{IN} = V_{IH}$ or V_{IL} $I_{OL} = 20\mu A^*$	-	-	0.1	-	0.1	V
		$I_{OL} = 6.0mA^*$	-	-	0.2	-	0.2	V
		$I_{OL} = 9.0mA$	-	-	0.4	-	0.4	V
I_{IL}	Input Leakage Current	$V_{IN} = V_{DD}$ or V_{SS} All inputs	-	-	± 10	-	± 10	μA
I_{OL}	Output Leakage Current	$V_{OUT} = V_{DD}$ or V_{SS} Outputs disabled	-	-	TBD	-	TBD	μA
I_{DD}	Quiescent Current	$V_{IN} = V_{DD}$ Outputs unloaded	-	-	TBD	-	TBD	mA

$V_{DD} = 5V \pm 10\%$, over full operating temperature range.

* = Guaranteed but not tested.

Figure 2: Electrical Characteristics

15HSC138 : 3-Line to 8-Line Decoder/Multiplexer

Enable Inputs			Select Inputs			Outputs							
G ₁	GN _{2A}	GN _{2B}	C	B	A	Y ₀	Y ₁	Y ₂	Y ₃	Y ₄	Y ₅	Y ₆	Y ₇
X	H	X	X	X	X	H	H	H	H	H	H	H	H
X	X	H	X	X	X	H	H	H	H	H	H	H	H
L	X	X	X	X	X	H	H	H	H	H	H	H	H
H	L	L	L	L	L	L	H	H	H	H	H	H	H
H	L	L	L	L	H	H	L	H	H	H	H	H	H
H	L	L	L	H	L	H	H	L	H	H	H	H	H
H	L	L	L	H	H	H	H	L	H	H	H	H	H
H	L	L	H	L	L	H	H	H	H	L	H	H	H
H	L	L	H	L	H	H	H	H	H	H	L	H	H
H	L	L	H	H	L	H	H	H	H	H	H	L	H
H	L	L	H	H	H	H	H	H	H	H	H	H	L

H = high level, L = low level, X = irrelevant

Figure 3: Function Table

Symbol	Parameter	Spice Simulation	Max.	Units
t _{PLH}	Propagation delay. Address to Output	7.6	15	ns
t _{PHL}	Propagation delay. Address to Output.	7.4	15	ns
t _{PLH}	Propagation delay. G to Output	9.3	15	ns
t _{PHL}	Propagation delay. G to Output	8.8	15	ns

Figure 4: Switching Characteristics

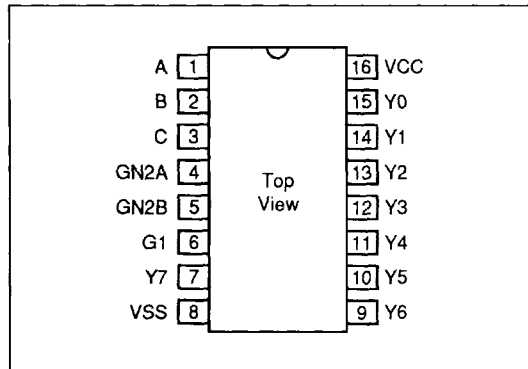

Figure 5: DIL Pin Out

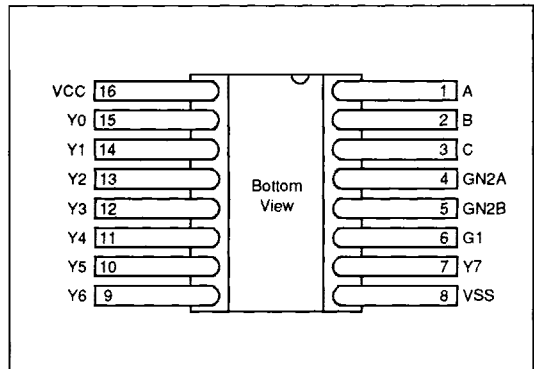

Figure 6: Flatpack Pin Out

15HSC Series

15HSC163 : 4-Bit Counter with Synchronous Clear

Symbol	Parameter	Spice Simulation	Max.	Units
t_{PLH}	Propagation delay. Clock to RCO	11.5	15	ns
t_{PHL}	Propagation delay. Clock to RCO	11.4	15	ns
t_{PLH}	Propagation delay. Clock to any Q	9.4	15	ns
t_{PHL}	Propagation delay. Clock to any Q	9.6	15	ns
t_{PLH}	Propagation delay. ENT to RCO	8.5	15	ns
t_{PHL}	Propagation delay. ENT to RCO	8.4	15	ns

Figure 7: Switching Characteristics

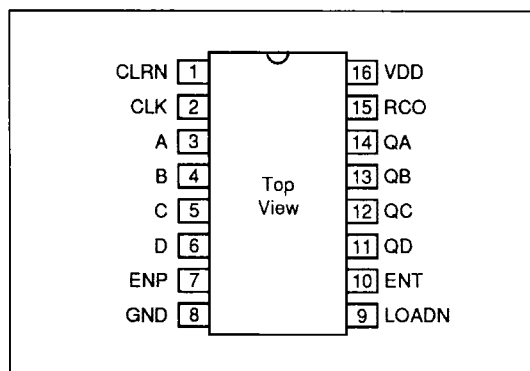

Figure 8: DIL Pin Out

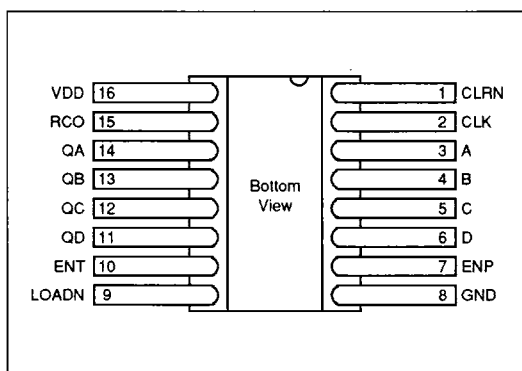

Figure 9: Flatpack Pin Out

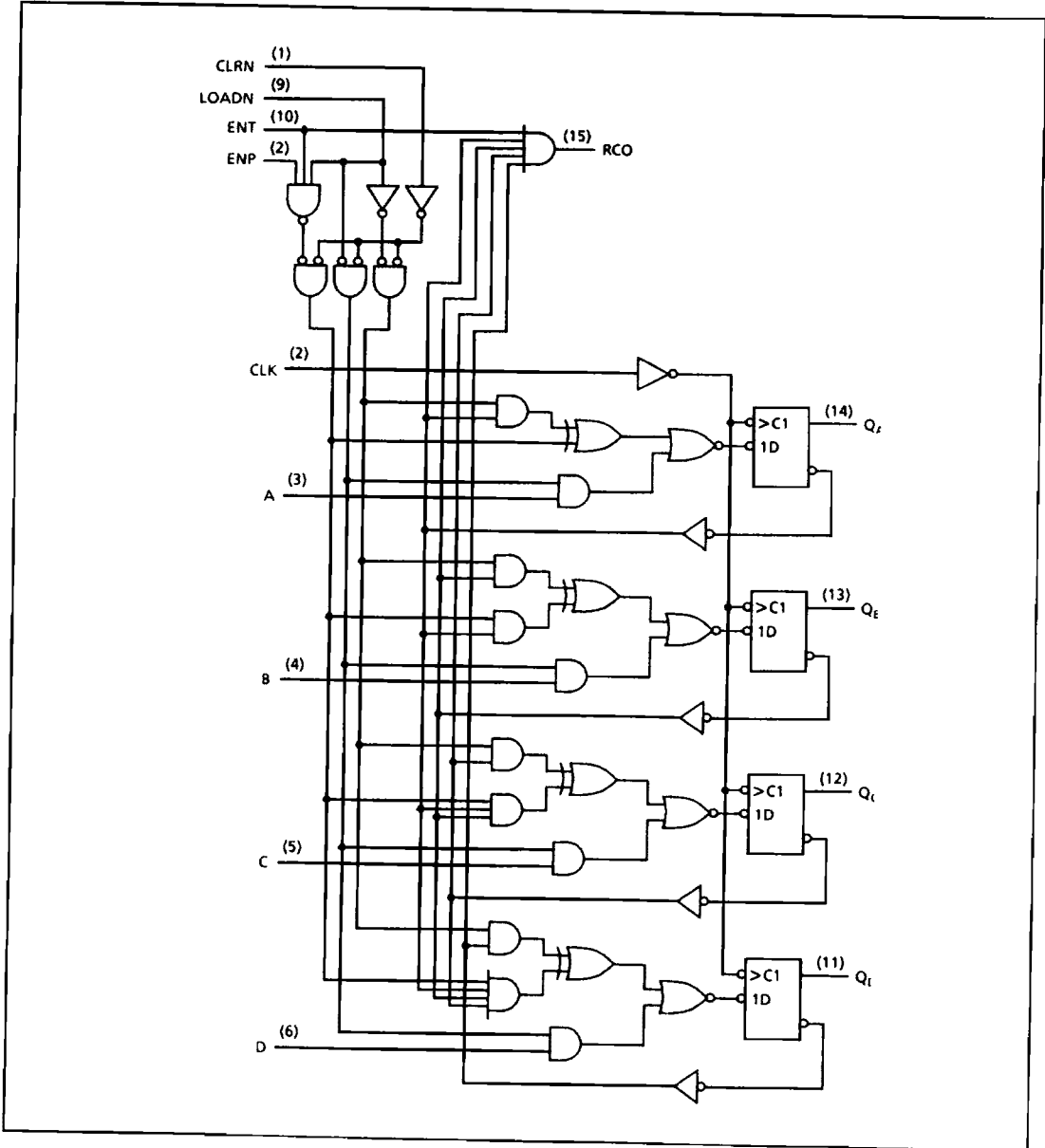

Figure 10: Logic Diagram

15HSC Series

Ref	Millimetres			Inches		
	Min.	Nom.	Max.	Min.	Nom.	Max.
A	-	-	5.60	-	-	0.220
A1	0.38	-	1.53	0.015	-	0.060
b	0.35	-	0.59	0.014	-	0.023
c	0.20	-	0.36	0.008	-	0.014
D	-	-	20.58	-	-	0.810
e	-	2.54 Typ.	-	-	0.100 Typ.	-
e1	-	7.62 Typ.	-	-	0.300 Typ.	-
H	4.45	-	5.38	0.175	-	0.212
Me	-	-	8.30	-	-	0.326
Z	-	-	1.27	-	-	0.050
W	-	-	1.53	-	-	0.060

XG402

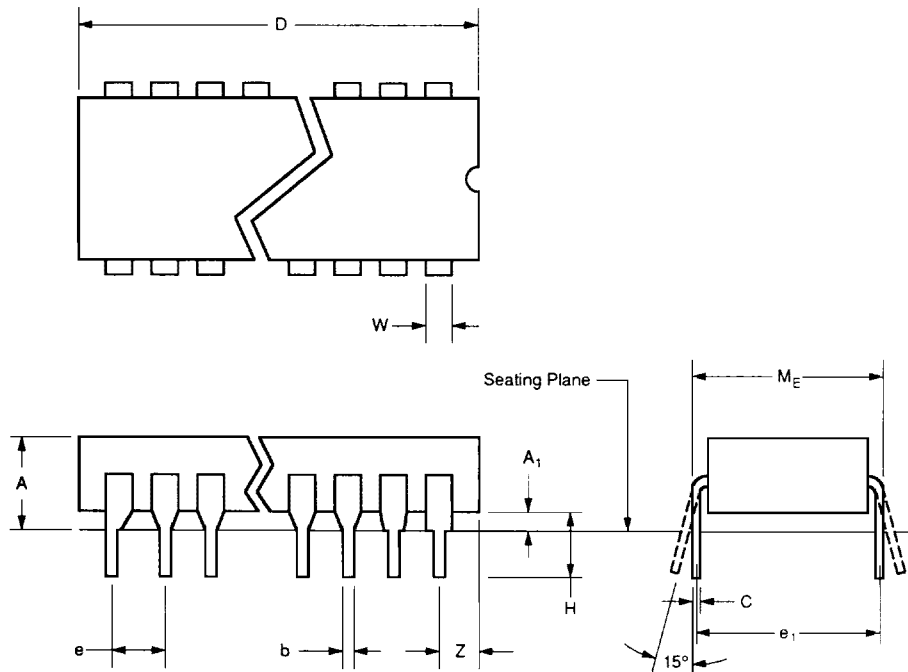

Figure 11: 16-Lead Ceramic DIL (Solder Seal) - Package Style C

Ref	Inches		
	Min.	Nom.	Max.
A	-	-	0.103
A1	0.026	-	-
b	0.015	-	0.019
c	0.004	-	0.006
D	0.392	-	0.408
e	-	0.050	-
L	0.250	-	0.305
M	0.264	-	0.276
E2	0.184	-	0.196
Z	0.005	-	-

XG534

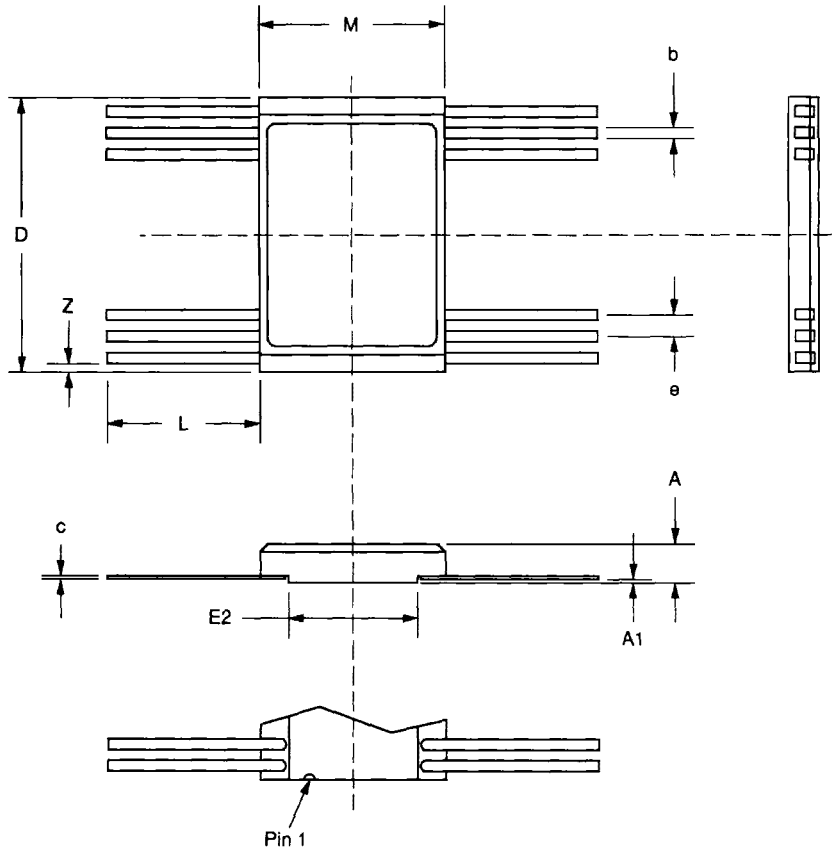

Figure 12: 16-Lead Bottom Braze Flatpack (Solder Seal) - Package Style F

15HSC Series

ORDERING INFORMATION

