

## Ceramic Disc Capacitors Class 1, 500 V (DC) Narrow Tolerance

### FEATURES

- Low losses
- High stability
- High capacitance in small size
- Kinked (preferred) or straight leads
- Lead (Pb)-free available



### APPLICATIONS

- Bypassing
- Coupling
- Resonant circuit.

### DESIGN

The capacitors consist of a ceramic disc both sides of which are silver-plated. Connection leads are made of tinned copper having a diameter of 0.6 mm.

The capacitors have inward kinked leads with a spacing of 5 mm (0.200") and a lead length from 4 to 30 mm. Encapsulation is made of phenolic resin.

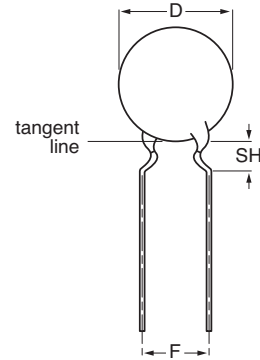

Capacitors with 5 mm (0.20") lead spacing.

### CAPACITANCE RANGE:

Class 1, at 1 MHz, 1.2 V (RMS); 1.0 pF to 330 pF  
1 kHz,  $1 \pm 0.2V$  (RMS) for capacitance values higher than 1000 pF.

### TEMPERATURE COEFFICIENTS:

Class 1 NP0; P100; N150; N750; N1500

### RATED DC VOLTAGE:

500 V

### SECTIONAL SPECIFICATIONS:

Class 1 IEC 60 384-8,  
EIA 198

### DIELECTRIC STRENGTH:

250 % of rated voltage

### CLIMATIC CATEGORY:

Class 1 55/125/21

### INSULATION RESISTANCE AT 500V (DC):

$\geq 10\,000\ M\Omega$

### OPERATING TEMPERATURE RANGE:

Class 1 - 55 to + 125 °C

### TOLERANCE ON CAPACITANCE:

$\pm 0.25\ pF$ ;  $\pm 2\ %$

### MARKING

Marking indicates capacitance value and tolerance in accordance with "EIA 198".

### DISSIPATION FACTOR:

Class 1,  $C \leq 30\ pF$ ;  $\leq 20 \times (10/C + 0.7) \times 10^{-4}$  maximum

Class 1,  $C > 30\ pF$ ;  $\leq 20 \times 10^{-4}$

The capacitors meet the essential requirements of "EIA 198". Unless stated otherwise all electrical values apply at an ambient temperature of  $25 \pm 3\ ^\circ C$ , at normal atmospheric conditions

# HV 500 V Narrow Tolerance

Vishay BCcomponents

Ceramic Disc Capacitors  
Class 1, 500 V (DC) Narrow Tolerance



<b>ORDERING INFORMATION, CLASS 1, 500 V (DC), KINKED</b>																
C (pF)	TOL. (%)	D <sub>max</sub> (mm)	LEAD SPACING F (mm)	SH <sup>(2)</sup> (mm)	CLEAR TEXT CODE	PACKAGING CODE 8 <sup>th</sup> AND 9 <sup>th</sup> DIGIT <sup>(3)</sup>			CATALOG NUMBER <sup>(4)</sup> 3 <sup>rd</sup> DIGIT: 5 = STANDARD, 8 = RoHS COMPLIANT							
					13 <sup>th</sup> DIGIT: T = REEL; U = AMMO; 3 = BULK 16 <sup>th</sup> DIGIT: R = RoHS COMPLIANT	REEL	AMMO	BULK								
<b>CLASS 1 P100</b>																
1.5	± 0.25	5.0	5.0	4.0	D159C20M7GL6.J5.	06	08	10	22.2 598 ..144							
2.2					D229C20M7GL6.J5.				22.2 598 ..244							
3.3					D339C20M7GL6.J5.				22.2 598 ..344							
4.7					D479C20M7GL6.J5.				22.2 598 ..444							
6.8					D689C25M7GL6.J5.				22.2 598 ..644							
10	± 2 %	6.5			D100G29M7GL6.J5.				22.2 598 ..004							
15		7.5			D150G33M7GL6.J5.				22.2 598 ..104							
22		8.5			D220G39M7GL6.J5.				22.2 598 ..204							
33		10.0			D330G47M7GL6.J5.				22.2 598 ..304							
		12.0														
<b>CLASS 1 NP0</b>																
1.0	± 0.25	5.0	5.0	4.0	D109C20C0KL6.J5.	06	08	10	22.2 508 ..044							
1.5					D159C20C0KL6.J5.				22.2 508 ..144							
2.2					D229C20C0JL6.J5.				22.2 508 ..244							
3.3					D339C20C0JL6.J5.				22.2 508 ..344							
4.7					D479C20C0HL6.J5.				22.2 508 ..444							
6.8					D689C20C0HL6.J5.				22.2 508 ..644							
10	± 2 %	6.5			D100G20C0GL6.J5.				22.2 508 ..004							
15					D150G20C0GL6.J5.				22.2 508 ..104							
22					D220G25C0GL6.J5.				22.2 508 ..204							
33					D330G25C0GL6.J5.				22.2 508 ..304							
47					D470G29C0GL6.J5.				22.2 508 ..404							
68					D680G33C0GL6.J5.				22.2 508 ..604							
100					7.5				D101G39C0GL6.J5.	22.2 508 ..014						
150					8.5				D151G47C0GL6.J5.	22.2 508 ..114						
					10.0											
					12.0											
<b>CLASS 1 N150</b>																
2.2					± 0.25				5.0	5.0	4.0	D229C20P2JL6.J5.	06	08	10	22.2 518 ..244
3.3	D339C20P2JL6.J5.	22.2 518 ..344														
4.7	D479C20P2HL6.J5.	22.2 518 ..444														
6.8	D689C20P2HL6.J5.	22.2 518 ..644														
10	± 2 %	6.5	D100G20P2GL6.J5.	22.2 518 ..004												
15			D150G20P2GL6.J5.	22.2 518 ..104												
22			D220G25P2GL6.J5.	22.2 518 ..204												
33			D330G25P2GL6.J5.	22.2 518 ..304												
47			D470G29P2GL6.J5.	22.2 518 ..404												
68			D680G33P2GL6.J5.	22.2 518 ..604												
100			7.5	D101G43P2GL6.J5.	22.2 518 ..014											
			8.5													
			11.0													



# HV 500 V Narrow Tolerance

Ceramic Disc Capacitors  
Class 1, 500 V (DC) Narrow Tolerance

Vishay BCcomponents

<b>ORDERING INFORMATION, CLASS 1, 500 V (DC), KINKED</b>									
C (pF)	TOL. (%)	D <sub>max</sub> (mm)	LEAD SPACING F (mm)	SH <sup>(2)</sup> (mm)	CLEAR TEXT CODE	PACKAGING CODE 8 <sup>th</sup> AND 9 <sup>th</sup> DIGIT <sup>(3)</sup>			CATALOG NUMBER <sup>(4)</sup> 3 <sup>rd</sup> DIGIT: 5 = STANDARD, 8 = RoHS COMPLIANT
					13 <sup>th</sup> DIGIT: T = REEL; U = AMMO; 3 = BULK 16 <sup>th</sup> DIGIT: R = RoHS COMPLIANT	REEL	AMMO	BULK	
<b>CLASS 1 N750</b>									
6.8	± 0.25	5.0	5.0	4.0	D689C20U2JL6.J5.	06	08	10	22.2 558 ..644
10	± 2 %				D100G20U2JL6.J5.				22.2 558 ..004
15					D150G20U2JL6.J5.				22.2 558 ..104
22					D220G20U2JL6.J5.				22.2 558 ..204
33					D330G25U2JL6.J5.				22.2 558 ..304
47					D470G29U2JL6.J5.				22.2 558 ..404
68					D680G33U2JL6.J5.				22.2 558 ..604
100					D101G39U2JL6.J5.				22.2 558 ..014
150					D151G47U2JL6.J5.				22.2 558 ..114
<b>CLASS 1 N1500</b>									
8.2	± 0.25 pF	5.0	5.0	4.0	D829C20P3KL6.J5.	06	08	10	22.2 588 ..844
10	± 2 %				D100G20P3KL6.J5.				22.2 588 ..004
15					D150G20P3KL6.J5.				22.2 588 ..104
22					D220G20P3KL6.J5.				22.2 588 ..204
33					D330G20P3KL6.J5.				22.2 588 ..304
47					D470G20P3KL6.J5.				22.2 588 ..404
68					D680G25P3KL6.J5.				22.2 588 ..604
100					D101G29P3KL6.J5.				22.2 588 ..014
150					D151G33P3KL6.J5.				22.2 588 ..114
220					D221G39P3KL6.J5.				22.2 588 ..214
330					D331G47P3KL6.J5.				22.2 588 ..314

**Notes**

1. Maximum thickness 4.0 mm.
2. SH = seated height.
3. Packaging codes refer to inward kinked leads. Other styles available on request.
4. 3<sup>rd</sup> digit to complete RoHS catalog number. 8<sup>th</sup> and 9<sup>th</sup> digit of the catalog number to be completed with the packaging code.
5. Other capacitance values E12 series available

<b>PACKAGING</b>				
D <sub>max</sub> (mm)	SIZE CODE	PACKAGING QUANTITIES		
		BULK	REEL	AMMO
5.0 (0.20")	20	1000	2000	2000
6.5 (0.25")	25			
7.5 (0.29")	29			
8.5 (0.33")	33			
10.0 (0.39")	39			
11.0 (0.43")	43			
12.0 (0.47")	47			

**Note**

1. The capacitors are supplied in bulk packaging (cardboard boxes), in tape on reel or in ammopack.

# HV 500 V Narrow Tolerance

Vishay BCcomponents

Ceramic Disc Capacitors  
Class 1, 500 V (DC) Narrow Tolerance

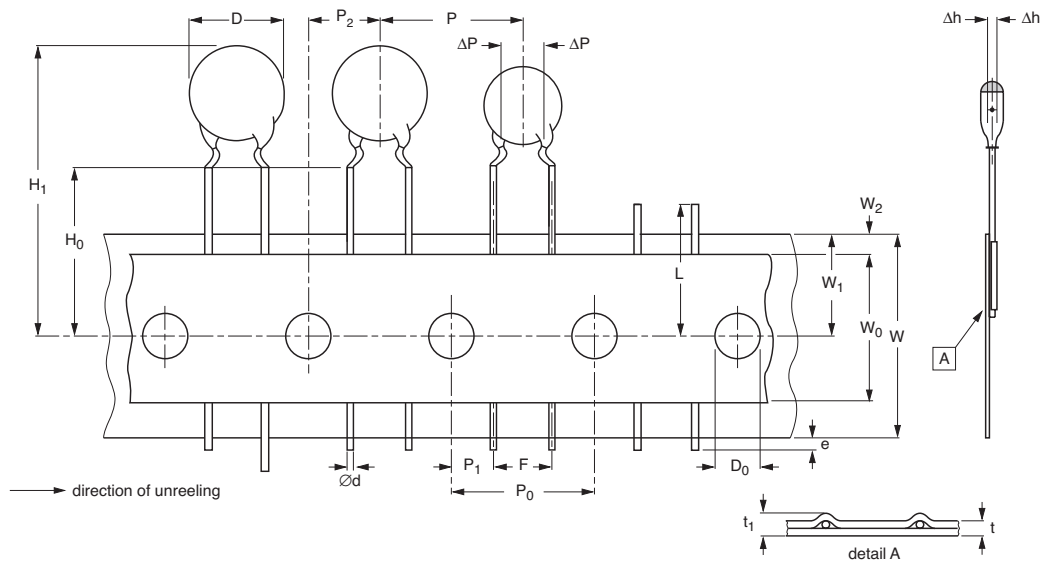

Kinked capacitors on tape, lead spacing 5.0 mm (0.2").

DIMENSIONS OF TAPE			
SYMBOL	PARAMETER	DIMENSIONS (mm)	
		NOMINAL	TOLERANCE
D	body diameter	11.0 maximum	-
d	lead diameter	0.6	± 0.05
P	pitch between capacitors	12.7	± 1.0
P <sub>0</sub>	feed-hole pitch	12.7	± 0.3; note 1
ΔP	plane deviation	1.0 maximum	-
P <sub>1</sub>	feed-hole centre to lead centre	3.85	± 0.7; note 2
P <sub>2</sub>	feed-hole centre to component centre	6.35	± 1.3; note 2
F	lead spacing	5.0	+ 0.6 - 0.4
Δh	component alignment	0	± 1.0
Δs	deviation along tape, left or right	0	± 1.0
W	tape width	18.0	+ 1.0 - 0.5
W <sub>0</sub>	hold-down tape width	5.0 minimum	-
W <sub>1</sub>	hole position	9.0	+ 0.75 - 0.5
W <sub>2</sub>	hold-down tape margin	3.0 maximum	-
H <sub>0</sub>	height to seating plane	16.0	± 0.5
H <sub>1</sub>	maximum component height	32.0	-
e	lead end protrusion	1.0 maximum	-
L	maximum length of snapped lead	11.0	-
D <sub>0</sub>	feed-hole diameter	4.0	± 0.2
t	total tape thickness	0.9 maximum	-
t <sub>1</sub>	maximum thickness of tape and wires	1.5 maximum	-

## Notes

1. Cumulative pitch error:  $\pm \leq 1$  mm /20 pitches.
2. Obliquity maximum 3°.



# HV 500 V Narrow Tolerance

Ceramic Disc Capacitors  
Class 1, 500 V (DC) Narrow Tolerance

Vishay BCcomponents

## REEL AND TAPE DATA in millimeters

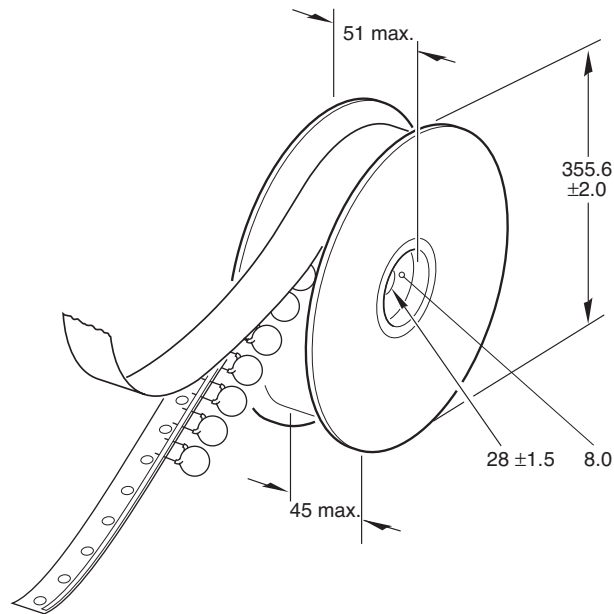

Reel with capacitors on tape.

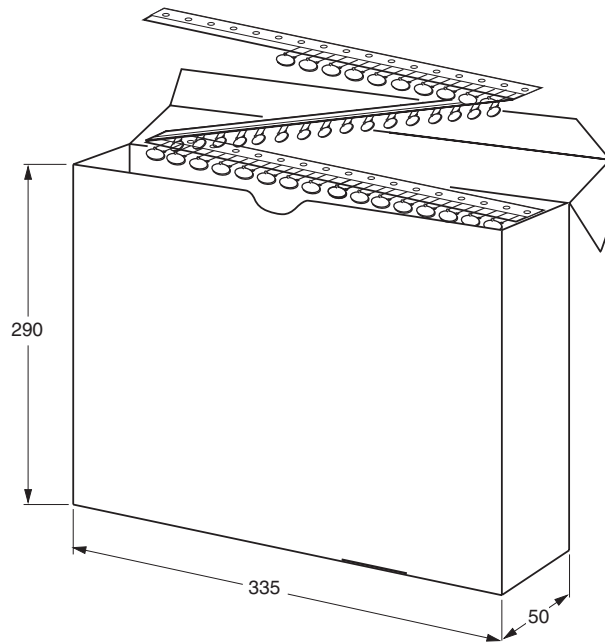

Ammopack with capacitors on tape.



## Notice

Specifications of the products displayed herein are subject to change without notice. Vishay Intertechnology, Inc., or anyone on its behalf, assumes no responsibility or liability for any errors or inaccuracies.

Information contained herein is intended to provide a product description only. No license, express or implied, by estoppel or otherwise, to any intellectual property rights is granted by this document. Except as provided in Vishay's terms and conditions of sale for such products, Vishay assumes no liability whatsoever, and disclaims any express or implied warranty, relating to sale and/or use of Vishay products including liability or warranties relating to fitness for a particular purpose, merchantability, or infringement of any patent, copyright, or other intellectual property right.

The products shown herein are not designed for use in medical, life-saving, or life-sustaining applications. Customers using or selling these products for use in such applications do so at their own risk and agree to fully indemnify Vishay for any damages resulting from such improper use or sale.