



SA9602M

SINGLE PHASE POWER/ENERGY METERING IC WITH SELECTABLE PULSE RATE FOR MECHANICAL DISPLAY APPLICATIONS

FEATURES

- Provides ease of interface to systems employing a mechanical counter
- Performs bidirectional power and energy measurement
- Meets the IEC 521/1036 Specification requirements for Class 1 AC Watt hour meters
- Protected against ESD
- Allows selection of motor driver configuration
- Total power consumption rating below 25mW
- Adaptable to different types of current sensors
- Operates over a wide temperature range
- Precision voltage reference on-chip
- Selectable pulse rate
- Scaling of rated conditions provides ease of implementation for meter manufactured.

DESCRIPTION

The SAMES SA9602M Single Phase bidirectional Power/Energy metering integrated circuit generates a pulse rate output, the frequency of which is proportional to the power consumption. The SA9602M performs the calculation for active power.

The method of calculation takes the power factor into account.

Energy consumption can be determined by counting output pulses. The pulse rate for a particular application is selected according to the status of inputs MP0 and MP1.

This innovative universal single phase power/energy metering integrated circuit is ideally suited for energy calculations in applications utilizing a mechanical display.

The SA9602M integrated circuit is available in 20 pin dual-in-line plastic (DIP-20), as well as 20 pin small outline (SOIC-20) package types.

PIN CONNECTIONS

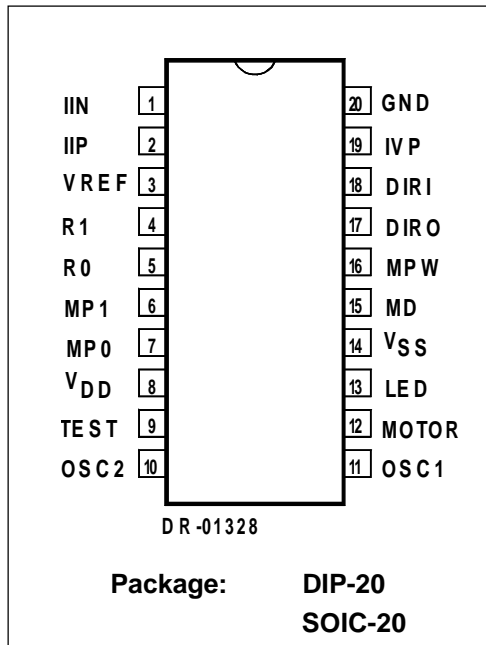

BLOCK DIAGRAM

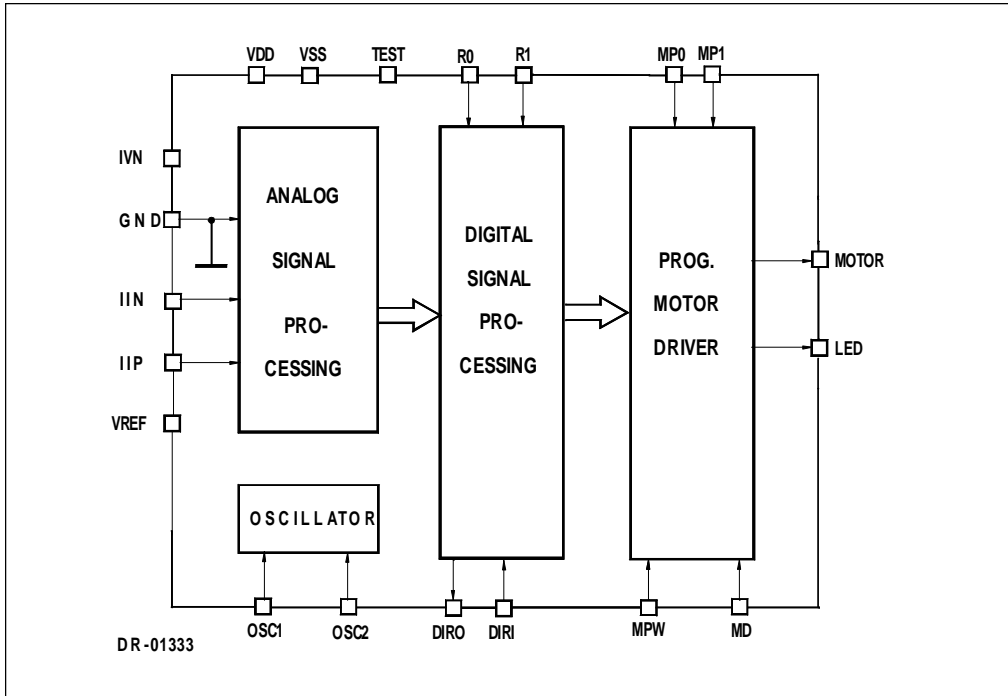

ABSOLUTE MAXIMUM RATINGS*

Parameter	Symbol	Min	Max	Unit
Supply Voltage	$V_{DD} - V_{SS}$	-0.3	6.0	V
Current on any pin	I_{PIN}	-150	+150	mA
Storage Temperature	T_{STG}	-40	+125	°C
Operating Temperature	T_O	-25	+85	°C

* Stresses above those listed under "Absolute Maximum Ratings" may cause permanent damage to the device. This is a stress rating only. Functional operation of the device at these or any other condition above those indicated in the operational sections of this specification, is not implied. Exposure to Absolute Maximum Ratings for extended periods may affect device reliability.

ELECTRICAL CHARACTERISTICS

($V_{DD} = 2.5V$, $V_{SS} = -2.5V$, over the temperature range $-10^{\circ}C$ to $+70^{\circ}C^{\#}$, unless otherwise specified.)

Parameter	Symbol	Min	Typ	Max	Unit	Condition
Operating temp. range	T_o	-25		+85	$^{\circ}C$	
Supply Voltage: Positive	V_{DD}	2.25		2.75	V	
Supply Voltage: Negative	V_{SS}	-2.75		-2.25	V	
Supply Current: Positive	I_{DD}		5	6	mA	
Supply Current: Negative	I_{SS}		5	6	mA	
Current Sensor Inputs (Differential)						
Input Current Range	I_{II}	-25		+25	μA	Peak value
Voltage Sensor Input (Asymmetrical)						
Input Current Range	I_{IV}	-25		+25	μA	Peak value
Pin R0, R1, Input High Voltage	V_{IH}	$V_{DD}-1$			V	Pull down
Input Low Voltage	V_{IL}			$V_{SS}+1$	V	
Pin MP0, MP1 Input High Voltage	V_{IH}	$V_{DD}-1$			V	Pull down
Input Low Voltage	V_{IL}			$V_{SS}+1$	V	
Pin MOTOR	V_{OH} V_{OL}	$V_{DD}-1$		$V_{SS}+1$	V V	Tri-state
Pin DIRO Output High Voltage	V_{OH}	$V_{DD}-1$			V	$I_{OH} = -2mA$ $I_{OL} = 5mA$
Output Low Voltage	V_{OL}			$V_{SS}+1$	V	
Pin DIRI Input High Voltage	V_{IH}	$V_{DD}-1$			V	Pull up
Input Low Voltage	V_{IL}			$V_{SS}+1$	V	
Pin LED Output High Voltage	V_{DH}	$V_{DD}-1$			V	$I_{OH} = -2mA$ $I_{OL} = 5mA$
Output Low Voltage	V_{OL}			$V_{SS}+1$	V	

SA9602M**ELECTRICAL CHARACTERISTICS (Continued)**

($V_{DD} = 2.5V$, $V_{SS} = -2.5V$, over the temperature range $-10^{\circ}C$ to $+70^{\circ}C^{\#}$, unless otherwise specified.)

Parameter	Symbol	Min	Typ	Max	Unit	Condition
Pin MD, MPW	V_{IH} V_{IL}	$V_{DD}-1$		$V_{SS}+1$	V V	Pull down
Pin VREF Ref. Current Ref. Voltage	$-I_R$ V_R	45 1.1	50	55 1.3	μA V	With $R = 24k\Omega$ connected to V_{SS} Referred to V_{SS}
Oscillator	Recommended crystal: TV colour burst crystal $f = 3.5795$ MHz					

Extended Operating Temperature Range available on request.

PIN DESCRIPTION

Pin	Designation	Description
20	GND	Ground
8	V_{DD}	Positive Supply Voltage
14	V_{SS}	Negative Supply Voltage
19	IVP	Analog input for Voltage
1	IIN	Inputs for current sensor
2	IIP	
3	VREF	Connection for current setting resistor
11	OSC1	Connections for crystal or ceramic resonator (OSC1 = Input ; OSC2 = Output)
10	OSC2	
12	MOTOR	Pulse rate output
13	LED	Pulse rate output
4	R1	Rated conditions select
5	R0	
6	MP1	Motor pulse rate select
7	MP0	
18	DIRI	Direction input
17	DIRO	Direction output
16	MPW	Motor pulse width select
15	MD	Motor driver configuration select
9	TEST	Manufacturer test pin. Connect to V_{SS} for normal operation.

FUNCTIONAL DESCRIPTION

The SA9602M is a CMOS mixed signal Analog/Digital integrated circuit, which performs power/energy calculations across a power range of 1000:1, to an overall accuracy of better than Class 1.

The integrated circuit includes all the required functions for 1-phase power and energy measurement such as two oversampling A/D converters for the voltage and current sense inputs, power calculation and energy integration. Internal offsets are eliminated through the use of cancellation procedures. The SA9602M generates pulses, the frequency of which is proportional to the power consumption. Two frequency outputs (MOTOR and LED) are available. The pulse rate follows the instantaneous power consumption measured.

The motor drive pin can be configured as a unipolar or bipolar output using input MD. This choice allows the manufacturer to use either an impulse counter (unipolar) or stepper motor (bipolar).

1. Power Calculation

In the Application Circuit (Figure 1), the voltage drop across the shunt will be between 0 and 16mV_{RMS} (0 to 80A through a shunt resistor of $200\mu\Omega$). This voltage is converted to a current of between 0 and $16\mu\text{A}_{\text{RMS}}$, by means of resistors R_1 and R_2 .

The current sense input saturates at an input current of $\pm 25\mu\text{A}$ peak.

For the voltage sensor input, the mains voltage (230VAC) is divided down through a divider to 14V_{RMS} . The current into the A/D converter input is set at $14\mu\text{A}_{\text{RMS}}$ at nominal mains voltage, via resistor R4 ($1\text{M}\Omega$).

Different pulse rates are available at the motor drive pin. The device may be programmed for a 1 pulse/kWh, 10 pulses/kWh or 100 pulses/kWh output, depending on the status of the motor pulse rate select pins MPD and MP1.

The LED pulse rate is fixed at 1000 pulses/kWh. The frequency of the motor drive and LED pin is dependant on the settings of R0 and R1 which allow selection of different rated conditions. Rated conditions such as 230V/40A, 230V/60A, 230V/80A and 230V/100A may be chosen. This facility allows meter manufacturers to cater for a wide range of metering applications with minimal design changes.

2. Analog Input Configuration

The input circuitry of the current and voltage sensor inputs are illustrated below.

These inputs are protected against electrostatic discharge through clamping diodes.

The feedback loops from the outputs of the amplifiers A_i and A_v generate virtual shorts on the signal inputs. Exact duplications of the input currents are generated for the analog signal processing circuitry.

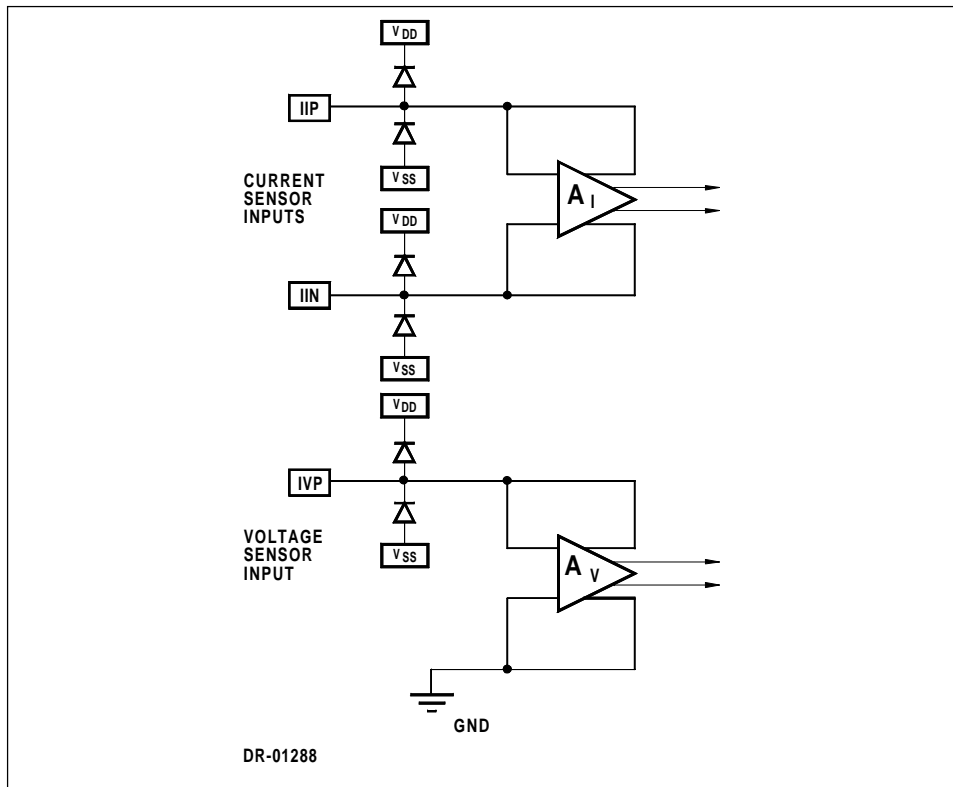

3. Electrostatic Discharge (ESD) Protection

The SA9602M integrated circuit's inputs/outputs are protected against ESD.

4. Power Consumption

The power consumption rating of the SA9602M integrated circuit is less than 30mW.

5. Output Signals

The motor drive output pulse is defined by the status of the MD input pin: MD=0 for unipolar; and MD=1 for bipolar. Note that the LED output pulses at a high frequency (1160Hz at rated conditions, irrespective of the R0, R1 inputs) when MD=0, this mode is very useful for fast calibration during manufacturing. The wave forms for the two types of output driving methods are show below:

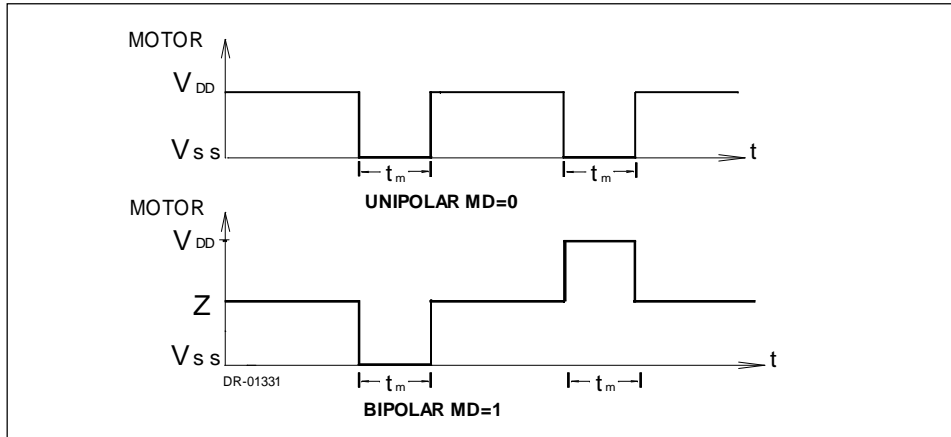
MOTOR DRIVE WAVEFORM

The pulse width for t_m is selected by the status of the motor pulse width input pin, MPW. The two possible options are shown in the following table.

MOTOR PULSE WIDTH, MPW

Signal	Motor pulse width input, MPW		Unit
	0	1	
t_m	37	71.4	ms

Note that wide pulses (MPW = 1) are not allowed with a high pulse rate specified by $R1 = 1$. The pulse rate of the motor driver output of the S9602M is selected by the inputs MP1 and MP0. Four pulse rate options are available as shown in tabular form below.

PULSE RATE SELECTION

Pulse Rate Selection Input		Motor drive output selection	Unit
MP1	MP0		
0	0	1	Wh/pulse
0	1	10	Wh/pulse
1	0	100	Wh/pulse
1	1	1000	Wh/pulse

SA9602M

The pulse rate of the LED output is fixed at 1000 pulses/kWh when MD = 1. This high rate of pulses is preferred for such tasks as calibration, verification and monitoring of consumption rate. The LED waveform is as shown below:

LED PULSE OUTPUT

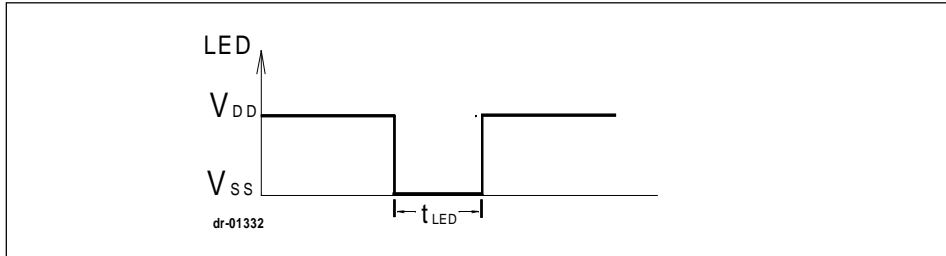

LED PULSE WIDTH

Signal	Motor driver configuration, MD	
	0	1
t_{LED}	71.4 μ s	10ms

6. Direction, Indication and Selection

The SA9602M provides information on the energy flow direction on pin DIRO.

A logic 0 on pin DIRO indicates reverse energy flow. Reverse energy flow is defined as the condition where the voltage sense input and current sense input are out of phase.

Positive energy flow, when voltage sense and current sense input are in phase, is indicated on pin DIRO a logic 1.

The DIRO pin may be used to drive a LED in order to indicate reverse energy.

DIRECTION INDICATION

Signal Output	Value	Description
DIRO	0	Reverse energy flow
	1	Forward energy flow

The SA9602M allows selection of the form of energy to be measured: forward energy, reverse energy, or bidirectional energy. Selection is achieved by means of the DIRI input. A table of possible settings for DIRI is shown below:

DIRECTION SELECTION

Signal Input DIRI	Description	Condition
0	Motor pulses only for reverse energy	
1	Motor pulses only for forward energy	Default pull up input
DIRO	Motor pulse for bidirectional energy	DIRO connected to DIRI

7. Rated Condition Select

The user selectable output frequencies for the MOTOR output and LED pulse rate will allow a meter manufacturer to build meters for a 5-4-3-2 scaling ratio of rated current.

The table below shows the various options which can be selected using pins R0 and R1.

RATED CONDITION SELECT

MD	R1	R0	Rated Conditions	LED Output (1000 pulses/kWh)
1	0	0	230V / 40A	2.55Hz
1	0	1	230V / 60A	3.83Hz
1	1	0	230V / 80A	5.11Hz
1	1	1	230V / 100A	6.39Hz

Scaling of the frequency for the MOTOR drive output pulses takes effect in the same manner as shown for the LED output pulse rate.

This feature is particularly useful in circumstances where a manufacturer requires a meter for use in a system rated for two different conditions, for example 230V/80A and 230V/40A. Previously such a requirement would have necessitated alteration of both the input current sensing resistors and the output measuring/counting block.

With the rated condition select, using R0 and R1, the SA9602M allows for the development of different rated meters requiring minimal changes.

SA9602M

For example, a meter manufacturer may wish to build

- (a) Meter rated for 230V/80A, 1000 pulses/kWh
- (b) Meter rated for 230V/40A, 1000 pulses/kWh

If the LED output pulse rate is considered, then

(a) 230V/80A, R1=1 and R0=0

The table of Rated Condition Select shows that for this case the frequency for the LED output at rated conditions is 5.11Hz.

Hence,

$$1 \text{ pulse} = \frac{VI}{f_p} = \frac{230 \times 80}{5.11} \approx 3600 \text{ Ws}$$

(b) 230V/40A, R1=0 and R0=0

The table of Rated Condition Select shows that in this case the frequency for the LED output at rated conditions is 2.55Hz

Hence,

$$1 \text{ pulse} = \frac{VI}{f_p} = \frac{230 \times 40}{2.55} \approx 3600 \text{ Ws}$$

As the examples shows, the SA9602M can be configured easily for use in meters for different rated systems. The only changes which must be implemented are: selection of current sense resistors for the expected rated load current; and selection of settings for R0 and R1.

TYPICAL APPLICATIONS

In the Application Circuits (Figures 1 and 2), the components required for power metering applications, are shown.

In Figure 1 a shunt resistor is used for current sensing. In this application, the circuitry requires a +2.5V, 0V, -2.5V DC supply.

In the case of Figure 2, when using a current transformer for current sensing, a +5V, 0V DC supply is sufficient.

The most important external components for the SA9602M integrated circuit are:

R_2 , R_1 and RSH are the resistors defining the current level into the current sense input. The values should be selected for an input current of $16\mu A_{RMS}$ into the SA9602M at maximum line current.

Values for RSH of less than $200\mu\Omega$ should be avoided.

$$R_1 = R_2 = (I_L / 16\mu A_{RMS}) * R_{SH} / 2$$

Where I_L = Line current
RSH = Shunt resistor/termination resistor

R_3 , R_6 and R_4 set the current for the voltage sense input. The values should be selected so that the input current into the voltage sense input (virtual ground) is set to $14\mu A_{RMS}$. R_7 defines all on-chip bias and reference currents. With $R_7 = 24k\Omega$, optimum conditions are set. R_7 may be varied within $\pm 10\%$ for calibration purposes. Any change to R_7 will affect the output quadratically (i.e.: $R_7 = +5\%$, $f_p = +10\%$).

The formula for calculating the output frequency is given below:

$$f_{LED} = 11.16 * FOUTX * \frac{FOSC}{3.58MHz} * \frac{I_I \cdot I_V}{I_R^2}$$

Where FOUTX = Frequency for selected rated condition

FOSC = Oscillator frequency (2MHz 4MHz)

I_I = Input current for current input ($16\mu A_{RMS}$ at rated)

I_V = Input current for voltage input ($14\mu A_{RMS}$ at rated)

I_R = Reference current (typically $50\mu A$)

XTAL is a colour burst TV crystal ($f = 3.5795$ MHz) for the oscillator. The oscillator frequency is divided down to 1.7897 MHz on-chip, to supply the digital circuitry and the A/D converters.

Figure 1: Application Circuit see specification for details.

Specifications:

- Shunt resistor for current sensing.
- Rated conditions 230V/80A.
- Bidirectional metering.
- Motor step of 1Wh/pulse.
- Bipolar Motor.
- 37ms Motor pulses.

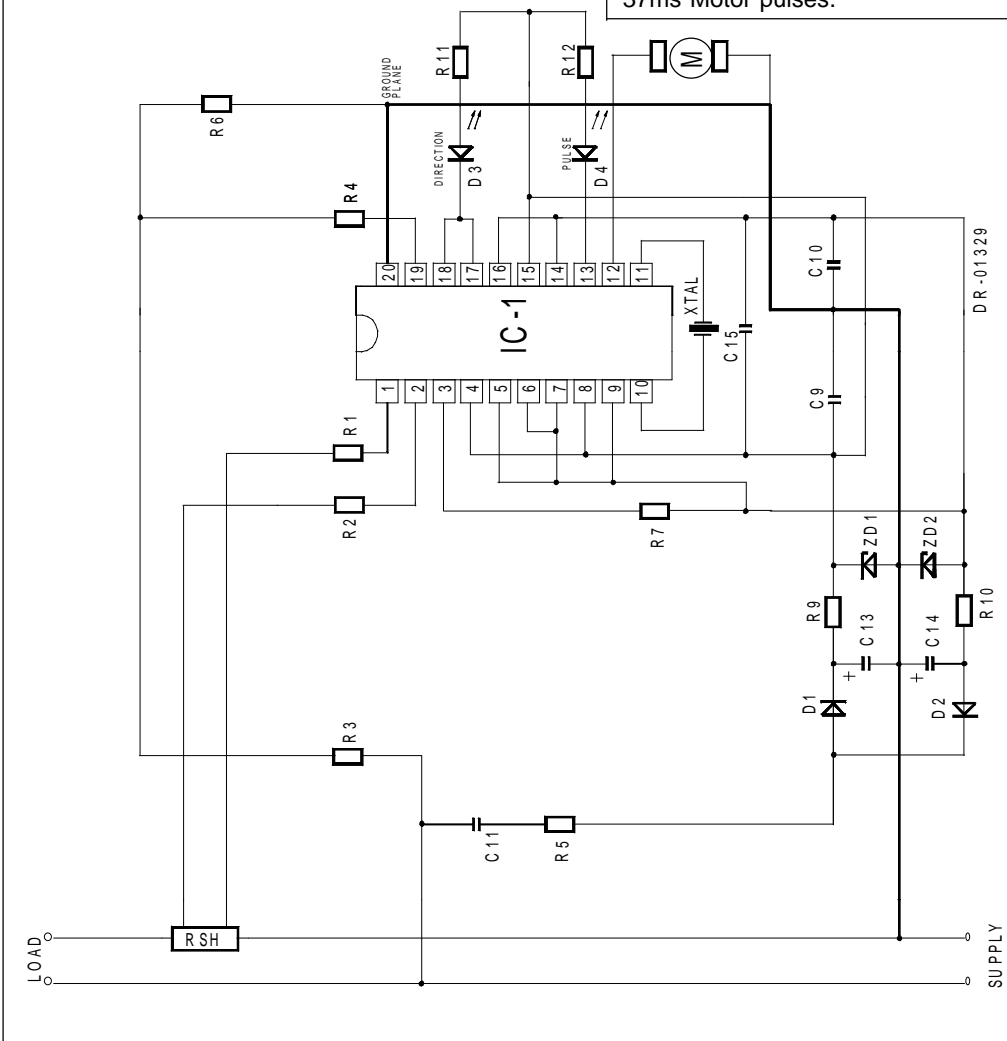

Parts List for Application Circuit: Figure 1

Item	Symbol	Description	Detail
1	IC-1	SA9602M	DIP-20/SOIC-20
2	D1	Diode, Silicon, 1N4148	
3	D2	Diode, Silicon, 1N4148	
4	ZD1	Diode, Zener, 2.4V, 200mW	
5	ZD2	Diode, Zener, 2.4V, 200mW	
6	D3	Light emitting diode	
7	D4	Light emitting diode	
8	XTAL	Crystal, 3.5795MHz	Colour burst TV
9	R1	Resistor, 1% metal	Note 1
10	R2	Resistor, 1% metal	Note 1
11	R3	Resistor, 390k, (230VAC) 1%, metal	
12	R4	Resistor, 1M, 1/4W, 1%, metal	
13	R5	Resistor, 470Ω, 2W, 5%, carbon	
14	R6	Resistor, 24k, 1/4W, 1%, metal	
15	R7	Resistor, 24k, 1/4W, 1%, metal	
16	R9	Resistor, 680Ω, 1/4W, 1%	
17	R10	Resistor, 680Ω, 1/4W, 1%	
18	R11	Resistor, 1k, 1/4W, 5% carbon	
19	R12	Resistor, 1k, 1/4W, 5% carbon	
20	C9	Capacitor, 100nF	Note 4
21	C10	Capacitor, 100nF	Note 4
22	C11	Capacitor, 0.47μF, 250VAC, polyester	
23	C13	Capacitor, 100μF	
24	C14	Capacitor, 100μF	
25	C15	Capacitor, 820nF	Note 2
26	RSH	Shunt Resistor	Note 8

Note 1: Resistor (R1 and R2) values are dependant upon the selected value of RSH.

Note 2: Capacitor (C15) to be positioned as close to Supply Pins (V_{DD} & V_{SS}) of IC-1 as possible.

Note 3: See TYPICAL APPLICATIONS when selecting the value of RSH.

Note 4: Additional Capacitors may be required depending on the change needed to step the motor.

Figure 2: Application circuit see specification for details.

Specification

- Current transformer for current sensing
- Rated conditions 230V/40A
- Unidirectional metering phase reversal indication
- Motor step at 10 steps/kWh
- Impulse counter
- Motor step at wide pulses.

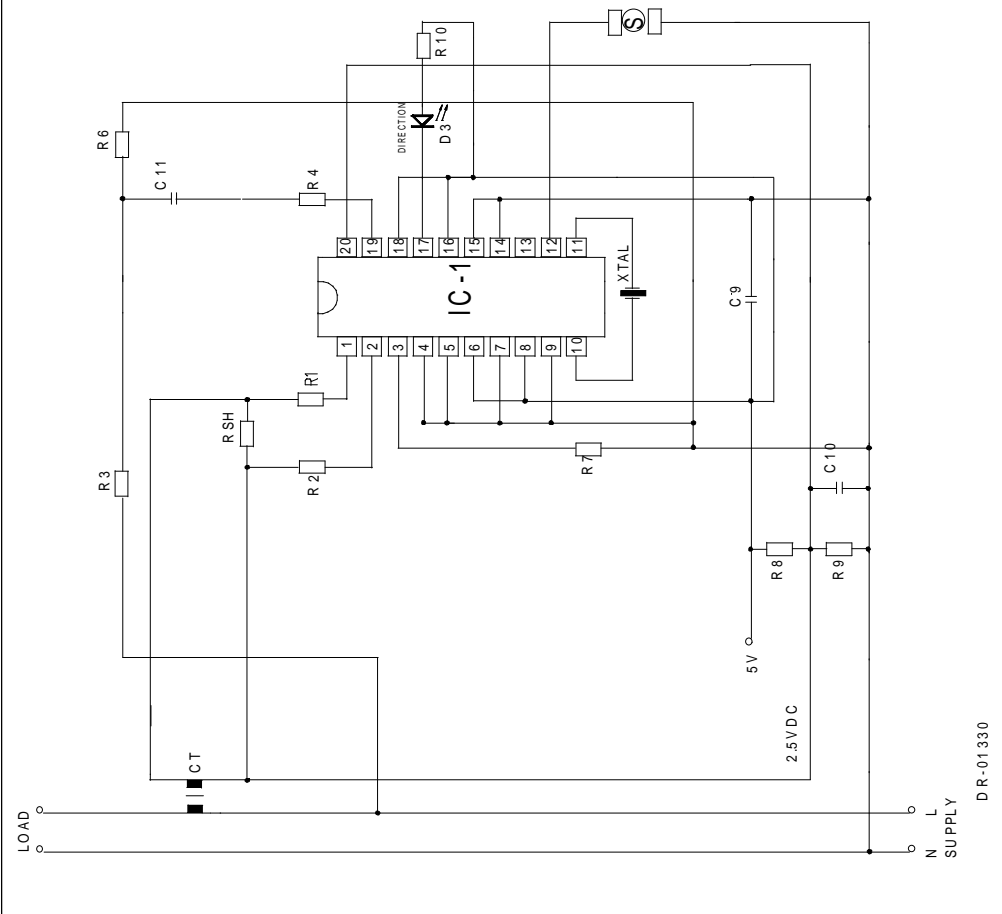

DR-01330

Parts List for Application Circuit: Figure 2

Item	Symbol	Description	Detail
1	IC-1	SA9602M	DIP-20/SOIC-20
2	XTAL	Crystal, 3.5795MHz	Colour burst TV
3	RSH	Resistor	Note 1
4	R1	Resistor, 1%, metal	Note 2
5	R2	Resistor, 1%, metal	Note 2
6	R3	Resistor, 390k, (230VAC), 1%, metal	
7	R4	Resistor, 1M, 1/4W, 1%, metal	
8	R6	Resistor, 24k, 1/4W, metal	
9	R7	Resistor, 24k, 1/4W, 1%, metal	
10	R8	Resistor, 2.2k, 1/4W, 1%, metal	
11	R10	Resistor 1K, 1/4W, 5% carbon	
12	R9	Resistor, 2.2k, 1/4W, 1%, metal	
13	C9	Capacitor, 820nF	Note 3
14	C10	Capacitor, 100nF	
15	C11	Capacitor	Note 4
16	CT	Current transformer	
17	D1	Light emitting diode	

Note 1: See TYPICAL APPLICATIONS when selecting the value of RSH.

Note 2: Resistor (R1 and R2) values are dependant upon the selected value of RSH.

Note 3: Capacitor (C9) to be positioned as close to Supply Pins (V_{DD} & V_{SS}) of IC-1, as possible.

Note 4: Capacitor (C11) selected to minimize phase error introduced by current transformer (typically 1.5 μ F).

ORDERING INFORMATION

Part Number	Package
SA9602MPA	DIP-20
SA9602MSA	SOIC-20

SA9602M

Disclaimer: The information contained in this document is confidential and proprietary to South African Micro-Electronic Systems (Pty) Ltd ("SAMES") and may not be copied or disclosed to a third party, in whole or in part, without the express written consent of SAMES. The information contained herein is current as of the date of publication; however, delivery of this document shall not under any circumstances create any implication that the information contained herein is correct as of any time subsequent to such date. SAMES does not undertake to inform any recipient of this document of any changes in the information contained herein, and SAMES expressly reserves the right to make changes in such information, without notification, even if such changes would render information contained herein inaccurate or incomplete. SAMES makes no representation or warranty that any circuit designed by reference to the information contained herein, will function without errors and as intended by the designer.

Any Sales or technical questions may be posted to our e-mail address below:
energy@sames.co.za

For the latest updates on datasheets, please visit our web site:
<http://www.sames.co.za>.

South African Micro-Electronic Systems (Pty) Ltd

P O Box 15888, Lynn East, 0039 Republic of South Africa,	33 Eland Street, Koedoespoort Industrial Area, Pretoria, Republic of South Africa
--	--

Tel: 012 333-6021
Fax: 012 333-8071

Tel: Int +27 12 333-6021
Fax: Int +27 12 333-8071