

Aluminum Capacitors + 105 °C, Tubular Radial Lead

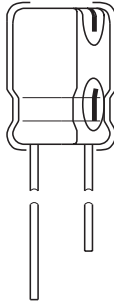

Fig.1 Component outline.

FEATURES

- Wide temperature range
- Radial design in two and three lead configuration
- Ideal SMPS output filter



QUICK REFERENCE DATA	
DESCRIPTION	VALUE
Nominal case size ØD x L in mm	0.75" x 1.125" [1.905 x 28.575] to 1.0" x 3.626" [25.4 x 92.075]
Operating temperature	- 55 °C to + 105 °C
Rated Capacitance range, C _R	27 µF to 27000 µF
Tolerance on C _R	- 10 %, + 50 %
Rated voltage range, U _R	6.3 WVDC to 250 WVDC
Termination	Radial leads
Life validation test at + 105 °C	2000 hours: Δ CAP ≤ 15 % from initial measurement. Δ ESR ≤ 1.5 x initial specified limit. Δ DCL ≤ initial specified limit.
Shelf life at + 105 °C	500 hours: Δ CAP ≤ 10 % from initial measurement. Δ ESR ≤ 1.15 x initial specified limit. Δ DCL ≤ 2 x initial specified limit
DC leakage current at + 25 °C	$I = K \sqrt{CV}$ K = 0.5 I in µA, C in µF, V in Volts

RIPPLE CURRENT MULTIPLIERS					
TEMPERATURE					
Ambient Temperature		Multipliers			
+ 105 °C		0.4			
+ 85 °C		1.0			
+ 65 °C		1.4			
+ 45 °C		1.7			
+ 25 °C		2.0			
FREQUENCY (Hz)					
Rated WVDC	50 - 60	100 - 120	300 - 400	1000	20000
0 - 60	0.60	0.75	0.80	0.90	1.0
61 - 250	0.43	0.54	0.75	0.85	1.0

LOW TEMPERATURE PERFORMANCE			
CAPACITANCE RATIO C - 55 °C / C + 25 °C MINIMUM AT 120 Hz			
Rated Voltage (WVDC)	6.3 - 25	40 - 100	150 - 250
Capacitance Remaining	75 %	80 %	65 %
ESR RATIO ESR - 55 °C / ESR + 25 °C MAXIMUM AT 120 Hz			
Rated Voltage (WVDC)	0 - 12	13 - 40	41 - 250
Multipliers	8	10	16
ESL (TYPICAL VALUES AT 1 MHz TO 10 MHz)			
Nominal Diameter	0.75 [19.0]	0.875 [22.0]	1.00 [25.0]
Typical ESL (nH)	10	11	13

DIMENSIONS in inches [millimeters]					
CASE CODE	STYLE 1 STYLE 7		OVERALL LENGTH H (Max.)	LEAD SPACING* S ± 0.015 [0.4]	TYPICAL WEIGHT Oz. (Grams)
	D ± 0.015 [0.4]	L ± 0.062 [1.6]			
GE	0.770 [19.6]	1.150 [29.2]	1.246 [31.6]	0.250 [6.4]	0.46 (13)
GJ	0.770 [19.6]	1.650 [41.9]	1.746 [44.3]	0.250 [6.4]	0.67 (19)
GL	0.770 [19.6]	2.150 [54.6]	2.246 [57.0]	0.250 [6.4]	0.74 (21)
GP	0.770 [19.6]	2.650 [67.3]	2.746 [69.7]	0.250 [6.4]	0.88 (25)
GS	0.770 [19.6]	3.150 [80.0]	3.246 [82.4]	0.250 [6.4]	1.16 (33)
GT	0.770 [19.6]	3.650 [92.7]	3.746 [95.1]	0.250 [6.4]	1.34 (38)
HE	0.895 [22.7]	1.150 [29.2]	1.246 [31.6]	0.300 [7.6]	0.63 (18)
HJ	0.895 [22.7]	1.650 [41.9]	1.746 [44.3]	0.300 [7.6]	0.95 (27)
HL	0.895 [22.7]	2.150 [54.6]	2.246 [57.0]	0.300 [7.6]	1.02 (29)
HP	0.895 [22.7]	2.650 [67.3]	2.746 [69.7]	0.300 [7.6]	1.37 (39)

U673D and U674D

Vishay Sprague

Aluminum Capacitors
+ 105 °C, Tubular Radial Lead



DIMENSIONS in inches [millimeters]					
CASE CODE	STYLE 1 STYLE 7		OVERALL LENGTH H (Max.)	LEAD SPACING* S ± 0.015 [0.4]	TYPICAL WEIGHT Oz. (Grams)
	D ± 0.015 [0.4]	L ± 0.062 [1.6]			
HS	0.895 [22.7]	3.150 [80.0]	3.246 [82.4]	0.300 [7.6]	1.73 (49)
HT	0.895 [22.7]	3.650 [92.7]	3.746 [95.1]	0.300 [7.6]	2.08 (59)
JE	1.020 [25.9]	1.150 [29.2]	1.246 [31.6]	0.400 [10.2]	0.81 (23)
JJ	1.020 [25.9]	1.650 [41.9]	1.746 [44.3]	0.400 [10.2]	1.02 (29)
JL	1.020 [25.9]	2.150 [54.6]	2.246 [57.0]	0.400 [10.2]	1.20 (34)
JP	1.020 [25.9]	2.650 [67.3]	2.746 [69.7]	0.400 [10.2]	1.87 (53)
JS	1.020 [25.9]	3.150 [80.0]	3.246 [82.4]	0.400 [10.2]	2.22 (63)
JT	1.020 [25.9]	3.650 [92.7]	3.746 [95.1]	0.400 [10.2]	2.54 (72)

* Type U673D only.

LEAD SPACING				
CASE DIAMETER	A	B	C ₁	C ₂
0.750 [19.1]	0.300 [7.6]	0.167 [4.23]	0.100 [2.5]	0.200 [5.1]
0.875 [22.2]	0.400 [10.2]	0.228 [5.79]	0.150 [3.8]	0.300 [7.6]
1.000 [25.4]	0.400 [10.2]	0.228 [5.79]	0.150 [3.8]	0.300 [7.6]

DIMENSIONS in inches [millimeters] AND AVAILABLE FORMS

Terminal Code C

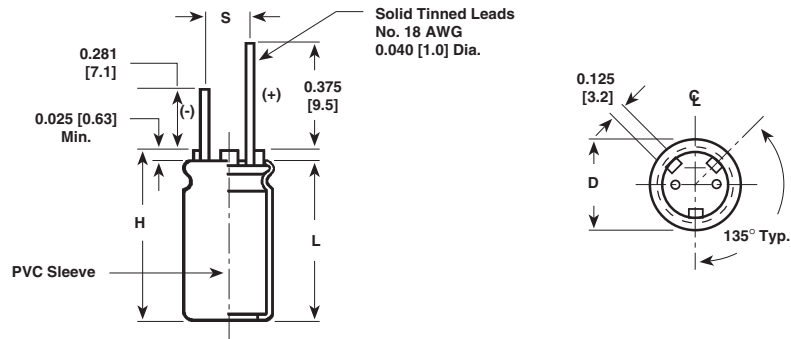
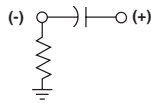

Terminal Code J

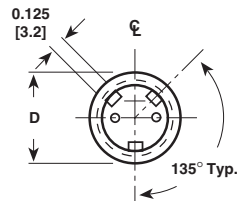
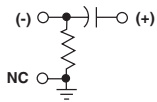

Terminal Code A

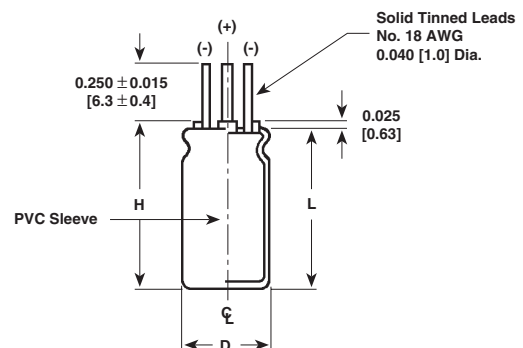
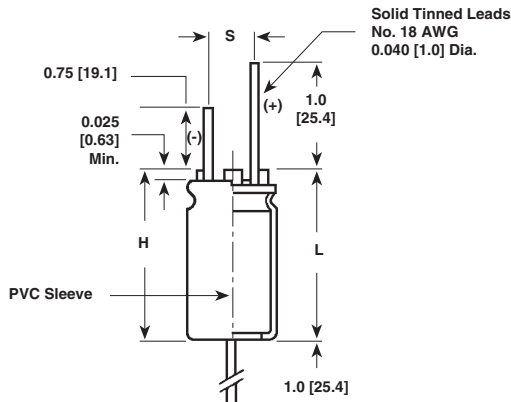
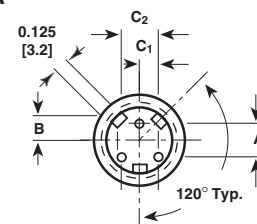
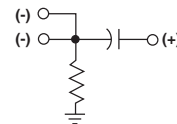



ELECTRICAL DATA	
SYMBOL	DESCRIPTION
μF	rated capacitance
± %	F = - 10 %, + 50 %; H = - 10 %, + 100 %
DC	voltage rating at 105 °C
GE	see dimensions in millimeters table
1	PVC Sleeve
C	termination

ORDERING EXAMPLE*

Electrolytic capacitor U673D and U674D series

U673D 222 F 6R3 GE 1C

*Note: For lead (Pb)-free, add suffix E3 to part number.

Example: U673D222F6R3GE1CE3

STANDARD RATINGS in inches [millimeters]						
CAPACITANCE E (μF)	PART NUMBER	NOMINAL CASE SIZE D x L	Max. ESR at + 25 °C (mΩ)		Max. RIPPLE at + 105 °C (A) 20 kHz - 40 kHz	Max. Z at 100 kHz (mΩ)
			120 Hz	20 kHz - 40 kHz		
6.3 WVDC at 105 °C, SURGE = 9 V						
2200.0	U673D228F6R3GE1C	0.770 x 1.150 [19.6 x 29.2]	105.0	81.0	2.30	83.0
4700.0	U673D478F6R3GJ1C	0.770 x 1.650 [19.6 x 41.9]	53.0	41.0	3.70	43.0
6800.0	U673D688F6R3GL1C	0.770 x 2.150 [19.6 x 54.6]	36.0	28.0	4.95	30.0
8200.0	U673D828F6R3GP1C	0.770 x 2.650 [19.6 x 67.3]	28.0	22.7	6.11	25.0
10000.0	U673D109F6R3GS1C	0.770 x 3.150 [19.6 x 80.0]	23.0	19.0	7.20	21.0
12000.0	U673D129F6R3GT1C	0.770 x 3.650 [19.6 x 92.7]	21.0	17.0	8.14	19.0
3300.0	U673D338F6R3HE1C	0.895 x 1.150 [22.7 x 29.2]	74.0	58.0	3.00	60.0
6800.0	U673D688F6R3HJ1C	0.895 x 1.650 [22.7 x 41.9]	38.0	39.0	4.73	41.0
10000.0	U673D109F6R3HL1C	0.895 x 2.150 [22.7 x 54.6]	27.0	22.0	6.20	24.0
15000.0	U673D159F6R3HP1C	0.895 x 2.650 [22.7 x 67.3]	21.0	17.4	7.62	19.0
18000.0	U673D189F6R3HS1C	0.895 x 3.150 [22.7 x 80.0]	18.0	15.0	8.83	17.0
22000.0	U673D229F6R3HT1C	0.895 x 3.650 [22.7 x 92.7]	15.8	13.3	10.10	15.0
4700.0	U673D478F6R3JE1C	1.020 x 1.150 [25.9 x 29.2]	60.0	48.0	3.60	50.0
10000.0	U673D109F6R3JJ1C	1.020 x 1.650 [25.9 x 41.9]	32.0	26.0	5.54	28.0
15000.0	U673D159F6R3JL1C	1.020 x 2.150 [25.9 x 54.6]	22.6	18.8	7.30	21.0
18000.0	U673D189F6R3JP1C	1.020 x 2.650 [25.9 x 67.3]	18.0	15.2	8.81	17.0
22000.0	U673D229F6R3JS1C	1.020 x 3.150 [25.9 x 80.0]	15.4	13.0	10.20	14.0
27000.0	U673D279F6R3JT1C	1.020 x 3.650 [25.9 x 92.7]	13.4	11.5	11.60	13.0
7.5 WVDC at 105 °C, SURGE = 10 V						
1800.0	U673D188F7R5GE1C	0.770 x 1.150 [19.6 x 29.2]	110.0	82.0	2.30	84.0
3900.0	U673D398F7R5GJ1C	0.770 x 1.650 [19.6 x 41.9]	55.0	41.0	3.70	52.0
5600.0	U673D568F7R5GL1C	0.770 x 2.150 [19.6 x 54.6]	38.0	29.0	4.93	31.0
8200.0	U673D828F7R5GP1C	0.770 x 2.650 [19.6 x 67.3]	29.5	22.8	6.10	25.0
10000.0	U673D109F7R5GS1C	0.770 x 3.150 [19.6 x 80.0]	25.8	20.0	7.04	22.0
12000.0	U673D129F7R5GT1C	0.770 x 3.650 [19.6 x 92.7]	22.0	17.4	8.06	19.0
3300.0	U673D338F7R5HE1C	0.895 x 1.150 [22.7 x 29.2]	76.0	58.4	2.97	61.0
5600.0	U673D568F7R5HJ1C	0.895 x 1.650 [22.7 x 41.9]	39.5	30.6	4.72	33.0
8200.0	U673D828F7R5HL1C	0.895 x 2.150 [22.7 x 54.6]	27.7	21.8	6.23	24.0
12000.0	U673D129F7R5HP1C	0.895 x 2.650 [22.7 x 67.3]	22.0	17.6	7.58	20.0
15000.0	U673D159F7R5HS1C	0.895 x 3.150 [22.7 x 80.0]	18.7	15.0	8.82	17.0
18000.0	U673D189F7R5HT1C	0.895 x 3.650 [22.7 x 92.7]	16.4	13.5	9.97	15.0
3900.0	U673D398F7R5JE1C	1.020 x 1.150 [25.9 x 29.2]	62.0	48.0	3.55	50.0
8200.0	U673D828F7R5JJ1C	1.020 x 1.650 [25.9 x 41.9]	32.0	25.9	5.56	28.0
12000.0	U673D129F7R5JL1C	1.020 x 2.150 [25.9 x 54.6]	23.5	19.0	7.22	21.0
18000.0	U673D189F7R5JP1C	1.020 x 2.650 [25.9 x 67.3]	18.3	15.0	8.83	17.0
22000.0	U673D229F7R5JS1C	1.020 x 3.150 [25.9 x 80.0]	15.8	13.0	10.20	15.0
27000.0	U673D279F7R5JT1C	1.020 x 3.650 [25.9 x 92.7]	13.8	11.6	11.60	13.0

U673D and U674D

Vishay Sprague

Aluminum Capacitors
+ 105 °C, Tubular Radial Lead



STANDARD RATINGS in inches [millimeters]						
CAPACITANCE E (μ F)	PART NUMBER	NOMINAL CASE SIZE D x L	Max. ESR at + 25 °C ($m\Omega$)		Max. RIPPLE at + 105 °C (A) 20 kHz - 40 kHz	Max. Z at 100 kHz ($m\Omega$)
			120 Hz	20 kHz - 40 kHz		
10 WVDC at + 105 °C, SURGE = 12 V						
1800.0	U673D188F010GE1C	0.770 x 1.150 [19.6 x 29.2]	123.0	89.0	2.20	91.0
3300.0	U673D338F010GJ1C	0.770 x 1.650 [19.6 x 41.9]	60.0	44.0	3.56	46.0
5600.0	U673D568F010GL1C	0.770 x 2.150 [19.6 x 54.6]	41.0	30.0	4.79	32.0
6800.0	U673D688F010GP1C	0.770 x 2.650 [19.6 x 67.3]	31.0	24.0	5.93	26.0
8200.0	U673D828F010GS1C	0.770 x 3.150 [19.6 x 80.0]	26.0	20.0	7.02	22.0
10000.0	U673D109F010GT1C	0.770 x 3.650 [19.6 x 92.7]	23.0	17.8	7.97	20.0
2700.0	U673D278F010HE1C	0.895 x 1.150 [22.7 x 29.2]	82.0	61.0	2.90	62.0
5600.0	U673D568F010HJ1C	0.895 x 1.650 [22.7 x 41.9]	42.0	32.0	4.61	34.0
8200.0	U673D828F010HL1C	0.895 x 2.150 [22.7 x 54.6]	29.6	22.0	6.11	24.0
10000.0	U673D109F010HP1C	0.895 x 2.650 [22.7 x 67.3]	24.0	18.0	7.33	20.0
12000.0	U673D129F010HS1C	0.895 x 3.150 [22.7 x 80.0]	19.9	15.8	8.63	17.0
15000.0	U673D159F010HT1C	0.895 x 3.650 [22.7 x 92.7]	17.3	13.8	9.85	16.0
3900.0	U673D398F010JE1C	1.020 x 1.150 [25.9 x 29.2]	66.6	50.0	3.47	52.0
6800.0	U673D688F010JJ1C	1.020 x 1.650 [25.9 x 41.9]	34.0	26.7	5.48	29.0
12000.0	U673D129F010JL1C	1.020 x 2.150 [25.9 x 54.6]	24.0	19.0	7.18	21.0
15000.0	U673D159F010JP1C	1.020 x 2.650 [25.9 x 67.3]	19.2	15.0	8.72	17.0
18000.0	U673D189F010JS1C	1.020 x 3.150 [25.9 x 80.0]	16.0	13.0	10.20	15.0
22000.0	U673D229F010JT1C	1.020 x 3.650 [25.9 x 92.7]	14.3	11.8	11.50	14.0
12 WVDC at + 105 °C, SURGE = 16 V						
1500.0	U673D158F012GE1C	0.770 x 1.150 [19.6 x 29.2]	119.0	83.0	2.26	85.0
3300.0	U673D338F012GJ1C	0.770 x 1.650 [19.6 x 41.9]	60.0	42.0	3.65	44.0
4700.0	U673D478F012GL1C	0.770 x 2.150 [19.6 x 54.6]	41.0	29.0	4.88	31.0
6800.0	U673D688F012GP1C	0.770 x 2.650 [19.6 x 67.3]	31.0	23.0	6.07	26.0
8200.0	U673D828F012GS1C	0.770 x 3.150 [19.6 x 80.0]	26.0	19.4	7.14	22.0
10000.0	U673D109F012GT1C	0.770 x 3.650 [19.6 x 92.7]	23.0	17.0	8.11	20.0
2200.0	U673D228F012HE1C	0.895 x 1.150 [22.7 x 29.2]	83.0	60.0	2.93	62.0
4700.0	U673D478F012HJ1C	0.895 x 1.650 [22.7 x 41.9]	42.0	31.0	4.69	33.0
6800.0	U673D688F012HL1C	0.895 x 2.150 [22.7 x 54.6]	29.0	22.0	6.20	25.0
10000.0	U673D109F012HP1C	0.895 x 2.650 [22.7 x 67.3]	24.0	18.3	7.43	21.0
12000.0	U673D129F012HS1C	0.895 x 3.150 [22.7 x 80.0]	19.7	15.0	8.82	18.0
15000.0	U673D159F012HT1C	0.895 x 3.650 [22.7 x 92.7]	17.0	13.3	10.10	16.0
3300.0	U673D338F012JE1C	1.020 x 1.150 [25.9 x 29.2]	66.0	49.0	3.53	52.0
6800.0	U673D688F012JJ1C	1.020 x 1.650 [25.9 x 41.9]	34.0	26.0	5.54	29.0
10000.0	U673D109F012JL1C	1.020 x 2.150 [25.9 x 54.6]	25.5	19.0	7.12	22.0
12000.0	U673D129F012JP1C	1.020 x 2.650 [25.9 x 67.3]	19.7	15.0	8.75	18.0
18000.0	U673D189F012JS1C	1.020 x 3.150 [25.9 x 80.0]	16.4	13.0	10.20	16.0
22000.0	U673D229F012JT1C	1.020 x 3.650 [25.9 x 92.7]	14.6	11.8	11.50	15.0
16 WVDC at 105 °C, SURGE = 20 V						
1200.0	U673D128F016GE1C	0.770 x 1.150 [19.6 x 29.2]	129.0	83.0	2.24	85.0
2700.0	U673D278F016GJ1C	0.770 x 1.650 [19.6 x 41.9]	65.0	43.0	3.62	45.0
3900.0	U673D398F016GL1C	0.770 x 2.150 [19.6 x 54.6]	44.0	30.0	4.84	32.0
5600.0	U673D568F016GP1C	0.770 x 2.650 [19.6 x 67.3]	34.0	23.5	6.01	26.0
6800.0	U673D688F016GS1C	0.770 x 3.150 [19.6 x 80.0]	28.0	19.7	7.09	23.0
8200.0	U673D828F016GT1C	0.770 x 3.650 [19.6 x 92.7]	24.0	17.0	8.16	21.0
2200.0	U673D228F016HE1C	0.895 x 1.150 [22.7 x 29.2]	89.0	59.0	2.93	61.0
3900.0	U673D398F016HJ1C	0.895 x 1.650 [22.7 x 41.9]	45.0	31.6	4.64	34.0
5600.0	U673D568F016HL1C	0.895 x 2.150 [22.7 x 54.6]	31.6	22.4	6.14	25.0



STANDARD RATINGS in inches [millimeters]						
CAPACITANCE E (μ F)	PART NUMBER	NOMINAL CASE SIZE D x L	Max. ESR at + 25 °C (m Ω)		Max. RIPPLE at + 105 °C (A) 20 kHz - 40 kHz	Max. Z at 100 kHz (m Ω)
			120 Hz	20 kHz - 40 kHz		
16 WVDC at 105 °C, SURGE = 20 V						
8200.0	U673D828F016HP1C	0.895 x 2.650 [22.7 x 67.3]	24.7	17.9	7.51	20.0
10000.0	U673D109F016HS1C	0.895 x 3.150 [22.7 x 80.0]	20.7	15.2	8.79	18.0
12000.0	U673D129F016HT1C	0.895 x 3.650 [22.7 x 92.7]	18.0	13.6	9.93	17.0
2700.0	U673D278F016JE1C	1.020 x 1.150 [25.9 x 29.2]	71.0	50.0	3.49	52.0
5600.0	U673D568F016JJ1C	1.020 x 1.650 [25.9 x 41.9]	36.7	26.7	5.48	29.0
8200.0	U673D828F016JL1C	1.020 x 2.150 [25.9 x 54.6]	26.0	19.2	7.18	22.0
12000.0	U673D129F016JP1C	1.020 x 2.650 [25.9 x 67.3]	20.5	15.4	8.75	19.0
15000.0	U673D159F016JS1C	1.020 x 3.150 [25.9 x 80.0]	17.4	13.3	10.20	17.0
18000.0	U673D189F016JT1C	1.020 x 3.650 [25.9 x 92.7]	15.3	11.8	11.50	17.0
20 WVDC at + 105 °C, SURGE = 30 V						
1000.0	U673D108F020GE1C	0.770 x 1.150 [19.6 x 29.2]	140.0	84.0	2.16	87.0
1800.0	U673D188F020GJ1C	0.770 x 1.650 [19.6 x 41.9]	67.0	44.0	3.56	47.0
2700.0	U673D278F020GL1C	0.770 x 2.150 [19.6 x 54.6]	45.0	30.0	4.81	33.0
3900.0	U673D398F020GP1C	0.770 x 2.650 [19.6 x 67.3]	34.9	23.9	6.96	27.0
4700.0	U673D478F020GS1C	0.770 x 3.150 [19.6 x 80.0]	28.7	19.9	7.05	24.0
5600.0	U673D568F020GT1C	0.770 x 3.650 [19.6 x 92.7]	24.6	17.0	8.09	21.0
1500.0	U673D158F020HE1C	0.895 x 1.150 [22.7 x 29.2]	94.0	59.0	2.86	62.0
3300.0	U673D338F020HJ1C	0.895 x 1.650 [22.7 x 41.9]	46.9	32.0	4.60	35.0
4700.0	U673D478F020HL1C	0.895 x 2.150 [22.7 x 54.6]	32.0	22.7	6.10	26.0
6800.0	U673D688F020HP1C	0.895 x 2.650 [22.7 x 67.3]	25.0	18.0	7.49	21.0
8200.0	U673D828F020HS1C	0.895 x 3.150 [22.7 x 80.0]	21.0	15.3	8.77	19.0
10000.0	U673D109F020HT1C	0.895 x 3.650 [22.7 x 92.7]	18.0	13.6	9.93	18.0
2200.0	U673D228F020JE1C	1.020 x 1.150 [25.9 x 29.2]	72.0	49.0	3.48	52.0
4700.0	U673D478F020JJ1C	1.020 x 1.650 [25.9 x 41.9]	37.0	26.0	5.47	29.0
6800.0	U673D688F020JL1C	1.020 x 2.150 [25.9 x 54.6]	26.0	19.3	7.16	23.0
8200.0	U673D828F020JP1C	1.020 x 2.650 [25.9 x 67.3]	20.7	15.5	8.72	19.0
10000.0	U673D109F020JS1C	1.020 x 3.150 [25.9 x 80.0]	17.9	13.6	10.10	18.0
12000.0	U673D129F020JT1C	1.020 x 3.650 [25.9 x 92.7]	15.8	12.0	11.40	16.0
25 WVDC at + 105 °C, SURGE = 35 V						
820.0	U673D827F025GE1C	0.770 x 1.150 [19.6 x 29.2]	143.0	85.0	2.23	88.0
1500.0	U673D158F025GJ1C	0.770 x 1.650 [19.6 x 41.9]	73.0	44.0	3.56	47.0
2200.0	U673D228F025GL1C	0.770 x 2.150 [19.6 x 54.6]	49.0	30.5	4.82	33.0
3300.0	U673D338F025GP1C	0.770 x 2.650 [19.6 x 67.3]	37.0	23.9	5.96	27.0
3900.0	U673D398F025GS1C	0.770 x 3.150 [19.6 x 80.0]	31.0	20.0	7.00	23.0
4700.0	U673D478F025GT1C	0.770 x 3.650 [19.6 x 92.7]	26.7	17.5	8.04	21.0
1200.0	U673D128F025HE1C	0.895 x 1.150 [22.7 x 29.2]	101.0	62.9	2.86	66.0
2700.0	U673D278F025HJ1C	0.895 x 1.650 [22.7 x 41.9]	50.0	32.0	4.61	35.0
3900.0	U673D398F025HL1C	0.895 x 2.150 [22.7 x 54.6]	35.0	22.9	6.08	26.0
4700.0	U673D478F025HP1C	0.895 x 2.650 [22.7 x 67.3]	27.0	18.0	7.47	21.0
6800.0	U673D688F025HS1C	0.895 x 3.150 [22.7 x 80.0]	22.7	15.4	8.74	19.0
8200.0	U673D828F025HT1C	0.895 x 3.650 [22.7 x 92.7]	19.6	13.6	9.93	17.0
1800.0	U673D188F025JE1C	1.020 x 1.150 [25.9 x 29.2]	79.0	51.0	3.45	53.0
3900.0	U673D398F025JJ1C	1.020 x 1.650 [25.9 x 41.9]	40.0	26.9	5.46	30.0
5600.0	U673D568F025JL1C	1.020 x 2.150 [25.9 x 54.6]	28.0	19.0	7.14	22.0
6800.0	U673D688F025JP1C	1.020 x 2.650 [25.9 x 67.3]	22.0	15.7	8.66	19.0
8200.0	U673D828F025JS1C	1.020 x 3.150 [25.9 x 80.0]	18.7	13.5	10.10	17.0
10000.0	U673D109F025JT1C	1.020 x 3.650 [25.9 x 92.7]	16.4	12.0	11.40	15.0

U673D and U674D

Vishay Sprague

Aluminum Capacitors
+ 105 °C, Tubular Radial Lead



STANDARD RATINGS in inches [millimeters]						
CAPACITANCE E (μ F)	PART NUMBER	NOMINAL CASE SIZE D x L	Max. ESR at + 25 °C ($m\Omega$)		Max. RIPPLE at + 105 °C (A) 20 kHz - 40 kHz	Max. Z at 100 kHz ($m\Omega$)
			120 Hz	20 kHz - 40 kHz		
30 WVDC at + 105 °C, SURGE = 40 V						
820.0	U673D827F030GE1C	0.770 x 1.150 [19.6 x 29.2]	156.0	86.0	2.16	89.0
1500.0	U673D158F030GJ1C	0.770 x 1.650 [19.6 x 41.9]	80.0	47.0	3.45	50.0
2200.0	U673D228F030GL1C	0.770 x 2.150 [19.6 x 54.6]	53.0	32.0	4.68	35.0
3300.0	U673D338F030GP1C	0.770 x 2.650 [19.6 x 67.3]	40.0	25.0	5.81	28.0
3900.0	U673D398F030GS1C	0.770 x 3.150 [19.6 x 80.0]	34.0	21.0	6.82	24.0
4700.0	U673D478F030GT1C	0.770 x 3.650 [19.2 x 92.7]	28.8	18.4	7.84	22.0
1200.0	U673D128F030HE1C	0.895 x 1.150 [22.7 x 29.2]	106.0	64.0	2.83	67.0
2700.0	U673D278F030HJ1C	0.895 x 1.650 [22.7 x 41.9]	54.0	33.4	4.51	37.0
3900.0	U673D398F030HL1C	0.895 x 2.150 [22.7 x 54.6]	37.0	23.7	5.97	27.0
4700.0	U673D478F030HP1C	0.895 x 2.650 [22.7 x 67.3]	29.0	18.9	7.31	22.0
6800.0	U673D688F030HS1C	0.895 x 3.150 [22.7 x 80.0]	24.0	16.0	8.57	19.0
8200.0	U673D828F030HT1C	0.895 x 3.650 [22.7 x 92.7]	20.8	14.0	9.75	17.0
1800.0	U673D188F030JE1C	1.020 x 1.150 [25.9 x 29.2]	85.0	53.0	3.39	56.0
3300.0	U673D338F030JJ1C	1.020 x 1.650 [25.9 x 41.9]	43.7	28.0	5.33	31.0
4700.0	U673D478F030JL1C	1.020 x 2.150 [25.9 x 54.6]	30.0	20.0	7.04	23.0
6800.0	U673D688F030JP1C	1.020 x 2.650 [25.9 x 67.3]	23.7	16.2	8.53	20.0
8200.0	U673D828F030JS1C	1.020 x 3.150 [25.9 x 80.0]	19.8	13.8	9.95	17.0
10000.0	U673D109F030JT1C	1.020 x 3.650 [25.9 x 92.7]	17.3	12.2	11.30	15.0
40 WVDC at + 105 °C, SURGE = 55 V						
560.0	U673D567F040GE1C	0.770 x 1.150 [19.6 x 29.2]	191.0	86.0	2.22	89.0
1000.0	U673D108F040GJ1C	0.770 x 1.650 [19.6 x 41.9]	94.0	47.0	3.57	67.0
1500.0	U673D158F040GL1C	0.770 x 2.150 [19.6 x 54.6]	64.0	32.0	4.80	30.0
1800.0	U673D188F040GP1C	0.770 x 2.650 [19.6 x 67.3]	49.0	25.0	5.92	27.0
2200.0	U673D228F040GS1C	0.770 x 3.150 [19.6 x 80.0]	40.0	21.0	7.00	30.0
2700.0	U673D278F040GT1C	0.770 x 3.650 [19.6 x 92.7]	34.8	18.6	8.02	21.0
680.0	U673D687F040HE1C	0.895 x 1.150 [22.7 x 29.2]	130.0	64.0	3.00	62.0
1500.0	U673D158F040HJ1C	0.895 x 1.650 [22.7 x 41.9]	67.0	33.0	4.54	36.0
2200.0	U673D228F040HL1C	0.895 x 2.150 [22.7 x 54.6]	45.0	23.0	6.05	26.0
3300.0	U673D338F040HP1C	0.895 x 2.650 [22.7 x 67.3]	34.0	18.4	7.41	22.0
3900.0	U673D398F040HS1C	0.895 x 3.150 [22.7 x 80.0]	29.0	16.8	8.63	19.0
4700.0	U673D478F040HT1C	0.895 x 3.650 [22.7 x 92.7]	25.8	14.8	9.85	17.0
1000.0	U673D108F040JE1C	1.020 x 1.150 [25.9 x 29.2]	105.0	53.0	3.41	55.0
2200.0	U673D228F040JJ1C	1.020 x 1.650 [25.9 x 41.9]	51.7	28.0	5.42	30.0
2700.0	U673D278F040JL1C	1.020 x 2.150 [25.9 x 54.6]	36.0	20.0	7.49	23.0
3900.0	U673D398F040JP1C	1.020 x 2.650 [25.9 x 67.3]	28.7	16.0	8.90	19.0
4700.0	U673D478F040JS1C	1.020 x 3.150 [25.9 x 80.0]	23.8	13.0	10.60	17.0
5600.0	U673D568F040JT1C	1.020 x 3.650 [25.9 x 92.7]	20.3	12.0	11.40	16.0
50 WVDC at + 105 °C, SURGE = 75 V						
390.0	U673D397F050GE1C	0.770 x 1.150 [19.6 x 29.2]	212.0	86.0	2.21	89.0
820.0	U673D827F050GJ1C	0.770 x 1.650 [19.6 x 41.9]	50.0	44.0	3.57	47.0
1200.0	U673D128F050GL1C	0.770 x 2.150 [19.6 x 54.6]	74.0	32.0	4.70	35.0
1500.0	U673D158F050GP1C	0.770 x 2.650 [19.6 x 67.3]	56.0	25.0	5.83	28.0
1800.0	U673D188F050GS1C	0.770 x 3.150 [19.6 x 80.0]	44.0	20.0	7.00	23.0
2200.0	U673D228F050GT1C	0.770 x 3.650 [19.6 x 92.7]	37.7	17.7	8.00	21.0
560.0	U673D567F050HE1C	0.895 x 1.150 [22.7 x 29.2]	145.0	59.0	2.87	62.0
1200.0*	U673D128F050HJ1C	0.895 x 1.650 [22.7 x 41.9]	76.0	34.0	4.46	37.0
1800.0	U673D188F050HL1C	0.895 x 2.150 [22.7 x 54.6]	50.0	23.3	6.02	26.0

* These values are normally stocked.



STANDARD RATINGS in inches [millimeters]						
CAPACITANCE E (µF)	PART NUMBER	NOMINAL CASE SIZE D x L	Max. ESR at + 25 °C (mΩ)		Max. RIPPLE at + 105 °C (A) 20 kHz - 40 kHz	Max. Z at 100 kHz (mΩ)
			120 Hz	20 kHz - 40 kHz		
50 WVDC at + 105 °C, SURGE = 75 V						
2200.0	U673D228F050HP1C	0.895 x 2.650 [22.7 x 67.3]	39.0	18.7	7.35	22.0
2700.0	U673D278F050HS1C	0.895 x 3.150 [22.7 x 80.0]	31.4	15.7	8.65	19.0
3300.0	U673D338F050HT1C	0.895 x 3.650 [22.7 x 92.7]	27.0	13.9	9.82	17.0
820.0	U673D828F050JE1C	1.020 x 1.150 [25.9 x 29.2]	112.0	51.4	3.45	54.0
1500.0	U673D158F050JJ1C	1.020 x 1.650 [25.9 x 41.9]	58.0	27.8	5.37	31.0
2200.0	U673D228F050JL1C	1.020 x 2.150 [25.9 x 54.6]	39.0	19.7	7.09	23.0
3300.0	U673D338F050JP1C	1.020 x 2.650 [25.9 x 67.3]	30.0	15.9	8.61	20.0
3900.0	U673D398F050JS1C	1.020 x 3.150 [25.9 x 80.0]	25.0	13.6	10.10	18.0
4700.0	U673D478F050JT1C	1.020 x 3.650 [25.9 x 92.7]	21.6	12.0	11.40	16.0
63 WVDC at + 105 °C, SURGE = 85 V						
330.0	U673D337F063GE1C	0.770 x 1.150 [19.6 x 29.2]	236.0	89.0	2.13	93.0
680.0	U673D687F063GJ1C	0.770 x 1.650 [19.6 x 41.9]	117.0	47.0	3.44	50.0
1000.0	U673D108F063GL1C	0.770 x 2.150 [19.6 x 54.6]	79.0	33.3	4.61	36.0
1200.0	U673D128F063GP1C	0.770 x 2.650 [19.6 x 67.3]	63.0	27.0	5.61	30.0
1800.0	U673D188F063GS1C	0.770 x 3.150 [19.6 x 80.0]	49.9	22.0	6.71	25.0
2200.0	U673D228F063GT1C	0.770 x 3.650 [19.6 x 92.7]	41.7	18.9	7.74	22.0
560.0	U673D567F063HE1C	0.895 x 1.150 [22.7 x 29.2]	159.0	66.0	2.79	69.0
1000.0	U673D108F063HJ1C	0.895 x 1.650 [22.7 x 41.9]	82.0	35.4	4.38	38.0
1500.0	U673D158F063HL1C	0.895 x 2.150 [22.7 x 54.6]	54.0	24.5	5.87	28.0
2200.0	U673D228F063HP1C	0.895 x 2.650 [22.7 x 67.3]	41.0	19.3	7.24	22.0
2700.0	U673D278F063HS1C	0.895 x 3.150 [22.7 x 80.0]	34.6	16.6	8.42	20.0
3300.0	U673D338F063HT1C	0.895 x 3.650 [22.7 x 92.7]	29.0	14.5	9.61	18.0
680.0	U673D687F063JE1C	1.020 x 1.150 [25.9 x 29.2]	122.0	51.0	3.70	54.0
1500.0	U673D158F063JJ1C	1.020 x 1.650 [25.9 x 41.9]	63.0	28.0	5.54	31.0
2200.0	U673D228F063JL1C	1.020 x 2.150 [25.9 x 54.6]	42.0	20.6	6.93	24.0
2700.0	U673D278F063JP1C	1.020 x 2.650 [25.9 x 67.3]	32.9	16.5	8.45	20.0
3900.0	U673D398F063JS1C	1.020 x 3.150 [25.9 x 80.0]	27.0	14.0	9.85	18.0
4700.0*	U673D478F063JT1C	1.020 x 3.650 [25.9 x 92.7]	23.3	12.4	11.20	16.0
75 WVDC at + 105 °C, SURGE = 100 V						
270.0	U673D277F075GE1C	0.770 x 1.150 [19.6 x 29.2]	311.0	141.0	1.73	145.0
560.0	U673D567F075GJ1C	0.770 x 1.650 [19.6 x 41.9]	150.0	70.0	2.84	73.0
820.0	U673D827F075GL1C	0.770 x 2.150 [19.6 x 54.6]	101.0	48.0	3.84	51.0
1200.0	U673D128F075GP1C	0.770 x 2.650 [19.6 x 67.3]	77.0	37.3	4.77	40.0
1500.0	U673D158F075GS1C	0.770 x 3.150 [19.6 x 80.0]	63.0	30.7	5.68	34.0
1800.0	U673D188F075GT1C	0.770 x 3.650 [19.6 x 92.7]	53.0	26.4	6.55	30.0
390.0	U673D397F075HE1C	0.895 x 1.150 [22.7 x 29.2]	214.0	100.0	2.27	104.0
820.0	U673D827F075HJ1C	0.895 x 1.650 [22.7 x 41.9]	104.0	50.0	3.67	53.0
1200.0	U673D128F075HL1C	0.895 x 2.150 [22.7 x 54.6]	73.0	36.0	4.83	39.0
1800.0	U673D188F075HP1C	0.895 x 2.650 [22.7 x 67.3]	54.0	27.5	6.06	31.0
2200.0	U673D228F075HS1C	0.895 x 3.150 [22.7 x 80.0]	45.0	23.0	7.12	26.0
2700.0	U673D278F075HT1C	0.895 x 3.650 [22.7 x 92.7]	37.0	19.8	8.23	23.0
560.0	U673D567F075JE1C	1.020 x 1.150 [25.9 x 29.2]	159.0	78.0	2.81	81.0
1200.0	U673D128F075JJ1C	1.020 x 1.650 [25.9 x 41.9]	82.0	41.4	4.40	44.0
1800.0	U673D188F075JL1C	1.020 x 2.150 [25.9 x 54.6]	53.9	28.0	5.95	30.0
2200.0	U673D228F075JP1C	1.020 x 2.650 [25.9 x 67.3]	41.8	22.2	7.29	25.0
2700.0	U673D278F075JS1C	1.020 x 3.150 [25.9 x 80.0]	33.7	18.5	8.60	22.0
3300.0	U673D338F075JT1C	1.020 x 3.650 [25.9 x 92.7]	29.0	16.2	9.80	19.0

* These values are normally stocked.

U673D and U674D

Vishay Sprague

Aluminum Capacitors
+ 105 °C, Tubular Radial Lead



STANDARD RATINGS in inches [millimeters]						
CAPACITANCE E (μ F)	PART NUMBER	NOMINAL CASE SIZE D x L	Max. ESR at + 25 °C ($m\Omega$)		Max. RIPPLE at + 105 °C (A) 20 kHz - 40 kHz	Max. Z at 100 kHz ($m\Omega$)
			120 Hz	20 kHz - 40 kHz		
100 WVDC at + 105 °C, SURGE = 125 V						
150.0	U673D157F100GE1C	0.770 x 1.150 [19.6 x 29.2]	698.0	324.0	1.14	326.0
270.0	U673D277F100GJ1C	0.770 x 1.650 [19.6 x 41.9]	329.0	154.0	1.92	156.0
390.0	U673D397F100GL1C	0.770 x 2.150 [19.6 x 54.6]	221.0	104.0	2.60	106.0
560.0	U673D567F100GP1C	0.770 x 2.650 [19.6 x 67.3]	164.0	78.0	3.39	80.0
680.0	U673D687F100GS1C	0.770 x 3.150 [19.6 x 80.0]	131.0	63.0	3.96	65.0
820.0	U673D827F100GT1C	0.770 x 3.650 [19.6 x 92.7]	110.0	53.0	4.60	54.0
220.0	U673D227F100HE1C	0.895 x 1.150 [22.7 x 29.2]	452.0	212.0	1.55	215.0
390.0	U673D397F100HJ1C	0.895 x 1.650 [22.7 x 41.9]	216.0	103.0	2.57	106.0
680.0	U673D687F100HL1C	0.895 x 2.150 [22.7 x 54.6]	143.0	69.0	3.49	71.0
820.0	U673D827F100HP1C	0.895 x 2.650 [22.7 x 67.3]	107.0	52.0	13606	53.0
1000.0	U673D108F100HS1C	0.895 x 3.150 [22.7 x 80.0]	89.0	44.0	42125	45.0
1200.0	U673D128F100HT1C	0.895 x 3.650 [22.7 x 92.7]	76.0	38.0	34090	39.0
270.0	U673D277F100JE1C	1.020 x 1.150 [25.9 x 29.2]	337.0	162.0	34700	163.0
560.0	U673D567F100JJ1C	1.020 x 1.650 [25.9 x 41.9]	163.0	79.0	3.17	81.0
820.0	U673D827F100JL1C	1.020 x 2.150 [25.9 x 54.6]	109.0	54.0	4.27	55.0
1200.0	U673D128F100JP1C	1.020 x 2.650 [25.9 x 67.3]	83.0	42.0	5.28	43.0
1500.0	U673D158F100JS1C	1.020 x 3.150 [25.9 x 80.0]	67.0	34.0	6.29	35.0
1800.0	U673D188F100JT1C	1.020 x 3.650 [25.9 x 92.7]	57.0	29.5	7.26	31.0
150 WVDC at + 105 °C, SURGE = 200 V						
56.0	U673D566F150GE1C	0.770 x 1.150 [19.6 x 29.2]	1733.0	881.0	0.694	895.0
100.0	U673D107F150GJ1C	0.770 x 1.650 [19.6 x 41.9]	886.0	450.0	1.12	460.0
180.0	U673D187F150GL1C	0.770 x 2.150 [19.6 x 54.6]	569.0	290.0	1.56	297.0
220.0	U673D227F150GP1C	0.770 x 2.650 [19.6 x 67.3]	419.0	215.0	1.99	220.0
330.0	U673D337F150GS1C	0.770 x 3.150 [19.6 x 80.0]	333.0	170.0	2.41	175.0
390.0	U673D397F150GT1C	0.770 x 3.650 [19.6 x 92.7]	276.0	141.0	2.83	148.0
82.0	U673D826F150HE1C	0.895 x 1.150 [22.7 x 29.2]	1152.0	588.0	0.936	592.0
180.0	U673D187F150HL1C	0.895 x 1.650 [22.7 x 41.9]	579.0	296.0	1.51	300.0
270.0	U673D277F150HL1C	0.895 x 2.150 [22.7 x 54.6]	376.0	193.0	2.09	198.0
390.0	U673D397F150HP1C	0.895 x 2.650 [22.7 x 67.3]	279.0	143.0	2.66	148.0
470.0	U673D477F150HT1C	0.895 x 3.150 [22.7 x 80.0]	222.0	115.0	3.19	120.0
560.0	U673D567F150HT1C	0.895 x 3.650 [22.7 x 92.7]	185.0	96.0	3.74	100.0

ORIGINAL RATINGS						
CAPACITANCE (μ F)	PART NUMBER*	CASE CODE	Max. ESR at + 25 °C ($m\Omega$)		Max. RIPPLE at + 105 °C (A) 20 kHz - 100 kHz	Max. IMPEDANCE at 100 kHz ($m\Omega$)
			120 Hz	20 kHz		
6.3 WVDC at 105 °C, SURGE = 9 V						
1500.0	U673D158H6R3GE5C	GE	98.0	69.0	2.48	70.0
2200.0	U673D228H6R3HE5C	HE	71.0	51.0	3.18	52.0
2700.0	U673D278H6R3JE5C	JE	62.0	47.0	3.60	49.0
3900.0	U673D398H6R3HJ5C	HJ	41.0	30.0	4.76	31.0
5600.0	U673D568H6R3JJ5C	JJ	33.0	25.0	5.66	27.0
6800.0	U673D688H6R3GS5C	GS	23.0	18.0	7.40	19.0
8200.0	U673D828H6R3JL5C	JL	23.0	18.0	7.41	20.0
10000.0	U673D109H6R3HS5C	HS	19.0	15.0	8.85	17.0
12000.0	U673D129H6R3JP5C	JP	19.0	15.0	8.86	17.0
15000.0	U673D159H6R3JS5C	JS	15.0	13.0	10.20	14.0
18000.0	U673D189H6R3JT5C	JT	14.0	12.0	11.40	13.0

* For applications requiring single ended, 3 lead capacitors, change the Part Number U673D to Part Number U674D. Type U674D is only available in terminal style 'A'.



ORIGINAL RATINGS						
CAPACITANCE (μ F)	PART NUMBER*	CASE CODE	Max. ESR at + 25 °C ($m\Omega$)		Max. RIPPLE at + 105 °C (A) 20 kHz - 100 kHz	Max. IMPEDANCE at 100 kHz ($m\Omega$)
			120 Hz	20 kHz		
7.5 WVDC at + 105 °C, SURGE = 10 V						
1200.0	U673D128H7R5GE5C	GE	115.0	76.0	2.36	78.0
1800.0	U673D188H7R5HE5C	HE	80.0	55.0	3.06	56.0
2700.0	U673D278H7R5JE5C	JE	62.0	45.0	3.68	46.0
3900.0	U673D398H7R5HJ5C	HJ	39.0	28.0	4.92	29.0
4700.0	U673D478H7R5JJ5C	JJ	35.0	25.0	5.66	26.0
5600.0	U673D568H7R5HL5C	HL	28.0	20.0	6.50	22.0
6800.0	U673D688H7R5HP5C	HP	23.0	17.0	7.70	19.0
8200.0	U673D828H7R5JL5C	JL	23.0	18.0	7.41	19.0
10000.0	U673D109H7R5JP5C	JP	19.0	15.0	8.86	16.0
12000.0	U673D129H7R5JS5C	JS	17.0	13.0	10.20	14.0
15000.0	U673D159H7R5JT5C	JT	14.0	12.0	11.40	13.0
10 WVDC at + 105 °C, SURGE = 14 V						
1000.0	U673D108H010GE5C	GE	123.0	76.0	2.36	77.0
1500.0	U673D158H010HE5C	HE	89.0	56.0	3.03	58.0
2200.0	U673D228H010JE5C	JE	67.0	45.0	3.68	47.0
3300.0	U673D338H010HJ5C	HJ	43.0	29.0	4.84	30.0
3900.0	U673D398H010GP5C	GP	31.0	20.0	6.51	23.0
4700.0	U673D478H010JJ5C	JJ	35.0	24.0	5.78	26.0
5600.0	U673D568H010HP5C	HP	22.0	15.0	8.20	18.0
6800.0	U673D688H010JL5C	JL	23.0	16.0	7.86	19.0
8200.0	U673D828H010JP5C	JP	19.0	14.0	9.17	17.0
10000.0	U673D109H010JS5C	JS	16.0	12.0	10.60	15.0
12000.0	U673D129H010JT5C	JT	14.0	11.0	11.90	14.0
12 WVDC at + 105 °C, SURGE = 16 V						
1000.0	U673D108H012GE5C	GE	126.0	76.0	2.36	79.0
1500.0**	U673D158H012HE5C	HE	88.0	55.0	3.06	58.0
2200.0	U673D228H012JE5C	JE	68.0	43.0	3.77	45.0
2700.0	U673D278H012GL5C	GL	41.0	25.0	5.31	27.0
3300.0	U673D338H012HJ5C	HJ	45.0	29.0	4.84	31.0
3900.0	U673D398H012JJ5C	JJ	38.0	25.0	5.66	28.0
4700.0	U673D478H012HL5C	HL	30.0	19.0	6.67	21.0
5600.0	U673D568H012JL5C	JL	24.0	17.0	7.62	21.0
6800.0	U673D688H012HS5C	HS	19.0	13.0	9.51	17.0
8200.0	U673D828H012JP5C	JP	19.0	14.0	9.17	18.0
10000.0	U673D109H012JS5C	JS	16.0	12.0	10.60	16.0
12000.0	U673D129H012JT5C	JT	14.0	10.0	12.40	14.0
15 WVDC at + 105 °C, SURGE = 20 V						
820.0	U673D827H015GE5C	GE	142.0	78.0	2.33	80.0
1500.0	U673D158H015HE5C	HE	86.0	51.0	3.18	53.0
1800.0	U673D188H015JE5C	JE	74.0	46.0	3.64	48.0
2700.0	U673D278H015HJ5C	HJ	47.0	28.0	4.92	30.0
3300.0	U673D338H015GP5C	GP	34.0	20.0	6.51	23.0
3900.0	U673D398H015JJ5C	JJ	37.0	24.0	5.78	27.0
5600.0	U673D568H015JL5C	JL	25.0	17.0	7.62	20.0
6800.0	U673D688H015JP5C	JP	20.0	13.0	9.51	17.0
8200.0	U673D828H015JS5C	JS	17.0	12.0	10.60	16.0
12000.0	U673D129H015JT5C	JT	15.0	10.0	12.40	14.0

* For applications requiring single ended, 3 lead capacitors, change the Part Number U673D to Part Number U674D. Type U674D is only available in terminal style 'A'.

** These values are normally stocked.

U673D and U674D

Vishay Sprague

Aluminum Capacitors
+ 105 °C, Tubular Radial Lead



ORIGINAL RATINGS						
CAPACITANCE (μ F)	PART NUMBER*	CASE CODE	Max. ESR at + 25 °C ($m\Omega$)		Max. RIPPLE at + 105 °C (A) 20 kHz - 100 kHz	Max. IMPEDANCE at 100 kHz ($m\Omega$)
			120 Hz	20 kHz		
20 WVDC at + 105 °C, SURGE = 30 V						
680.0	U673D687H020GE5C	GE	131.0	72.0	2.42	75.0
1000.0	U673D108H020HE5C	HE	86.0	50.0	3.21	54.0
1500.0	U673D158H020JE5C	JE	71.0	43.0	3.68	45.0
2200.0**	U673D228H020HJ5C	HJ	44.0	26.0	5.11	28.0
2700.0	U673D278H020JJ5C	JJ	37.0	23.0	5.90	25.0
3300.0	U673D338H020HL5C	HL	30.0	19.0	6.67	21.0
3900.0	U673D398H020GT5C	GT	24.0	15.0	8.69	18.0
4700.0	U673D478H020JL5C	JL	26.0	17.0	7.62	20.0
5600.0	U673D568H020JP5C	JP	20.0	14.0	9.17	17.0
6800.0	U673D688H020JS5C	JS	17.0	12.0	10.60	16.0
8200.0	U673D828H020JT5C	JT	15.0	10.0	12.40	14.0
25 WVDC at + 105 °C, SURGE = 35 V						
560.0**	U673D567H025GE5C	GE	144.0	67.0	2.51	70.0
820.0	U673D827H025HE5C	HE	103.0	51.0	3.18	55.0
1200.0	U673D128H025JE5C	JE	80.0	42.0	3.81	44.0
1500.0	U673D158H025GL5C	GL	49.0	24.0	5.42	26.0
1800.0	U673D188H025HJ5C	HJ	52.0	27.0	5.01	30.0
2200.0	U673D228H025JJ5C	JJ	41.0	23.0	5.90	25.0
2700.0	U673D278H025GS5C	GS	31.0	16.0	7.85	19.0
3300.0	U673D338H025JL5C	JL	28.0	16.0	7.86	19.0
3900.0	U673D398H025HS5C	HS	23.0	13.0	18872	16.0
4700.0	U673D478H025JP5C	JP	22.0	13.0	18872	16.0
5600.0	U673D568H025JS5C	JS	19.0	11.0	38271	14.0
6800.0	U673D688H025JT5C	JT	16.0	10.0	14946	13.0
40 WVDC at + 105 °C, SURGE = 55 V						
330.0**	U673D337H040GE5C	GE	199.0	69.0	17564	71.0
560.0**	U673D567H040HE5C	HE	135.0	50.0	44256	54.0
680.0**	U673D687H040JE5C	JE	110.0	44.0	26359	47.0
1000.0**	U673D108H040HJ5C	HJ	67.0	27.0	37991	30.0
1200.0	U673D128H040GP5C	GP	51.0	20.0	18780	22.0
1500.0**	U673D158H040JJ5C	JJ	55.0	23.0	32994	26.0
1800.0	U673D188H040GS5C	GS	41.0	16.0	31229	19.0
2200.0	U673D228H040JL5C	JL	38.0	17.0	22828	19.0
2700.0	U673D278H040JP5C	JP	29.0	14.0	42979	17.0
3300.0	U673D338H040JS5C	JS	24.0	12.0	22190	15.0
3900.0	U673D398H040JT5C	JT	21.0	10.0	14946	13.0
50 WVDC at + 105 °C, SURGE = 75 V						
270.0	U673D277H050GE5C	GE	249.0	70.0	16834	72.0
390.0**	U673D397H050HE5C	HE	170.0	52.0	42064	54.0
470.0	U673D477H050GJ5C	GJ	122.0	36.0	35125	38.0
560.0	U673D567H050JE5C	JE	129.0	43.0	28185	45.0
820.0**	U673D827H050HJ5C	HJ	85.0	27.0	37991	30.0
1000.0	U673D108H050JJ5C	JJ	65.0	23.0	32994	25.0
1200.0	U673D128H050HL5C	HL	57.0	19.0	24624	21.0
1500.0	U673D158H050JL5C	JL	44.0	17.0	22828	20.0
1800.0	U673D188H050HS5C	HS	36.0	13.0	18872	16.0
2200.0	U673D228H050JP5C	JP	34.0	14.0	42979	17.0
2700.0	U673D278H050JS5C	JS	28.0	12.0	22190	15.0
3300.0	U673D338H050JT5C	JT	24.0	10.0	14946	13.0

* For applications requiring single ended, 3 lead capacitors, change the Part Number U673D to Part Number U674D. Type U674D is only available in terminal style 'A'.

** These values are normally stocked.



ORIGINAL RATINGS						
CAPACITANCE (μ F)	PART NUMBER*	CASE CODE	Max. ESR at + 25 °C ($m\Omega$)		Max. RIPPLE at + 105 °C (A) 20 kHz - 100 kHz	Max. IMPEDANCE at 100 kHz ($m\Omega$)
			120 Hz	20 kHz		
60 WVDC at + 105 °C, SURGE = 85 V						
180.0	U673D187H060GE5C	GE	341.0	73.0	15008	75.0
270.0**	U673D277H060HE5C	HE	215.0	51.0	43160	54.0
330.0**	U673D337H060GJ5C	GJ	167.0	38.0	31107	40.0
390.0	U673D397H060JE5C	JE	164.0	43.0	28185	45.0
560.0	U673D567H060HJ5C	HJ	106.0	27.0	37991	29.0
680.0	U673D687H060GP5C	GP	84.0	21.0	12936	23.0
820.0	U673D827H060JJ5C	JJ	82.0	23.0	32994	26.0
1000.0	U673D108H060GT5C	GT	57.0	15.0	25416	18.0
1200.0**	U673D128H060JL5C	JL	55.0	17.0	22828	20.0
1500.0	U673D158H060JP5C	JP	42.0	13.0	18872	17.0
1800.0	U673D188H060JS5C	JS	35.0	12.0	22190	16.0
2200.0	U673D228H060JT5C	JT	30.0	10.0	14946	14.0
75 WVDC at + 105 °C, SURGE = 100 V						
120.0	U673D127H075GE5C	GE	600.0	169.0	21186	170.0
180.0	U673D187H075HE5C	HE	399.0	116.0	38262	117.0
220.0**	U673D227H075JE5C	JE	300.0	92.0	20852	93.0
330.0	U673D337H075HJ5C	HJ	196.0	59.0	14305	60.0
470.0	U673D477H075JJ5C	JJ	145.0	46.0	42826	47.0
560.0**	U673D567H075HL5C	HL	131.0	40.0	21641	41.0
680.0**	U673D687H075JL5C	JL	98.0	32.0	38021	31.0
820.0	U673D827H075HS5C	HS	80.0	26.0	26451	28.0
1000.0**	U673D108H075JP5C	JP	73.0	24.0	7.00	26.0
1200.0	U673D128H075JS5C	JS	59.0	20.0	46600	22.0
1500.0	U673D158H075JT5C	JT	50.0	18.0	11202	20.0
100 WVDC at + 105 °C, SURGE = 125 V						
68.0**	U673D686H100GE5C	GE	992.0	292.0	43831	295.0
120.0**	U673D127H100HE5C	HE	602.0	182.0	24838	185.0
150.0**	U673D157H100JE5C	JE	490.0	150.0	37988	155.0
220.0	U673D227H100HJ5C	HJ	294.0	90.0	27061	91.0
270.0	U673D277H100GP5C	GP	240.0	73.0	14671	74.0
330.0**	U673D337H100JJ5C	JJ	239.0	75.0	46447	76.0
390.0	U673D397H100GT5C	GT	161.0	50.0	27851	51.0
470.0	U673D477H100JL5C	JL	159.0	51.0	14702	52.0
560.0	U673D567H100JP5C	JP	120.0	39.0	18019	40.0
680.0	U673D687H100JS5C	JS	96.0	32.0	19511	33.0
820.0	U673D827H100JT5C	JT	81.0	28.0	16984	29.0
150 WVDC at + 105 °C, SURGE = 200 V						
56.0**	U673D566H150GE5C	GE	1733.0	881.0	.694	895.0
82.0	U673D826H150HE5C	HE	1152.0	588.0	.936	592.0
100.0	U673D107H150GJ5C	GJ	886.0	450.0	38322	460.0
150.0	U673D157H150GL5C	GL	569.0	290.0	20455	297.0
220.0	U673D227H150HL5C	HL	376.0	193.0	38232	198.0
330.0	U673D337H150JL5C	JL	275.0	142.0	23408	148.0
470.0	U673D477H150JP5C	JP	202.0	105.0	12844	108.0
470.0	U673D477H150HT5C	HT	185.0	96.0	27089	100.0
560.0	U673D567H150JS5C	JS	163.0	84.0	38050	88.0
680.0	U673D687H150JT5C	JT	137.0	71.0	25294	74.0

* For applications requiring single ended, 3 lead capacitors, change the Part Number U673D to Part Number U674D. Type U674D is only available in terminal style 'A'.

** These values are normally stocked.

U673D and U674D

Vishay Sprague

Aluminum Capacitors
+ 105 °C, Tubular Radial Lead



ORIGINAL RATINGS						
CAPACITANCE (μ F)	PART NUMBER*	CASE CODE	Max. ESR at + 25 °C ($m\Omega$)		Max. RIPPLE at + 105 °C (A) 20 kHz - 100 kHz	Max. IMPEDANCE at 100 kHz ($m\Omega$)
			120 Hz	20 kHz		
200 WVDC at + 105 °C, SURGE = 250 V						
33.0	U673D336H200GE5C	GE	2290.0	1000.0	.651	1040.0
56.0	U673D566H200HE5C	HE	1510.0	670.0	.878	680.0
82.0	U673D826H200JE5C	JE	1090.0	486.0	41275	492.0
150.0	U673D157H200JJ5C	JJ	538.0	240.0	30317	246.0
220.0	U673D227H200JL5C	JL	356.0	160.0	17930	168.0
330.0**	U673D337H200HT5C	HT	242.0	108.0	19419	112.0
390.0	U673D397H200JS5C	JS	214.0	97.0	27820	101.0
470.0	U673D477H200JT5C	JT	179.0	80.0	15432	84.0
250 WVDC at + 105 °C, SURGE = 300 V						
22.0	U673D226H250GE5C	GE	2980.0	780.0	.738	790.0
47.0	U673D476H250GJ5C	GJ	1310.0	370.0	45292	380.0
100.0	U673D107H250GP5C	GP	740.0	195.0	38232	200.0
150.0	U673D157H250HP5C	HP	467.0	125.0	30713	130.0
220.0	U673D227H250JP5C	JP	343.0	94.0	19784	98.0
270.0**	U673D277H250JS5C	JS	270.0	75.0	46478	79.0
330.0	U673D337H250JT5C	JT	222.0	61.0	38112	65.0

* For applications requiring single ended, 3 lead capacitors, change the Part Number U673D to Part Number U674D. Type U674D is only available in terminal style 'A'.

** These values are normally stocked.



Notice

Specifications of the products displayed herein are subject to change without notice. Vishay Intertechnology, Inc., or anyone on its behalf, assumes no responsibility or liability for any errors or inaccuracies.

Information contained herein is intended to provide a product description only. No license, express or implied, by estoppel or otherwise, to any intellectual property rights is granted by this document. Except as provided in Vishay's terms and conditions of sale for such products, Vishay assumes no liability whatsoever, and disclaims any express or implied warranty, relating to sale and/or use of Vishay products including liability or warranties relating to fitness for a particular purpose, merchantability, or infringement of any patent, copyright, or other intellectual property right.

The products shown herein are not designed for use in medical, life-saving, or life-sustaining applications. Customers using or selling these products for use in such applications do so at their own risk and agree to fully indemnify Vishay for any damages resulting from such improper use or sale.