

18-36 V
Input

50 V
Output

10 A
Current

2250 Vdc
Isolation

Half-brick
DC-DC Converter

The IQ24500HZC10 *InQor™* Zeta converter is an isolated, fixed switching frequency DC-DC converter that uses synchronous rectification to achieve extremely high efficiency and power density. The 24 Vin modules feature 2,250 Vdc isolation and low common mode noise. The Zeta series converters offer industry leading useable output power for any standard "half-brick" module. RoHS compliant (see last page).

InQor™



IQ24500HZC10 Module

Operational Features

- Ultra-high efficiency, 94% at full rated load current, 95% at half rated load current
- Delivers up to 10 A of output current (500 W)
- Wide input voltage range: 18 – 36 V, with 50 V 100 ms input voltage transient capability
- Fixed frequency switching provides predictable EMI performance
- No minimum load requirement means no preload resistors required
- Wide output voltage trim range (-50% to +10%), see trim section

Mechanical Features

- Industry standard half-brick pin-out configuration
- Brick size: 2.39" x 2.49" (63.1 x 60.6 mm)
- Total height only 0.512" (13 mm)
- Total weight: 4.3 oz. (123 grams)

Control Features

- On/Off control referenced to input side (positive and negative logic options are available)

Protection Features

- Input under-voltage lockout disables converter at low input voltage conditions
- Output current limit and short circuit protection protects converter and load from damage and consequent hazardous conditions
- Active back bias limit provides smooth startup with external load induced pre-bias
- Latching output over-voltage protection protects load from damaging voltages
- Thermal shutdown protects converter from abnormal environmental conditions

Safety Features

- 2250 V, 30 M Ω input-to-output isolation provides input/output ground separation
- UL/cUL 60950-1 recognized (US & Canada), basic insulation rating
- TUV certified to EN60950-1
- Meets 72/23/EEC and 93/68/EEC directives which facilitates CE Marking in user's end product
- Board and plastic components meet UL94V-0 flammability requirements

Input: 18-36 V
Output: 50 V
Current: 10 A (500 W)
Package: Half-brick

MECHANICAL DIAGRAM

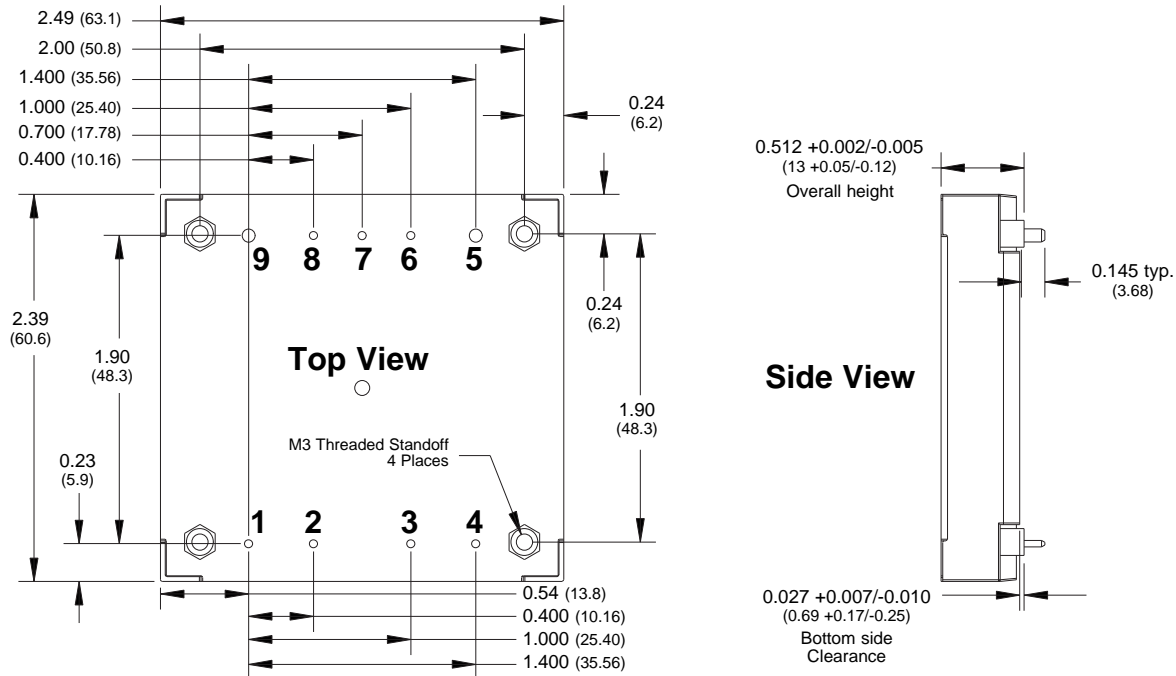

NOTES

- Applied torque per screw should not exceed 6in-lb. (0.7 Nm)
- Baseplate flatness tolerance is 0.004" (0.10 mm) TIR for surface
- Pins 1, 2, 4, 6-8, are 0.040" (1.02mm) diameter with 0.080" (2.03 mm) diameter standoff shoulders
- Pins 5, 9 are 0.080" (2.03 mm) diameter shoulderless pins.
- Other pin extension lengths available
- All Pins: Material - Copper Alloy
Finish - Matte Tin over Nickel plate
- Undimensioned components are shown for visual reference only.
- Weight: 4.3 oz. (123 g) typical
- All dimensions in inches (mm)
Tolerances: x.xx +/-0.02 in. (x.x +/-0.5mm)
x.xxx +/-0.010 in. (x.xx +/-0.25mm)
- Workmanship: Meets or exceeds IPC-A-610C Class II

PIN DESIGNATIONS

Pin No.	Name	Function
1	Vin(+)	Positive input voltage
2	ON/OFF	TTL input to turn converter on and off, referenced to Vin(-), with internal pull up.
3	Reserved	Not connected
4	Vin(-)	Negative input voltage
5	Vout(-)	Negative output voltage
6	SENSE(-)	Return remote sense
7	TRIM	Output voltage trim
8	SENSE(+)	Positive remote sense
9	Vout(+)	Positive output voltage

Notes:

- SENSE(-) should be connected to Vout(-) either remotely or at the converter.
- Leave TRIM pin open for nominal output voltage.
- SENSE(+) should be connected to Vout(+) either remotely or at the converter.



Technical Specification

Input: 18-36 V
Output: 50 V
Current: 10 A (500 W)
Package: Half-brick

IQ24500HXC10 ELECTRICAL CHARACTERISTICS

T_A=25°C, airflow rate=300 LFM, V_{in}=24Vdc unless otherwise noted; full operating temperature range is -40°C to +100°C ambient temperature with appropriate power derating. Specifications subject to change without notice.

Parameter	Min.	Typ.	Max.	Units	Notes & Conditions
ABSOLUTE MAXIMUM RATINGS					
Input Voltage					
Non-Operating			50	V	Continuous
Operating			40	V	Continuous
Operating Transient Protection			50	V	100ms transient, square wave
Isolation Voltage (input to output)			2250	V	Basic insulation, Pollution Degree 2
Operating Temperature	-40		100	°C	
Storage Temperature	-55		125	°C	
Voltage at ON/OFF input pin	-2		18	V	
INPUT CHARACTERISTICS					
Operating Input Voltage Range	18	24	36	V	50 V transient for 100 ms
Input Under-Voltage Lockout					
Turn-On Voltage Threshold	16.5	17.0	17.5	V	
Turn-Off Voltage Threshold	15.0	15.5	16.0	V	
Lockout Voltage Hysteresis	1.0	1.5	2.0	V	
Maximum Input Current			38	A	100% Load, 18 Vin, trimmed up 10%
No-Load Input Current		300	350	mA	
Disabled Input Current		100	125	mA	
Response to Input Transient		1.5		V	0.25 V/μs input transient
Input Reflected Ripple Current		10	25	mA	RMS thru 3.3 μH inductor
Input Terminal Ripple Current		500		mA	RMS
Recommended Input Fuse			40	A	Fast blow external fuse recommended
Input Filter Component Values (L\C)		0.34\23		μH\μF	Internal values; see Figure E
Recommended External Input Capacitance		470		μF	Typical ESR 0.1-0.2 Ω
OUTPUT CHARACTERISTICS					
Output Voltage Set Point	48.60	50.00	51.35	V	
Output Voltage Regulation					
Over Line ¹		±0.25\125		%\mV	
Over Load ¹		±0.25\125		%\mV	
Over Temperature		±0.380	±1.000	V	
Total Output Voltage Range	48.5		51.45	V	Over sample, line, load, temperature & life
Output Voltage Ripple and Noise ²					20 MHz bandwidth
Peak-to-Peak		250	300	mV	Full Load
RMS		60	75	mV	Full Load
Operating Output Current Range	0		10	A	Subject to thermal derating
Output DC Current-Limit Inception	11	12	13	A	Output Voltage 10% Low
Output DC Current-Limit Shutdown Voltage ³		20		V	
Back-Drive Current Limit while Enabled	2	3	4	A	Negative current drawn from output source
Back-Drive Current Limit while Disabled	0	3	7	mA	Negative current drawn from output source
Maximum Output Capacitance			1	mF	10 A Resistive Load
DYNAMIC CHARACTERISTICS					
Output Voltage during Load Current Transient					
For a Step Change in Output Current (0.1 A/μs)		2		V	50% to 75% to 50% load max, 200 μF load cap
For a Step Change in Output Current (5 A/μs)		2		V	"
Settling Time		8		ms	To within 1% Vout nom
Turn-On Transient					
Turn-On Time	24	35	40	ms	Full load, ON/OFF to Vout=90% nom.
Output Voltage Overshoot			2	%	No load, 1mF load cap
EFFICIENCY					
100% Load		94		%	Figures 1 & 2
50% Load		95		%	Figures 1 & 2
TEMPERATURE LIMITS FOR POWER DERATING CURVES					
Semiconductor Junction Temperature			125	°C	Package rated to 150°C
Board Temperature			125	°C	UL rated max operating temp 130°C
Transformer Temperature			125	°C	
ISOLATION CHARACTERISTICS					
Isolation Voltage (dielectric strength)		2250		V	
Isolation Resistance		30		MΩ	
Isolation Capacitance ⁴		1000		pF	

Note 1: Line and load regulation is limited by duty cycle quantization and does not indicate a shift in the internal voltage reference.

Note 2: For applications requiring reduced output voltage ripple and noise, consult SynQor applications support (e-mail: support@synqor.com).

Note 3: If the output voltage falls below the Output DC Current Limit Shutdown Voltage for more than 50ms, then the unit will enter into hiccup mode, with a 500ms off-time.

Note 4: Higher values of isolation capacitance can be added external to the module.



Technical Specification

Input: 18-36 V
Output: 50 V
Current: 10 A (500 W)
Package: Half-brick

ELECTRICAL CHARACTERISTICS (Continued)

Parameter	Min.	Typ.	Max.	Units	Notes & Conditions
FEATURE CHARACTERISTICS					
Switching Frequency Regulation Stage	233	235	237	kHz	Over sample, temp & life
Switching Frequency Isolation Stage	116.5	117.5	118.5	kHz	Over sample, temp & life
ON/OFF Control (Option P)					
Off-State Voltage	-2.0		1.0	V	
On-State Voltage	4.0		18	V	
ON/OFF Control (Option N)					
Off-State Voltage	4.0		18	V	
On-State Voltage	-2		1.0	V	
ON/OFF Control (Either Option)					Figure A
ON/OFF Control Hysteresis		1.5		V	
Pull-Up Voltage	4.75	5.00	5.25	V	
Pull Up Resistance		10		kΩ	
Output Voltage Trim Range	-50		+10	%	Measured across Pins 9 & 5; see trim section
Output Over-Voltage Protection	113	118	123	%	Over full temp range; % of nominal Vout
Over-Temperature Shutdown		120		°C	Average PCB Temperature
Over-Temperature Shutdown Restart Hysteresis		10		°C	
RELIABILITY CHARACTERISTICS					
Calculated MTBF (Telcordia)		TBD		10 ⁶ Hrs.	TR-NWT-000332; 80% load, 300LFM, 40°C T _a
Calculated MTBF (MIL-217)		TBD		10 ⁶ Hrs.	MIL-HDBK-217F; 80% load, 300LFM, 40°C T _a
Field Demonstrated MTBF				10 ⁶ Hrs.	See website for details

STANDARDS COMPLIANCE

Parameter	Notes & Conditions
STANDARDS COMPLIANCE	
UL/cUL 60950-1	File # E194341, Basic insulation
EN60950-1	Certified by TUV
Needle Flame Test (IEC 695-2-2)	Test on entire assembly; board & plastic components UL94V-0 compliant
IEC 61000-4-2	ESD test, 8 kV - NP, 15 kV air - NP (Normal Performance)

Note: An external input fuse must always be used to meet these safety requirements. Contact SynQor for official safety certificates on new releases or download from the SynQor website.

QUALIFICATION TESTING

Parameter	# Units	Test Conditions
QUALIFICATION TESTING		
Life Test	32	95% rated Vin and load, units at derating point, 1000 hours
Vibration	5	10-55 Hz sweep, 0.060" total excursion, 1 min./sweep, 120 sweeps for 3 axis
Mechanical Shock	5	100g minimum, 2 drops in x and y axis, 1 drop in z axis
Temperature Cycling	10	-40 °C to 100 °C, unit temp. ramp 15 °C/min., 500 cycles
Power/Thermal Cycling	5	Toperating = min to max, Vin = min to max, full load, 100 cycles
Design Marginality	5	Tmin-10 °C to Tmax+10 °C, 5 °C steps, Vin = min to max, 0-105% load
Humidity	5	85 °C, 85% RH, 1000 hours, continuous Vin applied except 5 min/day
Solderability	15 pins	MIL-STD-883, method 2003

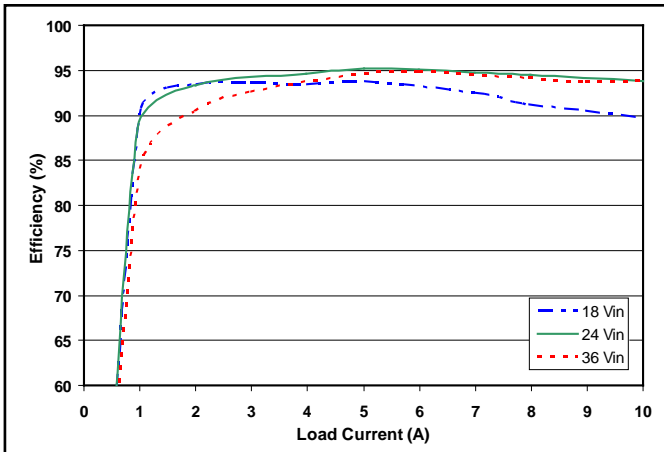

Figure 1: Efficiency at nominal output voltage vs. load current for minimum, nominal, and maximum input voltage at 25°C.

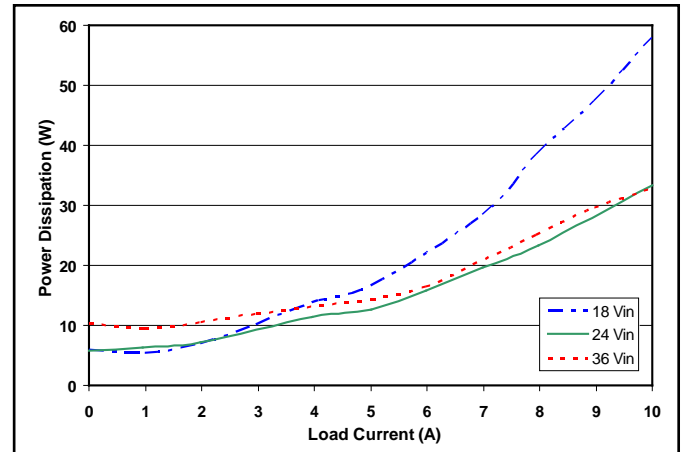

Figure 2: Power dissipation at nominal output voltage vs. load current for minimum, nominal, and maximum input voltage at 25°C.

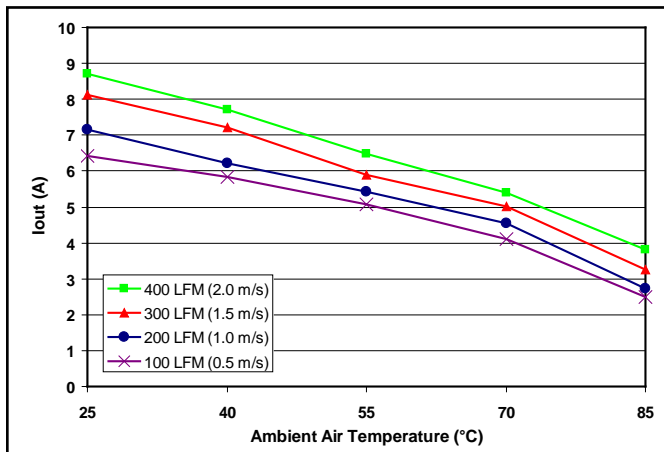

Figure 3: Encased converter (without heatsink) max. output power derating vs. ambient air temperature for airflow rates of 100 LFM through 400 LFM. Air flows across the converter from input to output (nominal input voltage).

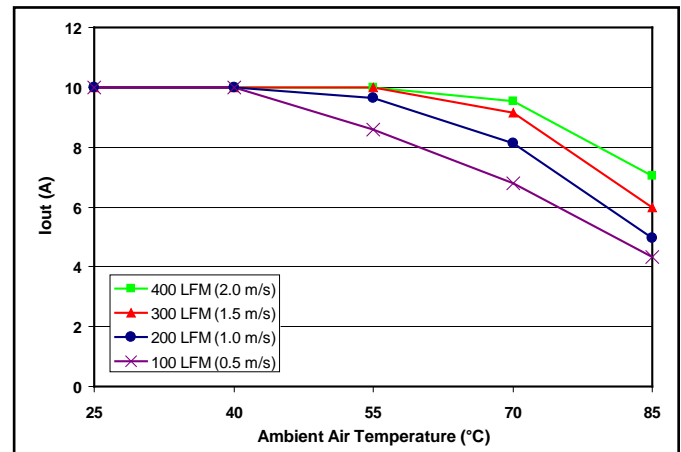

Figure 4: Encased converter (with 1/2" heatsink) max. output power derating vs. ambient air temperature for airflow rates of 100 LFM through 400 LFM. Air flows across the converter from input to output (nominal input voltage).

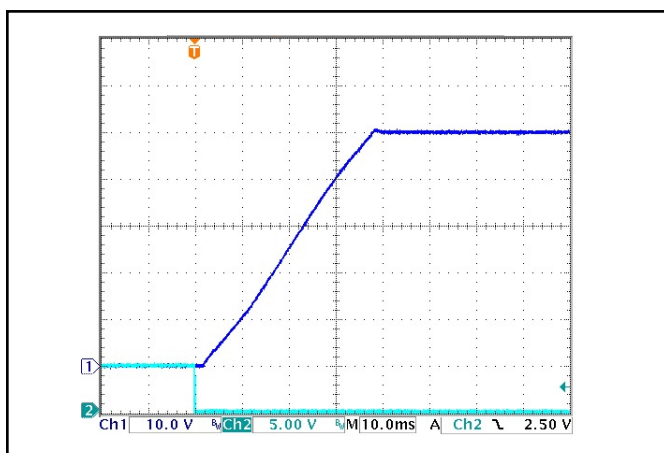

Figure 5: Turn-on transient at full load (resistive load) (10 ms/div).
 Ch 1: Vout (10 V/div)
 Ch 2: ON/OFF input (5 V/div)

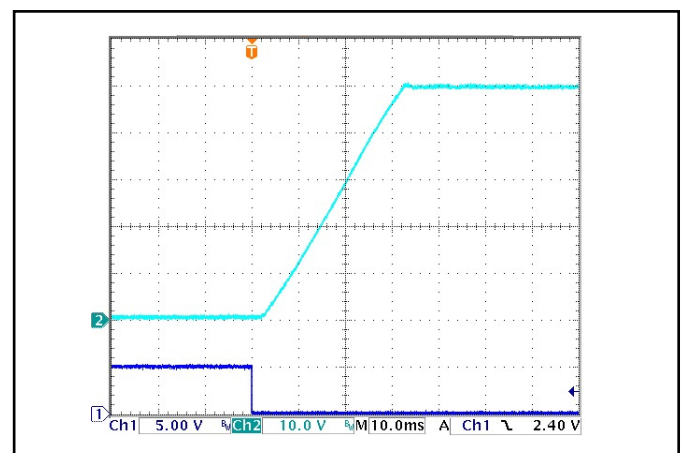

Figure 6: Turn-on transient at zero load (10 ms/div).
 Ch 1: ON/OFF input (5 V/div)
 Ch 2: Vout (10 V/div)

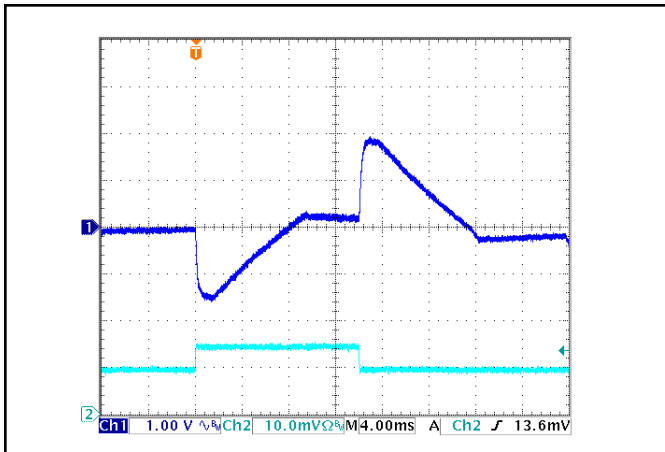

Figure 7: Output voltage response to step-change in load current (50%-75%-50% of $I_{out(max)}$; $di/dt = 0.1 \text{ A}/\mu\text{s}$; 1 ms/div). Load cap: 1 μF ceramic and 330 μF , 15 m Ω ESR electrolytic capacitors. Top trace: Vout (1 V/div). Bottom trace: I_{out} (5 A/div).

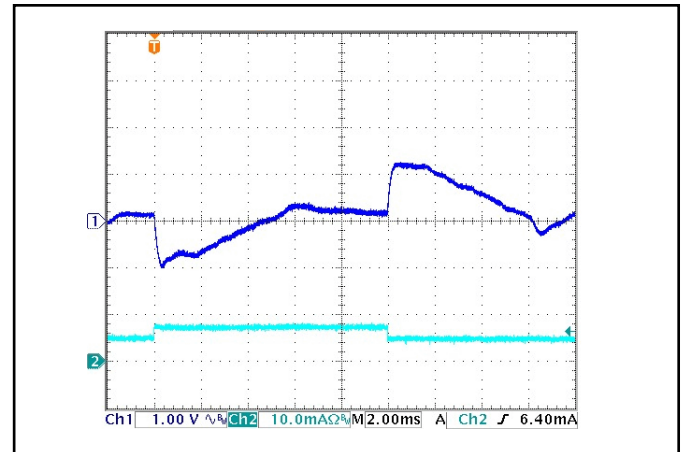

Figure 8: Output voltage response to step-change in load current (50%-75%-50% of $I_{out(max)}$; $di/dt = 5 \text{ A}/\mu\text{s}$; 2 ms/div). Load cap: 330 μF , 15 m Ω ESR electrolytic capacitor. Top trace: Vout (1.0 V/div). Bottom trace: I_{out} 10 A/div).

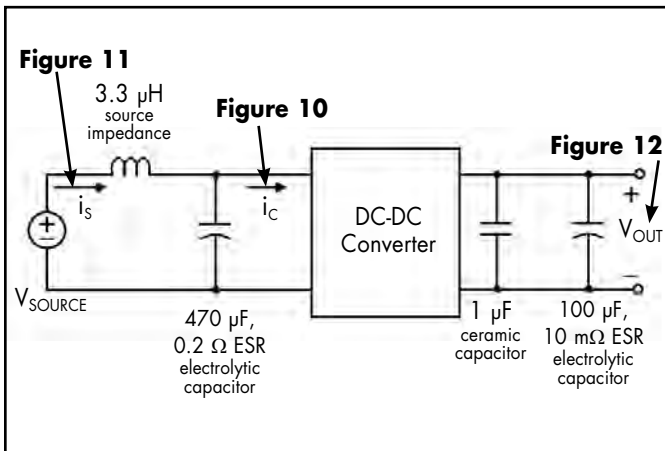

Figure 9: Test set-up diagram showing measurement points for Input Terminal Ripple Current (Figure 10), Input Reflected Ripple Current (Figure 11) and Output Voltage Ripple (Figure 12).

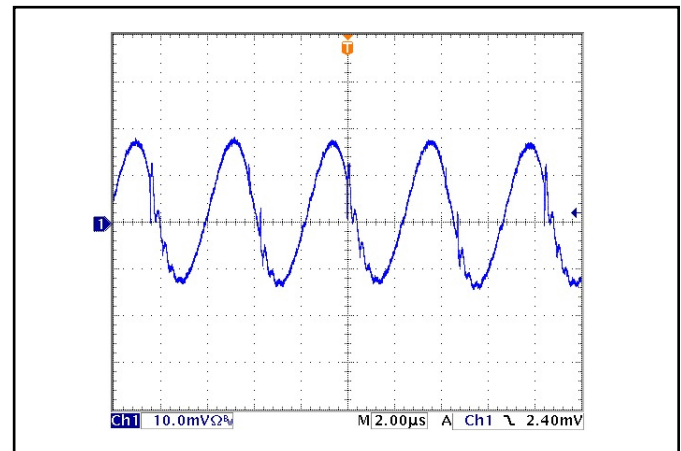

Figure 10: Input Terminal Ripple Current, i_c , at full rated output current and nominal input voltage with 3.3 μH source impedance and 470 μF electrolytic capacitor (200 mA/div; 2 $\mu\text{s}/\text{div}$). See Figure 9.

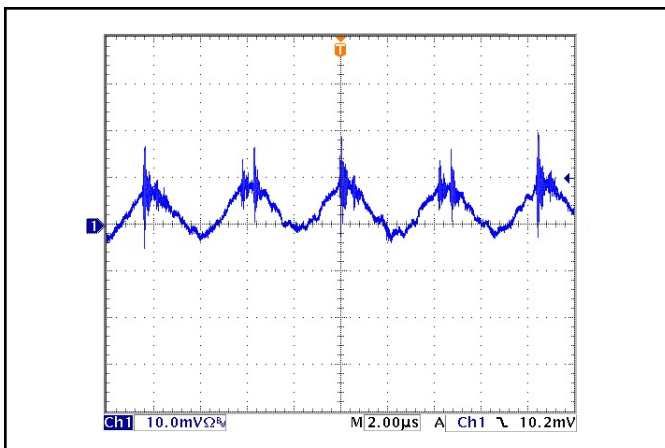

Figure 11: Input reflected ripple current, i_s , through a 3.3 μH source inductor, using a 470 μF input capacitor, at nominal input voltage and rated load current (10 mA/div; 2 $\mu\text{s}/\text{div}$). See Figure 9.

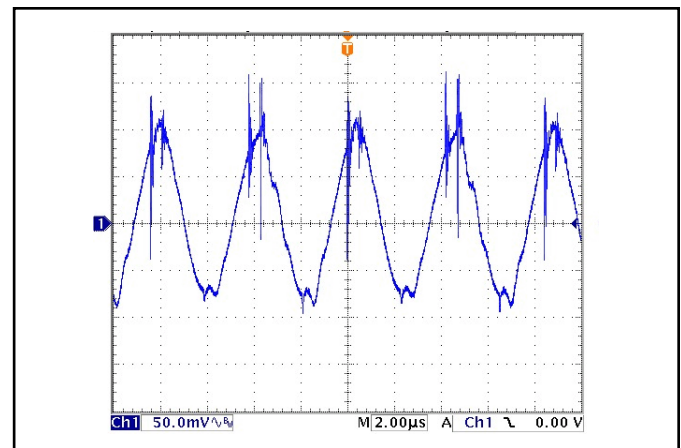

Figure 12: Output voltage ripple at nominal input voltage and rated load current (50 mV/div; 2 $\mu\text{s}/\text{div}$). Load capacitance: 1 μF ceramic capacitor and 100 μF electrolytic capacitor. Bandwidth: 20 MHz. See Figure 9.

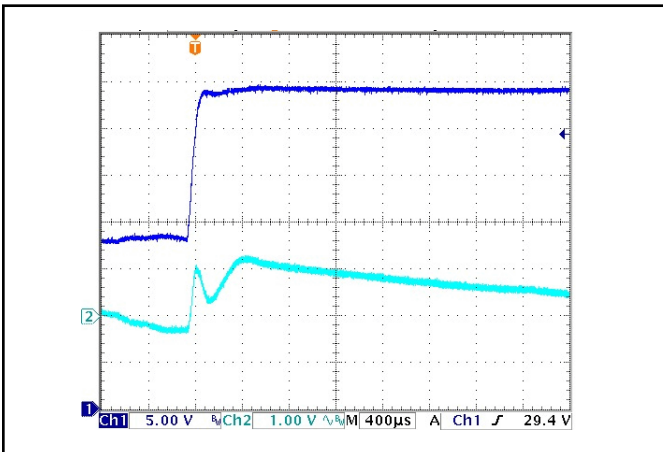

Figure 13: Output voltage response to step-change in input voltage (18 V to 36 V in 200 μ s; 400 μ s/div). Load cap: 470 μ F, 15 m Ω ESR electrolytic capacitor. Top trace: Vin (5.0 V/div). Bottom trace: Vout (1.0 V/div), at zero load current.

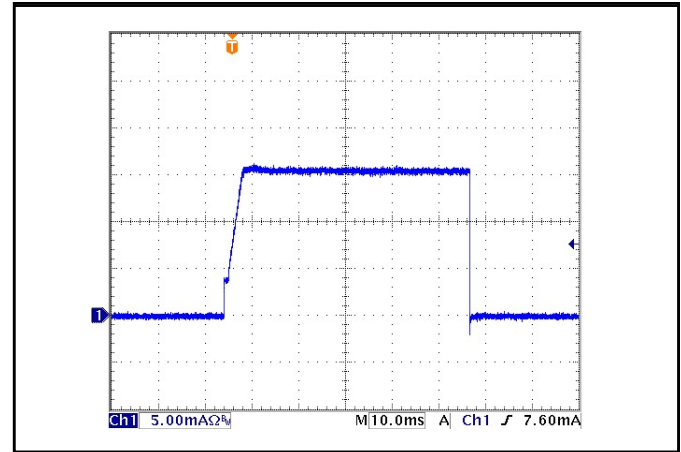

Figure 14: Load current (5 A/div; 10 ms/div) as a function of time when the converter attempts to turn on into a 1 m Ω short circuit.

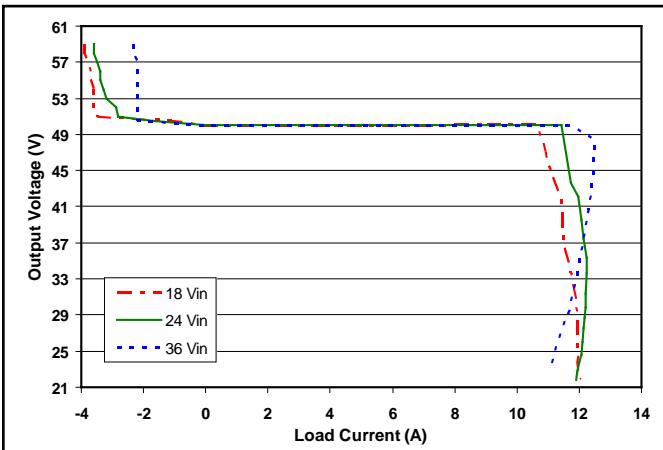

Figure 15: Output voltage vs. load current showing typical current limit curves and OVP shutdown point.

BASIC OPERATION AND FEATURES

The converter series uses a two-stage power conversion topology. The first stage keeps the output voltage constant over variations in line, load, and temperature. The second stage uses a transformer to provide the functions of input/output isolation and voltage step-down to achieve the low output voltage required.

Both the first stage and the second stage switch at a fixed frequency for predictable EMI performance. Rectification of the transformer's output is accomplished with synchronous rectifiers. These devices, which are MOSFETs with a very low on-state resistance, dissipate significantly less energy than Schottky diodes, enabling the converter to achieve high efficiency.

The series of half-brick, quarter-brick and eighth-brick converters uses the industry standard footprint and pin-out configuration.

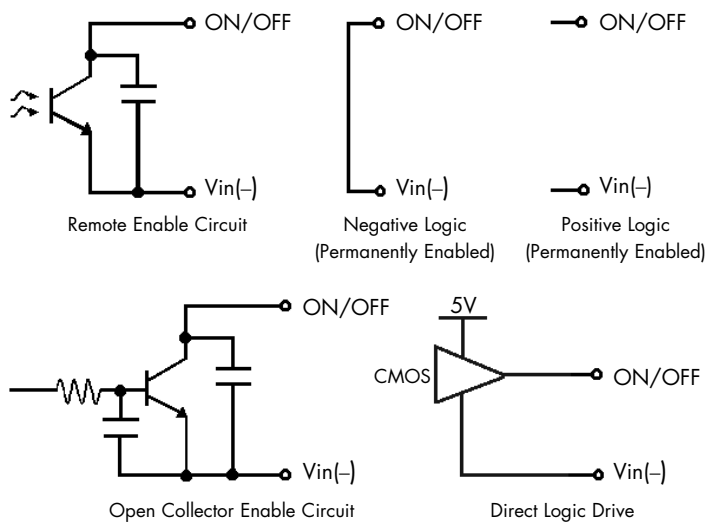

Figure A: Various circuits for driving the ON/OFF pin.

CONTROL FEATURES

REMOTE ON/OFF (Pin 2): The ON/OFF input, Pin 2, permits the user to control when the converter is on or off. This input is referenced to the return terminal of the input bus, Vin(-). The converter is available with either positive or negative logic used for the ON/OFF input.

In the positive logic version, the ON/OFF input is active high (meaning that a high voltage turns the converter on). In the negative logic version, the ON/OFF signal is active low (meaning that a low voltage turns the converter on). Figure A details five possible circuits for driving the ON/OFF pin.

REMOTE SENSE(±) (Pins 8 and 6): The SENSE(±) inputs correct for voltage drops along the conductors that connect the converter's output pins to the load.

Pin 8 should be connected to Vout(+) and Pin 6 should be connected to Vout(-) at the point on the board where regulation is desired. If these connections are not made, the converter will deliver an output voltage that is slightly higher than its specified value.

Note: The output over-voltage protection circuit senses the voltage across the sense leads (pins 8 and 6) to determine when it should trigger, not the voltage across the converter's output pins (pins 9 and 5).

OUTPUT VOLTAGE TRIM (Pin 7): The TRIM input permits the user to adjust the output voltage across the sense leads up or down according to the trim range specifications. SynQor uses industry standard trim equations.

To decrease the output voltage, the user should connect a resistor between Pin 7 (TRIM) and Pin 6 (SENSE(-) input). For a desired decrease of the nominal output voltage, the value of the resistor should be:

$$R_{\text{trim-down}} = \left(\frac{100\%}{\Delta} \right) - 2 \text{ k}\Omega$$

where

$$\Delta\% = \left| \frac{V_{\text{nominal}} - V_{\text{desired}}}{V_{\text{nominal}}} \right| \times 100\%$$

To increase the output voltage, the user should connect a resistor between Pin 7 (TRIM) and Pin 8 (SENSE(+) input). For a desired increase of the nominal output voltage, the value of the resistor should be

$$R_{\text{trim-up}} = \frac{\left(\frac{V_{\text{nominal}}}{1.225} - 2 \right) \times V_{\text{DES}} + V_{\text{NOM}}}{V_{\text{DES}} - V_{\text{NOM}}} \text{ k}\Omega$$

Figure B graphs the relationship between the trim resistor value, Rtrim-up and Rtrim-down, showing the total range the output voltage can be trimmed up or down.

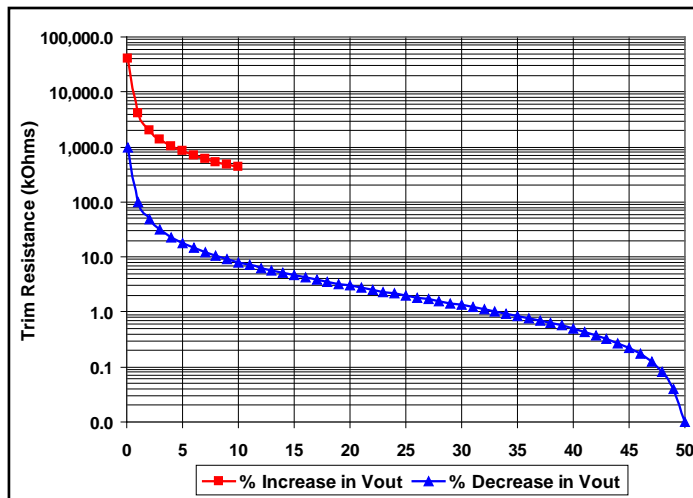

Figure B: Trim Graph for 50 Vout module

Note: The TRIM feature does not affect the voltage at which the output over-voltage protection circuit is triggered. Trimming the output voltage too high may cause the over-voltage protection circuit to engage, particularly during transients.

It is not necessary for the user to add capacitance at the Trim pin. The node is internally filtered to eliminate noise.

Total DC Variation of Vout: For the converter to meet its full specifications, the maximum variation of the DC value of Vout, due to both trimming and remote load voltage drops, should not be greater than that specified for the output voltage trim range.

PROTECTION FEATURES

Input Under-Voltage Lockout: The converter is designed to turn off when the input voltage is too low, helping to avoid an input system instability problem, which is described in more detail in the application note titled "Input System Instability" on the SynQor website. The lockout circuitry is a comparator with DC hysteresis. When the input voltage is rising, it must exceed the typical "Turn-On Voltage Threshold" value* before the converter will turn on. Once the converter is on, the input voltage must fall below the typical Turn-Off Voltage Threshold value before the converter will turn off.

Output Current Limit: If the output current exceeds the "Output DC Current Limit Inception" point*, then a fast linear current limit controller will reduce the output voltage to maintain a constant output current. If as a result, the output voltage falls below the "Output DC Current Limit Shutdown Voltage"* for more than 50 ms, then the unit will enter into hiccup mode, with a 500 ms off-time. The unit will then automatically attempt to restart.

Back-Drive Current Limit: If there is negative output current of a magnitude larger than the "Back-Drive Current Limit while Enabled" specification*, then a fast back-drive limit controller will increase the output voltage to maintain a constant output current. If this results in the output voltage exceeding the "Output Over-Voltage Protection" threshold*, then the unit will shut down. The full I-V output characteristics can be seen in Figure 15.

Output Over-Voltage Limit: If the voltage directly across the output pins exceeds the "Output Over-Voltage Protection" threshold*, the converter will immediately stop switching. This shutdown is latching; unlike other shutdown types, the converter will not restart unless the input power is cycled or the ON/OFF input is toggled.

Over-Temperature Shutdown: A temperature sensor on the converter senses the average temperature of the module. The thermal shutdown circuit is designed to turn the converter off when the temperature at the sensed location reaches the "Over-Temperature Shutdown" value*. It will allow the converter to turn on again when the temperature of the sensed location falls by the amount of the "Over-Temperature Shutdown Restart Hysteresis" value*.

* See Electrical Characteristics page.

APPLICATION CONSIDERATIONS

Input System Instability: This condition can occur because any DC-DC converter appears incrementally as a negative resistance load. A detailed application note titled "Input System Instability" is available on the SynQor website which provides an understanding of why this instability arises, and shows the preferred solution for correcting it.

Application Circuits: Figure C below provides a typical circuit diagram which details the input filtering and voltage trimming.

Input Filtering and External Input Capacitance: Figure D below shows the internal input filter components. This filter dramatically reduces input terminal ripple current, which otherwise could exceed the rating of an external electrolytic input capacitor. The recommended external input capacitance is specified in the Input Characteristics section on the Electrical Specifications page. More detailed information is available in the application note titled "EMI Characteristics" on the SynQor website.

Output Filtering and External Output Capacitance: Figure D below shows the internal output filter components. This filter dramatically reduces output voltage ripple. However, some minimum external output capacitance is required, as specified in the Output Characteristics section on the Electrical Specifications page. No damage will occur without this capacitor connected, but peak output voltage ripple will be much higher.

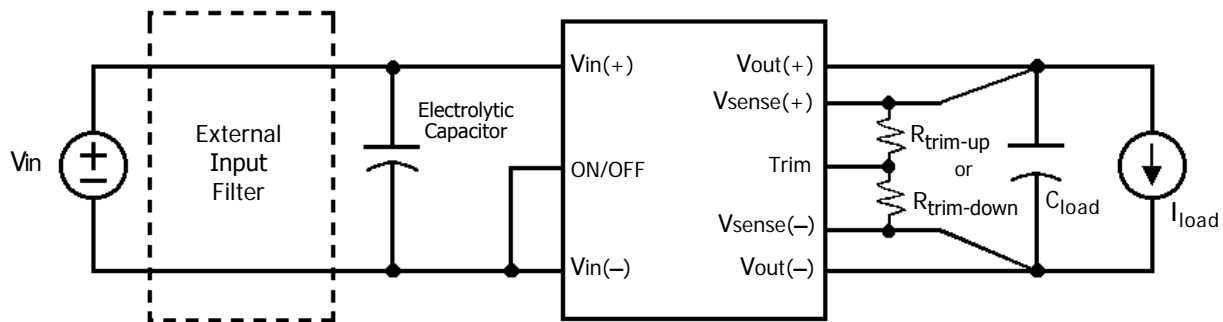

Figure D: Typical application circuit (negative logic unit, permanently enabled).

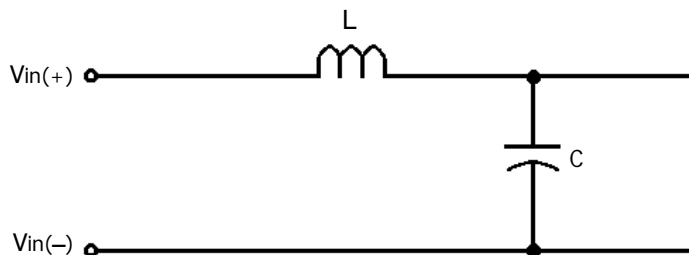

Figure E: Internal Input Filter Diagram (component values listed on the specifications page).

Startup Inhibit Period: The Startup Inhibit Period ensures that the converter will remain off for approximately 200 ms when it is shut down for any reason. When an output short is present, this generates a 5 Hz "hiccup mode," which prevents the converter from overheating. In all, there are seven ways that the converter can be shut down, initiating a Startup Inhibit Period:

- Input Under-Voltage Lockout
- Output Over-Voltage Protection
- Over Temperature Shutdown
- Current Limit
- Short Circuit Protection
- Turned off by the ON/OFF input

Figure F shows three turn-on scenarios, where a Startup Inhibit Period is initiated at t_0 , t_1 , and t_2 :

Before time t_0 , when the input voltage is below the UVL threshold, the unit is disabled by the Input Under-Voltage Lockout feature. When the input voltage rises above the UVL threshold, the Input Under-Voltage Lockout is released, and a Startup Inhibit Period is initiated. At the end of this delay, the ON/OFF pin is evaluated, and since it is active, the unit turns on.

At time t_1 , the unit is disabled by the ON/OFF pin, and it cannot be enabled again until the Startup Inhibit Period has elapsed.

When the ON/OFF pin goes high after t_2 , the Startup Inhibit Period has elapsed, and the output turns on within the typical Turn-On Time.

Thermal Considerations: The maximum operating base-plate temperature, T_B , is 100 °C. As long as the user's thermal system keeps $T_B \leq 100$ °C, the converter can deliver its full rated power.

A power derating curve can be calculated for any heatsink that is attached to the base-plate of the converter. It is only necessary to determine the thermal resistance, R_{THBA} , of the chosen heatsink between the base-plate and the ambient air for a given airflow rate. This information is usually available from the heatsink vendor. The following formula can be used to determine the maximum power the converter can dissipate for a given thermal condition if its base-plate is to be no higher than 100 °C.

$$P_{diss}^{max} = \frac{100 \text{ }^\circ\text{C} - T_A}{R_{THBA}}$$

This value of power dissipation can then be used in conjunction with the data shown in Figure 2 to determine the maximum load current (and power) that the converter can deliver in the given thermal condition.

For convenience, Figures 3 and 4 provide Power derating curves for an encased converter without a heatsink and with a typical heatsink.

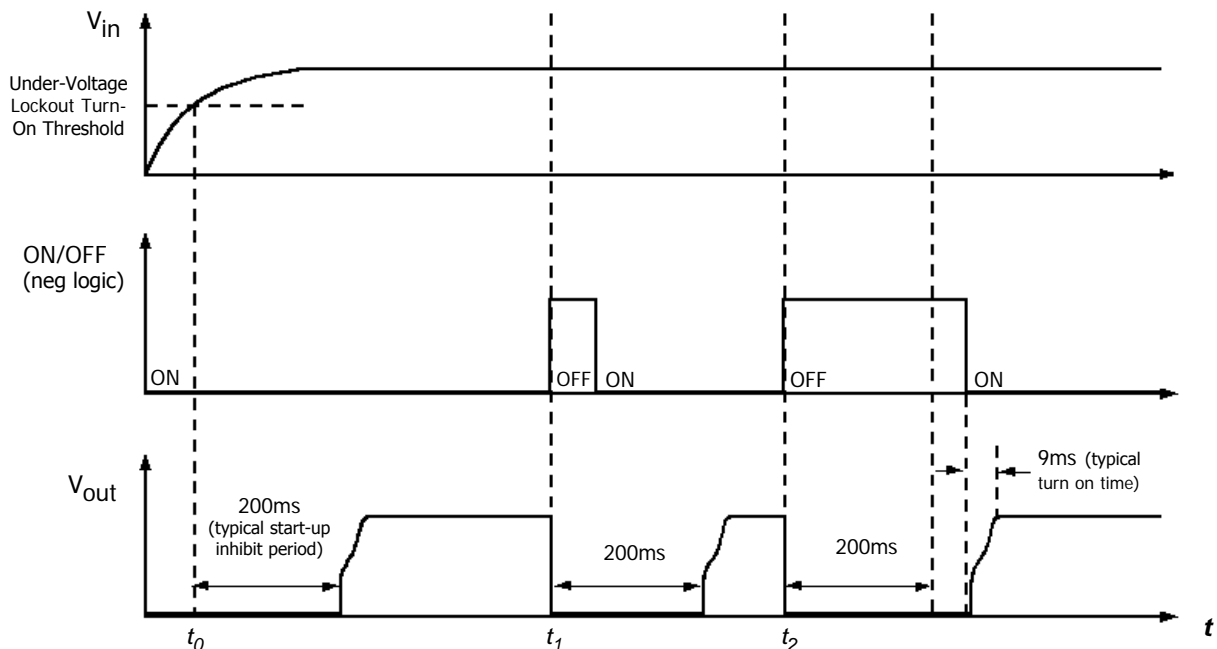

Figure F: Startup Inhibit Period (turn-on time not to scale)



Technical Specification

Input: 18-36 V
Output: 50 V
Current: 10 A (500 W)
Package: Half-brick

PART NUMBERING SYSTEM

The part numbering system for SynQor's dc-dc converters follows the format shown in the example below.

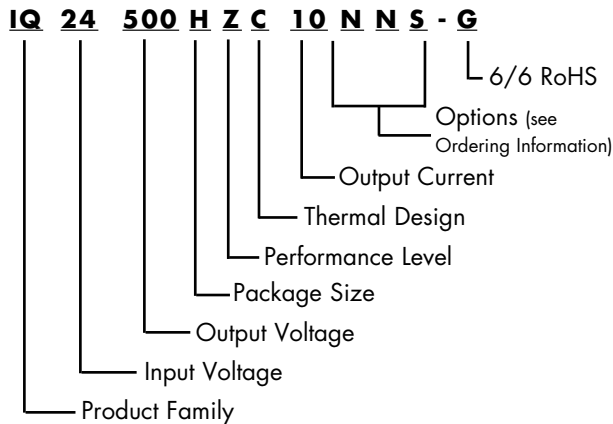

The first 12 characters comprise the base part number and the last 3 characters indicate available options. The "-G" suffix indicates 6/6 RoHS compliance.

Application Notes

A variety of application notes and technical white papers can be downloaded in pdf format from our website.

RoHS Compliance: The EU led RoHS (Restriction of Hazardous Substances) Directive bans the use of Lead, Cadmium, Hexavalent Chromium, Mercury, Polybrominated Biphenyls (PBB), and Polybrominated Diphenyl Ether (PBDE) in Electrical and Electronic Equipment. This SynQor product is 6/6 RoHS compliant. For more information please refer to SynQor's RoHS addendum available at our RoHS Compliance / Lead Free Initiative web page or e-mail us at rohs@synqor.com.

Contact SynQor for further information:

Phone: 978-849-0600
Toll Free: 888-567-9596
Fax: 978-849-0602
E-mail: power@synqor.com
Web: www.synqor.com
Address: 155 Swanson Road
 Boxborough, MA 01719
 USA

ORDERING INFORMATION

The tables below show the valid model numbers and ordering options for converters in this product family. When ordering SynQor converters, please ensure that you use the complete 15 character part number consisting of the 12 character base part number and the additional 3 characters for options. A "-G" suffix indicates the product is 6/6 RoHS compliant.

Model Number	Input Voltage	Output Voltage	Max Output Current
IQ24280HZC18xyz	18 - 36 V	28 V	18 A
IQ24500HZC10xyz	18 - 36 V	50 V	10 A

The following options must be included in place of the x y z spaces in the model numbers listed above.

Options Description: x y z		
Enable Logic	Pin Style	Feature Set
P - Positive N - Negative	K - 0.110" N - 0.145" R - 0.180" Y - 0.250"	S - Standard

PATENTS

SynQor holds the following patents, one or more of which might apply to this product:

5,999,417	6,222,742	6,545,890	6,577,109
6,594,159	6,731,520	6,894,468	6,896,526
6,927,987	7,050,309	7,072,190	7,085,146
7,119,524	7,269,034	7,272,021	7,272,023

Warranty

SynQor offers a three (2) year limited warranty. Complete warranty information is listed on our website or is available upon request from SynQor.

Information furnished by SynQor is believed to be accurate and reliable. However, no responsibility is assumed by SynQor for its use, nor for any infringements of patents or other rights of third parties which may result from its use. No license is granted by implication or otherwise under any patent or patent rights of SynQor.