

# DATA SHEET

## **SURFACE-MOUNT CERAMIC MULTILAYER CAPACITORS**

Mid-voltage: NP0/X7R  
(Pb Free & RoHS compliant)

100 V TO 500 V

10 pF to 470 nF



**SCOPE**

This specification describes Mid-voltage NP0/X7R series chip capacitors with lead-free terminations.

**APPLICATIONS**

- PCs, hard disk, game PCs
- Power supplies
- LCD panel
- ADSL, modem

**FEATURES**

- Supplied in tape on reel
- Nickel-barrier end termination

**ORDERING INFORMATION**

Components may be ordered by using either a Phycomp’s unique I2NC or Phycomp clear text code.

**PHYCOMP ORDERING CODE**

**I2NC CODE**

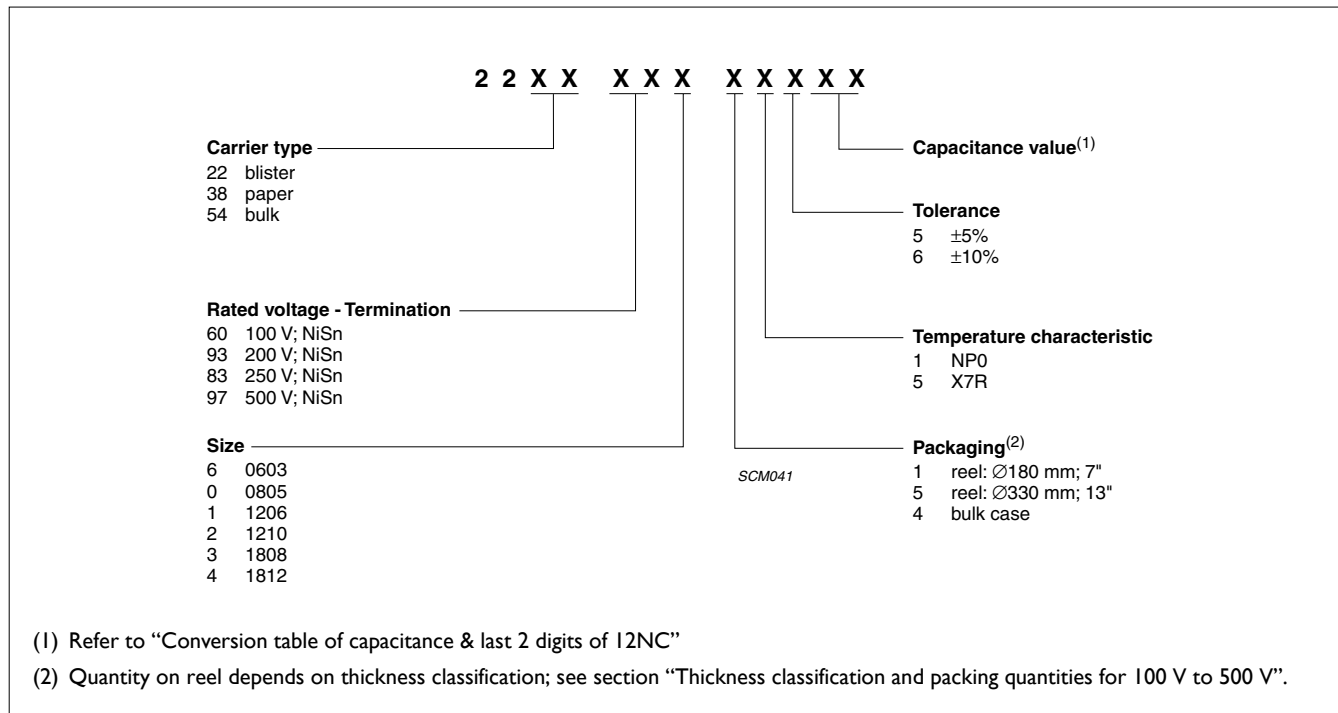

Conversion table of capacitance & last 2 digits of I2NC for NP0

CAP. (pF)	LAST 2 DIGITS OF I2NC	CAP. (pF)	LAST 2 DIGITS OF I2NC	CAP. (pF)	LAST 2 DIGITS OF I2NC	CAP. (pF)	LAST 2 DIGITS OF I2NC	CAP. (pF)	LAST 2 DIGITS OF I2NC
1.0	10	8.2	22	68	34	560	46	4,700	58
1.2	11	10	23	82	35	680	47	5,600	59
1.5	12	12	24	100	36	820	48	6,800	61
1.8	13	15	25	120	37	1,000	49	8,200	62
2.2	14	18	26	150	38	1,200	51	10,000	63
2.7	15	22	27	180	39	1,500	52	12,000	64
3.3	16	27	28	220	41	1,800	53	15,000	65
3.9	17	33	29	270	42	2,200	54	18,000	66
4.7	18	39	31	330	43	2,700	55	22,000	67
5.6	19	47	32	390	44	3,300	56		
6.8	21	56	33	470	45	3,900	57		

Conversion table of capacitance & last 2 digits of 12NC for X7R

CAP. (pF)	LAST 2 DIGITS OF 12NC	CAP. (pF)	LAST 2 DIGITS OF 12NC	CAP. (pF)	LAST 2 DIGITS OF 12NC	CAP. (pF)	LAST 2 DIGITS OF 12NC	CAP. (pF)	LAST 2 DIGITS OF 12NC
100	10	680	21	4,700	32	33,000	43	220,000	54
120	11	820	22	5,600	33	39,000	44	270,000	55
150	12	1,000	23	6,800	34	47,000	45	330,000	56
180	13	1,200	24	8,200	35	56,000	46	390,000	57
220	14	1,500	25	10,000	36	68,000	47	470,000	58
270	15	1,800	26	12,000	37	82,000	48	560,000	59
330	16	2,200	27	15,000	38	100,000	49	680,000	61
390	17	2,700	28	18,000	39	120,000	51	820,000	62
470	18	3,300	29	22,000	41	150,000	52		
560	19	3,900	31	27,000	42	180,000	53		

**CTC CODE**

Size code	Temp. Char.	Capacitance	Tolerance	Rated voltage	Termination	Packing	Marking	Series
0603	CG = NP0	225 = 2,200,000 pF;	J = ±5%	0 = 100 V	B = NiSn	2 = 180 mm; 7" paper	0 = No marking	0 = conv.
0805	2R = X7R	the third digit signifies	K = ±10%	B = 200 V		3 = 330 mm; 13" paper		ceramic
1206		the multiplying factor:		C = 250 V		B = 180 mm; 7" blister		D = BME
1210		0 = × 1		D = 500 V		F = 330 mm; 13" blister		
1808		1 = × 1,0				P = Bulk case		
1812		2 = × 1,00						
		3 = × 1,000						
		4 = × 10,000						
		5 = × 100,000						
		6 = × 1,000,000						
		8 = × 0,01						
		9 = × 0,1						

Example: 0603CG100J0B200

**CONSTRUCTION**

The capacitor consists of a rectangular block of ceramic dielectric in which a number of interleaved metal electrodes are contained. This structure gives rise to a high capacitance per unit volume.

The inner electrodes are connected to the two end terminations and finally covered with a layer of plated tin (NiSn). The terminations are lead-free. A cross section of the structure is shown in Fig. I.

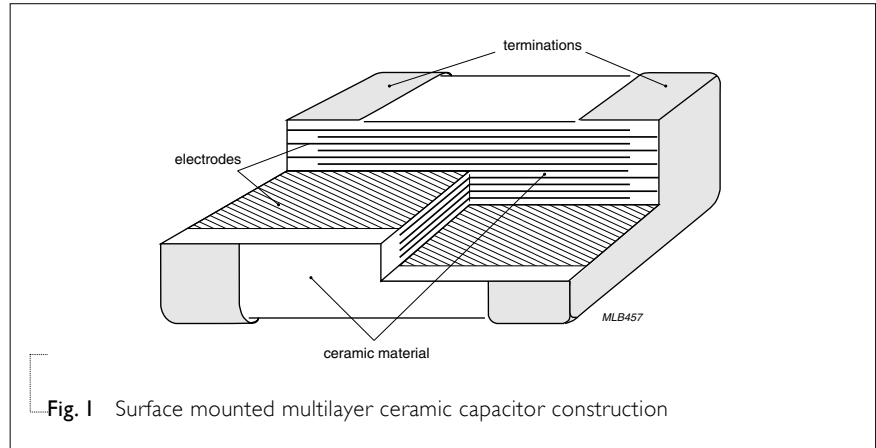

Fig. I Surface mounted multilayer ceramic capacitor construction

**DIMENSION**

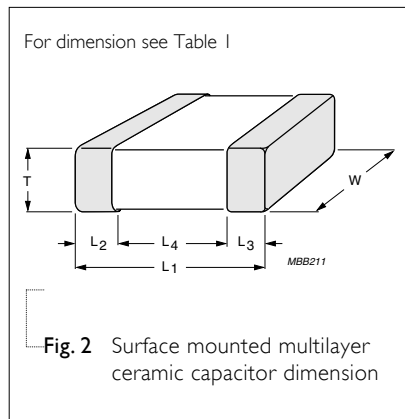

Fig. 2 Surface mounted multilayer ceramic capacitor dimension

Table I

TYPE	CC0603	CC0805	CC1206	CC1210	CC1808	CC1812
L <sub>1</sub> (mm)	1.6 ±0.10	2.0 ±0.20	3.2±0.20	3.2 ±0.20	4.5 ±0.30	4.5 ±0.30
W (mm)	0.8 ±0.07	1.25 ±0.20	1.6±0.20	2.5 ±0.20	2.0 ±0.30	3.2 ±0.30
T (mm)	Refer to table 2 to 7					
L <sub>2</sub> /L <sub>3</sub> (mm)	min. 0.20	0.25	0.25	0.25	0.25	0.25
	max. 0.50	0.75	0.75	0.75	0.75	0.75
L <sub>4</sub> (mm)	min. 0.60	0.55	1.40	1.40	2.20	2.20

**CAPACITANCE RANGE & THICKNESS FOR NPO 100V**

Table 2 For NPO 100 V sizes from 0603 to 1812

CAPACITANCE (pF)	100 V 0603	0805	1206	1210	1808	1812
10						
12						
15						
18						
22						
27						
33						
39						
47						
56						
68						
82						
100	0.8 ±0.10	0.6 ±0.10				
120						
150			0.6 ±0.10			
180						
220						
270						
330						
390						
470						
560						
680						
820						
1,000						
1,200						
1,500		0.85 ±0.10				
1,800						
2,200				0.6 ±0.10	1.25 ±0.20	1.25 ±0.20
2,700						
3,300		1.25 ±0.20				
3,900			0.85 ±0.10			
4,700						
5,600			1.15±0.15	0.85 ±0.10		

Table 2 For NP0 100 V sizes from 0603 to 1812 (continued)

CAPACITANCE (pF)	100 V					
	0603	0805	1206	1210	1808	1812
6,800			1.15±0.15			
8,200				0.85 ±0.10		1.25 ±0.20
10,000			1.25 ±0.20			
12,000						
15,000				1.25 ±0.20		0.85 ±0.10
18,000						
22,000						1.15±0.15
27,000						
33,000						
39,000						
47,000						

**NOTE**

1. Values in shaded cells indicate thickness class in mm.
2. Capacitance range < 10 pF is on request.

**CAPACITANCE RANGE & THICKNESS FOR NP0 200/250 V**

Table 3 For NP0 200/250 V sizes from 0603 to 1812

CAPACITANCE (pF)	200/250 V					
	0603	0805	1206	1210	1808	1812
10						
12						
15						
18						
22						
27						
33						
39						
47	0.8 ±0.10	0.6 ±0.10	0.6 ±0.10			
56						
68						
82						
100						
120						
150						
180						

Table 3 For NP0 200/250 V size from 0603 to 1812 (continued)

CAPACITANCE (pF)	200/250 V					
	0603	0805	1206	1210	1808	1812
220						
270						
330	0.8 ±0.10	0.85 ±0.10				
390			0.6 ±0.10			
470						
560		1.25 ±0.20				
680						
820		0.8 ±0.10				
1,000			0.85 ±0.10			
1,200				1.25 ±0.20		
1,500		1.25 ±0.20	1.15±0.15			
1,800			0.8 ±0.10			1.25 ±0.20
2,200				0.85 ±0.10		
2,700					1.25 ±0.20	
3,300			1.25 ±0.20	1.15±0.15		
3,900						0.85 ±0.10
4,700				1.25 ±0.20		1.15±0.15
5,600						
6,800						
8,200						
10,000						

**NOTE**

1. Values in shaded cells indicate thickness class in mm.
2. Capacitance range < 10 pF is on request.

**CAPACITANCE RANGE & THICKNESS FOR NP0 500 V**

Table 4 For NP0 500 V sizes from 0805 to 1812

CAPACITANCE (pF)	500 V				
	0805	1206	1210	1808	1812
10					
12					
15	0.6 ±0.10	0.6 ±0.10			
18					
22					
27					

Table 4 For NP0 500 V sizes from 0805 to 1812 (continued)

CAPACITANCE (pF)	500 V				
	0805	1206	1210	1808	1812
33					
39					
47					
56					
68	0.6 ±0.10	0.6 ±0.10			
82					
100					
120					
150					
180			0.85 ±0.10		
220					
270					
330	0.85 ±0.10				
390					
470		0.85 ±0.10			
560					
680					
820	1.25 ±0.20	1.15±0.15			
1,000					
1,200		0.8 ±0.10			1.25 ±0.20
1,500			1.15±0.15		
1,800		1.25 ±0.20		1.25 ±0.20	
2,200			1.25 ±0.20		
2,700					1.15±0.15
3,300					
3,900					
4,700					1.25 ±0.20
5,600					
6,800					
8,200					
10,000					

**NOTE**

1. Values in shaded cells indicate thickness class in mm.
2. Capacitance range < 10 pF is on request.



**CAPACITANCE RANGE & THICKNESS FOR X7R 100V**

Table 5 For X7R 100 V sizes from 0805 to 1812

CAPACITANCE (pF)	100 V 0603	0805	1206	1210	1808	1812
100						
150						
220						
330						
470						
680						
1,000	0.8 ±0.10					
1,500						
2,200		0.6 ±0.10	0.85 ±0.10			
3,300						
4,700						
6,800						
10,000						
15,000						
22,000		0.85 ±0.10				
33,000						
47,000		1.25 ±0.20				0.85 ±0.10
68,000				0.85 ±0.10	1.25 ±0.20	
100,000			1.15±0.15			
150,000				1.15±0.15		1.15±0.15
220,000				1.6 ±0.20		
330,000						
470,000						1.6 ±0.20
680,000						
1,000,000						

**NOTE**

1. Values in shaded cells indicate thickness class in mm.

**CAPACITANCE RANGE & THICKNESS FOR X7R 200/250 V**

Table 6 For X7R 200/250 V sizes from 0805 to 1812

CAPACITANCE (pF)	200/250 V				
	0805	1206	1210	1808	1812
100					
150					
220					
330					
470					
680					
1,000	0.85 ±0.10				
1,500					
2,200					
3,300		0.85 ±0.10			
4,700					
6,800					
10,000	1.25 ±0.20				
15,000	0.8 ±0.10		0.85 ±0.10		
22,000	1.25 ±0.20				
33,000		1.15±0.15	1.15±0.15	1.25 ±0.20	
47,000					
68,000		1.25 ±0.20			
100,000			1.25 ±0.20		1.15±0.15
150,000					
220,000					1.6 ±0.20
330,000					2.0 ±0.20
470,000					
680,000					
1,000,000					

**NOTE**

1. Values in shaded cells indicate thickness class in mm.

**CAPACITANCE RANGE & THICKNESS FOR X7R 500 V**

Table 7 For X7R 500 V sizes from 0805 to 1812

CAPACITANCE (pF)	500 V				
	0805	1206	1210	1808	1812
100					
150					
220					
330					
470					
680					
1,000	0.8 ±0.10				
1,500					
2,200		1.15±0.15			
3,300					
4,700			1.15±0.15		0.85 ±0.10
6,800					
10,000	1.25 ±0.20	1.25 ±0.20			1.15±0.15
15,000				1.25 ±0.20	
22,000			1.25 ±0.20		
33,000		1.6 ±0.20			
47,000					1.25 ±0.20
68,000					
100,000					1.6 ±0.20
150,000					
220,000					
330,000					
470,000					
680,000					
1,000,000					

**NOTE**

I. Values in shaded cells indicate thickness class in mm.

**THICKNESS CLASSES AND PACKING QUANTITY**

Table 8

DESCRIPTION	SIZE CODE	THICKNESS CLASSIFICATION (mm)	8 mm TAPE WIDTH/AMOUNT PER REEL				12 mm TAPE WIDTH /AMOUNT PER REEL
			Ø180 mm, 7"		Ø330 mm, 13"		Ø180 mm, 7" Blister
			Paper	Blister	Paper	Blister	
Mid/High voltage	0603	0.8 ±0.10	4,000	---	---	---	---
		0805	0.6 ±0.10	4,000	---	---	---
	0805	0.8 ±0.10	4,000	---	---	---	---
		0.85 ±0.1	4,000	---	---	---	---
		1.25 ±0.20	---	3,000	---	---	---
		1206	0.6 ±0.10	4,000	---	20,000	---
	1206	0.8 ±0.10	4,000	---	---	---	---
		0.85 ±0.10	4,000	---	15,000	---	---
		1.00 ±0.10	---	3,000	---	10,000	---
		1.15 ±0.15	---	3,000	---	10,000	---
		1.25 ±0.20	---	3,000	---	---	---
		1210	0.6 ±0.10	---	4,000	---	15,000
	1210	0.85 ±0.10	---	4,000	---	10,000	---
		1.15 ±0.15	---	3,000	---	10,000	---
		1.25 ±0.20	---	3,000	---	---	---
		1.6 ±0.20	---	2,000	---	---	---
	1808	1.15 ±0.15	---	---	---	---	1,500
		1.25 ±0.20	---	---	---	---	3,000
		1.35 ±0.15	---	---	---	---	1,000
		1.5 ±0.10	---	---	---	---	1,000
		1.6 ±0.20	---	---	---	---	2,000
		2.0 ±0.20	---	---	---	---	2,000
	1812	0.85 ±0.10	---	---	---	---	2,000
		1.15 ±0.15	---	---	---	---	1,500
		1.25 ±0.20	---	---	---	---	1,000
		1.35 ±0.15	---	---	---	---	1,000
		1.5 ±0.1	---	---	---	---	1,000
		1.6 ±0.2	---	---	---	---	1,000
		2.0 ±0.20	---	---	---	---	2,000

**ELECTRICAL CHARACTERISTICS**

**NP0/X7R DIELECTRIC CAPACITORS; NISN TERMINATIONS**

Unless otherwise stated all electrical values apply at an ambient temperature of 20±1 °C, an atmospheric pressure of 86 to 106 kPa, and a relative humidity of 63 to 67%.

Table 9

DESCRIPTION	VALUE
Capacitance range <sup>(1)</sup>	10 pF to 470 nF
Capacitance tolerance <sup>(1)</sup>	±5% and ±10%
Dissipation factor (D.F.) <sup>(1)</sup> :	
NP0	≤ 0.1%
X7R	≤ 2.5%
Insulation resistance after 1 minute at U <sub>r</sub> (DC)	R <sub>ins</sub> ≥ 10 GΩ or R <sub>ins</sub> × C ≥ 500 seconds whichever is less
Maximum capacitance change as a function of temperature (temperature characteristic/coefficient):	
NP0	±30 ppm/°C
X7R	±15%
Operating temperature range:	
NP0/X7R	-55 °C to +125 °C

**NOTE**

- 1. NP0: frequency = 1 MHz for C ≤ 1 nF, measuring at voltage 1 V<sub>rms</sub>; frequency = 1 KHz for C > 1 nF, measuring at voltage 1 V<sub>rms</sub>
- X7R: frequency = 1 KHz for C ≤ 10 μF, measuring at voltage 1 V<sub>rms</sub>

**TESTS AND REQUIREMENTS**

Table 10 Test condition, procedure and requirements

TEST	TEST METHOD	PROCEDURE	REQUIREMENTS
Mounting	IEC 60384-21/22 4.3	The capacitors may be mounted on printed-circuit boards or ceramic substrates	No visible damage
Visual inspection and dimension check	4.4	Any applicable method using × 10 magnification	In accordance with specification
Capacitance	4.5.1	NP0: f = 1 MHz for C ≤ 1 nF, measuring at voltage 1 V <sub>rms</sub> at 20 °C; f = 1 KHz for C > 1 nF, measuring at voltage 1 V <sub>rms</sub> at 20 °C X7R: f = 1 KHz for C ≤ 10 μF, measuring at voltage 1 V <sub>rms</sub> at 20 °C	Within specified tolerance
Dissipation factor (D.F.)	4.5.2	NP0: f = 1 MHz for C ≤ 1 nF, measuring at voltage 1 V <sub>rms</sub> at 20 °C; f = 1 KHz for C > 1 nF, measuring at voltage 1 V <sub>rms</sub> at 20 °C X7R: f = 1 KHz for C ≤ 10 μF, measuring at voltage 1 V <sub>rms</sub> at 20 °C	In accordance with specification
Insulation resistance	4.5.3	At U <sub>r</sub> (DC) for 1 minute	In accordance with specification
Voltage proof	4.5.4.2	Test voltage (DC) applied for 1 minute U <sub>r</sub> ≤ 100 V: 2.5 × U <sub>r</sub> applied to NP0/X7R series 100 V < U <sub>r</sub> ≤ 200 V: 1.5 × U <sub>r</sub> + 100 V applied to NP0/X7R series 200 V < U <sub>r</sub> ≤ 500 V: 1.3 × U <sub>r</sub> + 100 V applied to NP0/X7R series U <sub>r</sub> > 500 V: 1.3 × U <sub>r</sub> applied to NP0/X7R series I: 7.5 mA	No breakdown or flashover
Temperature characteristic	4.6	Between minimum and maximum temperature	NP0: ΔC/C: 30 ppm/°C X7R: ΔC/C: 15%
Adhesion	4.15	A force applied for 10 seconds to the line joining the terminations and in a plane parallel to the substrate for size ≥ 0603: a force of 5 N applied for size 0402: a force of 2.5 N applied	No visible damage

Table 10 Test condition, procedure and requirements (continued)

TEST	TEST METHOD	PROCEDURE	REQUIREMENTS
Bond strength of plating on end face	IEC 60384-21/22 4.8	Mounting in accordance with IEC 60384-22 paragraph 4.3  Conditions: bending 1 mm at a rate of 1 mm/s, radius jig 340 mm	No visible damage  NP0: $\Delta C/C_i \leq 1\%$ or 0.5 pF whichever is greater X7R: $\Delta C/C_i \leq 10\%$
Resistance to soldering heat	4.9	Precondition: 150 +0/-10 °C for 1 hour, then keep for 24 ± 1 hours at room temperature Preheating: for size ≤ 1206: 120 to 150 °C for 1 minute Preheating: for size > 1206: 100 to 120 °C for 1 minute and 170 to 200 °C for 1 minute Solder bath temperature: 260 ± 5 °C Dipping time: 10 ± 0.5 seconds Recovery time: 24 ± 2 hours.	The termination shall be well tinned NP0: $\Delta C/C_i \leq 0.5\%$ or 0.5 pF whichever is greater X7R: $\Delta C/C_i \leq 10\%$  D.F.: within initial specified value $R_{ins}$ : within initial specified value
Solderability	4.10	Unmounted chips completely immersed in a solder bath at 235 ± 5 °C Dipping time: 2 ± 0.5 seconds Depth of immersion: 10 mm	The termination shall be well tinned.
Rapid change of temperature	4.11	Preconditioning; 150 +0/-10 °C for 1 hour, then keep for 24 ± 1 hours at room temperature <hr/> 5 cycles with following detail: 30 minutes at lower category temperature; 30 minutes at upper category temperature <hr/> Recovery time 24 ± 2 hours.	No visual damage NP0: $\Delta C/C_i \leq 1\%$ or 1 pF whichever is greater X7R: $\Delta C/C_i \leq 15\%$ D.F.: within initial specified value $R_{ins}$ : within initial specified value
Damp heat, with $U_r$ load	4.13	Initial measurements; after 150 +0/-10 °C for 1 hour, then keep for 24 ± 1 hours at room temperature Duration and conditions: 500 ± 12 hours at 40 ± 2 °C; 90 to 95% RH; $U_r$ applied Final measurement: perform a heat treatment at 150 +0/-10 °C for 1 hour, final measurements shall be carried out 24 ± 1 hours after recovery at room temperature without load.	NP0: $\Delta C/C_i \leq 2\%$ or 1 pF whichever is greater X7R: $\Delta C/C_i \leq 15\%$  NP0: D.F.: 2 × initial value max. X7R ≥ 100 V: D.F. ≤ 5%  NP0: $R_{ins} \geq 2,500 M\Omega$ or $R_{ins} \times C_r \geq 25$ seconds, whichever is less X7R: $R_{ins} \geq 500 M\Omega$ or $R_{ins} \times C_r \geq 25$ seconds, whichever is less

Table 10 Test condition, procedure and requirements (continued)

TEST	TEST METHOD	PROCEDURE	REQUIREMENTS
Endurance	IEC 60384-21/22 4.14	<p>Preconditioning; Initial measurements; after 150 +0/-10 °C for 1 hour, then keep for 24 ± 1 hours at room temperature</p> <p>Duration and conditions: 1,000 ± 12 hours at upper category temperature with 1.5 × U<sub>r</sub> voltage applied</p> <p>Final measurement: perform a heat treatment at 150 +0/-10 °C for 1 hour; final measurements shall be carried out 24 ± 1 hours after recovery at room temperature without load.</p>	<p>NP0: <math>\Delta C/C_i \leq 2\%</math> or 1 pF whichever is greater</p> <p>X7R: <math>\Delta C/C_i \leq 15\%</math></p> <p>NP0: D.F.: 2 × initial value max.</p> <p>X7R ≥ 100 V: D.F. ≤ 5%</p> <p>NP0: <math>R_{ins} \geq 4,000 M\Omega</math> or <math>R_{ins} \times C_r \geq 40</math> seconds, whichever is less</p> <p>X7R: <math>R_{ins} \geq 1,000 M\Omega</math> or <math>R_{ins} \times C_r \geq 50</math> seconds, whichever is less</p>



REVISION HISTORY

REVISION	DATE	CHANGE NOTIFICATION	DESCRIPTION
Version 0	Sep 08, 2005	-	- New