

Polymer PTC Resettable Fuse: KRL Series

120V Lead Type



■ Features

1. RoHS compliant
2. Radial leaded devices
3. Current ratings from 0.10A ~ 3.75A
4. Maximum operating voltage: 120 V_{AC}
5. Operating temperature range : -40 ~ +85°C
6. Agency Approval: UL/cUL/TUV

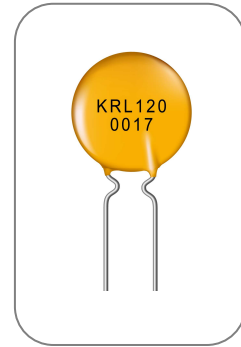

■ Recommended Applications

1. Motors, fans and blowers
2. Power supplies
3. Transformers
4. Industrial controllers

■ Part Number Code

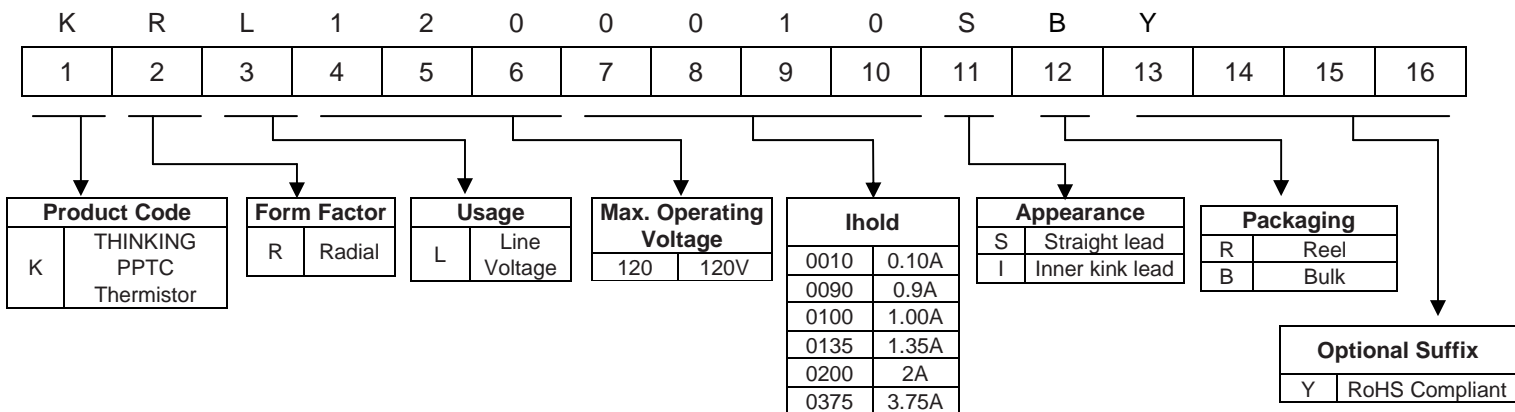

Polymer PTC Resettable Fuse: KRL Series

120V Lead Type



■ Structure and Dimensions

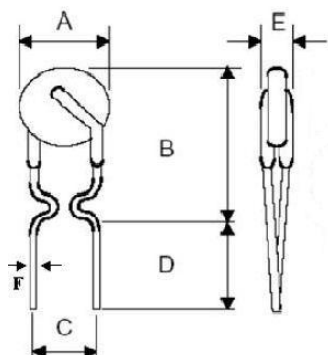

Figure 1

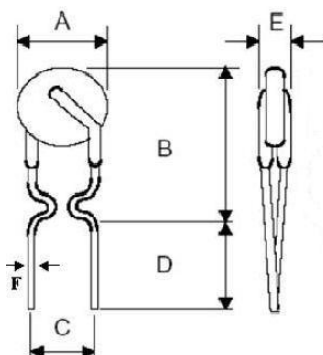

Figure 2

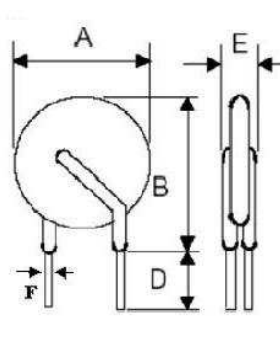

Figure 3

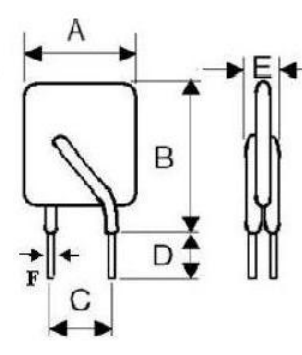

Figure 4

(Unit: mm)

Part No.	A	B	C	D	E	F	Figure
	Max.	Max.	Typ.	Min.	Max.	Typ.	
KRL1200010	7.9	13.0	5.1	7.6	3.8	0.51	1
KRL1200017	7.9	13.0	5.1	7.6	3.8	0.51	1
KRL1200020	7.9	13.0	5.1	7.6	3.8	0.65	2
KRL1200025	7.9	13.0	5.1	7.6	3.8	0.65	2
KRL1200030	7.9	13.0	5.1	7.6	3.8	0.65	2
KRL1200040	8.2	14.2	5.1	7.6	3.8	0.65	2
KRL1200050	9.2	14.9	5.1	7.6	3.8	0.65	2
KRL1200065	9.7	14.9	5.1	7.6	3.8	0.65	2
KRL1200070	10.6	15.5	5.1	7.6	3.8	0.65	2
KRL1200075	10.9	17.0	5.1	7.6	4.1	0.81	4
KRL1200090	11.9	15.9	5.1	7.6	3.8	0.65	2
KRL1200100	11.5	20.1	5.1	7.6	4.1	0.81	4
KRL1200110	13.3	18.3	5.1	7.6	4.1	0.81	3
KRL1200125	14.0	21.7	5.1	7.6	4.1	0.81	4
KRL1200130	15.5	20.6	5.1	7.6	4.1	0.81	3
KRL1200135	16.3	21.7	5.1	7.6	4.1	0.81	4
KRL1200160	17.5	22.5	5.1	7.6	4.1	0.81	3
KRL1200185	19.9	24.9	5.1	7.6	4.1	0.81	3
KRL1200200	23.5	27.9	10.2	7.6	4.1	0.81	4
KRL1200250	22.5	27.5	10.2	7.6	4.1	0.81	3
KRL1200300	25.5	30.0	10.2	7.6	4.1	0.81	3
KRL1200375	29.5	34.0	10.2	7.6	4.1	0.81	3

Polymer PTC Resettable Fuse: KRL Series

120V Lead Type



■ Electrical Characteristics(@23°C)

Part No.	Vmax.	Imax.	Ihold	Itrip	Pd (Typ.)	Max. Time to Trip		Resistance		Agency Approval	
						Current	Time	Initial (Ri Min.)	Post trip (R1 Max.)	UL/cUL	TUV
	(V _{AC})	(A)	(A)	(A)	(W)	(A)	(Sec.)	(Ω)	(Ω)		
KRL1200010	120	2.0	0.10	0.20	0.84	0.50	10.0	3.00	7.50	√	√
KRL1200017	120	2.0	0.17	0.34	0.84	0.85	10.0	2.00	7.00	√	√
KRL1200020	120	2.0	0.20	0.40	1.08	1.00	9.0	1.83	4.40	√	√
KRL1200025	120	3.0	0.25	0.50	1.08	1.25	7.5	1.25	3.00	√	√
KRL1200030	120	3.0	0.30	0.60	1.44	1.50	8.5	0.88	2.10	√	√
KRL1200040	120	3.0	0.40	0.80	1.44	2.00	6.5	0.55	1.29	√	√
KRL1200050	120	3.0	0.50	1.00	1.56	2.50	6.0	0.50	1.17	√	√
KRL1200065	120	5.0	0.65	1.30	1.68	3.25	5.7	0.31	0.72	√	√
KRL1200070	120	5.0	0.75	1.50	1.80	3.75	6.3	0.25	0.60	√	√
KRL1200075	120	7.5	0.75	1.50	2.64	3.75	15.0	0.25	0.69	√	√
KRL1200090	120	5.0	0.90	1.80	1.80	4.50	7.20	0.20	0.47	√	√
KRL1200100	120	10.0	1.00	2.00	2.64	5.00	15.0	0.18	0.47	√	√
KRL1200110	120	8.0	1.10	2.20	2.28	5.50	8.2	0.15	0.38	√	√
KRL1200125	120	12.5	1.25	2.50	2.88	6.25	20.0	0.11	0.33	√	√
KRL1200130	120	10.0	1.35	2.70	2.64	6.75	9.6	0.12	0.30	√	√
KRL1200135	120	13.5	1.35	2.70	3.12	6.75	20.0	0.11	0.30	√	√
KRL1200160	120	12.0	1.60	3.20	3.12	8.00	11.4	0.09	0.22	√	√
KRL1200185	120	12.0	1.85	3.70	3.36	9.25	12.6	0.08	0.19	√	√
KRL1200200	120	20.0	2.00	4.20	4.32	10.00	36.0	0.08	0.21	√	√
KRL1200250	120	15.0	2.50	5.00	4.44	12.50	15.6	0.05	0.13	√	√
KRL1200300	120	17.0	3.00	6.00	4.56	15.00	19.8	0.04	0.10	√	√
KRL1200375	120	20.0	3.75	7.50	4.80	18.75	24.0	0.03	0.08	√	√

Note: UL&cUL File No. E138827

TUV File No. R50166228

Polymer PTC Resettable Fuse: KRL Series

120V Lead Type



■ Typical Time to Trip Curves at 23°C

- A=KRL1200010
- B= KRL1200017
- C= KRL1200020
- D= KRL1200025
- E= KRL1200030
- F= KRL1200040
- G= KRL1200050
- H= KRL1200065
- I = KRL1200070
- J= KRL1200090
- K= KRL1200110
- L= KRL1200130
- M= KRL1200160
- N= KRL1200185
- O= KRL1200250
- P= KRL1200300
- Q= KRL1200375

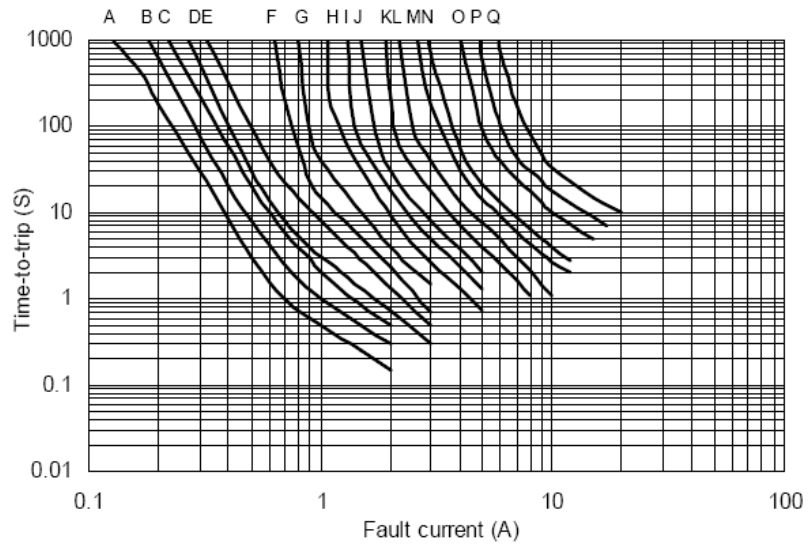

- R= KRL1200075
- S= KRL1200100
- T= KRL1200125
- U= KRL1200135
- V= KRL1200200

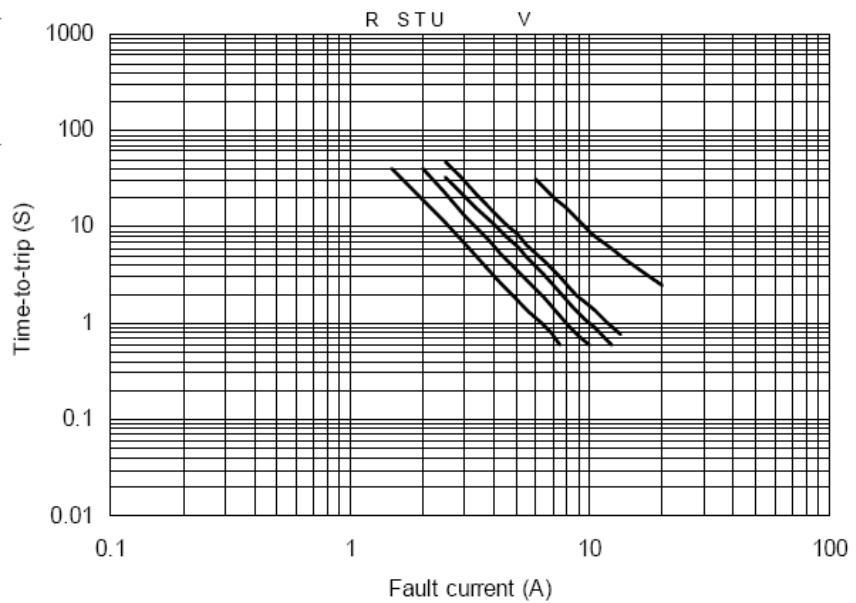

■ Derating Curve

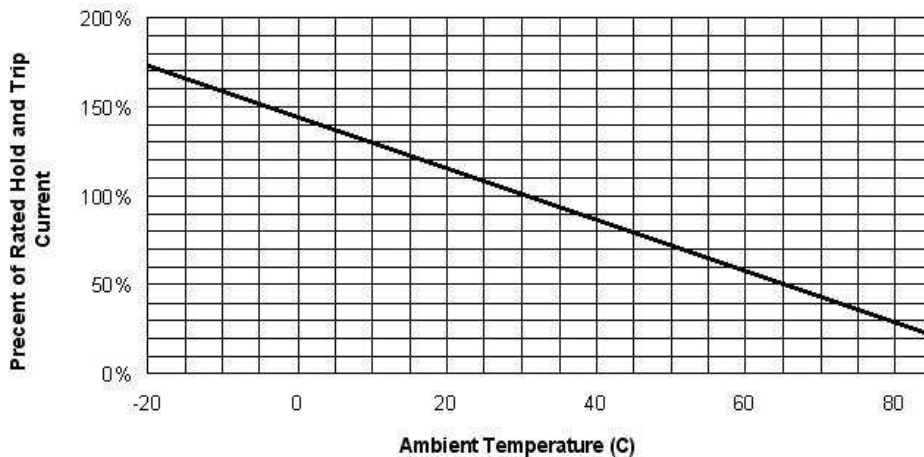

Polymer PTC Resettable Fuse: KRL Series

120V Lead Type



■ Packaging

● Tape & Reel Specification

See table below and Fig. 1~5 for details

Description	EIA Mark	Dimensions (mm)	Tolerance (mm)
Sprocket hole pitch	P ₀	12.7	±0.3
Ordinate to adjacent component lead KRL1200010-KRL1200100	P ₁	3.6	±1.0
Ordinate to adjacent component lead KRL1200110-KRL1200185		3.45	
Ordinate to adjacent component lead KRL1200200-KRL1200300		7.3	
Device pitch KRL1200010-KRL1200100	P	12.7	±1.0
Device pitch KRL1200110-KRL1200250		25.4	
Device pitch KRL1200300~KRL1200375		38.1	
Carrier tape width	W	18.0	±1.0
Top distance between tape edges	W ₀	3.0	Max
Hold-down tape width	W ₁	12.0	±1.0
Lead spacing	C	See "Structure and Dimensions"	--
Abscissa to top KRL1200010 to KRL1200070	H ₁	32.2	max
Abscissa to top KRL1200075 to KRL1200375		47.5	
Abscissa to plane (straight lead)	H	18.0	+2/-0
Abscissa to plane (kinked lead)	H ₀	16.0	±0.5
Sprocket hole position	W ₂	9	+0.75/-0.5
Sprocket hole diameter	D ₀	4.0	±0.2
Lead protrusion	L ₁	1.0	Max.
Tape thickness	t	0.9	Max.
Body tape plane deviation	△p	0	±1.3
Body lateral deviation	△h	0	±1.0
Reel width	W ₃	56	Max.
Reel diameter		340	±10.0
Arbor hold diameter	n ₀	31	±1
Core diameter	n	80	Min.

Polymer PTC Resettable Fuse: KRL Series

120V Lead Type



● Taping Specification

Figure 1.

KRL1200010 to KRL1200070, KRL1200090, KRL1200110, KRL1200130, KRL1200160, KRL1200185

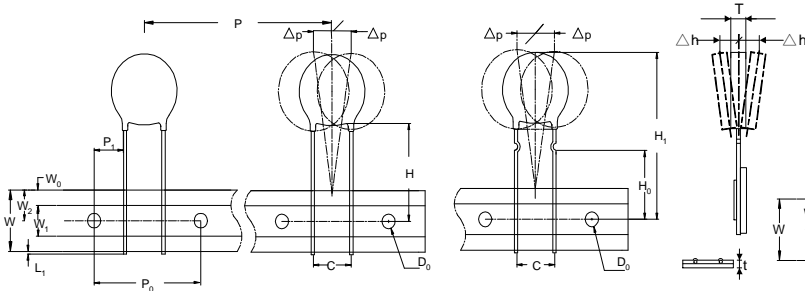

Figure 2.

KRL1200075, KRL1200100, KRL1200125, KRL1200135

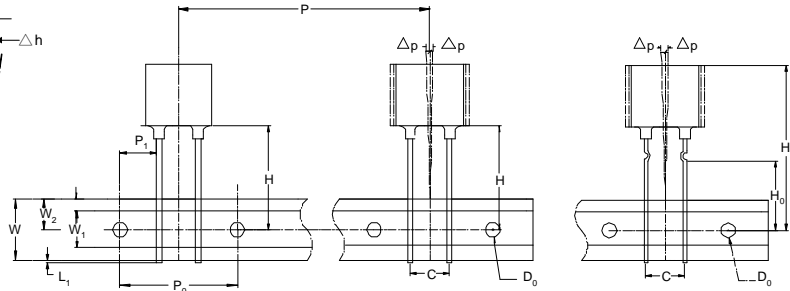

Figure 3.

KRL1200200

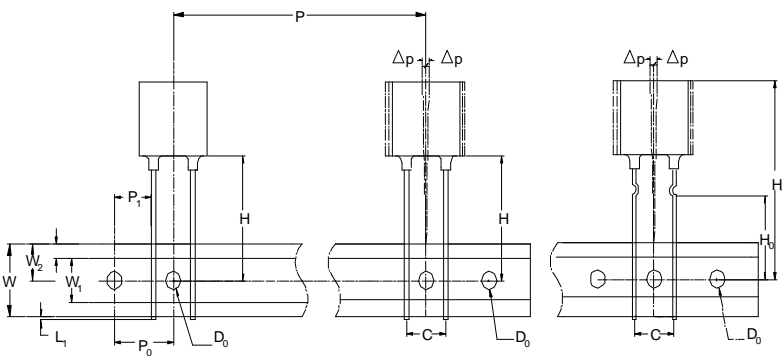
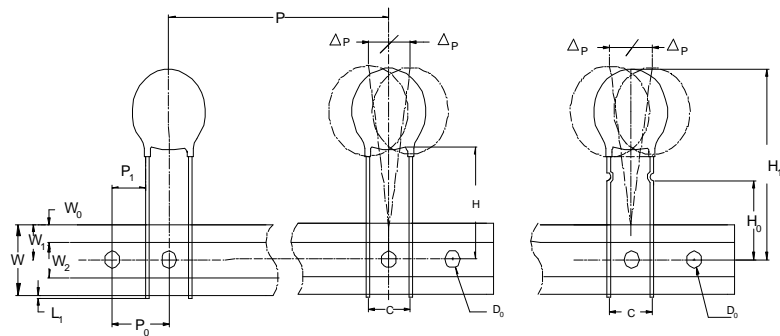

Figure 4.

KRL1200250, KRL1200300, KRL1200375



● Reel Specification

Figure 5.

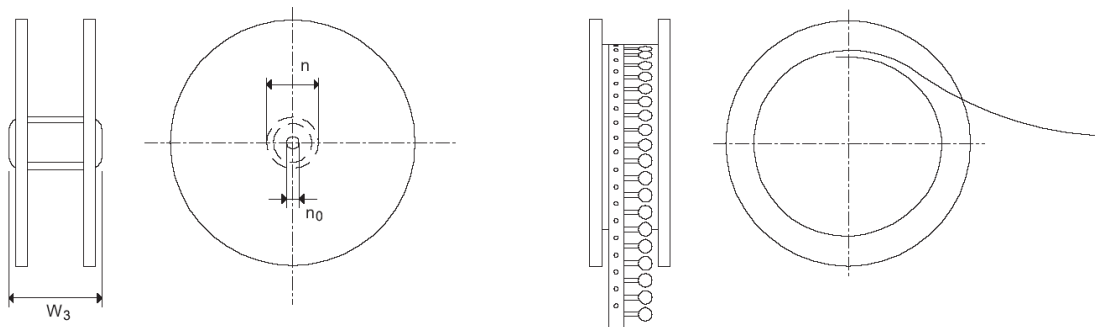

Polymer PTC Resettable Fuse: KRL Series

120V Lead Type



■ Quantity

● Bulk Packing

Part No.	Pcs/ Bag
KRL1200010-KRL1200050	500
KRL1200065-KRL1200110	300
KRL1200125- KRL1200160	200
KRL1200185- KRL1200375	100

● Reel Packing

Part No.	Pcs/ Reel
KRL1200010-KRL1200050	2000
KRL1200065-KRL1200375	1500

■ Storage Conditions of Products

● Storage Conditions :

1. Storage Temperature: $-10^{\circ}\text{C} \sim +40^{\circ}\text{C}$
2. Relative Humidity: $\leq 75\% \text{RH}$
3. Thermistors must be kept away from sunlight and stored in a non-corrosive atmosphere.

● Period of Storage: 1 year