

X20C16

PIN DESCRIPTIONS

Addresses (A₀–A₁₀)

The Address inputs select an 8-bit memory location during a read or write operation.

Chip Enable (\overline{CE})

The Chip Enable input must be LOW to enable all read/write operations. When \overline{CE} is HIGH, power consumption is reduced.

Output Enable (\overline{OE})

The Output Enable input controls the data output buffers and is used to initiate read and recall operations. Output Enable LOW disables a store operation regardless of the state of \overline{CE} , \overline{WE} , or \overline{NE} .

Data In/Data Out (I/O₀–I/O₇)

Data is written to or read from the X20C16 through the I/O pins. The I/O pins are placed in the high impedance state when either \overline{CE} or \overline{OE} is HIGH or when \overline{NE} is LOW.

Write Enable (\overline{WE})

The Write Enable input controls the writing of data to the static RAM.

Nonvolatile Enable (\overline{NE})

The Nonvolatile Enable input controls the recall function to the E²PROM array.

AUTOSTORE Output (\overline{AS})

\overline{AS} is an open drain output which, when asserted indicates V_{CC} has fallen below the AUTOSTORE threshold (V_{ASTH}). \overline{AS} may be wire-ORed with multiple open drain outputs and used as an interrupt input to a microcontroller.

PIN NAMES

Symbol	Description
A ₀ –A ₁₀	Address Inputs
I/O ₀ –I/O ₇	Data Input/Output
\overline{WE}	Write Enable
\overline{CE}	Chip Enable
\overline{OE}	Output Enable
\overline{NE}	Nonvolatile Enable
\overline{AS}	AUTOSTORE Output
V _{CC}	+5V
V _{SS}	Ground
NC	No Connect

3826 PGM T01

FUNCTIONAL DIAGRAM

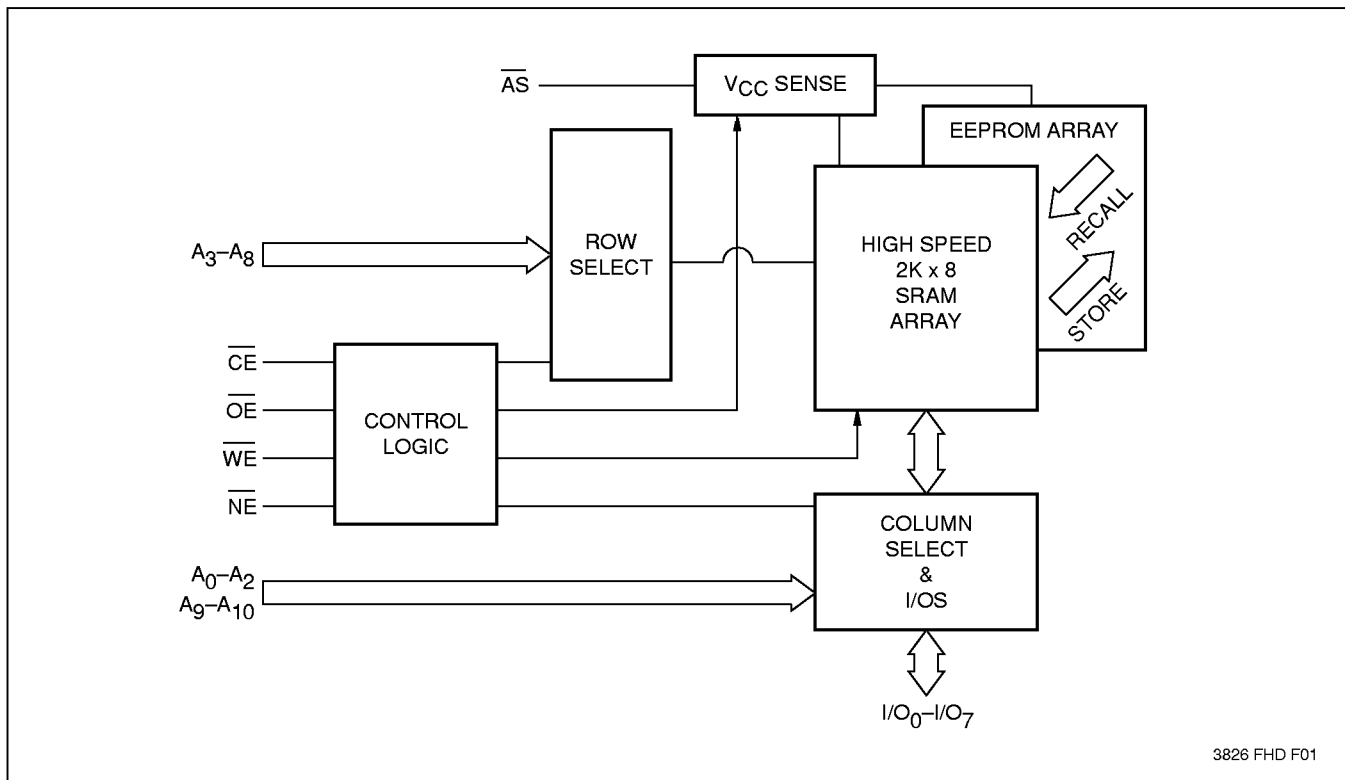

3826 FHD F01

X20C16

DEVICE OPERATION

The \overline{CE} , \overline{OE} , \overline{WE} , and \overline{NE} inputs control the X20C16 operation. The X20C16 byte-wide NOVRAM uses a 2-line control architecture to eliminate bus contention in a system environment. The I/O bus will be in a high impedance state when either \overline{OE} or \overline{CE} is HIGH, or when \overline{NE} is LOW.

RAM Operations

RAM read and write operations are performed as they would be with any static RAM. A read operation requires \overline{CE} and \overline{OE} to be LOW with \overline{WE} and \overline{NE} HIGH. A write operation requires \overline{CE} and \overline{WE} to be LOW with \overline{NE} HIGH. There is no limit to the number of read or write operations performed to the RAM portion of the X20C16.

Memory Transfer Operations

There are two memory transfer operations: a recall operation whereby the data stored in the E²PROM array is transferred to the RAM array; and a store operation which causes the entire contents of the RAM array to be stored in the E²PROM array.

Recall operations are performed automatically upon power-up and under host system control when \overline{NE} , \overline{OE} and \overline{CE} are LOW and \overline{WE} is HIGH. The recall operation takes a maximum of 5 μ s.

SDP (Software Data Protection)

There are two methods of initiating a store operation. The first is the software store command. This command takes the place of the hardware store employed on the X20C04. This command is issued by entering into the special command mode: \overline{NE} , \overline{CE} , and \overline{WE} strobe LOW while at the same time a specific address and data combination is sent to the device. This is a three step operation: the first address/data combination is 555[H]/AA[H]; the second combination is 2AA[H]/55[H]; and the final command combination is 555[H]/33[H]. This sequence of pseudo write operations will immediately initiate a store operation. Refer to the software command timing diagrams for details on set and hold times for the various signals.

The second method of storing data is with the AUTOSTORE command. When enabled, data is auto-

matically stored from the RAM into the E²PROM array whenever V_{CC} falls below the preset Autostore threshold. This feature is enabled by performing the first two steps for the software store with the command combination being 555[H]/CC[H].

The AUTOSTORE feature is disabled by issuing the three step command sequence with the command combination being 555[H]/CD[H]. The AUTOSTORE feature will also be reset if V_{CC} falls below the power-up reset threshold (approximately 3.5V) and is then raised back into the operation range.

Write Protection





The X20C16 supports two methods of protecting the nonvolatile data.

—If after power-up the AUTOSTORE feature is not enabled, no AUTOSTORE can occur.

— V_{CC} Sense – All functions are inhibited when V_{CC} is $\leq 3.0V$ typical.

SYMBOL TABLE

The following symbol table provides a key to understanding the conventions used in the device timing diagrams. The diagrams should be used in conjunction with the device timing specifications to determine actual device operation and performance, as well as device suitability for user's application.

WAVEFORM	INPUTS	OUTPUTS
	Must be steady	Will be steady
	May change from LOW to HIGH	Will change from LOW to HIGH
	May change from HIGH to LOW	Will change from HIGH to LOW
	Don't Care: Changes Allowed	Changing: State Not Known
	N/A	Center Line is High Impedance

X20C16

ABSOLUTE MAXIMUM RATINGS*

Temperature under Bias -65°C to +135°C
 Storage Temperature -65°C to +150°C
 Voltage on any Pin with
 Respect to V_{SS} -1V to +7V
 D.C. Output Current 10mA
 Lead Temperature (Soldering, 10 seconds)..... 300°C

*COMMENT

Stresses above those listed under “Absolute Maximum Ratings” may cause permanent damage to the device. This is a stress rating only and the functional operation of the device at these or any conditions other than those indicated in the operational sections of this specification is not implied. Exposure to absolute maximum rating conditions for extended periods may affect device reliability.

RECOMMENDED OPERATING CONDITIONS

Temperature	Min.	Max.
Commercial	0°C	+70°C
Industrial	-40°C	+85°C
Military	-55°C	+125°C

3826 PGM T02.1

Supply Voltage	Limits
X20C16	5V ±10%

3826 PGM T03.1

D.C. OPERATING CHARACTERISTICS (Over recommended operating conditions unless otherwise specified.)

Symbol	Parameter	Limits			Test Conditions
		Min.	Max.	Units	
I _{CC1}	V _{CC} Current (Active)		100	mA	$\overline{NE} = \overline{WE} = V_{IH}, \overline{CE} = \overline{OE} = V_{IL}$ Address Inputs = 0.4V/2.4V Levels @ f = 20MHz All I/Os = Open
I _{CC2}	V _{CC} Current During Store		5	mA	All Inputs = V _{IH}
I _{CC3} (2)	V _{CC} Current During AUTOSTORE		2.5	mA	All I/Os = Open
I _{SB1}	V _{CC} Standby Current (TTL Input)		10	mA	$\overline{CE} = V_{IH}$, All Other Inputs = V _{IH} All I/Os = Open
I _{SB2}	V _{CC} Standby Current (CMOS Input)		250	µA	All Inputs = V _{CC} - 0.3V All I/Os = Open
I _{LI}	Input Leakage Current		10	µA	V _{IN} = V _{SS} to V _{CC}
I _{LO}	Output Leakage Current		10	µA	V _{OUT} = V _{SS} to V _{CC} , $\overline{CE} = V_{IH}$
V _{IL} (1)	Input LOW Voltage	-1	0.8	V	
V _{IH} (1)	Input HIGH Voltage	2	V _{CC} + 0.5	V	
V _{OL}	Output LOW Voltage		0.4	V	I _{OL} = 4mA
V _{OLAS}	AUTOSTORE Output		0.4	V	I _{OLAS} = 1mA
V _{OH}	Output HIGH Voltage	2.4		V	I _{OH} = -4mA

3826 PGM T04.3

POWER-UP TIMING

Symbol	Parameter	Max.	Units
t _{PUR} (2)	Power-Up to RAM Operation	100	µs
t _{PJW} (2)	Power-Up to Nonvolatile Operation	5	ms

3826 PGM T05

CAPACITANCE T_A = +25°C, f = 1MHz, V_{CC} = 5V.

Symbol	Test	Max.	Units	Conditions
C _{I/O} (2)	Input/Output Capacitance	10	pF	V _{I/O} = 0V
C _{IN} (2)	Input Capacitance	6	pF	V _{IN} = 0V

3826 PGM T06.1

Notes: (1) V_{IL} min. and V_{IH} max. are for reference only and are not tested.
 (2) This parameter is periodically sampled and not 100% tested.

X20C16

ENDURANCE AND DATA RETENTION

Parameter	Min.	Units
Endurance	100,000	Data Changes Per Bit
Store Cycles	1,000,000	Store Cycles
Data Retention	100	Years

3826 PGM T07.1

MODE SELECTION

\overline{CE}	\overline{WE}	\overline{NE}	\overline{OE}	Mode	I/O	Power
H	X	X	X	Not Selected	Output High Z	Standby
L	H	H	L	Read RAM	Output Data	Active
L	L	H	H	Write "1" RAM	Input Data High	Active
L	L	H	H	Write "0" RAM	Input Data Low	Active
L	H	L	L	Array Recall	Output High Z	Active
L	L	L	H	Software Command	Input Data	Active
L	H	H	H	Output Disabled	Output High Z	Active
L	L	L	L	Not Allowed	Output High Z	Active
L	H	L	H	No Operation	Output High Z	Active

3826 PGM T09

EQUIVALENT A.C. LOAD CIRCUIT

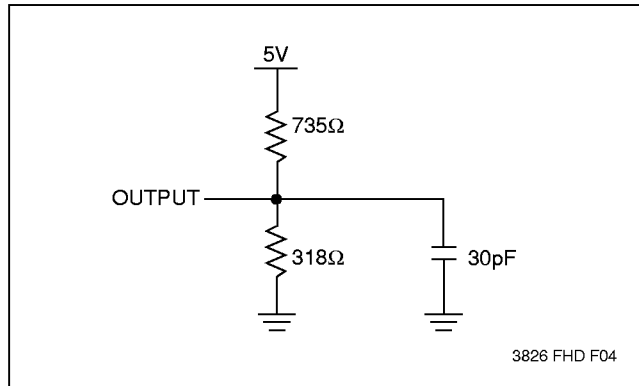

3826 FHD F04

A.C. CONDITIONS OF TEST

Input Pulse Levels	0V to 3V
Input Rise and Fall Times	5ns
Input and Output Timing Levels	1.5V

3826 PGM T08.1

X20C16

A.C. CHARACTERISTICS (Over the recommended operating conditions unless otherwise specified)

Read Cycle Limits

Symbol	Parameter	X20C16-35 -40 to +85°C		X20C16-45		X20C16-55		Units
		Min.	Max.	Min.	Max.	Min.	Max.	
t_{RC}	Read Cycle Time	35		45		55		ns
t_{CE}	Chip Enable Access Time		35		45		55	ns
t_{AA}	Address Access Time		35		45		55	ns
t_{OE}	Output Enable Access Time		20		25		30	ns
$t_{LZ}^{(3)}$	Chip Enable to Output in Low Z	0		0		0		ns
$t_{OLZ}^{(3)}$	Output Enable to Output in Low Z	0		0		0		ns
$t_{HZ}^{(3)}$	Chip Disable to Output in High Z	0	15	0	20	0	25	ns
$t_{OHZ}^{(3)}$	Output Disable to Output in High Z	0	15	0	20	0	25	ns
t_{OH}	Output Hold From Address Change	0		0		0		ns

3826 PGM T10

Read Cycle

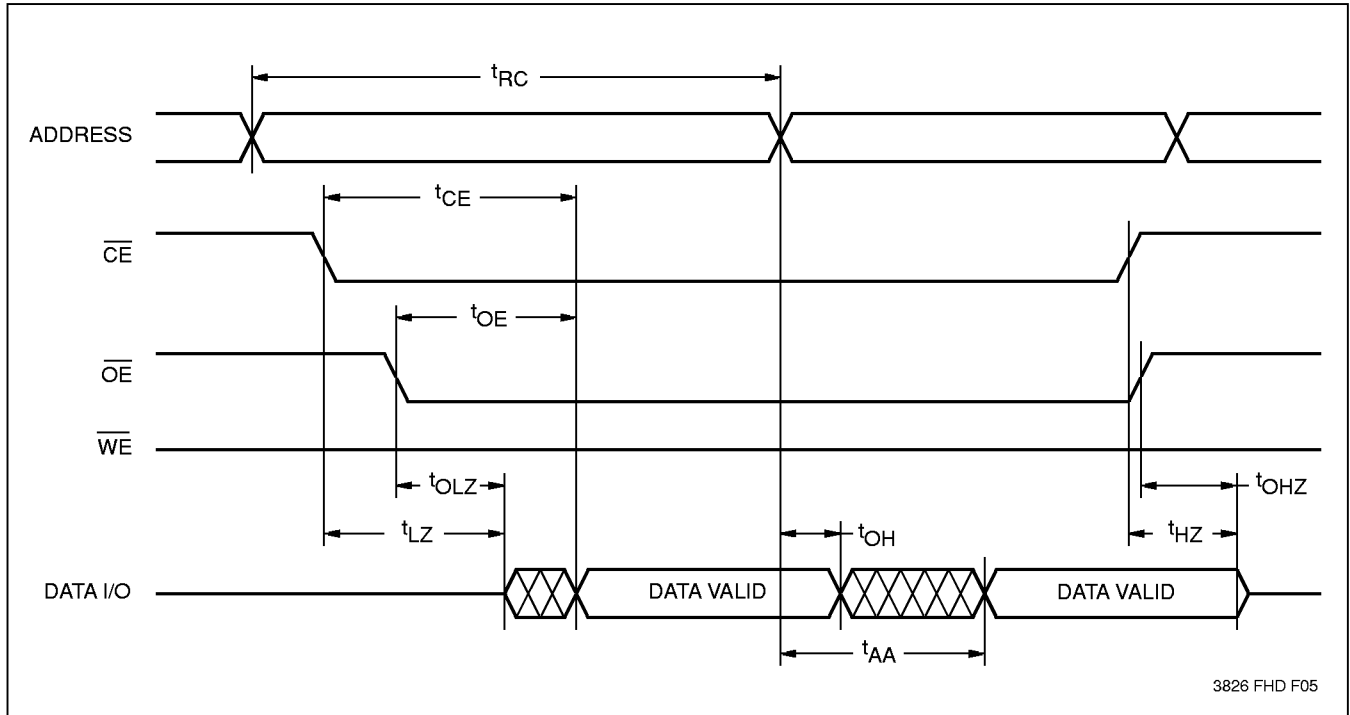

3826 FHD F05

Note: (3) t_{LZ} min., t_{HZ} , t_{OLZ} min., and t_{OHZ} are periodically sampled and not 100% tested. t_{HZ} max. and t_{OHZ} max. are measured, with $C_L = 5\text{pF}$, from the point when \overline{CE} or \overline{OE} return HIGH (whichever occurs first) to the time when the output are no longer driven.

X20C16

Write Cycle Limits

Symbol	Parameter	X20C16-35		X20C16-45		X20C16-55		Units
		Min.	Max.	Min.	Max.	Min.	Max.	
t_{WC}	Write Cycle Time	35		45		55		ns
t_{CW}	Chip Enable to End of Write Input	30		35		40		ns
t_{AS}	Address Setup Time	0		0		0		ns
t_{WP}	Write Pulse Width	30		35		40		ns
t_{WR}	Write Recovery Time	0		0		0		ns
t_{DW}	Data Setup to End of Write	15		20		25		ns
t_{DH}	Data Hold Time	3		3		3		ns
$t_{WZ}^{(4)}$	Write Enable to Output in High Z		15		20		25	ns
$t_{OW}^{(4)}$	Output Active from End of Write	5		5		5		ns
$t_{OZ}^{(4)}$	Output Enable to Output in High Z		15		20		25	ns

3826 PGM T11

\overline{WE} Controlled Write Cycle

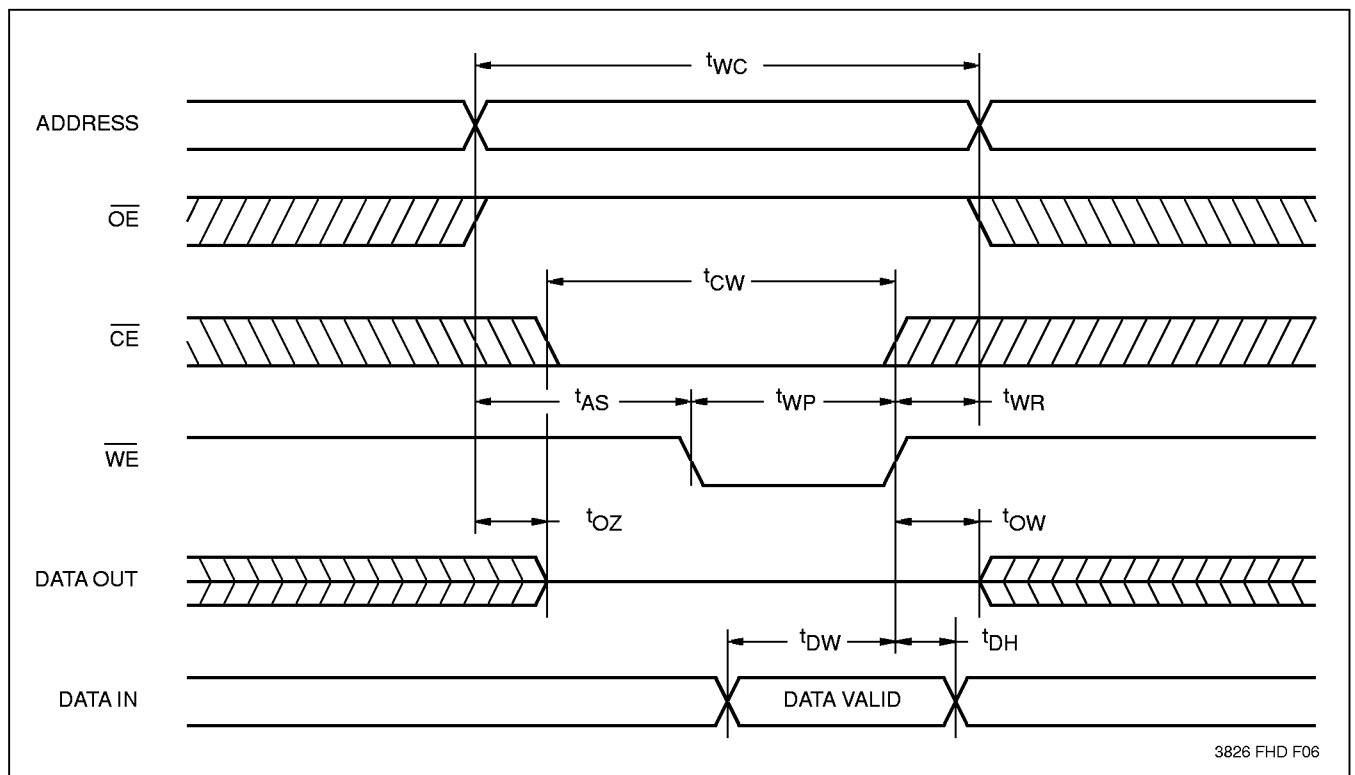

3826 FHD F06

Note: (4) t_{WZ} , t_{OW} , t_{OZ} are periodically sampled and not 100% tested.

X20C16

\overline{CE} Controlled Write Cycle

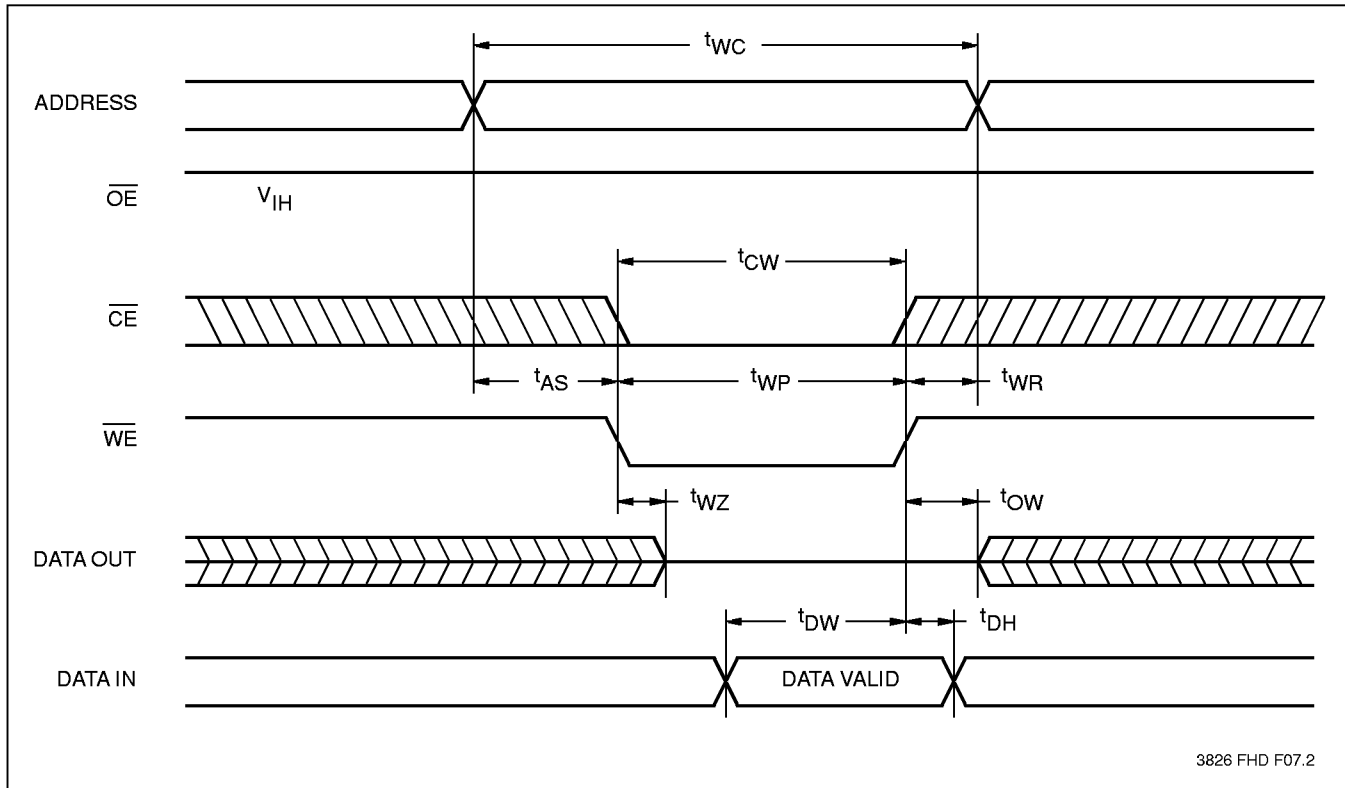

X20C16

ARRAY RECALL CYCLE LIMITS

Symbol	Parameter	X20C16-35		X20C16-45		X20C16-55		Units
		Min.	Max.	Min.	Max.	Min.	Max.	
t_{RCC}	Array Recall Cycle Time		10		10		10	μs
$t_{RCP}^{(5)}$	Recall Pulse Width to Initiate Recall	0.6	1000	40	1000	50	1000	ns
t_{RWE}	\overline{WE} Setup Time to \overline{NE}	0		0		0		ns

3826 PGM T13

Array Recall Cycle

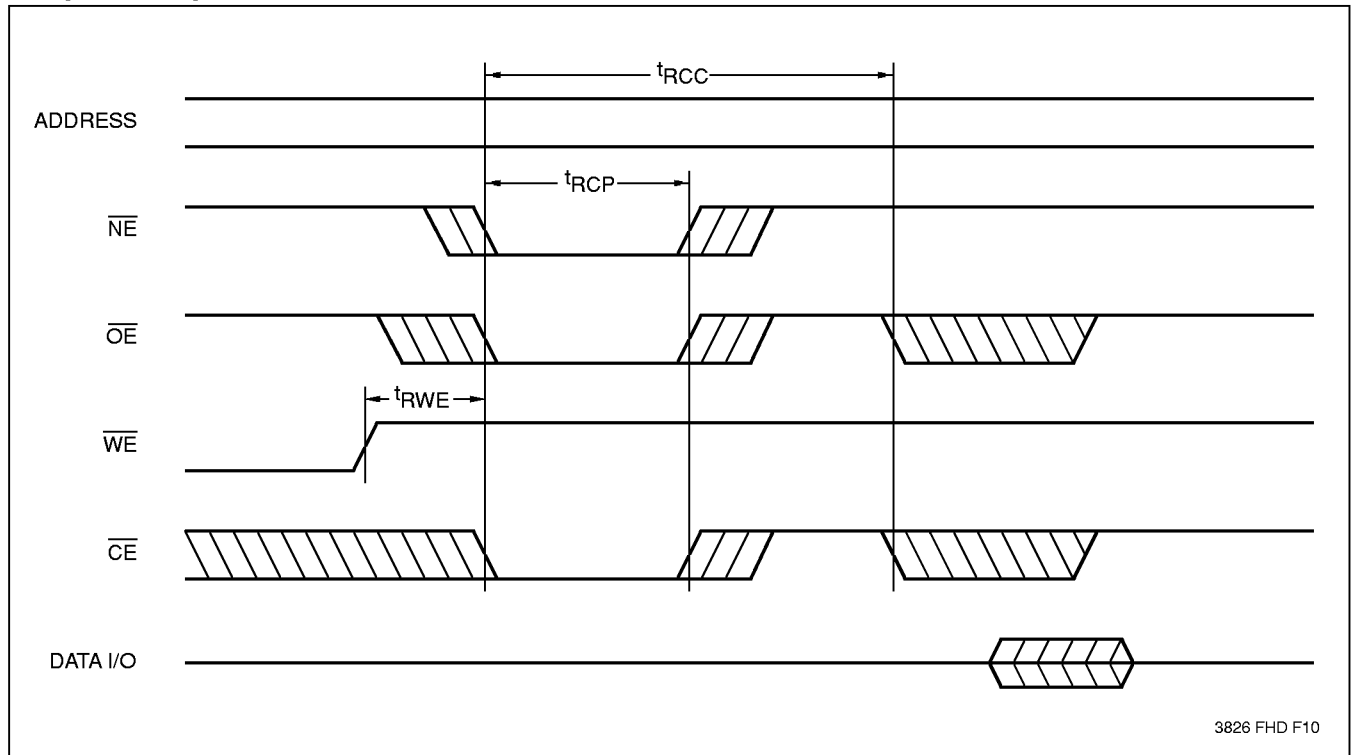

3826 FHD F10

Note: (5) The Recall Pulse Width (t_{RCP}) is a minimum time that \overline{NE} , \overline{OE} and \overline{CE} must be LOW simultaneously to insure data integrity, \overline{NE} and \overline{CE} .

X20C16

Software Command Timing Limits

Symbol	Parameter	X20C16-35		X20C16-45		X20C16-55		Units
		Min.	Max.	Min.	Max.	Min.	Max.	
t_{STO}	Store Cycle Time		5		5		5	ms
$t_{SP}^{(6)}$	Store Pulse Width	30		40		50		ns
t_{SPH}	Store Pulse Hold Time	35		45		55		ns
t_{WC}	Write Cycle Time	35		45		55		ns
t_{AS}	Address Setup Time	0		0		0		ns
t_{AH}	Address Hold time	0		0		0		ns
t_{DS}	Data Setup Time	15		20		25		ns
t_{DH}	Data Hold Time	3		3		3		ns
$t_{SOE}^{(7)}$	\overline{OE} Disable to Store Function	20		20		20		ns
$t_{OEST}^{(7)}$	Output Enable from End of Store	10		10		10		ns
$t_{NHZ}^{(7)}$	Nonvolatile Enable to Output in High Z		15		20		25	ns
t_{NES}	\overline{NE} Setup Time	5		5		5		ns
t_{NEH}	\overline{NE} Hold Time	5		5		5		ns

3826 PGM T12.2

\overline{CE} Controlled Software Command Sequence

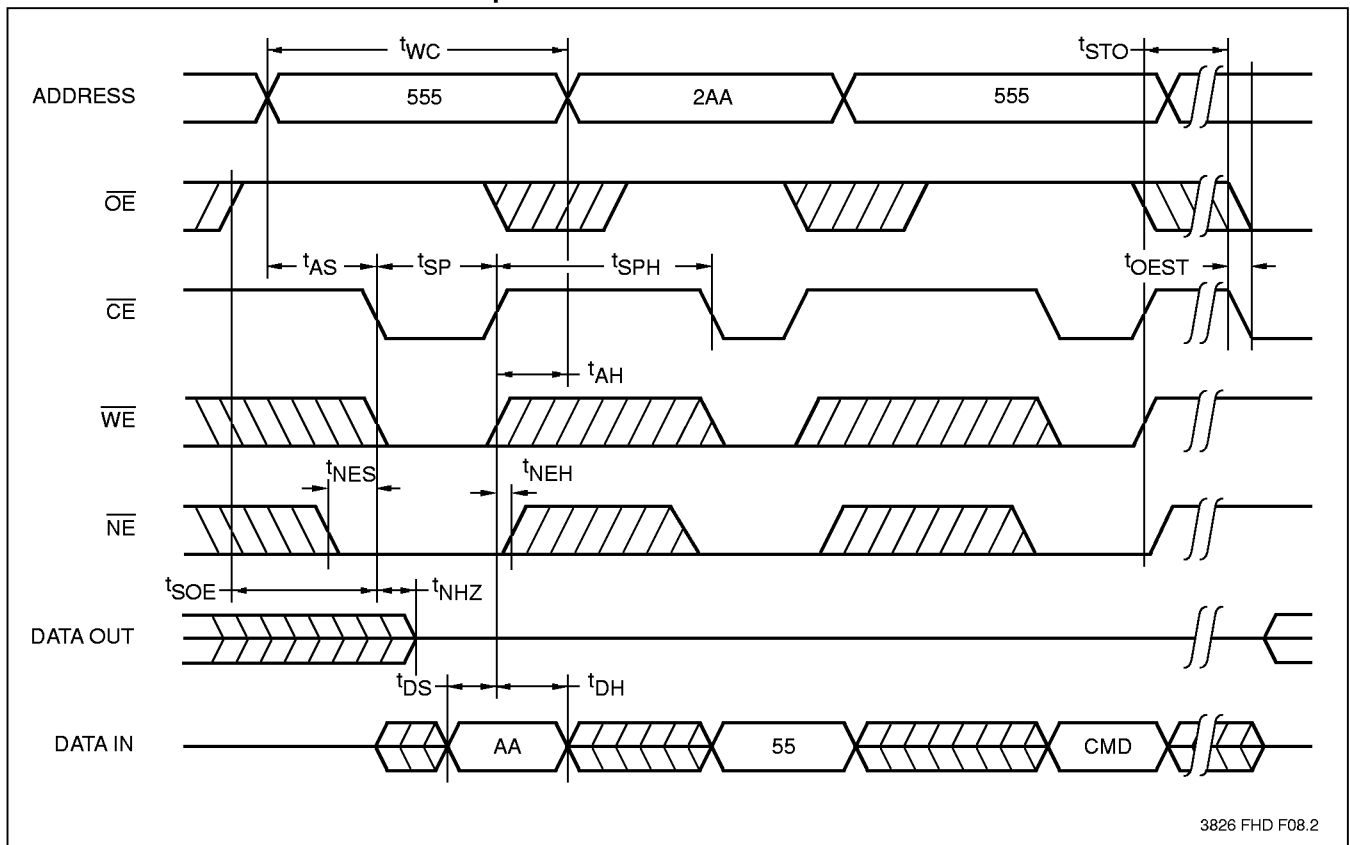

3826 FHD F08.2

Note: (6) The Store Pulse Width (t_{SP}) is a minimum time that \overline{NE} , \overline{WE} and \overline{CE} must be LOW simultaneously.
 (7) t_{SOE} , t_{OEST} and t_{NHZ} are periodically sampled and not 100% tested.

X20C16

\overline{WE} Controlled Software Command Sequence

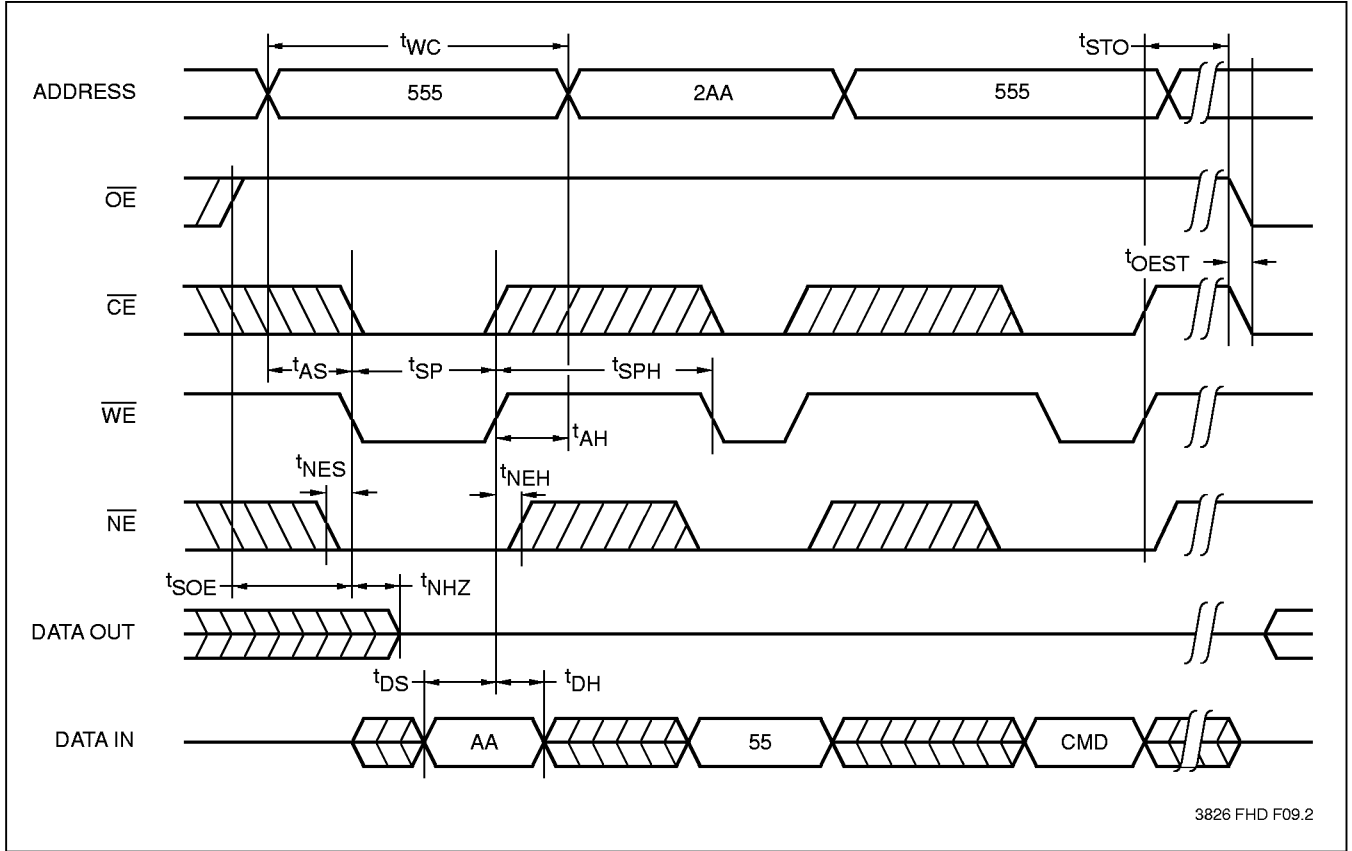

X20C16

AUTOSTORE Feature

The AUTOSTORE feature automatically saves the contents of the X20C16's static RAM to the on-board bit-for-bit shadow E²PROM at power-down. This circuitry insures that no data is lost during accidental power-downs or general system crashes, and is ideal for microprocessor caching systems, embedded software systems, and general system back-up memory.

The AUTOSTORE instruction (EAS) to the SDP register sets the AUTOSTORE enable latch, allowing the X20C16 to automatically perform a store operation whenever V_{CC} falls below the AUTOSTORE threshold (V_{ASTH}). V_{CC} must remain above the AUTOSTORE Cycle End Voltage (V_{ASEND}) for the duration of the store cycle (t_{ASTO}). The detailed timing for this feature is illustrated in the AUTOSTORE timing diagram, below. Once the AUTOSTORE cycle is initiated, all other device functions are inhibited.

AUTOSTORE CYCLE Timing Diagrams

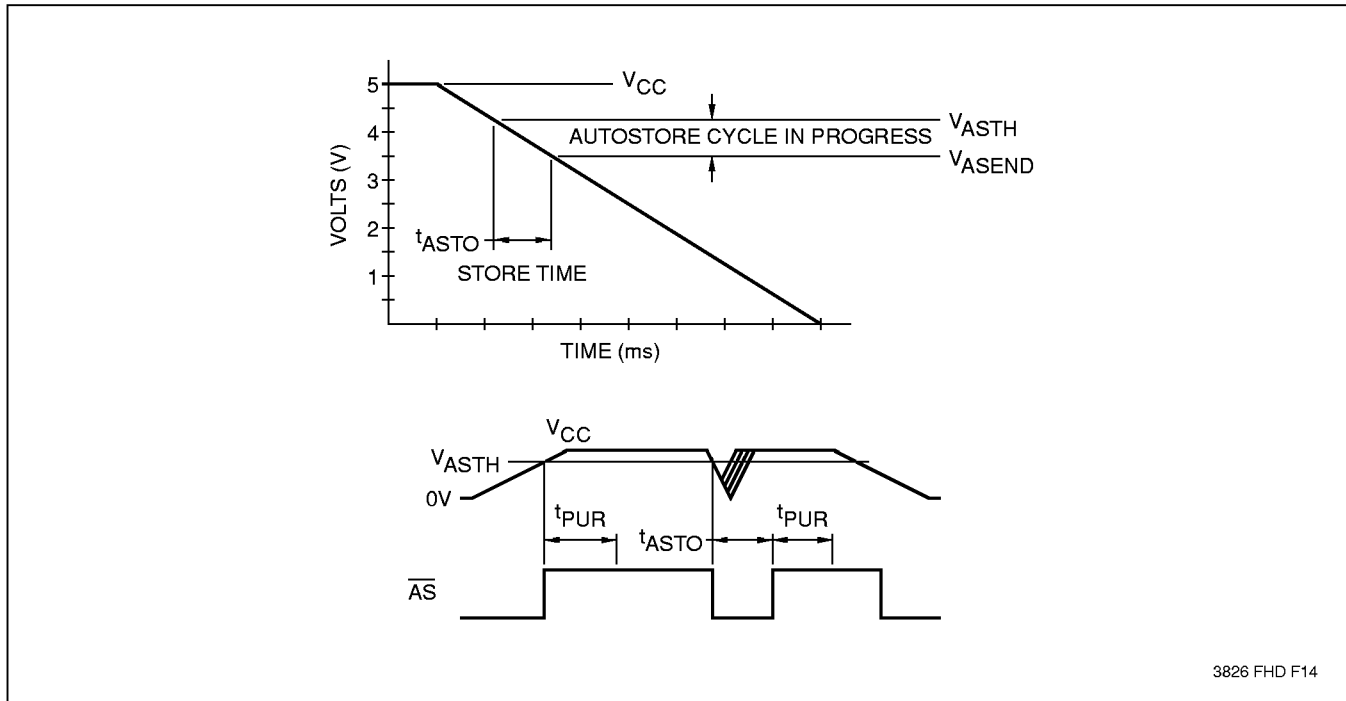

3826 FHD F14

AUTOSTORE CYCLE LIMITS

Symbol	Parameter	X20C16		Units
		Min.	Max.	
t_{ASTO}	AUTOSTORE Cycle Time		2.5	ms
V_{ASTH}	AUTOSTORE Threshold Voltage	4.0	4.3	V
V_{ASEND}	AUTOSTORE Cycle End Voltage	3.5		V

3826 PGM T15

X20C16

SDP (Software Data Protection)

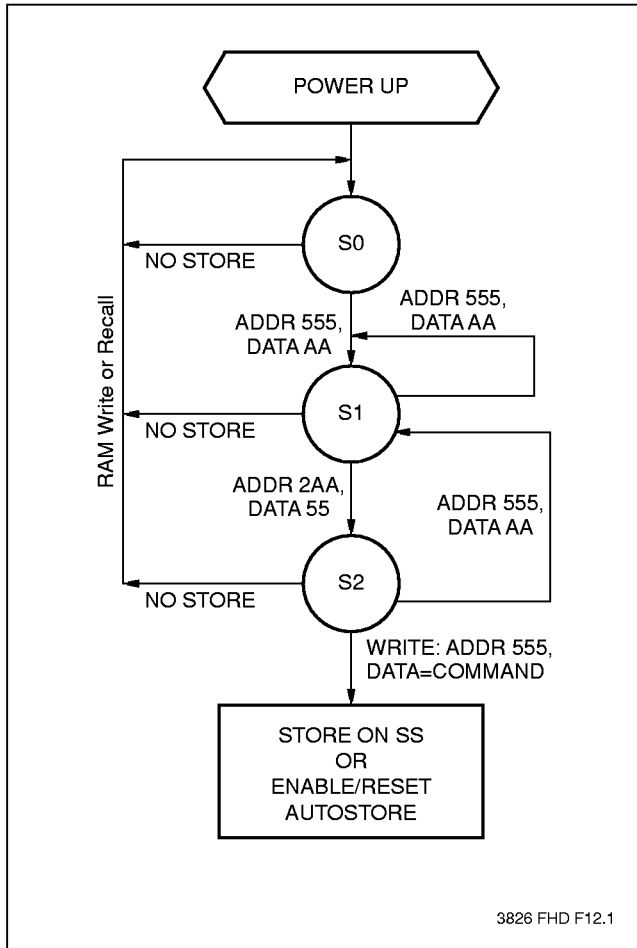

Store State Diagram

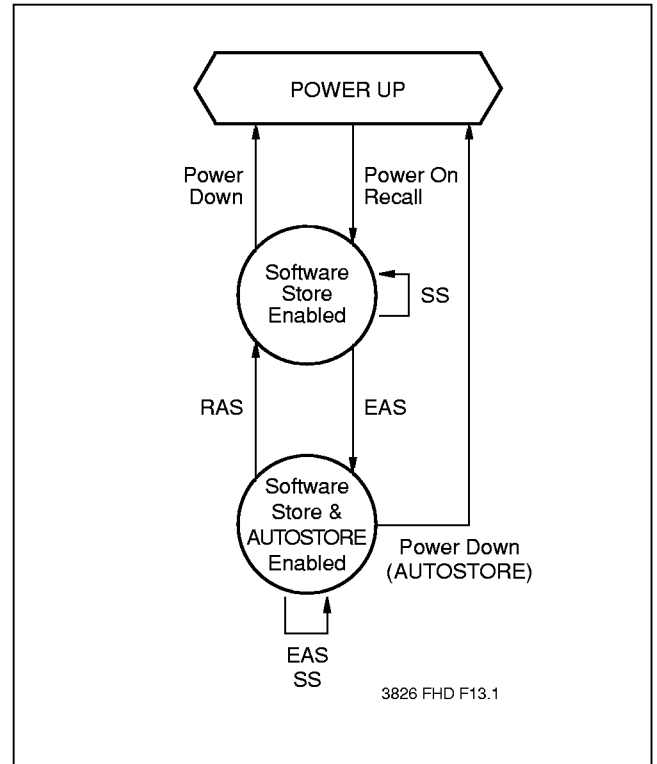

SOFTWARE DATA PROTECTION COMMANDS

Command		Data
EAS	Enable AUTOSTORE	CC[H]
RAS	Reset AUTOSTORE	CD[H]
SS	Software Store	33[H]

3826 PGM T14.1

NOTES

X20C16

PACKAGING INFORMATION

28-LEAD PLASTIC DUAL IN-LINE PACKAGE TYPE P

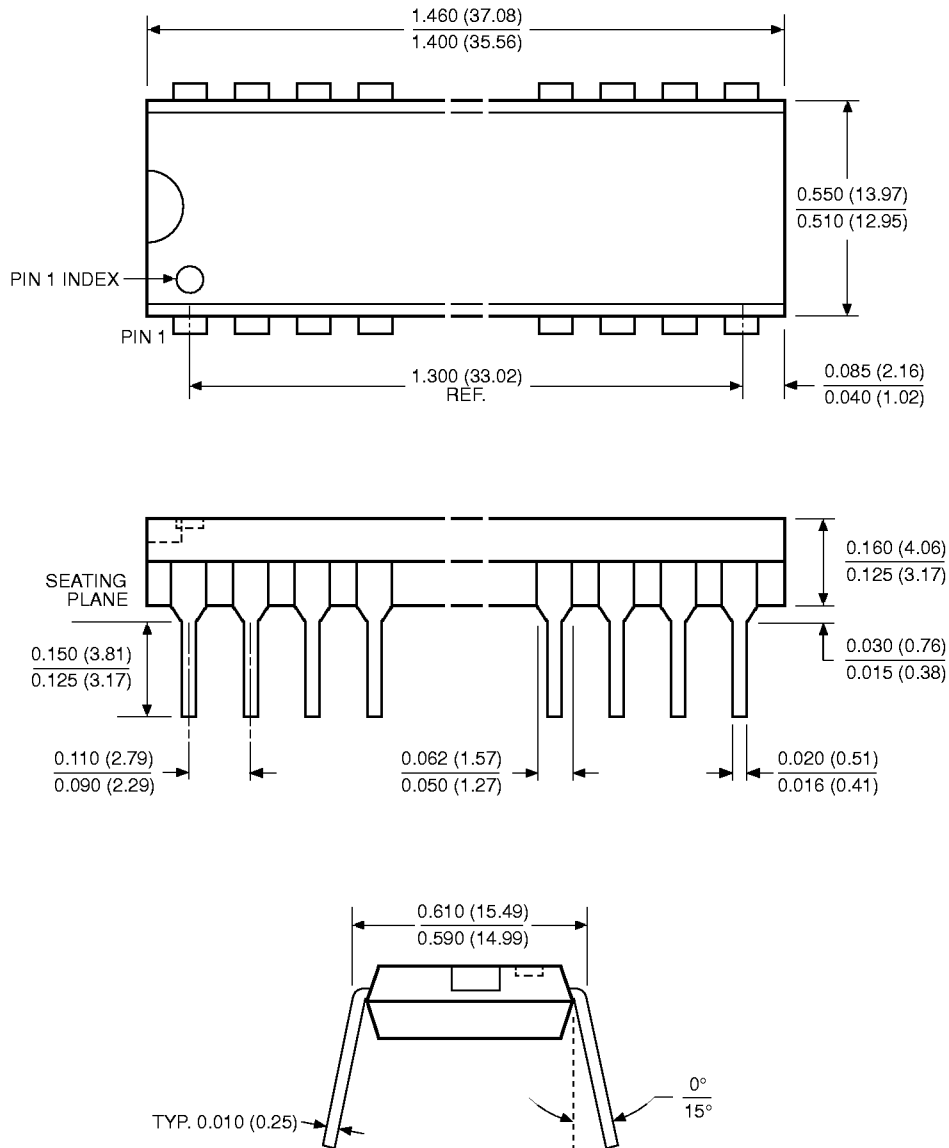

NOTE: ALL DIMENSIONS IN INCHES (IN PARENTHESES IN MILLIMETERS)

3926 FHD F04

X20C16

PACKAGING INFORMATION

32-PAD CERAMIC LEADLESS CHIP CARRIER PACKAGE TYPE E

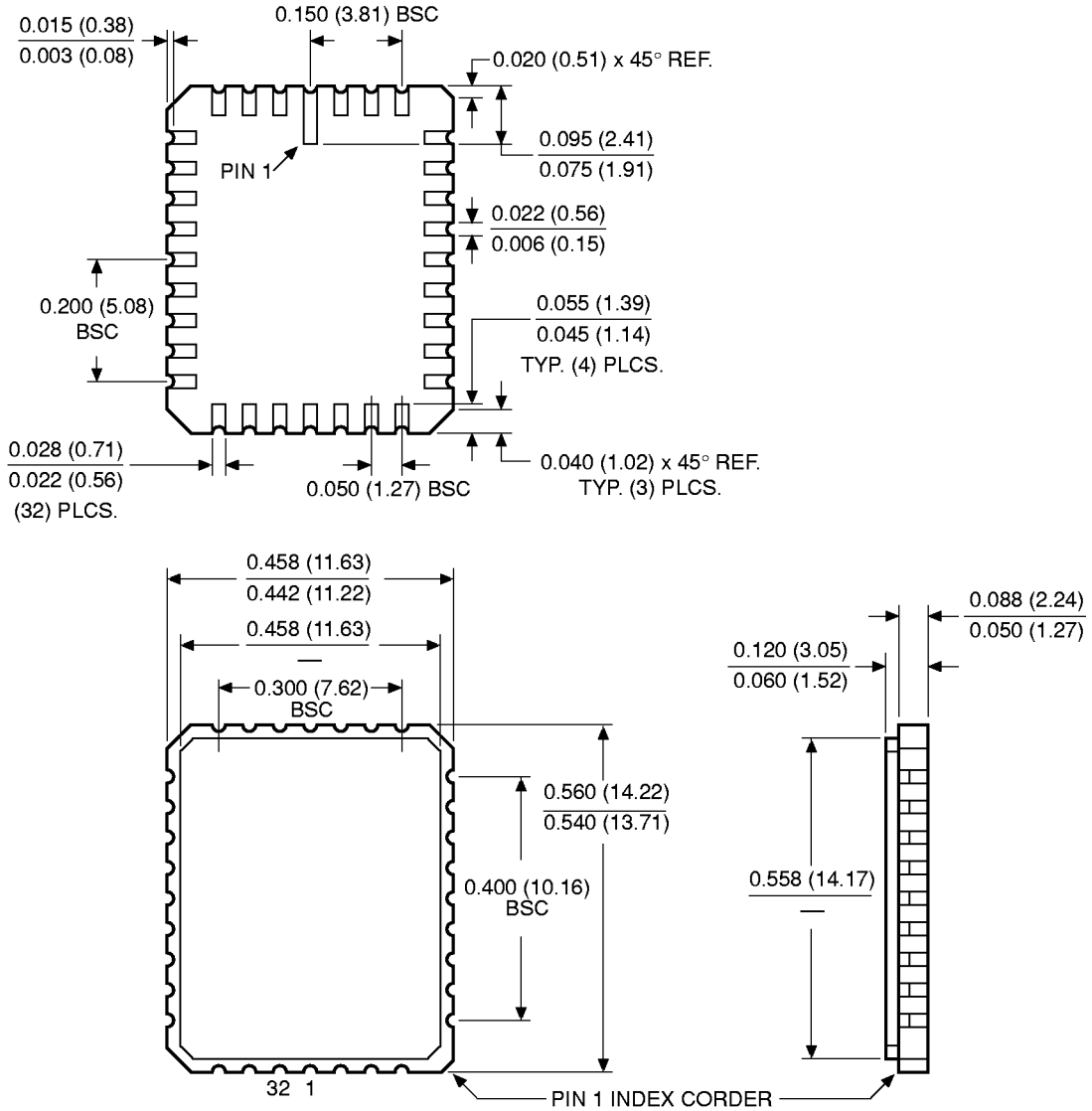

- NOTE:**
1. ALL DIMENSIONS IN INCHES (IN PARENTHESES IN MILLIMETERS)
 2. TOLERANCE: $\pm 1\%$ NTL ± 0.005 (0.127)

X20C16

PACKAGING INFORMATION

32-LEAD PLASTIC LEADED CHIP CARRIER PACKAGE TYPE J

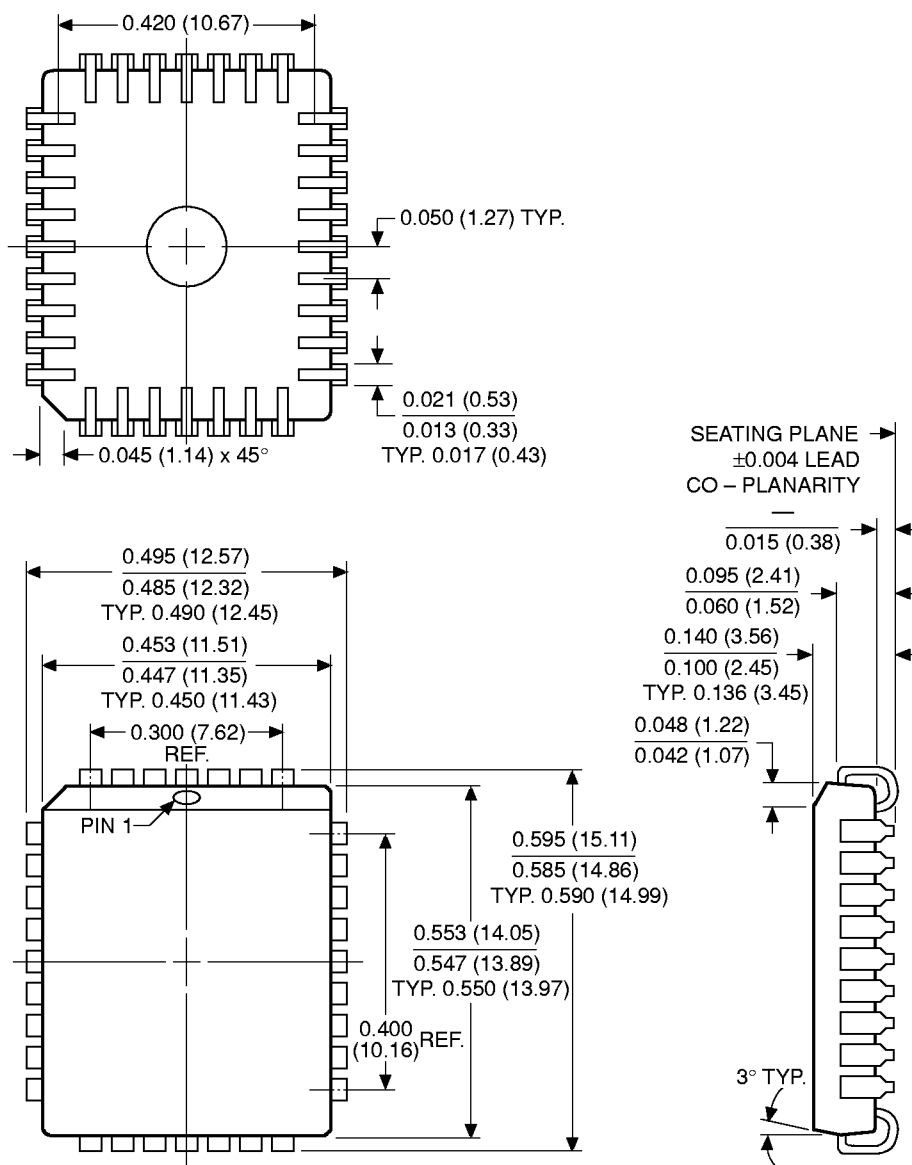

NOTES:

1. ALL DIMENSIONS IN INCHES (IN PARENTHESES IN MILLIMETERS)
2. DIMENSIONS WITH NO TOLERANCE FOR REFERENCE ONLY

3926 FHD F13

X20C16

PACKAGING INFORMATION

28-LEAD PLASTIC SMALL OUTLINE GULL WING PACKAGE TYPE S

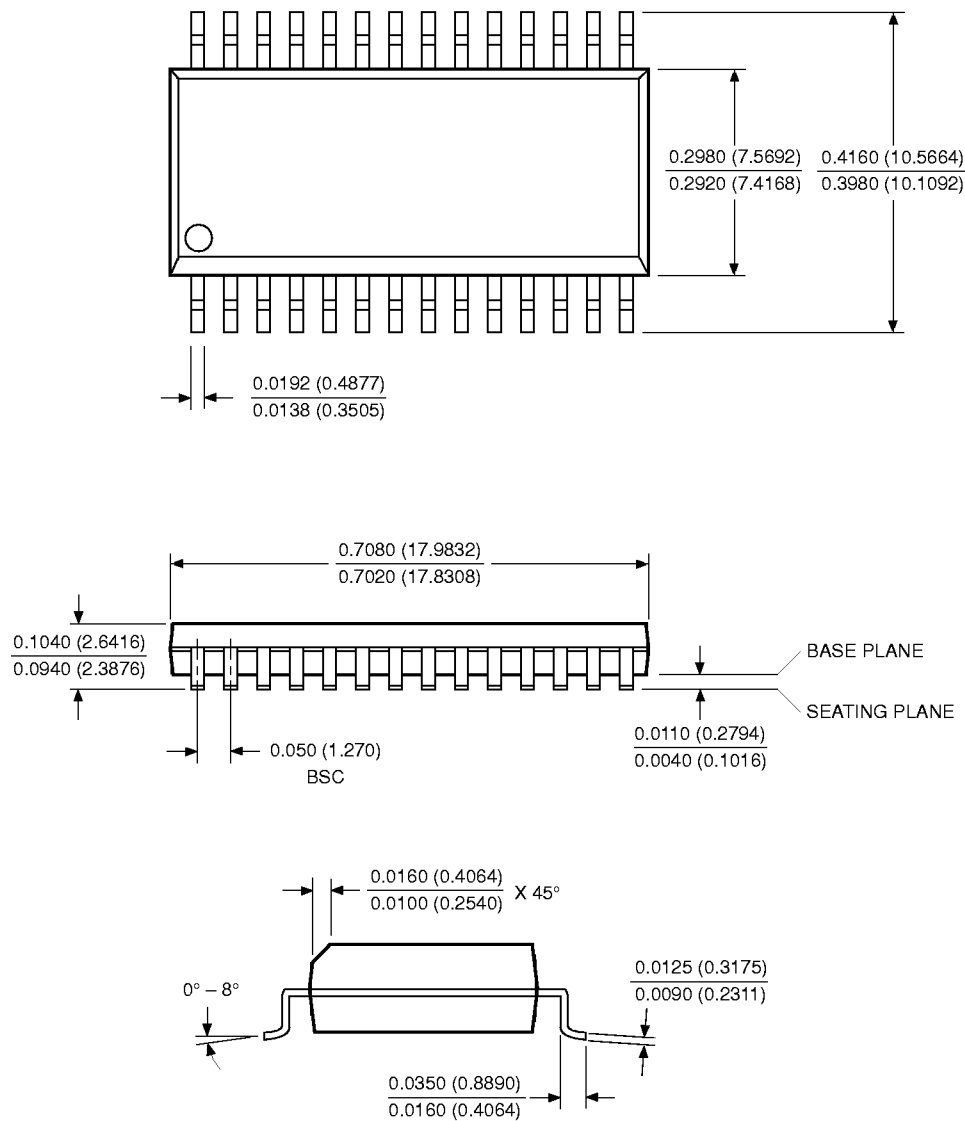

NOTES:

1. ALL DIMENSIONS IN INCHES (IN PARENTHESES IN MILLIMETERS)
2. FORMED LEAD SHALL BE PLANAR WITH RESPECT TO ONE ANOTHER WITHIN 0.004 INCHES
3. BACK EJECTOR PIN MARKED "KOREA"
4. CONTROLLING DIMENSION: INCHES (MM)

3926 FHD F17

X20C16

PACKAGING INFORMATION

32-LEAD THIN SMALL OUTLINE PACKAGE (TSOP) TYPE T

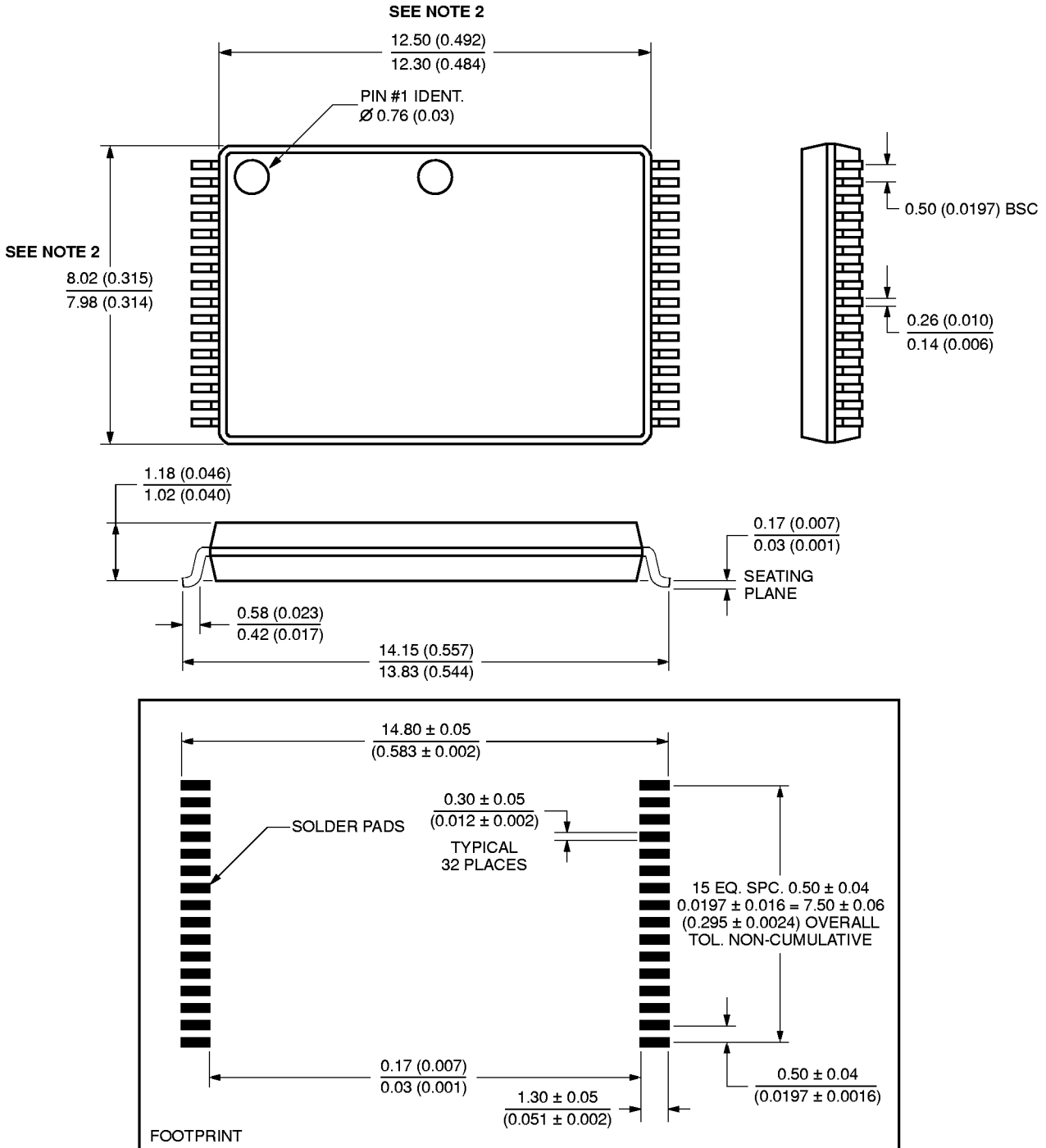

NOTE:
1. ALL DIMENSIONS ARE SHOWN IN MILLIMETERS (INCHES IN PARENTHESES).

3926 ILL F38.1

X20C16

ORDERING INFORMATION

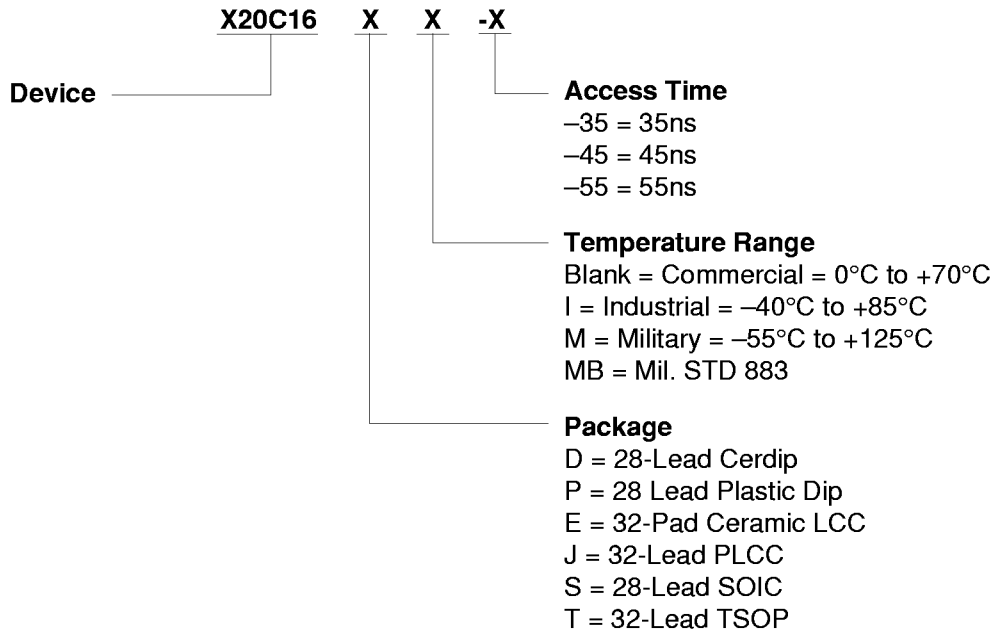

LIMITED WARRANTY

Devices sold by Xicor, Inc. are covered by the warranty and patent indemnification provisions appearing in its Terms of Sale only. Xicor, Inc. makes no warranty, express, statutory, implied, or by description regarding the information set forth herein or regarding the freedom of the described devices from patent infringement. Xicor, Inc. makes no warranty of merchantability or fitness for any purpose. Xicor, Inc. reserves the right to discontinue production and change specifications and prices at any time and without notice.

Xicor, Inc. assumes no responsibility for the use of any circuitry other than circuitry embodied in a Xicor, Inc. product. No other circuits, patents, licenses are implied.

US. PATENTS

Xicor products are covered by one or more of the following U.S. Patents: 4,263,664; 4,274,012; 4,300,212; 4,314,265; 4,326,134; 4,393,481; 4,404,475; 4,450,402; 4,486,769; 4,488,060; 4,520,461; 4,533,846; 4,599,706; 4,617,652; 4,668,932; 4,752,912; 4,829,482; 4,874,967; 4,883,976. Foreign patents and additional patents pending.

LIFE RELATED POLICY

In situations where semiconductor component failure may endanger life, system designers using this product should design the system with appropriate error detection and correction, redundancy and back-up features to prevent such an occurrence.

Xicor's products are not authorized for use as critical components in life support devices or systems.

1. Life support devices or systems are devices or systems which, (a) are intended for surgical implant into the body, or (b) support or sustain life, and whose failure to perform, when properly used in accordance with instructions for use provided in the labeling, can be reasonably expected to result in a significant injury to the user.
2. A critical component is any component of a life support device or system whose failure to perform can be reasonably expected to cause the failure of the life support device or system, or to affect its safety or effectiveness.