

UTC 2SD669/A

NPN EPITAXIAL SILICON TRANSISTOR

BIPOLAR POWER GENERAL PURPOSE TRANSISTOR

APPLICATIONS

* Low frequency power amplifier complementary pair with UTC 2SB649/A

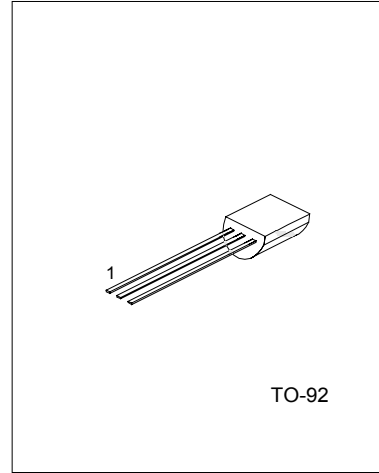

1:EMITTER 2:COLLECTOR 3:BASE

ABSOLUTE MAXIMUM RATINGS (Ta=25°C, unless otherwise specified)

PARAMETER	SYMBOL	RATING	UNIT
Collector-base voltage	V _{CB0}	180	V
Collector-emitter voltage	V _{CEO}	120	V
2SD669		160	
2SD669A			
Emitter-base voltage	V _{EB0}	5	V
Collector current	I _c	1.5	A
Collector peak current	I _{c(peak)}	3	A
Collector power dissipation	P _c	1	W
Collector power dissipation (T _c =25°C)	P _c	20	W
Junction Temperature	T _j	150	°C
Storage Temperature	T _{STG}	-55 ~ +150	°C

ELECTRICAL CHARACTERISTICS (Ta=25°C, unless otherwise specified)

PARAMETER	SYMBOL	TEST CONDITIONS	MIN	TYP	MAX	UNIT
Collector to bse breakdown voltage	V _{(BR)CBO}	I _c =1mA, I _E =0	180			V
Collector to emitter breakdown voltage	V _{(BR)CEO}	I _c =10mA, R _{BE} =∞	120			V
2SD669			160			
2SD669A						
Emitter to base breakdown voltage	V _{(BR)EBO}	I _E =1mA, I _c =0	5			V
Collector cut-off current	I _{CBO}	V _{CB} =160V, I _E =0			10	μA
DC current gain	2SD669	h _{FE1}	V _{CE} =5V, I _c =150mA (note)	60		320
		h _{FE2}	V _{CE} =5V, I _c =500mA (note)	30		
	2SD669A	h _{FE1}	V _{CE} =5V, I _c =150mA (note)	60		200
		h _{FE2}	V _{CE} =5V, I _c =500mA (note)	30		
Collector-emitter saturation voltage	V _{CE(sat)}	I _c =600mA, I _B =50mA (note)			1	V
Base-emitter voltage	V _{BE}	V _{CE} =5V, I _c =150mA (note)			1.5	V

UTC UNISONIC TECHNOLOGIES CO. LTD

UTC 2SD669/A

NPN EPITAXIAL SILICON TRANSISTOR

PARAMETER	SYMBOL	TEST CONDITIONS	MIN	TYP	MAX	UNIT
Current gain bandwidth product	f_T	$V_{CE}=5V, I_C=150mA$ (note)		140		MHz
Output capacitance	C_{ob}	$V_{CB}=10V, I_E=0, f=1MHz$		14		pF

Note: Pulse test.

CLASSIFICATION OF h_{FE1}

RANK	B	C	D
RANGE (2SD669)	60-120	100-200	160-320
RANGE (2SD669A)	60-120	100-200	160-320

TYPICAL PARAMETERS PERFORMANCE

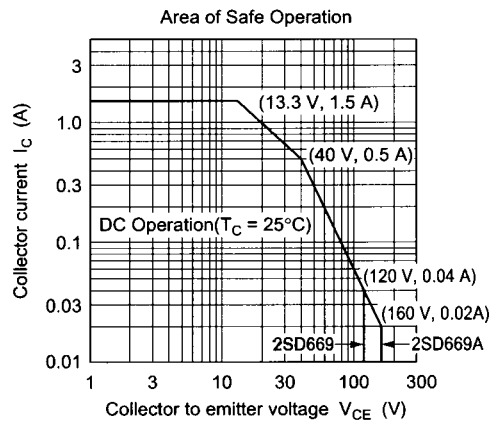
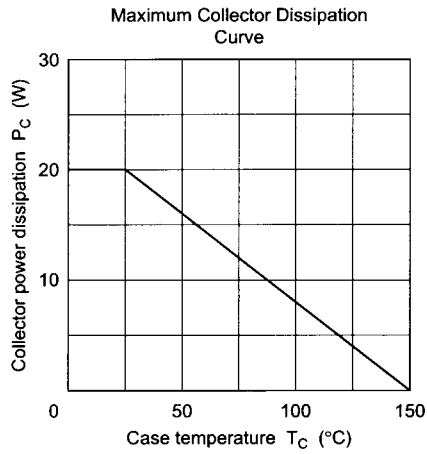

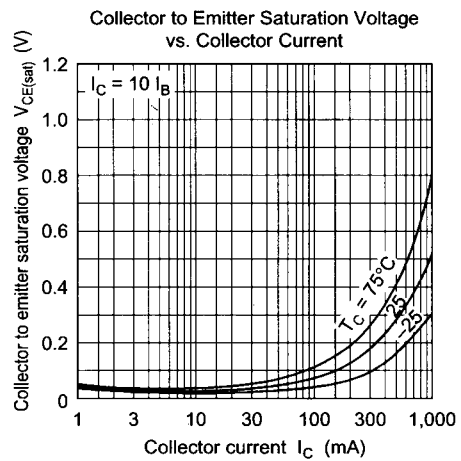
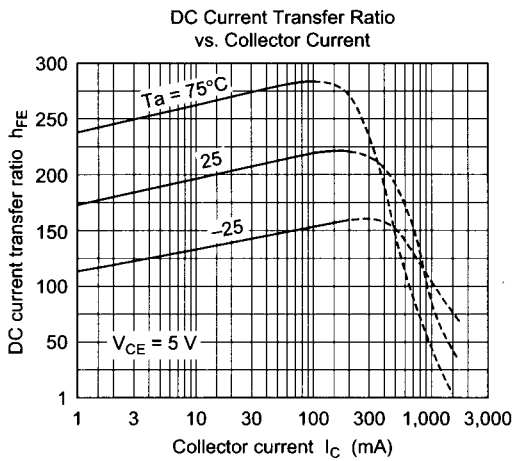
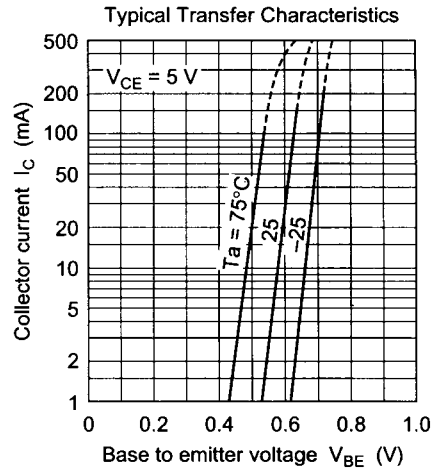
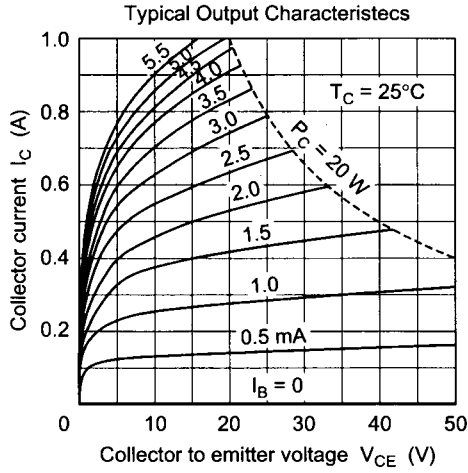

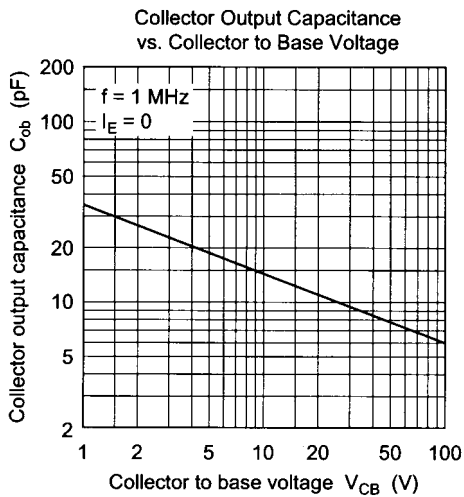
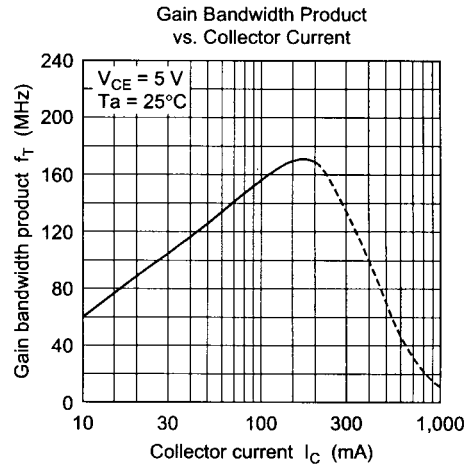
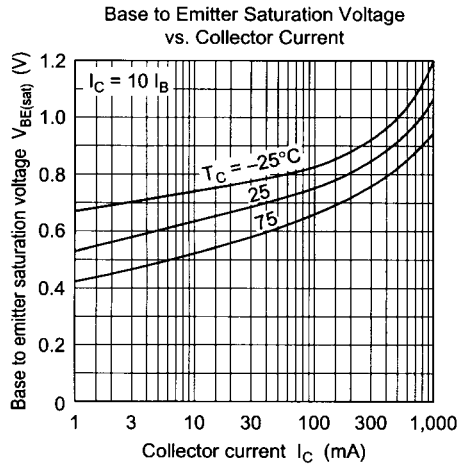

UTC assumes no responsibility for equipment failures that result from using products at values that exceed, even momentarily, rated values (such as maximum ratings, operating condition ranges, or other parameters) listed in products specifications of any and all UTC products described or contained herein. UTC products are not designed for use in life support appliances, devices or systems where malfunction of these products can be reasonably expected to result in personal injury. Reproduction in whole or in part is prohibited without the prior written consent of the copyright owner. The information presented in this document does not form part of any quotation or contract, is believed to be accurate and reliable and may be changed without notice.