

Dual output voltage regulator with power saving

BA44W12SAT

The BA44W12SAT is a general-purpose power supply with outputs : 8V, 1A and 8V, 500mA. The IC is available in a compact TO220FP-5 package. The outputs can be turned off during the power saving state with a built-in switch. Also built in the IC are an overcurrent protection circuit, an overvoltage protection circuit, and a thermal shutdown circuit.

●Applications

Car audio systems, VCRs, facsimiles, air conditions, and other household and industrial equipment

●Features

- 1) Minimum I / O voltage differential is 0.5V or less.
- 2) Built-in protection circuits against overcurrent, over voltage, and overheat.
- 3) Available in a compact TO220FP-5 package (pins are bendable)
- 4) Zero power saving current. (Typ.)

●Absolute maximum ratings (Ta=25°C)

Parameter	Symbol	Limits	Unit
Power supply voltage	V _{CC}	35	V
Power dissipation	P _d	2000*1	mW
Operating temperature	T _{opr}	-40~+85	°C
Storage temperature	T _{stg}	-55~+150	°C
Peak applied voltage	V _{CCPeak}	50*2	V

*1 Reduced by 16mW for each increase in Ta of 1°C over 25°C.

*2 Applied time is less than 200ms (tr≥1ms).

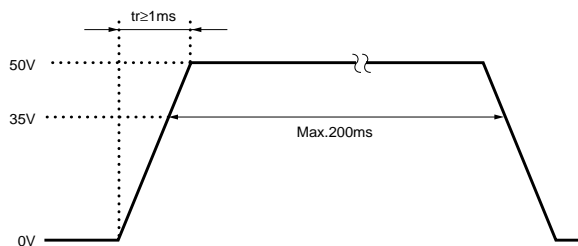

●Recommended operating conditions (Ta=25°C)

Parameter	Symbol	Min.	Typ.	Max.	Unit
Power supply voltage	V _{CC}	9.0	13	25	V

Regulator ICs

●Block diagram

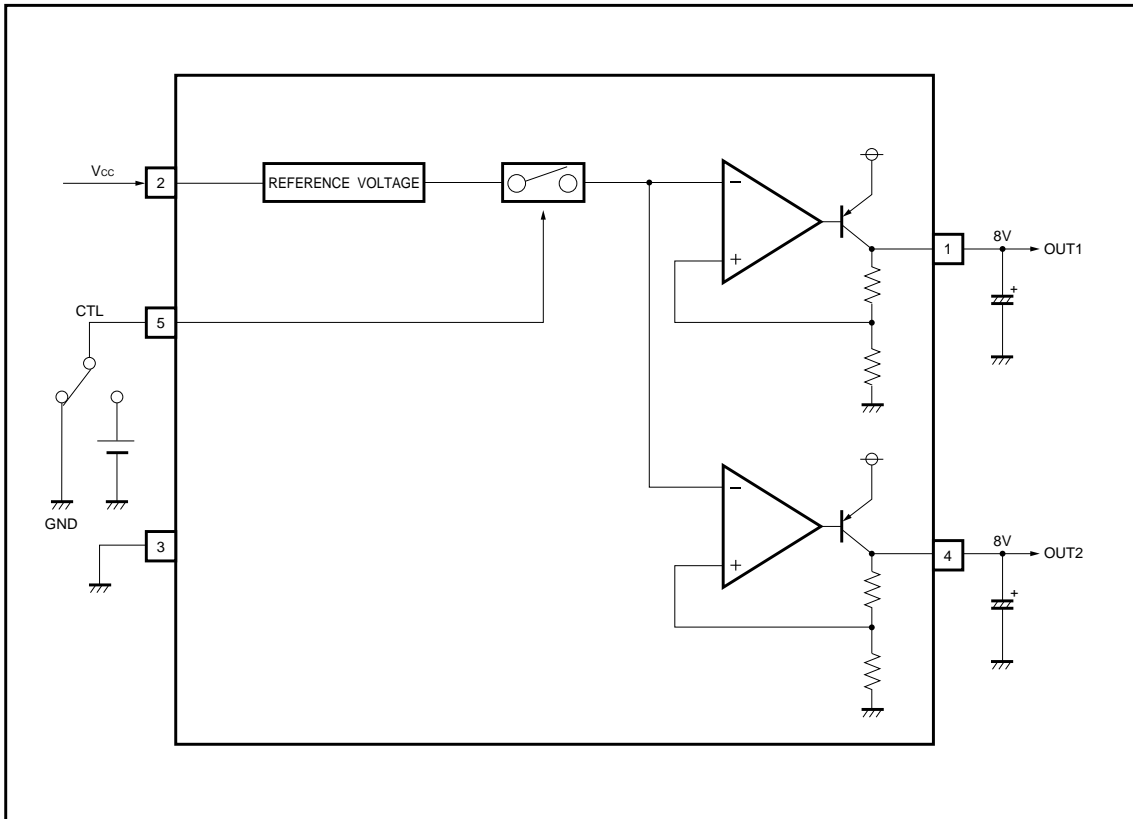

●Pin descriptions

Pin No.	Pin name	Function
1	OUT1	Output 1 (8V, 1A)
2	Vcc	Power supply
3	GND	Ground
4	OUT2	Output 2 (8V, 500mA)
5	CTL	ON / OFF switch

Regulator ICs

●Input / output circuits

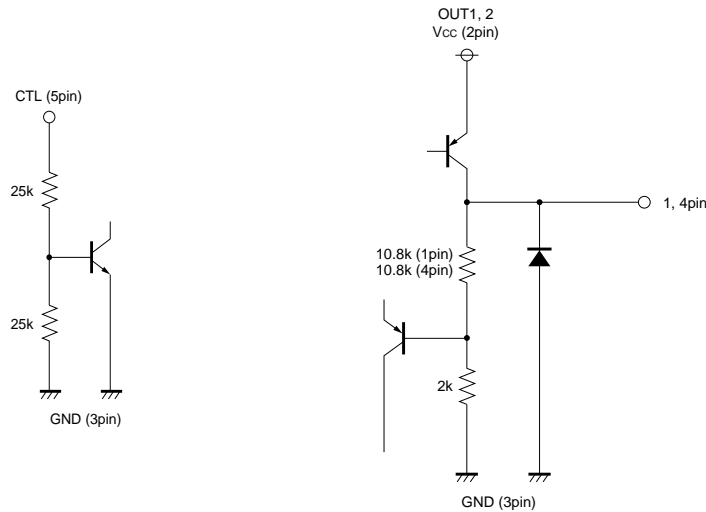

●Electrical characteristics (unless otherwise noted, Ta=25°C, Vcc=13.0V)

Parameter	Symbol	Min.	Typ.	Max.	Unit	Conditions	Test circuit
Power save supply current	I _{ST}	-	0	10	μA	OFF mode	Fig.4
Bias current	I _b	-	3.0	5.0	mA	ON mode	Fig.4
<8V output section> (Output 1)							
Output voltage 1	V _{O1}	7.6	8.0	8.4	V	I _{O1} =500mA	Fig.1
Minimum I / O voltage differential 1	ΔV _{O1}	-	0.3	0.5	V	I _{O1} =500mA V _{CC} =7.6V	Fig.3
Output current capacity 1	I _{O1}	1.0	-	-	A		Fig.1
Ripple rejection ratio 1	R.R1	-	55	-	dB	I _{O1} =500mA, f=120Hz e _{IN} =1Vrms	Fig.2
Input stability 1	Reg.I1	-	50	100	mV	V _{CC} =9→25V, I _O =500mA	Fig.1
Load regulation 1	Reg.L1	-	100	150	mV	I _O =5mA→1A	Fig.1
Output short-circuit current 1	I _{OS1}	-	150	-	mA	V _{CC} =25V	Fig.5
<8V output section> (Output 2)							
Output voltage 2	V _{O2}	7.6	8.0	8.4	V	I _{O2} =350mA	Fig.1
Minimum I / O voltage differential 2	ΔV _{O2}	-	0.3	0.5	V	I _{O2} =350mA V _{CC} =7.6V	Fig.3
Output current capacity 2	I _{O2}	500	-	-	mA		Fig.1
Ripple rejection ratio 2	R.R2	-	60	-	dB	I _{O2} =350mA, f=120Hz e _{IN} =1Vrms	Fig.2
Input stability 2	Reg.I2	-	50	100	mV	V _{CC} =9→25V, I _O =350mA	Fig.1
Load regulation 2	Reg.L2	-	50	100	mV	I _O =5mA→500mA	Fig.1
Output short-circuit current 2	I _{OS2}	-	100	-	mA	V _{CC} =25V	Fig.5
<CTL section>							
ON mode voltage	V _{th1}	2.0	-	-	V	Output ACTIVE MODE	Fig.6
OFF mode voltage	V _{th2}	-	-	0.8	V	Output OFF MODE	Fig.6
Input high level current	I _{IN}	-	150	-	μA	V _{th} =5V	Fig.7

Note) All the characteristic values are measured with a 0.33μF-capacitor connected the input pin and 22μF-capacitor connected to the output pin. Measurements are made by using a plus (tw≤10ms, duty cycle≤5%) in all cases but noise voltage and the ripple rejection ratio.

Regulator ICs

● Measurement circuits

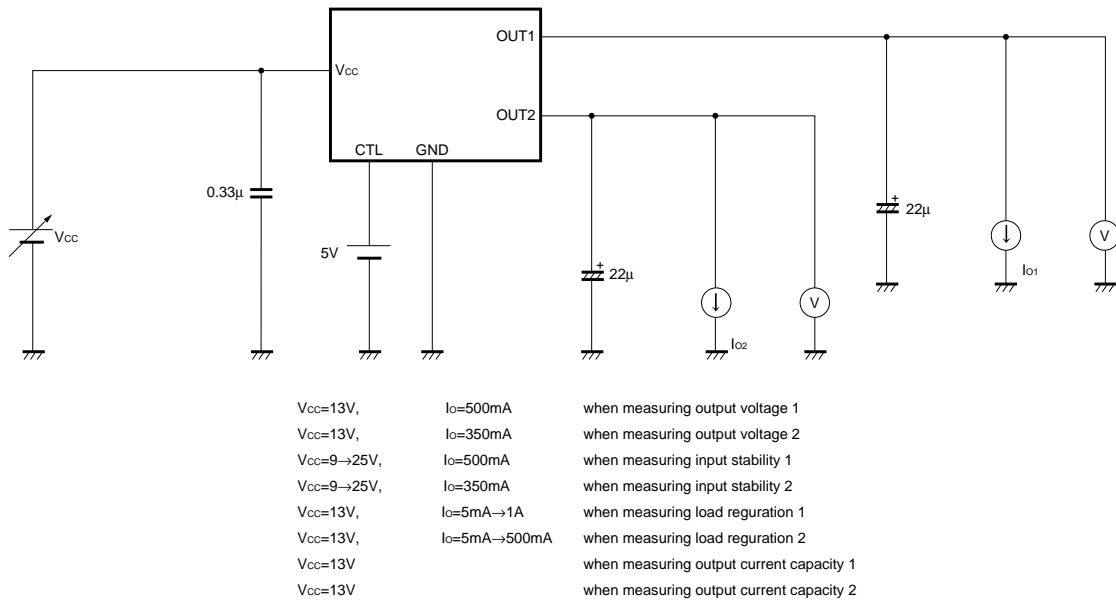

Fig.1 Circuit for measuring output voltage, input stability, load regulation, and output current capacity

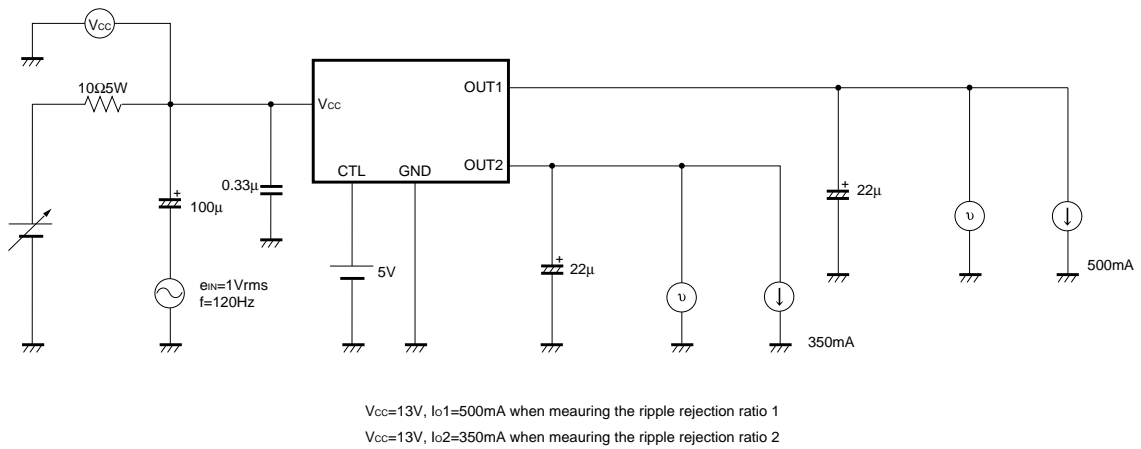

Fig.2 Circuit for measuring ripple rejection ratio

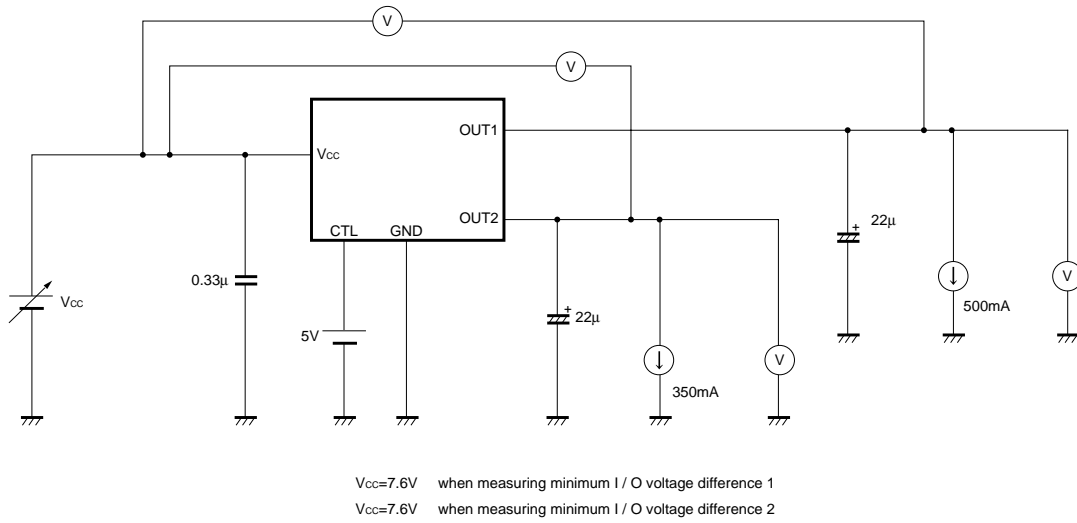

Fig.3 Circuit for measuring minimum I / O voltage difference

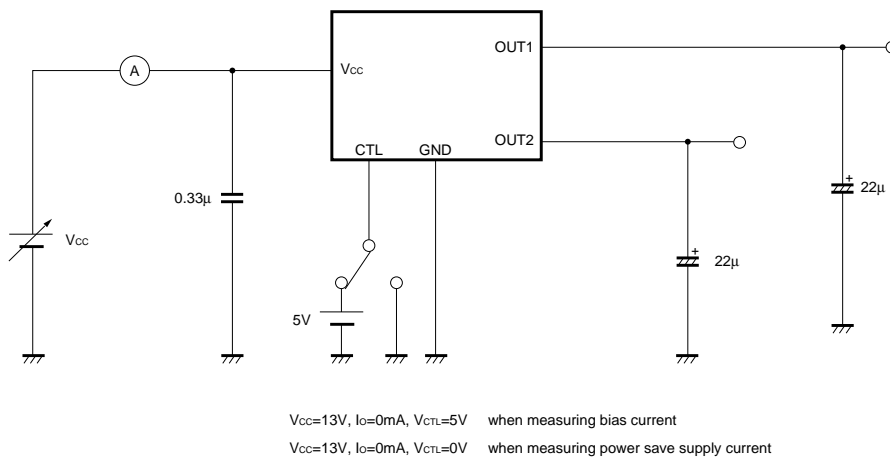

Fig.4 Circuit for measuring bias current and power save supply current

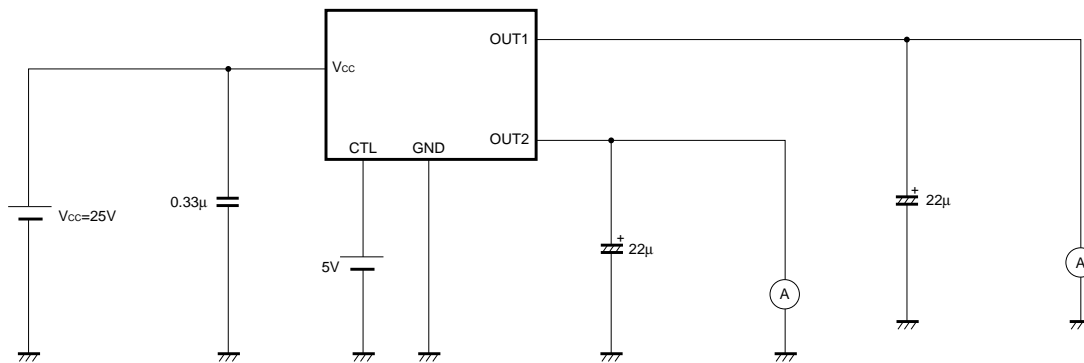

Fig.5 Circuit for measuring output short-circuit current

Regulator ICs

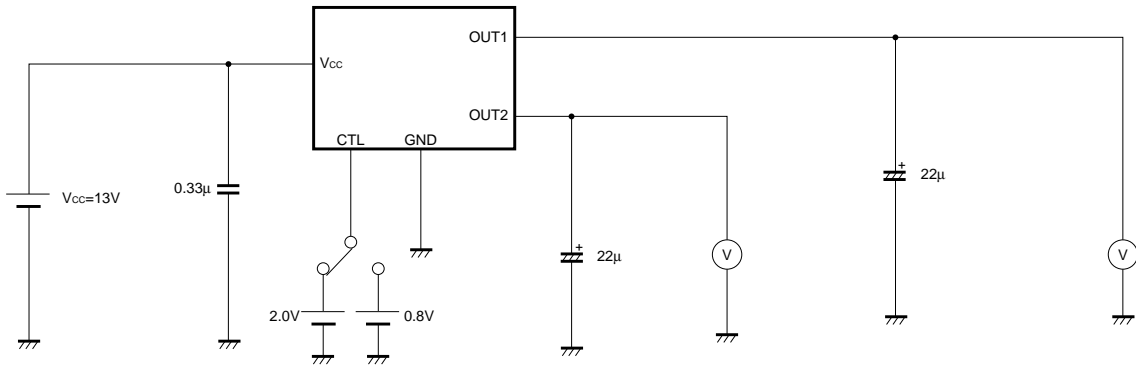

Fig.6 Circuit for measuring mode switching voltage

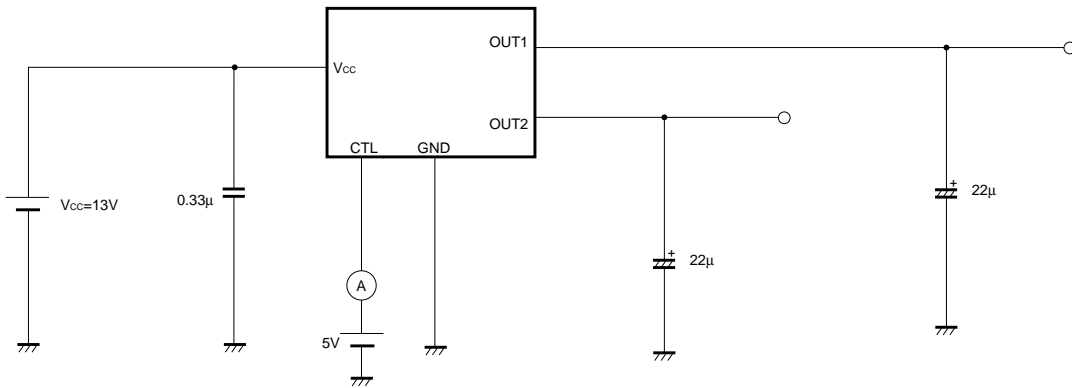

Fig.7 Circuit for measuring input high level current

●Application circuit

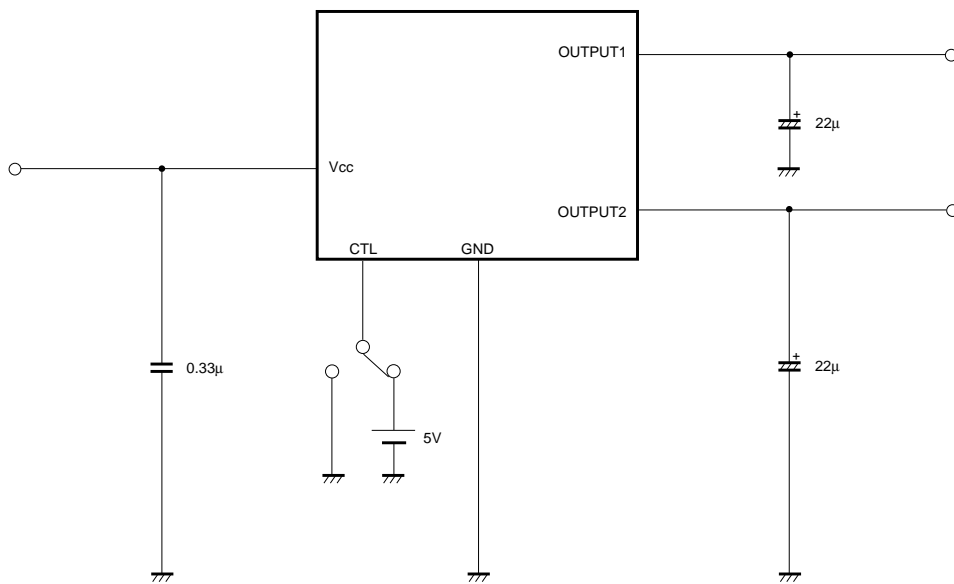

Fig.8

Regulator ICs

●Operation notes

- (1) Although the circuit examples included in this hand-book are highly recommendable for general use, you should be thoroughly familiar with circuit characteristics as they relate to your own use conditions. If you intend to change the number of external circuits, leave an ample margin, taking into account discrepancies in both static and dynamic characteristics of external parts and Rohm ICs. In addition, please be advised that Rohm cannot provide complete assurance regarding patent rights.
- (2) Operating power supply voltage
When operating within the proper ranges of power supply voltage and ambient temperature, most circuit functions are guaranteed. Although the rated values of electrical characteristics cannot be absolutely guaranteed, characteristic values do not change drastically within the proper ranges.
- (3) Power dissipation (Pd)
Refer to the power dissipation characteristics in Fig.12. If power dissipation exceeds the allowable limit, the functionality of the IC will be degraded (such as reduction of current capacity by increased chip temperature). Make sure to use the IC within the allowable range of power dissipation with a sufficient margin.
- (4) Preventing oscillation at each output and bypass capacitor
To stop output oscillation, make sure to connect a capacitor between GND and each output pin (capacitance of at least 10 μ F over the whole operating temperature is recommended). Oscillation can occur if capacitance is susceptible to temperature. We recommended using a tantalum capacitor with minimal changes in capacitance. Also, output can be further stabilized by connecting a bypass capacitor of about 0.33 μ F between V_{CC} and GND.
- (5) Overcurrent protection circuit
An overcurrent protection circuit is installed in each output system, based on the respective output current. This prevents IC destruction due to overcurrent, by limiting the current with a curve shape of "7" in the voltage-current graph. The IC is designed with margins so that current flow will be restricted and latching will be prevented even if a large current suddenly flows through a large capacitor. Note that these protection circuits are only good for preventing damage from sudden accidents. Make sure your design does not case the protection circuit to operate continuously under transitional conditions (for instance, if output is clamped at 1V_F or higher, short mode circuit operates at 1V_F or lower). Note that the capacitance is negatively correlated with temperature.
- (6) Thermal protection circuit
A built-in thermal protection circuit prevents thermal damage to the IC. All outputs are turned off when the circuit operates, and revert to the original state when the temperature drops to a certain level.
- (7) We recommend installing a bypass line in your application if there is a mode where potential difference between each output and input (V_{CC}) or GND is reversed from the normal state. A reversed mode may cause damage to the IC.
- (8) Although the quality of this IC is rigorously controlled, the IC may be destroyed when the applied voltage or the operating temperature exceeds their absolute maximum ratings. Because short mode or open mode cannot be specified when the IC is destroyed, be sure to take physical safety measures, such as fusing, if any of the absolute maximum ratings might be exceeded.

Regulator ICs

(9) Recommended to put diode for protection in case of output pin connected with large load of impedance or reserve current occurred at initial and output off.

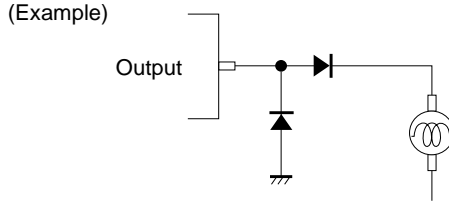

(10) When used within a strong magnetic field, be aware that there is a slight possibility of malfunction.

(11) We are confident in recommending the above application circuit example, but we ask that you carefully check the characteristics of this circuit before using it. If using circuit after modifying other external circuit constants, be careful to ensure adequate margins for variation between external devices and this IC, including not only static characteristics but also transient characteristics.

This IC is a bipolar IC which (as shown in Figure 9) has P+ isolation in the P substrate and between the various pins. A P-N junction is formed from this P layer and the N layer of each pin. For example the relation between each potentials is as follows,

(When $GND > PinB$ and $GND > PinA$, the P-N junction operates as a parasitic diode.)

(When $PinB > GND > PinA$, the P-N junction operates as a parasitic transistor.)

Parasitic diodes can occur inevitably in the structure of the IC. The operation of parasitic diodes can result in mutual interference among circuits as well as operation faults and physical damage. Accordingly, you must not use methods by which parasitic diodes operate, such as applying a voltage that is lower than the GND (P substrate) voltage to an input pin.

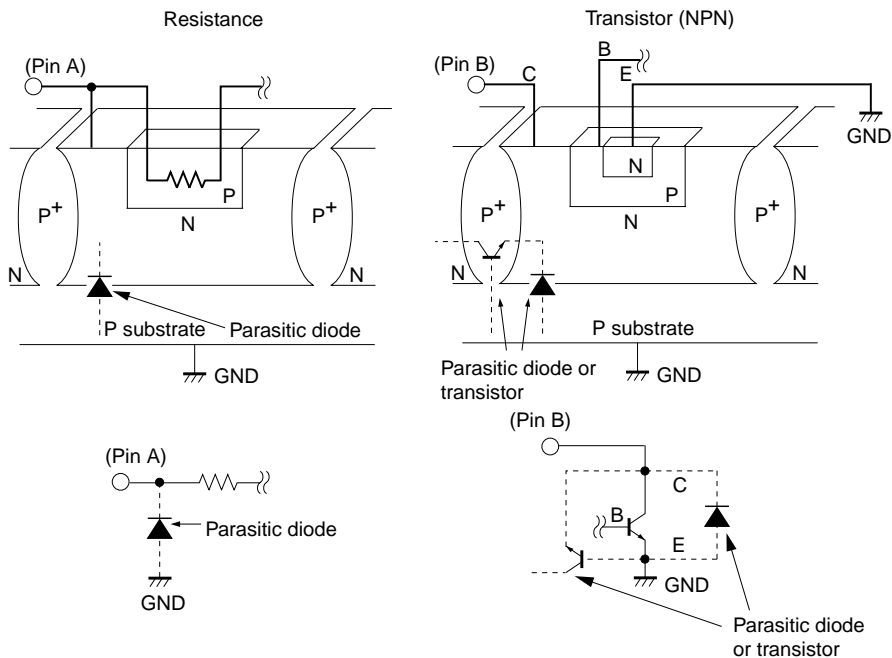

Fig.9 Simplified structure of bipolar IC

Regulator ICs

●Electrical characteristic curves

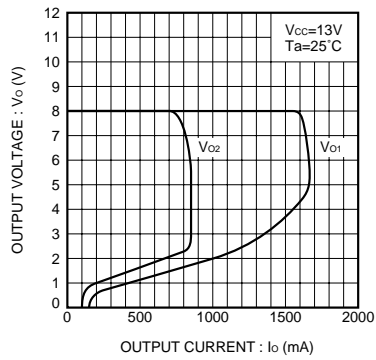

Fig.10 Output current capacity characteristics (Typ.)

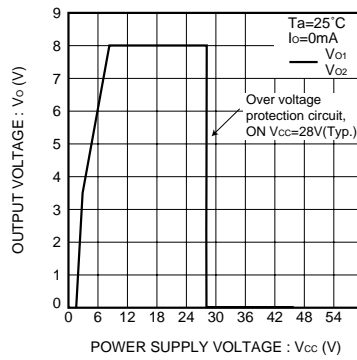

Fig.11 Output voltage characteristics (Typ.)

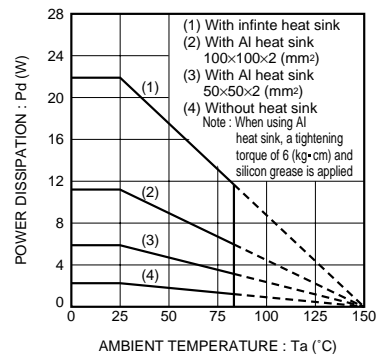

Fig.12 Thermal derating characteristics

●External dimensions (Units : mm)

