

LOW POWER, BANDGAP VOLTAGE REFERENCES

FEATURES

- Output Tolerance 1% or 2%
- Output Voltage Option
 - LM285/385-1.2V 1.235V
 - LM285/385-2.5V 2.5V
- Wide Operating Current Range
 - LM285/385-1.2V 15µA to 20mA
 - LM285/385-2.5V 20µA to 20mA
- Temperature Coefficient 30ppm/°C
- Dynamic Impedance 0.6Ω
- TO-92-3 Plastic Package
- 8-Pin Plastic Narrow Body (SOIC) Package

APPLICATIONS

- ADC and DAC Reference
- Current Source Generation
- Threshold Detectors
- Power Supplies
- Multi-meters

GENERAL DESCRIPTION

The LM285/385-1.2V (1.235V output) and LM285/385-2.5V (2.5V output) are bipolar, two-terminal, bandgap voltage references that offer precision performance without premium price. These devices do not require thin-film resistors, greatly lowering manufacturing complexity and cost.

A 30ppm/°C output temperature coefficient and a 15µA to 20mA operating current range make these voltage references especially attractive for multimeter, data acquisition and telecommunications applications.

PIN CONFIGURATIONS

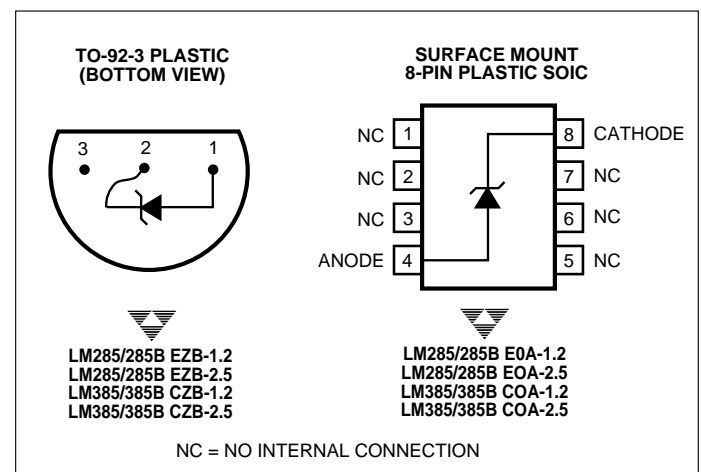

ORDERING INFORMATION

Part No.	Package	Temperature Range	Voltage	Tolerance
LM285BEOA-1.2	8-Pin SOIC	-40°C to +85°C	1.2	1%
LM285BEOA-2.5	8-Pin SOIC	-40°C to +85°C	2.5	1.5%
LM285BEZB-1.2	TO-92-3	-40°C to +85°C	1.2	1%
LM285BEZB-2.5	TO-92-3	-40°C to +85°C	2.5	1.5%
LM285EOA-1.2	8-Pin SOIC	-40°C to +85°C	1.2	2%
LM285EOA-2.5	8-Pin SOIC	-40°C to +85°C	2.5	3%
LM285EZB-1.2	TO-92-3	-40°C to +85°C	1.2	2%
LM285EZB-2.5	TO-92-3	-40°C to +85°C	2.5	3%
LM385BCOA-1.2	8-Pin SOIC	0°C to +70°C	1.2	1%
LM385BCOA-2.5	8-Pin SOIC	0°C to +70°C	2.5	1.5%
LM385BCZB-1.2	TO-92-3	0°C to +70°C	1.2	1%
LM385BCZB-2.5	TO-92-3	0°C to +70°C	2.5	1.5%
LM385COA-1.2	8-Pin SOIC	0°C to +70°C	1.2	2%
LM385COA-2.5	8-Pin SOIC	0°C to +70°C	2.5	3%
LM385CZB-1.2	TO-92-3	0°C to +70°C	1.2	2%
LM385CZB-2.5	TO-92-3	0°C to +70°C	2.5	3%

LOW POWER, BANDGAP VOLTAGE REFERENCES

LM285/285B-1.2V LM285/285B-2.5V LM385/385B-1.2V LM385/385B-2.5V

ABSOLUTE MAXIMUM RATINGS*

Forward Current	+10mA
Reverse Current	+30mA
Storage Temperature Range	- 65°C to +150°C
Operating Temperature Range	
TO-92 Package	- 40°C to +85°C
Surface Mount Package	- 40°C to +85°C

Lead Temperature (Soldering, 10 sec)	
TO-92 Package	+300°C
Surface Mount Package	+300°C
Power Dissipation	
Limited by Forward/Reverse Current	

*Functional operation above the absolute maximum stress ratings is not implied.

ELECTRICAL CHARACTERISTICS: T_A = +25°C, unless otherwise specified.

Symbol	Parameter	Test Conditions	LM285 / LM285B-1.2			LM385 / LM385B-1.2			Unit
			Min	Typ	Max	Min	Typ	Max	
V _{(BR)R}	Reverse Breakdown Voltage LM285B-1.2/LM385B-1.2 T _A = T _{low} to T _{high} (Note 1) LM285-1.2V/LM385-1.2V T _A = T _{low} to T _{high} (Note 1)	I _R ≤ 20mA	1.223	1.235	1.247	1.223	1.235	1.247	V
			1.200	—	1.270	1.210	—	1.260	
			1.205	1.235	1.260	1.205	1.235	1.260	
			1.192	—	1.273	1.192	—	1.273	
I _{RMIN}	Minimum Operating Current T _A = +25°C T _A = T _{low} to T _{high} (Note 1)		—	8.0	15	—	8.0	15	µA
			—	—	20	—	—	20	
ΔV _{(BR)R}	Reverse Breakdown Voltage Change with Current I _{Rmin} = I _R = 1.0mA, T _A = +25°C T _A = T _{low} to T _{high} (Note 1) 1.0mA = I _R = 20mA, T _A = +25°C T _A = T _{low} to T _{high} (Note 1)		—	—	1.0	—	—	1.0	mV
			—	—	1.5	—	—	1.5	
			—	—	10	—	—	20	
			—	—	20	—	—	25	
Z	Reverse Dynamic Impedance	I _R = 100µA	—	0.6	—	—	0.6	—	Ω
ΔV _{(BR)/ΔT}	Average Temperature Coefficient	10µA ≤ I _R ≤ 20mA	—	30	100	—	30	100	ppm/°C
S	Long Term Stability	I _R = 100µA, T _A = +25°C ±0.1°C	—	20	—	—	20	—	ppm/kHR

Symbol	Parameter	Test Conditions	LM285 / LM285B-2.5			LM385 / LM385B-2.5			Unit
			Min	Typ	Max	Min	Typ	Max	
V _{(BR)R}	Reverse Breakdown Voltage LM285B-2.5/LM385B-2.5 T _A = T _{low} to T _{high} (Note 1) LM285-2.5V/LM385-2.5V T _A = T _{low} to T _{high} (Note 1)	I _R = 20mA	2.462	2.5	2.538	2.462	2.5	2.538	V
			2.415	—	2.585	2.436	—	2.564	
			2.425	2.5	2.575	2.425	2.5	2.575	
			2.400	—	2.600	2.400	—	2.600	
I _{RMIN}	Minimum Operating Current T _A = +25°C T _A = T _{low} to T _{high} (Note 1)		—	13	20	—	13	20	µA
			—	—	30	—	—	30	
ΔV _{(BR)R}	Reverse Breakdown Voltage Change with Current I _{Rmin} = I _R = 1.0mA, T _A = +25°C T _A = T _{low} to T _{high} (Note 1) 1.0mA = I _R = 20mA, T _A = +25°C T _A = T _{low} to T _{high} (Note 1)		—	—	1.0	—	—	2.0	mV
			—	—	1.5	—	—	2.5	
			—	—	10	—	—	20	
			—	—	20	—	—	25	
Z	Reverse Dynamic Impedance	I _R = 100µA	—	0.6	—	—	0.6	—	Ω
ΔV _{(BR)/ΔT}	Average Temperature Coefficient	20µA ≤ I _R ≤ 20mA	—	30	100	—	30	100	ppm/°C
S	Long Term Stability	I _R = 100µA, T _A = +25°C ±0.1°C	—	20	—	—	20	—	ppm/kHR

Note: 1. T_{low} = - 40°C for LM285-1.2, LM285-2.5, LM285B-1.2, LM285B-2.5
0°C for LM385-1.2, LM385B-1.2, LM385-2.5, LM385B-2.5
T_{high} = +85°C for LM285-1.2, LM285-2.5, LM285B-1.2, LM285B-2.5
+70°C for LM385-1.2, LM385B-1.2, LM385-2.5, LM385B-2.5

LOW POWER, BANDGAP VOLTAGE REFERENCES

LM285/285B-1.2V
LM285/285B-2.5V
LM385/385B-1.2V
LM385/385B-2.5V

TYPICAL APPLICATIONS

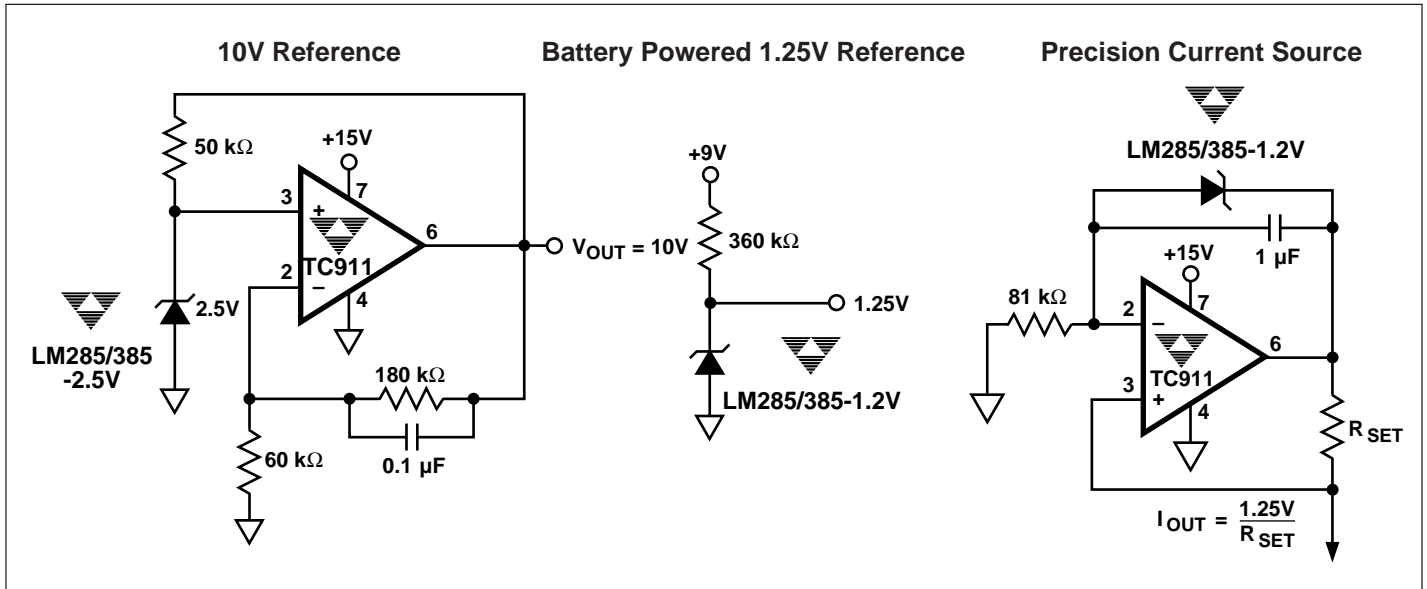

3

RESPONSE TIME TEST CIRCUIT

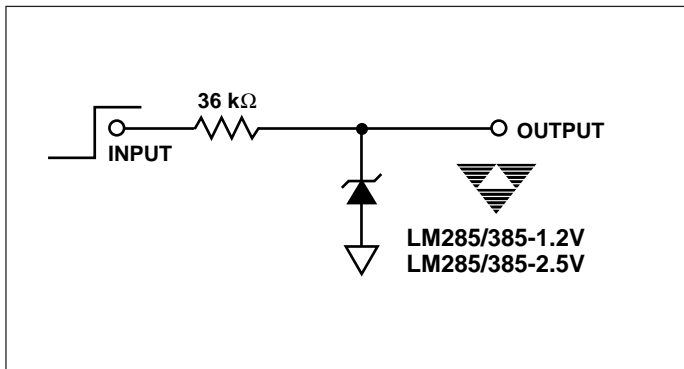

TYPICAL CHARACTERISTICS

