



M.S.KENNEDY CORP.

**100 VOLT 10 AMP RAD-HARD
H-BRIDGE PWM MOTOR
DRIVER/AMPLIFIER**

4204RH

4707 Dey Road Liverpool, N.Y. 13088

(315) 701-6751

FEATURES:

- Total Dose Hardened To TBD Krad(Si) (Method 1019.8 Condition A)
- 100 Volt, 10 Amp Capability
- Self-Contained Smart Lowside/Highside Drive Circuitry
- Internal PWM Generation, Shoot-through Protection
- Isolated Case Allows Direct Heatsinking
- Available Fully Screened To MIL-PRF-38534 Class K and Class H
- Output Stage Includes Blocking and Reverse Diodes
- Contact MSK for MIL-PRF-38534 Qualification and Appendix G (Radiation Status)

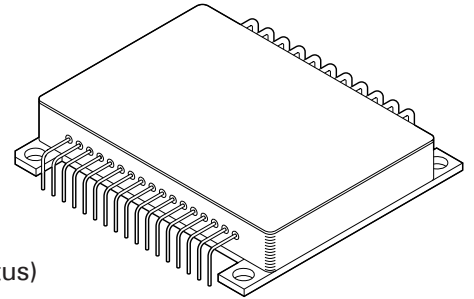

DESCRIPTION:

The MSK 4204RH is a radiation hardened complete H-Bridge microcircuit intended for use in DC brushed motor control applications or Class D switchmode amplification in space or other severe operating environments. The internal components have been selected to provide total dose up to 300K RAD for military and space applications. All of the drive/control circuitry for the lowside and highside switches are internal to the device. The PWM circuitry is internal as well, leaving the user to only provide an analog signal for the motor speed/direction, or audio signal for switchmode audio amplification. If 100% duty cycle is required, access to the high-side bias has been provided. With the addition of two isolated power supplies 100% duty cycle is possible. The MSK 4204RH is packaged in a space efficient isolated power package, available in three lead form configurations that can be directly connected to a heatsink.

EQUIVALENT SCHEMATIC

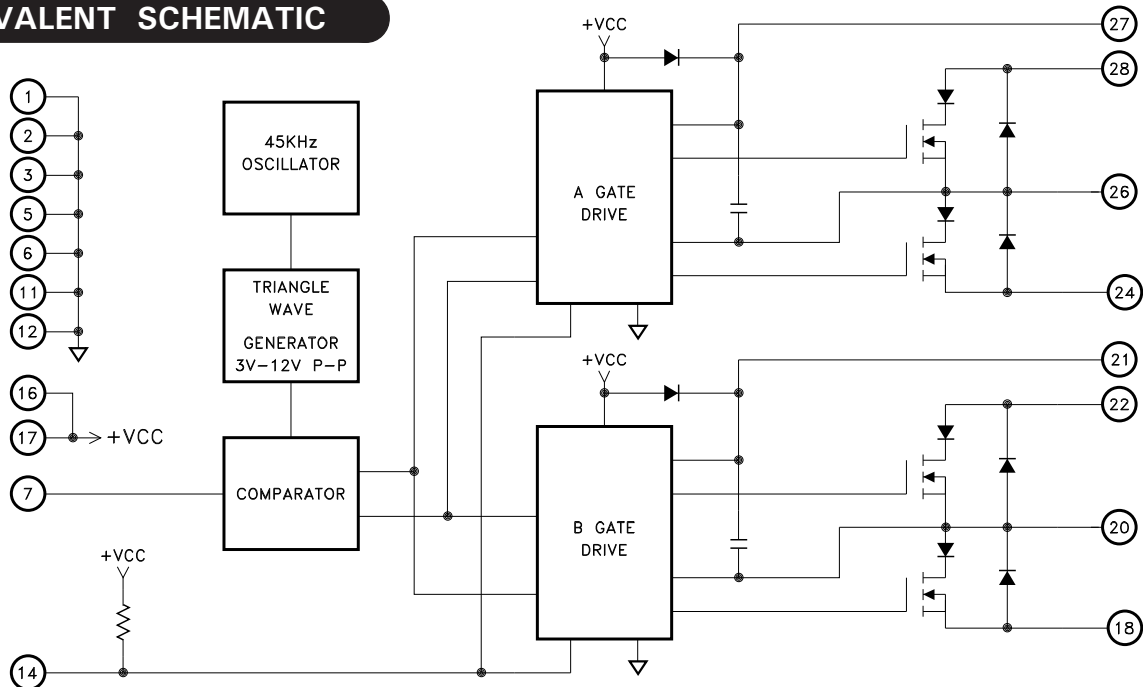

TYPICAL APPLICATIONS

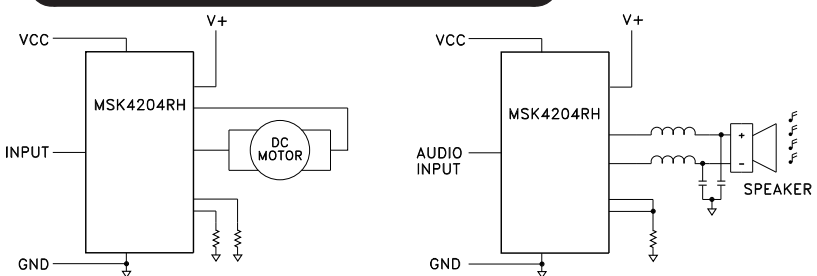

PIN-OUT INFORMATION

1 GND	8 NC	15 NC	22 BV +
2 GND	9 NC	16 +VCC	23 NC
3 GND	10 NC	17 +VCC	24 AV-
4 NC	11 GND	18 BV-	25 NC
5 GND	12 GND	19 NC	26 AØ
6 GND	13 NC	20 BØ	27 AVB
7 INPUT	14 SHUTDOWN	21 BV B	28 AV +

ABSOLUTE MAXIMUM RATINGS ^⑧

V+	High Voltage Supply	100V	T _{ST}	Storage Temperature Range	-65°C to +150°C
V _{CC}	Logic Supply	20V	T _{LD}	Lead Temperature Range (10 Seconds)	300°C
I _{OUT}	Continuous Output Current	10A	T _C	Case Operating Temperature	MSK 4204 K/H RH. -55°C to +125°C
I _{PK}	Peak Output Current	20A		MSK 4204 RH.	-40°C to +85°C
V _{OUT}	Output Voltage Range	GND-5V min. to V+ max.	T _J	Junction Temperature	+150°C
V _{IN}	Input Voltage	V _{CC}	θ _{Jc}	Thermal Resistance	(Output FETS @ 125°C). 2.5°C/W
V _L	Logic Input Voltage (Shutdown)	0V to V _{CC}		(Output Diodes @ 125°C).	3.2°C/W
V _B	High-Side Bias	20V			

ELECTRICAL SPECIFICATIONS

Parameter	Test Conditions ^①	Group A Subgroup ^④	MSK 4204RH ^③			Units
			Min.	Typ.	Max.	
OUTPUT CHARACTERISTICS						
V _{DS(ON)} Voltage (Diode plus MOSFET)	ID = 10A	1	-	1.5	2.0	V
	ID = 8.6A	2	-	1.7	2.5	V
	ID = 10A	3	-	1.4	2.0	V
Instantaneous Forward Voltage	IS = 10A	1	-	1.0	1.3	V
		2	-	0.9	1.2	V
		3	-	1.1	1.3	V
R _{DS(ON)} each MOSFET ^② ^⑦	ID = 10A TC = 25°C	-	-	0.06	0.1	Ω
Leakage Current, each MOSFET	V+ = 80V	1	-	0.1	25	uA
		2	-	15	250	uA
		3	-	0.1	25	uA
PWM Frequency		4,5,6	40	45	50	KHz
VCC SUPPLY CHARACTERISTICS						
Quiescent Current	V _{IN} = 7.5V	1,2,3	-	16	22	mA
UVLO	V _{CC} Increasing	1	7.5	8.5	9.7	V
	V _{CC} Decreasing	1	7.0	8.0	9.4	V
OUTPUT DUTY CYCLE						
	V _{IN} = 7.5V Both Outputs Tested	4,5,6	40	-	60	%
	V _{IN} = 15V Output A = 0% Duty Cycle Output B = 100% Duty Cycle	7	-	Verify	-	P/F
	V _{IN} = 0V Output A = 100% Duty Cycle Output B = 0% Duty Cycle	7	-	Verify	-	P/F
SWITCHING CHARACTERISTICS						
Rise Time ^②	RL = 1K A to B	4	-	20	100	nS
Fall Time ^②	RL = 1k A to B	4	-	20	100	nS
LOGIC CONTROL INPUTS						
Shutdown Input	Input Voltage LO	1,2,3	-	-	5.7	V
	Input Voltage HI	1,2,3	10.0	-	-	V
	Input Current (Low) V _{IN} = 0V	1,2,3	-	1.0	1.3	mA
	Input Current (High) V _{IN} = +V _{CC}	1,2,3	-	33	100	uA

NOTES:

- ① V_{CC} = 15V, V+ = 28V, AV-, BV- = Ground, Shutdown = 0V unless otherwise specified.
- ② Guaranteed by design but not tested. Typical parameters are representative of actual device performance but are for reference only.
- ③ Industrial grade devices shall be tested to Subgroups 1, 4 and 7 unless otherwise requested.
- ④ Military and Space grade devices ("H" and "K") shall be 100% tested to subgroups 1,2,3,4,5,6 and 7.
- ⑤ Subgroup 1,4,7 TA = Tc = +25°C
2,5 TA = Tc = +125°C
3,6 TA = Tc = -55°C
- ⑥ Industrial grade and devices shall be 100% tested at 25°C only.
- ⑦ The internal on resistance is for the die only. This should be used for thermal calculations only.
- ⑧ Continuous operation at or above absolute maximum ratings may adversely effect the device performance and/or life cycle.
- ⑨ Pre and post irradiation limits @ 25°C, up to TBD Krad, are identical unless otherwise specified.

APPLICATION NOTES

MSK 4204RH PIN DESCRIPTIONS

+VCC - Is the low voltage supply for powering internal logic and drivers for the lowside and highside MOSFETS. The supplies for the highside drivers are derived from this voltage. Optimum operation occurs with Vcc set at 15V.

AV +, BV + - Are the high voltage H-bridge supply pins. The MOSFETS obtain the drive current from these supply pins. The MOSFETS are rated at 100 volts. Proper bypassing to GND with sufficient capacitance to suppress any voltage transients, and ensure removal of any drooping during switching, should be done as close to the pins on the hybrid as possible.

AØ - Are the output pins for one half of the bridge. Increasing the input voltage causes increasing duty cycles at this output.

BØ - Are the output pins for the other half of the bridge. Decreasing the input voltage causes increasing duty cycles at this output.

AVB & BVB - Are the high-side bias pins. Some applications require that the high-side be on for an indefinite period of time. Under these conditions the charge in the boost capacitor will not be adequate to keep the high-side output on. If continuous on time is required, external floating power supplies must be connected to the AVB and BVB pins to power the high-side drive. Blocking diodes should be used to prevent Vcc from sourcing current to the floating supply should Vcc rise above the floating supply level. Reference typical system operation schematic. If not used, the high-side bias pins must remain high impedance.

AV- - Are the connections for the bottom of the A half bridge. This can have a sense resistor connection to the V + return ground for current limit sensing, or can be connected directly to ground. The maximum voltage on these pins is ± 5 volts with respect to GND.

BV- - Are the connections for the bottom of the B half bridge. This can have a sense resistor connection to the V + return ground for current limit sensing, or can be connected directly to ground. The maximum voltage on these pins is ± 5 volts with respect to GND.

GND - Is the return connection for the input logic and Vcc.

INPUT - Is an analog input for controlling the PWM pulse width of the bridge. A voltage higher than 7.5V will produce greater than 50% duty cycle pulses out of OUTPUT B. A voltage lower than 7.5V will produce greater than 50% duty cycle pulses out of OUTPUT A.

SHUTDOWN - Is the connection for disabling all 4 output switches. SHUTDOWN high overrides all other inputs. When taken low, everything functions normally. An internal pullup to Vcc will keep SHUTDOWN high if left unconnected. This pin should be grounded if not used.

UVLO - The under voltage lockout function of the MSK 4204RH prevents the device from starting before sufficient bias voltage is available. The UVLO feature monitors the VCC supply and holds the outputs low until the voltage level rises above the threshold during start up. After start up the low side UVLO circuit will hold the low side switches off if VCC falls below the threshold. The high side UVLO circuit will hold the high side switches off any time the voltage on the bootstrap capacitor falls below the threshold.

MAXIMUM DUTY CYCLE AND HIGH SIDE BIAS - The MSK 4204RH uses two independent bootstrap circuits to power each of the high side switches. When the switches are turned on the high side drivers are powered by the charge in the bootstrap capacitors. The voltage on the bootstrap capacitors has an initial 40mV drop and decays at a rate of approximately 0.23V every 100uS. The voltage can be approximated by the equation:

$$V_{BS} = +V_{CC} - 0.64V - 2.3 \times T_{ON}$$

TON is the switch on time in mS
VBS is the bootstrap capacitor voltage

VBS should be greater or equal to 10 volts to ensure that VBS does not drop below the UVLO threshold.

TOTAL DOSE RADIATION TEST PERFORMANCE

Radiation performance curves for TID testing will be generated for all radiation testing performed by MS Kennedy. These curves show performance trends throughout the TID test process and can be located in the MSK 4204RH radiation test report. The complete radiation test report will be available in the RAD HARD PRODUCTS section on the MSK website.

<http://www.mskennedy.com/store.asp?pid=9951&catid=19680>

RADIATION PERFORMANCE CURVES

SAFE OPERATING AREA
SWITCH CURRENT vs CASE TEMPERATURE

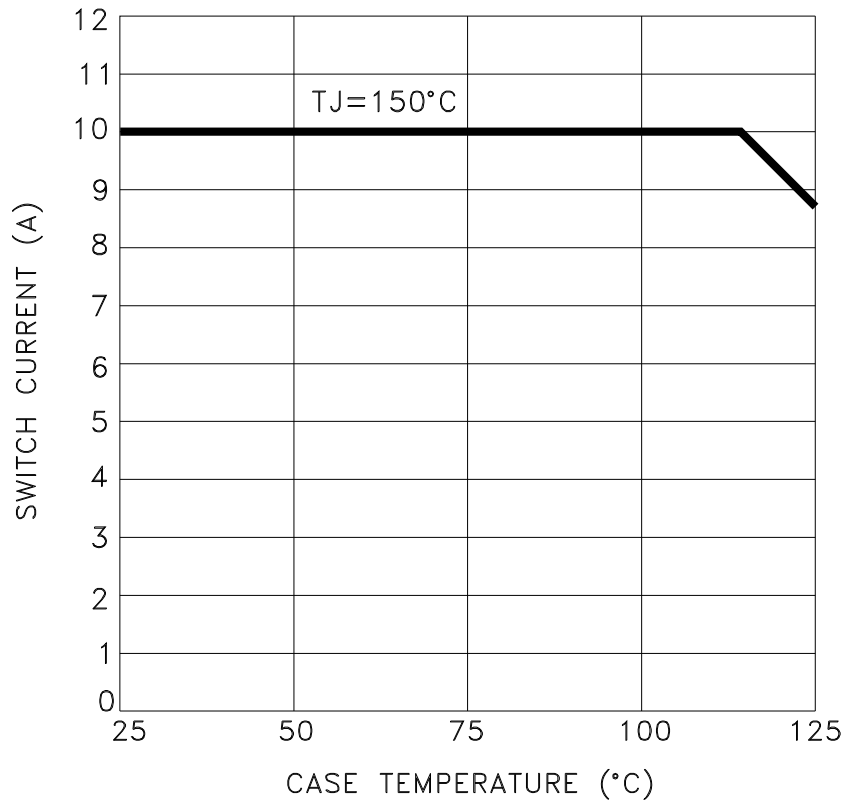

TYPICAL SYSTEM OPERATION

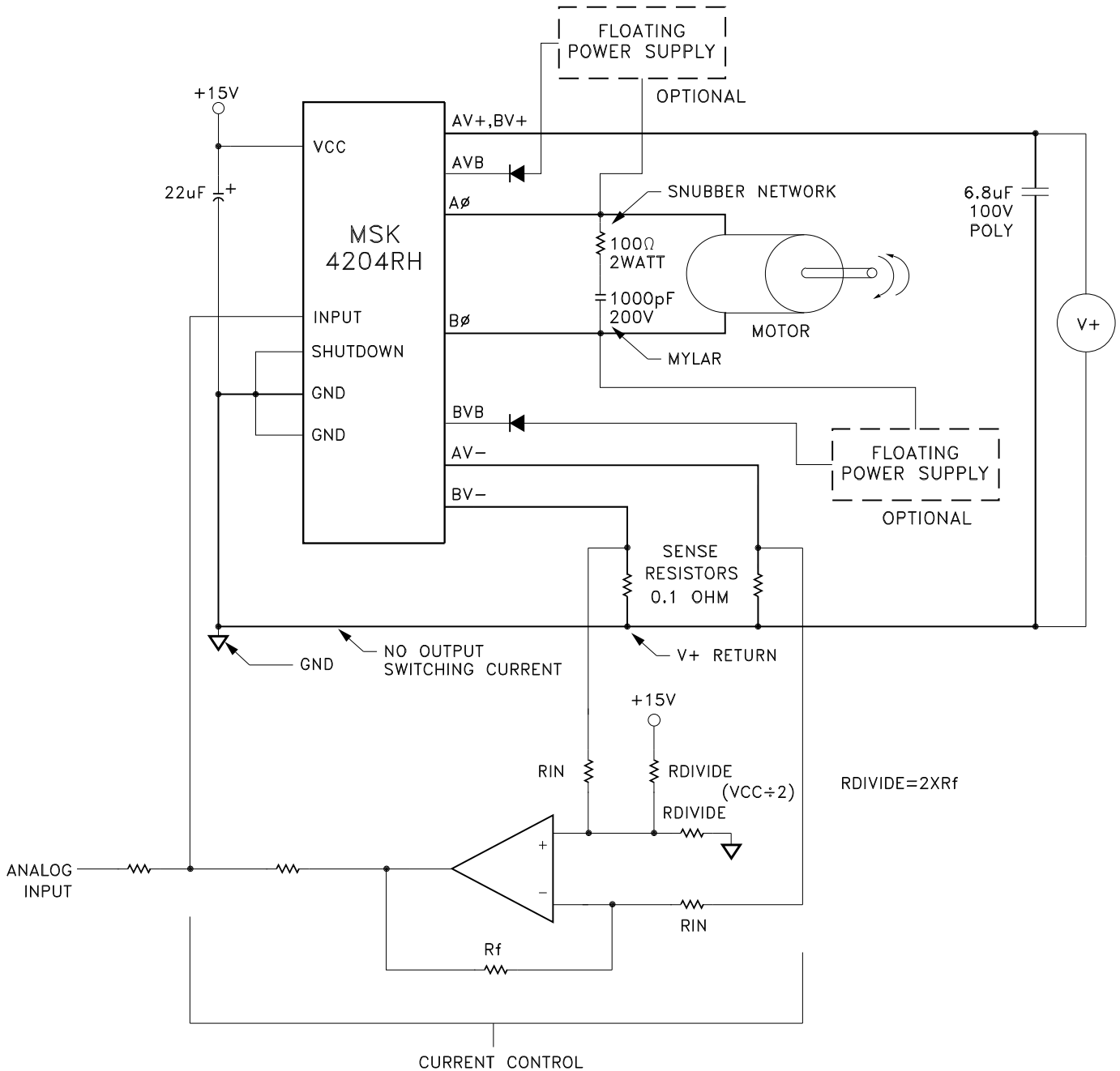

This is a diagram of a typical application of the MSK 4204RH. The design Vcc voltage is + 15 volts and should have a good low ESR bypass capacitor such as a tantalum. The analog input can be an analog speed control voltage from a potentiometer, other analog circuitry or by microprocessor and a D/A converter. This analog input gets pulled by the current control circuitry in the proper direction to reduce the current flow in the bridge if it gets too high. The gain of the current control amplifier will have to be set to obtain the proper amount of current limiting required by the system.

Current sensing is done in this case by a 0.1 ohm sense resistor to sense current from both legs of the bridge separately. It is important to make the high current traces as big as possible to keep inductance down. The storage capacitor connected to the V + and the hybrid should be large enough to provide the high energy pulse without the voltage sagging too far. A low ESR ceramic capacitor or large polypropylene capacitor will be required. Mount capacitor as close to hybrid as possible. The connection between GND and the V + return should not be carrying any motor current. The sense resistor signal is common mode filtered as necessary to feed the limiting circuitry for the microprocessor. This application will allow full four quadrant torque control for a closed loop servo system.

A snubber network is usually required, due to the inductance in the power loop. It is important to design the snubber network to suppress any positive spikes above 100V and negative spikes below -4V with respect to GROUND.

MECHANICAL SPECIFICATIONS

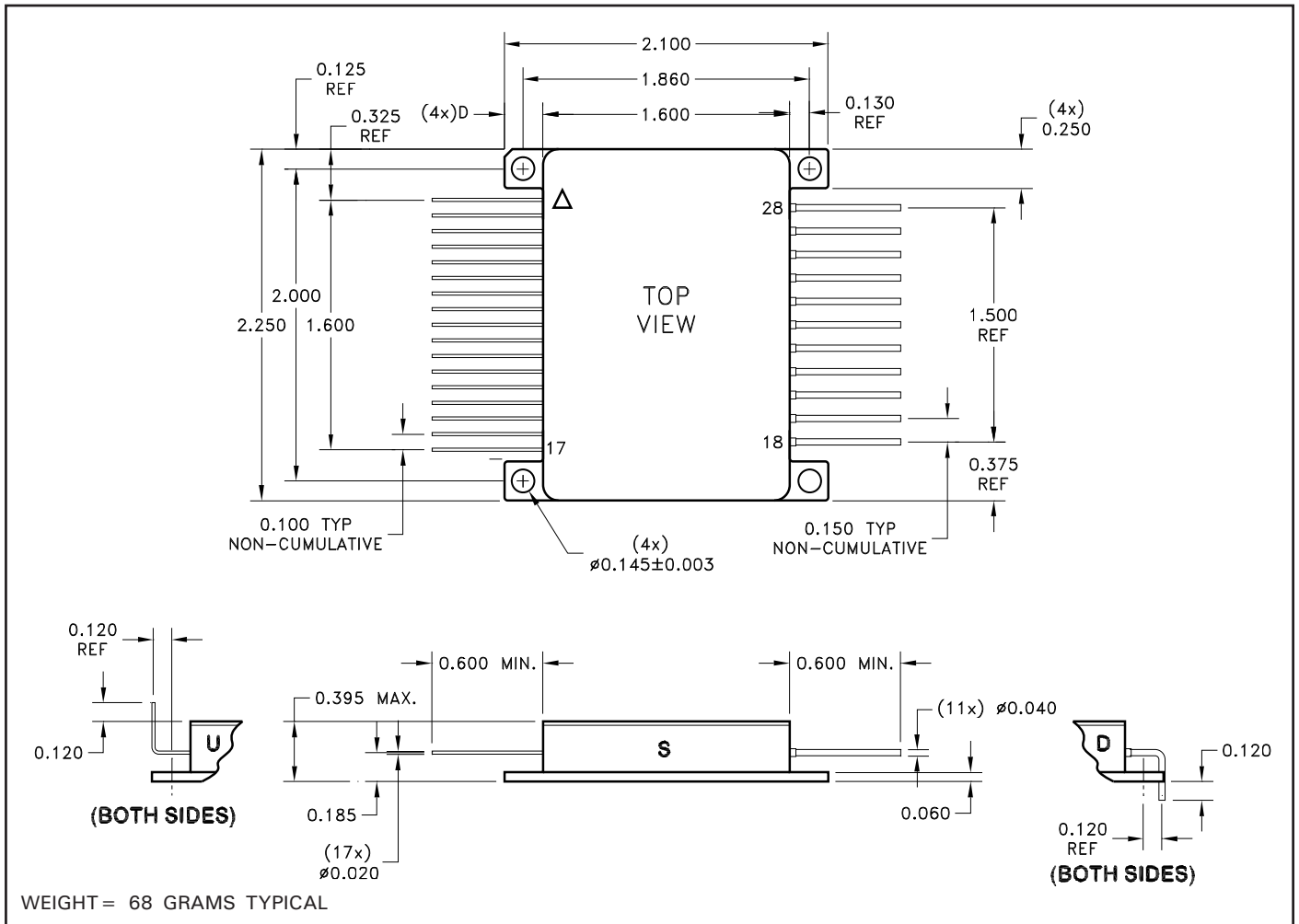

ESD Triangle indicates Pin 1.

ALL DIMENSIONS ARE ± 0.01 INCHES UNLESS OTHERWISE LABELED

ORDERING INFORMATION

MSK4204 H RH U

LEAD CONFIGURATIONS

S = STRAIGHT; U = BENT UP; D = BENT DOWN

RADIATION HARDENED

SCREENING

BLANK = INDUSTRIAL; H = MIL-PRF-38534 CLASS H;

K = MIL-PRF-38534 CLASS K

GENERAL PART NUMBER

The above example is a Military grade class H hybrid with leads bent up.

M.S. Kennedy Corp.

4707 Dey Road, Liverpool, N.Y. 13088

Phone (315) 701-6751

FAX (315) 701-6752

www.mskennedy.com

The information contained herein is believed to be accurate at the time of printing. MSK reserves the right to make changes to its products or specifications without notice, however, and assumes no liability for the use of its products.

Please visit our website for the most recent revision of this datasheet.

Contact MSK for MIL-PRF-38534 Class H, Class K qualification and Appendix G (radiation) status.