

D*-N/D*-UL SOLDER TYPE

D*-N/D*-UL Standard Type

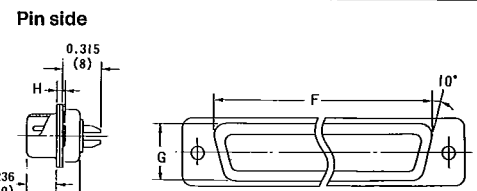

Dimensions when mated

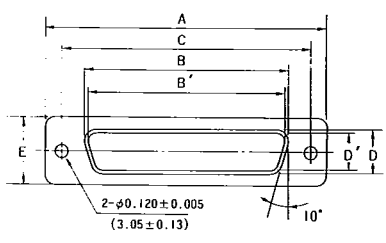
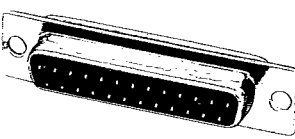
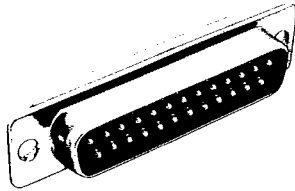
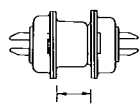

DE, DA...6.2
DB, DC, DD...6.0

Socket side

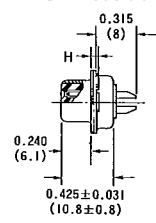

Note: Dimensions B and D are the outer dimensions of the shell of the socket connector. Dimensions B' and D' represent the inner dimensions of the pin connector.

D*-N/D*-UL Float Mount

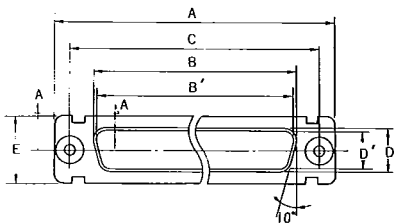
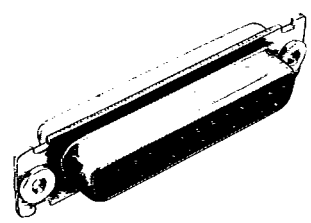

Floating rivet (A-A)

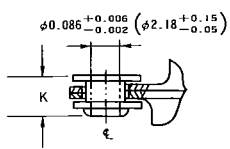

Pin side

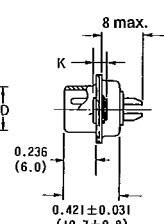

Socket side

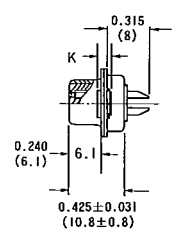

Note: The floating washer moves 0.4 mm in any direction with regards to the center (c). Only one of the mating connectors should be float mounted.

No. of Contacts	Contact Type	Part Number		A	B	B'	C	D	D'	E	F	G	H	K
		Stamped Contact	Machined Contact	±.020 (±0.5)	±.010 (±0.25)	±.010 (±0.25)	±.005 (±0.13)	±.010 (±0.25)	±.010 (±0.25)	±.020 (±0.5)	±.016 (±0.4)	±.016 (±0.4)	±.016 (±0.4)	±.010 (±0.25)
9	Pin	DE-9P-N	DE-9P-UL	1.213 (30.8)	—	.665 (16.90)	.984 (24.99)	—	.328 (8.34)	.496 (12.6)	.760 (19.3)	.421 (10.7)	.047 (1.2)	.120 (3.05)
	Socket	DE-9S-N	DE-9S-UL	1.213 (30.8)	.640 (16.26)	—	.984 (24.99)	.308 (7.82)	—	.496 (12.6)	.760 (19.3)	.421 (10.7)	.047 (1.2)	.120 (3.05)
15	Pin	DA-15P-N	DA-15P-UL	1.539 (39.1)	—	.994 (25.24)	1.312 (33.32)	—	.328 (8.34)	.496 (12.6)	1.083 (27.5)	.421 (10.7)	.047 (1.2)	.120 (3.05)
	Socket	DA-15S-N	DA-15S-UL	1.539 (39.1)	.968 (24.59)	—	1.312 (33.32)	.308 (7.82)	—	.496 (12.6)	1.083 (27.5)	.421 (10.7)	.047 (1.2)	.120 (3.05)
25	Pin	DB-25P-N	DB-25P-UL	2.087 (53.0)	—	1.536 (39.01)	1.852 (47.04)	—	.331 (8.40)	.496 (12.6)	1.626 (41.3)	.421 (10.7)	.059 (1.5)	.129 (3.28)
	Socket	DB-25S-N	DB-25S-UL	2.087 (53.0)	1.508 (38.30)	—	1.852 (47.04)	.308 (7.82)	—	.496 (12.6)	1.626 (41.3)	.421 (10.7)	.047 (1.2)	.120 (3.05)
37	Pin	DC-37P-N	DC-37P-UL	2.728 (69.3)	—	2.184 (55.47)	2.500 (63.50)	—	.331 (8.40)	.496 (12.6)	2.272 (57.7)	.421 (10.7)	.059 (1.5)	.129 (3.28)
	Socket	DC-37S-N	DC-37S-UL	2.728 (69.3)	2.156 (54.76)	—	2.500 (63.50)	.308 (7.82)	—	.496 (12.6)	2.272 (57.7)	.421 (10.7)	.047 (1.2)	.120 (3.05)
50	Pin	DD-50P-N	DD-50P-UL	2.634 (66.9)	—	2.081 (52.86)	2.406 (61.11)	—	.439 (11.16)	.606 (15.4)	2.177 (55.3)	.547 (13.9)	.059 (1.5)	.129 (3.28)
	Socket	DD-50S-N	DD-50S-UL	2.634 (66.9)	2.061 (52.34)	—	2.406 (61.11)	.419 (10.65)	—	.606 (15.4)	2.177 (55.3)	.547 (13.9)	.047 (1.2)	.120 (3.05)

Notes: (1) To order float mount type, add "F" after the shell size code (e.g. DAF-15S-N, and DCF-37P-UL).
(2) To order Original-D Sub miniature connectors with machined contacts and glass-filled nylon insulator delete "-N" or "-UL" from the end of the part description (e.g. DE-9P and DB-25S).

FEATURES

• **Five different shell sizes and numbers of conductors**

The connector housing is compact and rectangular. The contacts and insulators are contained in a rugged steel shell. There are five shell sizes (E, A, B, C, and D), respectively with standard contact counts of 9, 15, 25, 37, and 50. Special layouts to accept coaxial, high-voltage, and high-current contacts are also available.

E	A	Shell Size:
9	15	Number of Conductors:

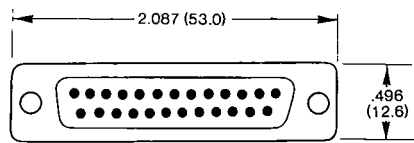
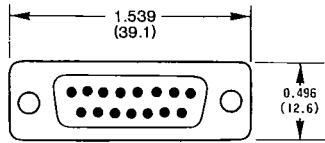
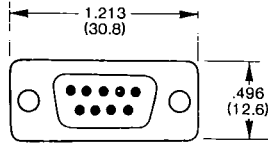

B	Shell Size:
25	Number of Conductors:

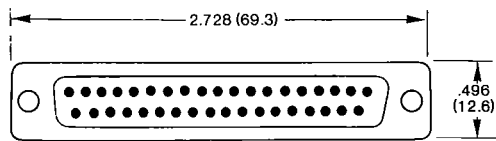

C	Shell Size:
37	Number of Conductors:

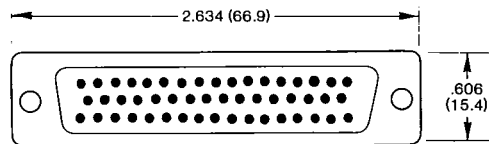

D	Shell Size:
50	Number of Conductors:

Special Layouts (D*M Type)



• **Fail-Safe Polarizing Mechanism**

The shell connecting part is keystone trapezoidal which inherently prevents incorrect coupling.

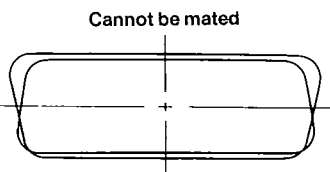
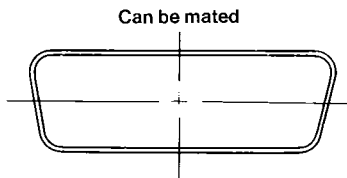

• **Official Standards**

D Sub connectors conform to many international standards including:

- Japan Industrial Standards
 - JIS-C-6361
 - JIS-C-6366
 - JIS-C-6367
- Japan Defense Agency Standards
 - NDSXC 6116
 - DSP C 6242
- US Military Standards
 - MIL-C-24308

• **Shell Type**

The shell profile comes in a panel-mounting standard type and floating type (the latter aids in rack-to-panel connection).

A-17-03
A-17-05
A-61-11
A-65-07

Standard Type

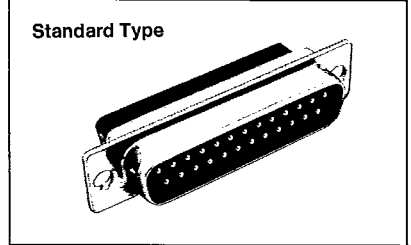

Floating Type

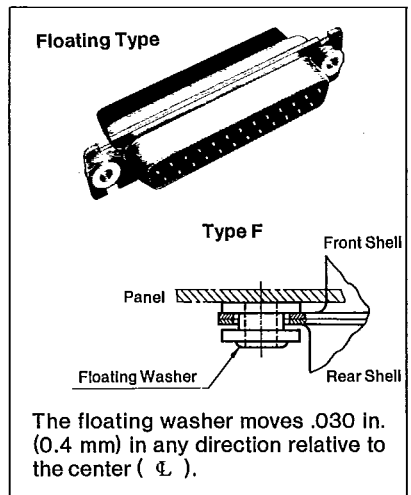

The floating washer moves .030 in. (0.4 mm) in any direction relative to the center (⌀).

• **Close Entry Construction**

Socket insulators have a closed entry construction which prevents entry of oversized contacts or probes.

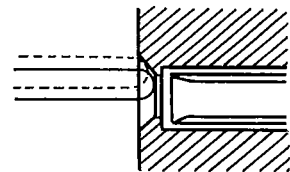

• **Compatibility**

Individual connector types are interchangeable as are the accessories.

■ General Specification (Principal Performance)

Division	Item	Performance						
		D *		D * M	D * U			
		Stamped Contacts	Machined Contacts		Stamped Contacts		Machined	
Electrical Performance	Rated Current	5A						
	Dielectric Strength (See Level)	AC 1250 V r.m.s			AC 1000 V r.m.s			
	Insulation Resistance	5000 M-ohm or greater						
	Contact Resistance	2.7 m-ohm or less (5.0 m-ohm or less after the life and after salt spray). Test current: AWG No. 20, 7.5 a; AWG No. 22, 5; AWG No. 24, 3. *Through hole (PCB mounted connectors not applicable).						
Mechanical Performance	Contact Force	Mating force: 28.4 ~ 408 g Unmating force: 28.4 ~ 272 g	Mating force: 28.4 ~ 340 g Unmating force: 28.4 ~ 227 g	Mating force: 28.4 ~ 408 g Unmating force: 28.4 ~ 272 g				
	Connector Mating/Unmating Force	Mating force: (408 g × number of contacts) or less. Unmating force: (272 g × number of contacts) or less.	Mating force: (340 g × number of contacts) or less. Unmating force: (227 g × number of contacts) or less.	kg or less	Stamped Contact		Machined	
					Mating Force	Unmating Force	Mating Force	
					9	3.7	2.4	3.1
					15	6.1	4.1	5.1
25					10.2	6.8	8.5	
37	15.1	10.1	12.6					
50	20.4	13.6	17.0					
Contact Retention Force (kg or larger)	D *		D * M	D * U				
	Stamped Contacts	Machined Contacts		Stamped Contacts		Machined		
	4.5		4.1	3.6		4.5		
Vibrations	(1) The current (discontinuity) shall not exceed one (1) microsecond. (2) Shall pass the dielectric strength test at sea level. (3) Parts shall be free of cracks, damage, and looseness.							

A-17-03
 A-17-05
 A-61-11
 A-65-07

■ General Specification (Principal Performance)

Division	Item	Performance			
		D*		D* M	Stamped Contact
		Stamped Contact	Machined Contact		
Mechanical Performance	Contact Retention Force (kg or larger)	4.5		4.1	3.6
	Shock	(1) Current discontinuity may not exceed one (1) microsecond during the test. (2) Shall pass the dielectric strength test at sea level. (3) Parts shall be free of cracks, damage, and looseness.			
	Life	(1) Contact resistance 5 m-ohm or less. (D* SP: 30 m-ohm or less.) (2) Contact mating/unmating force Refer to the previous section. (3) Connector mating/unmating force			
Environmental Performance	Temperature Cycle		D*	D* M	
		Low Temperature	-67°F (-55°C)	-85°F (-65°C)	
		High Temperature	+257°F (+125°C)	+302°F (+150°C)	
		(1) The connector shall be free of cracks and damage. (2) Shall pass the dielectric strength test at sea level.			
	Humidity Resistance	Immediately after test (1) Insulation resistance: 1 M-ohm or higher. (2) Dielectric strength: 600 VAC rms or higher. (D* SP: 400 VAC rms or higher.) After storing for 24 hours (1) Insulation resistance: 1000 M-ohm or higher.			
Corrosion	(1) There shall be no detrimental corrosion that affects the base metal and connector (2) Contact resistance: 5 m-ohm or less. (D* SP: 30 m-ohm or less.)				

SOLDER TYPE

D*-N/D*-UL TYPE

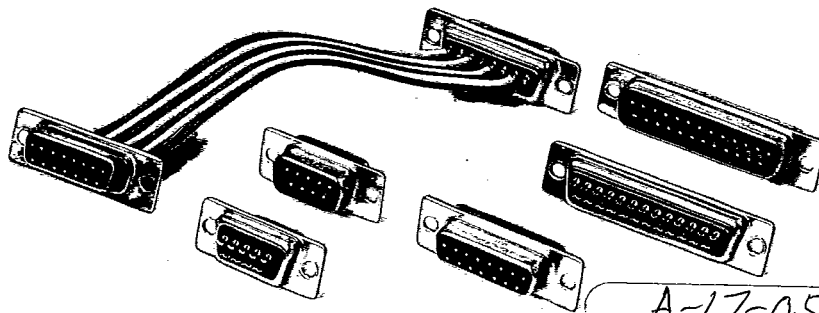

A-17-05

HOW TO ORDER

DA -15P-N DBF-25S-UL

- **Modification codes**
 N Stamped contacts (Insulator material UL listed)
 UL Machined contacts (Insulator material UL listed)
 No designator Machined contacts (Insulator material: glass filled nylon)

- **Contact type:** P ... Pin; S ... Socket

- **Contact arrangements:** 9, 15, 25, 37, 50

- **Mounting type:** No designator Standard
 F ... Floating type (rear mounting)

- **Shell Size:** E, A, B, C, D

- **Series Prefix**

FEATURES

- Solder termination connectors with standard contacts (size No. 20, rated current 5 A) with a solder pots.
- Machined (D*-UL type) and stamped (D*-N type) contacts are available. The insulators are UL94V-O polyester. Connectors with machined contacts are optionally available with glass-filled nylon (D*-part numbering without the -N or -UL callouts).
- Easy-to-use, economical products.
- Five shell sizes (E, A, B, C, and D) are supplied with 9, 15, 25, 37, or 50 conductors.
- **Wire size**
 For 20 AWG and smaller wires when soldering the iron capacity should be less than 40 W.

STANDARD DATA

• Materials/Finishes

Component	Material	Finish
Contact	Copper alloy	Gold plate
Insulator	Glass-filled polyester	UL94V-O Color: Black
Shell	Steel	Yellow chromate over zinc plate

• Electrical Performance (DATA)

Current Rating	5 amp
Dielectric Rating	1250 V AC r.m.s
Insulation Resistance	5000 M-ohm or greater
Contact Resistance	2.7 m-ohm or less

- For details, see pages 6 and 7.
- For terminating and assembling methods, see page 60 thru 62.

CONTACT ARRANGEMENTS

Face view of pin inserts

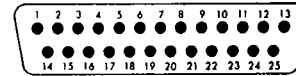
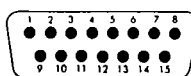
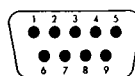

Shell size	E	A	B
Contact arrangements	9	15	25

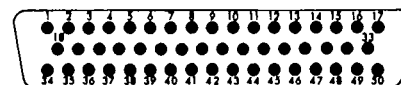
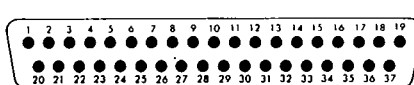

Shell size	C	D
Contact arrangements	37	50