

## OVERVIEW

The CF1155 series are CMOS melody LSIs that, together with a battery and piezoelectric buzzer, operate in one of 3 melody modes determined by input level or bonding options. They also feature an oscillator stop function in non-play mode and a variable pull-down resistance function that responds to input levels in order to reduce power consumption, reduce cost, and extend battery life, making them ideal in a wide range of applications including greeting cards and toys.

## FEATURES

- Requires few external components
- 1.2 to 3.6V wide operating voltage range
- Low power consumption
- 3 melody modes (bonding option)
- Oscillator stop function in non-play mode
- Power saving pull-down resistor built-in
- RC oscillator circuit
- Power-ON initialization function
- 2 V<sub>SS</sub> pad connections
- Wide pitch dynamic range (G<sub>3</sub> to D<sub>7</sub>)
- Chip form

## PAD LAYOUT and COORDINATES

(Unit: μm)

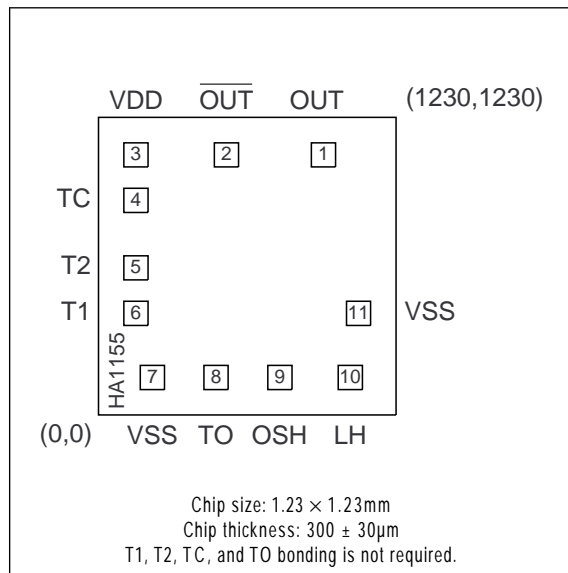

Number	Pad	X	Y
1	OUT	930	1075
2	OUT	529	1075
3	VDD	155	1075
4	TC	155	887
5	T2	155	608
6	T1	155	420
7	VSS	223	155
8	TO	486	155
9	OSH	750	155
10	LH	1041	155
11	VSS	1075	420

## ORDERING INFORMATION

Device	Package
CF1155	Chip form

## PAD DESCRIPTION

Name	Function
OSH, LH	Melody mode control inputs. Built-in pull-down resistors mean LOW-level signals are obtained when inputs are open circuit. The resistance of the pull-down resistor varies with the applied voltage, as described in the Electrical Characteristics.
OUT, $\overline{\text{OUT}}$	Piezoelectric speaker driver outputs. Both pins are LOW in non-play mode. OUT is LOW and $\overline{\text{OUT}}$ is HIGH during output for a musical rest note. Both pins are HIGH during the gap between musical notes.
VDD	Supply. The rear surface of the chip is $V_{DD}$ level.
VSS	Ground
T1, T2, TC	Test inputs. Pull-down resistor built-in.
TO	Test output. The oscillator frequency (typ. 50kHz) is output for monitoring purposes.

## SPECIFICATIONS

### Absolute Maximum Ratings

Parameter	Symbol	Condition	Rating	Unit
Supply voltage range	$V_{DD} - V_{SS}$		-0.3 to 5.0	V
Input voltage range	$V_{IN}$		$V_{SS} - 0.2$ to $V_{DD} + 0.2$	V
Operating temperature range	$T_{opr}$		-20 to 80	°C
Storage temperature range	$T_{stg}$		-65 to 150	°C

### Electrical Characteristics

$T_a = 25^\circ\text{C}$ ,  $V_{SS} = 0\text{V}$ ,  $V_{DD} = 1.5\text{V}$

Parameter	Symbol	Condition	Rating			Unit
			min	typ	max	
Operating voltage	$V_{DD}$		1.2	1.5	3.6	V
Current consumption <sup>1</sup>	$I_{DD1}$	Non-play mode	-	0.01	0.3	$\mu\text{A}$
Current consumption <sup>2</sup>	$I_{DD2}$	Melody modes: OUT, $\overline{\text{OUT}}$ open	-	25	50	$\mu\text{A}$
LH, OSH LOW-level input voltage	$V_{IL}$		-	-	$V_{SS} + 0.2$	V
LH, OSH HIGH-level input voltage	$V_{IH}$		$V_{DD} - 0.2$	-	-	V
LH, OSH LOW-level input current	$I_{IL}$	$V_{IL} = 0.4\text{V}$	0.7	1.5	3.0	$\mu\text{A}$
LH, OSH HIGH-level input current	$I_{IH}$	$V_{IH} = 1.5\text{V}$	0.7	1.5	3.0	$\mu\text{A}$
OUT, $\overline{\text{OUT}}$ LOW-level output current	$I_{OL}$	$V_{OL} = 0.75\text{V}$	2.0	-	-	mA
OUT, $\overline{\text{OUT}}$ HIGH-level output current	$I_{OH}$	$V_{OH} = 0.75\text{V}$	2.0	-	-	mA
TO oscillator frequency	$f_{osc}$		35	50	65	kHz
TO frequency stability (relative to voltage)	$\Delta f/f_1$	$V_{DD} = 1.2$ to $2.0\text{V}$	-	1	-	%/0.1V
	$\Delta f/f_2$	$V_{DD} > 2.0\text{V}$	-	2	-	%/1V
TO oscillator start voltage	$V_{DOB}$		-	-	1.2	V
TO oscillator stop voltage	$V_{DOS}$		-	-	1.2	V

1. Measurement circuit

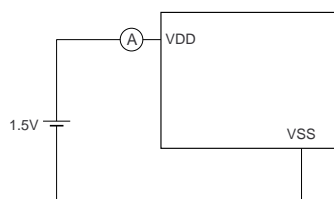

2. Measurement circuit

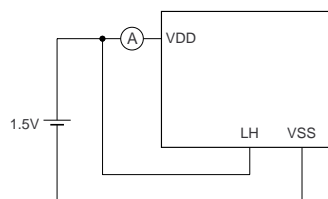

## FUNCTIONAL DESCRIPTION

### Melody Modes

The CF1155 series melody mode is determined by the bonding options and levels on the mode control inputs OSH and LH. When either OSH or LH or both go HIGH ( $V_{DD}$ ), the corresponding melody mode is selected as shown in the following table.

OSH	LH	Melody mode
HIGH	HIGH	Level hold 1
LOW	HIGH	Level hold 2
HIGH	LOW	One-shot
LOW	LOW	Non-play

### Level hold 1

When both OSH and LH go HIGH, melody play starts and continues while both are held HIGH. When both inputs go open circuit or LOW, melody play stops, even if during mid melody.

Note that both OSH and LH inputs should be switched simultaneously using a single switch. If there is timing difference between the two inputs, then LH has priority.

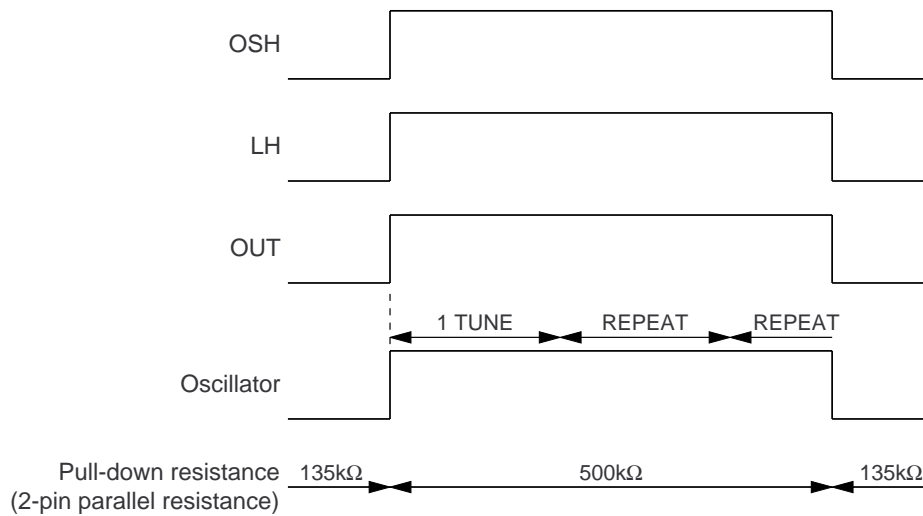

**Level hold 2**

When LH goes HIGH, a single melody play starts. Melody play continues until the single melody ends or LH goes open circuit or LOW, whichever occurs first.

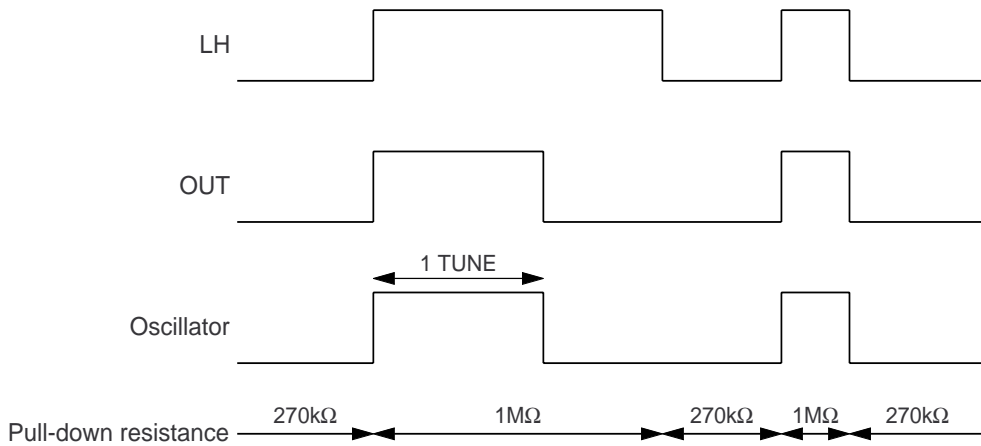

**One-shot**

When OSH goes HIGH, a single melody play starts. Melody play continues until the melody ends, even if OSH goes open circuit or LOW mid melody. However, if the OSH input goes HIGH again during melody play, the melody play restarts from the beginning.

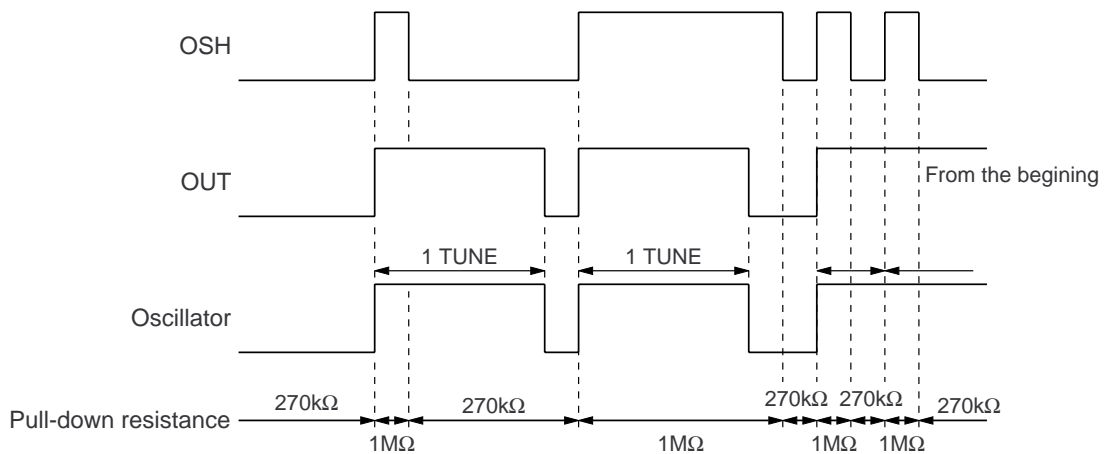

## Power-save Function

As shown in the preceding timing diagrams, the oscillator stops during non-play mode and the pull-down resistance value changes in response to both HIGH-level and LOW-level inputs (power-save pull-down resistor) to reduce power consumption and extend battery life.

### Non-play oscillator stop function

When melody play ends, regardless of the state of either LH or OSH, the internal oscillator stops and is placed in a standby state. In this state, the current consumption, including input pin pull-down resistor current ( $I_{IH}$  max), does not exceed  $3.3\mu\text{A}$ .

### Power-save pull-down resistor

The resistance of the OSH and LH input pull-down resistor changes in response to the input voltage. The pull-down resistance is  $1\text{M}\Omega$  when the input is HIGH, and the pull-down resistance is  $270\text{k}\Omega$  when the input is LOW.

Furthermore, if a light-dependent resistor (CdS) cell is employed as a switch (the pull-down resistance is maximum when the CdS resistance is minimum (light) and the pull-down resistance is minimum when the CdS resistance is maximum (dark)), the combined resistance can be increased, decreasing current consumption.

## Musical Specifications

### Maximum program steps

A maximum of 64 steps can be programmed into internal mask-programmable ROM. Each step represents either a note (sound pitch and length), a rest note, or a jump. The maximum number of jumps is 7.

### Note length (including rests)

Eight rhythm values, from sixteenth note to half note, for notes and rests can be programmed, as shown in the following table.

Type	Code							
	0	1	2	3	4	5	6	7
Note								
Rest								

Also, notes and rests longer than half notes and rests can be created using a tie to connect the notes. This requires 2 program steps in ROM.

### Tempo

The tempo for the standard quarter note can be selected from the following 16 options.

Code	0	1	2	3	4	5	6	7	8	9	A	B	C	D	E	F
$\text{♩} =$	697	348	232	174	139	116	99.4	87	77.3	69.6	63.3	58	53.5	49.7	46.4	43.5

### Pitch and scale

The CF1155 series devices support 3.5 octaves ranging from  $G_3$  to  $D_7$ , from which 15 notes can be selected to form a scale.

## TYPICAL APPLICATION

The circuits below represent the standard connections for CF1155 series devices.

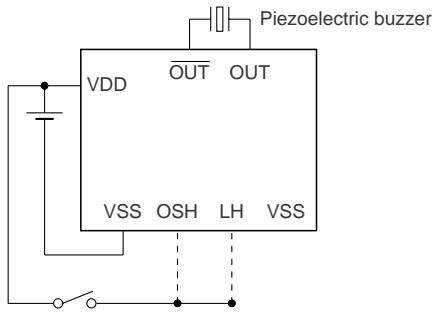

Circuit 1

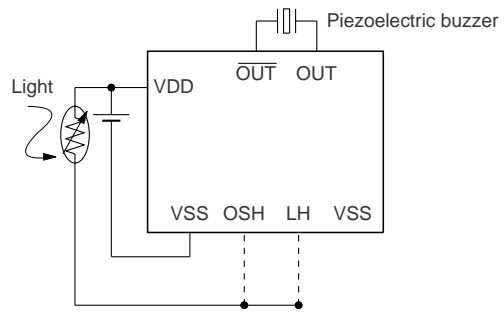

Circuit 3

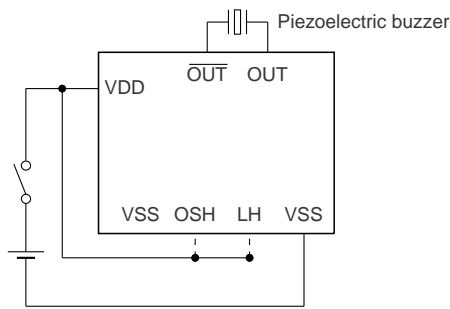

Circuit 2

Note 1: There are 2 V<sub>SS</sub> pads, and either pad can be used.

Note 2: Circuit 1 is for one-shot mode, circuit 2 for level hold 1/2 modes, and circuit 3 for CdS connection.

The bonding options for the above circuits is shown in the following table.

OSH	LH	Melody mode
Yes	Yes	Level hold 1
	Yes	Level hold 2
Yes		One-shot

NIPPON PRECISION CIRCUITS INC. reserves the right to make changes to the products described in this data sheet in order to improve the design or performance and to supply the best possible products. Nippon Precision Circuits Inc. assumes no responsibility for the use of any circuits shown in this data sheet, conveys no license under any patent or other rights, and makes no claim that the circuits are free from patent infringement. Applications for any devices shown in this data sheet are for illustration only and Nippon Precision Circuits Inc. makes no claim or warranty that such applications will be suitable for the use specified without further testing or modification. The products described in this data sheet are not intended to use for the apparatus which influence human lives due to the failure or malfunction of the products. Customers are requested to comply with applicable laws and regulations in effect now and hereinafter, including compliance with export controls on the distribution or dissemination of the products. Customers shall not export, directly or indirectly, any products without first obtaining required licenses and approvals from appropriate government agencies.



NIPPON PRECISION CIRCUITS INC.

4-3, Fukuzumi 2-chome  
Koto-ku, Tokyo 135-8430, Japan  
Telephone: 03-3642-6661  
Facsimile: 03-3642-6698

NC9922AE 2000.05