

512MB – 2x32Mx64 DDR SDRAM UNBUFFERED, w/PLL

FEATURES

- DDR200, DDR266 and DDR333
 - JEDEC design specifications
- Double-data-rate architecture
- Bi-directional data strobes (DQS)
- Differential clock inputs (CK & CK#)
- Programmable Read Latency 2,2.5 (clock)
- Programmable Burst Length (2,4,8)
- Programmable Burst type (sequential & interleave)
- Edge aligned data output, center aligned data input
- Auto and self refresh
- Serial presence detect
- Dual Rank
- Power supply: 2.5V ± 0.20V
- JEDEC standard 200 pin SO-DIMM package
 - Package height options:
 - AD4: 35.5mm (1.38")
 - BD4: 31.75mm (1.25")

DESCRIPTION

The W3EG6466S is a 2x32Mx64 Double Data Rate SDRAM memory module based on 512Mb DDR SDRAM components. The module consists of sixteen 32Mx8 components as eight 64Mx8 stacked DDR SDRAMs in 66 pin TSOP packages mounted on a 200 pin FR4 substrate.

Synchronous design allows precise cycle control with the use of system clock. Data I/O transactions are possible on both edges and Burst Lengths allow the same device to be useful for a variety of high bandwidth, high performance memory system applications.

* This product is under development, is not qualified or characterized and is subject to change without notice.

NOTE: Consult factory for availability of:

- RoHS compliant products
- Vendor source control options
- Industrial temperature option

OPERATING FREQUENCIES

| | DDR333 @CL=2.5 | DDR266 @CL=2 | DDR266 @CL=2.5 | DDR200 @CL=2 |
|-------------|----------------|--------------|----------------|--------------|
| Clock Speed | 166MHz | 133MHz | 133MHz | 100MHz |
| CL-trCD-trP | 2.5-3-3 | 2-2-2 | 2.5-3-3 | 2-2-2 |

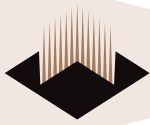

PIN CONFIGURATION

| Pin | Symbol | Pin | Symbol | Pin | Symbol | Pin | Symbol |
|-----|--------|-----|--------|-----|--------|-----|--------|
| 1 | VREF | 51 | VSS | 101 | A9 | 151 | DQ42 |
| 2 | VREF | 52 | VSS | 102 | A8 | 152 | DQ46 |
| 3 | VSS | 53 | DQ19 | 103 | VSS | 153 | DQ43 |
| 4 | VSS | 54 | DQ23 | 104 | VSS | 154 | DQ47 |
| 5 | DQ0 | 55 | DQ24 | 105 | A7 | 155 | VCC |
| 6 | DQ4 | 56 | DQ28 | 106 | A6 | 156 | VCC |
| 7 | DQ1 | 57 | VCC | 107 | A5 | 157 | VCC |
| 8 | DQ5 | 58 | VCC | 108 | A4 | 158 | NC |
| 9 | VCC | 59 | DQ25 | 109 | A3 | 159 | VSS |
| 10 | VCC | 60 | DQ29 | 110 | A2 | 160 | NC |
| 11 | DQS0 | 61 | DQS3 | 111 | A1 | 161 | VSS |
| 12 | DQM0 | 62 | DQM3 | 112 | A0 | 162 | VSS |
| 13 | DQ2 | 63 | VSS | 113 | VCC | 163 | DQ48 |
| 14 | DQ6 | 64 | VSS | 114 | VCC | 164 | DQ52 |
| 15 | VSS | 65 | DQ26 | 115 | A10/AP | 165 | DQ49 |
| 16 | VSS | 66 | DQ30 | 116 | BA1 | 166 | DQ53 |
| 17 | DQ3 | 67 | DQ27 | 117 | BA0 | 167 | VCC |
| 18 | DQ7 | 68 | DQ31 | 118 | RAS# | 168 | VCC |
| 19 | DQ8 | 69 | VCC | 119 | WE# | 169 | DQS6 |
| 20 | DQ12 | 70 | VCC | 120 | CAS# | 170 | DQM6 |
| 21 | VCC | 71 | NC | 121 | CS0# | 171 | DQ50 |
| 22 | VCC | 72 | NC | 122 | CS1# | 172 | DQ54 |
| 23 | DQ9 | 73 | NC | 123 | NC | 173 | VSS |
| 24 | DQ13 | 74 | NC | 124 | NC | 174 | VSS |
| 25 | DQS1 | 75 | VSS | 125 | VSS | 175 | DQ51 |
| 26 | DQM1 | 76 | VSS | 126 | VSS | 176 | DQ55 |
| 27 | VSS | 77 | DQS8 | 127 | DQ32 | 177 | DQ56 |
| 28 | VSS | 78 | DQM8 | 128 | DQ36 | 178 | DQ60 |
| 29 | DQ10 | 79 | NC | 129 | DQ33 | 179 | VCC |
| 30 | DQ14 | 80 | NC | 130 | DQ37 | 180 | VCC |
| 31 | DQ11 | 81 | VCC | 131 | VCC | 181 | DQ57 |
| 32 | DQ15 | 82 | VCC | 132 | VCC | 182 | DQ61 |
| 33 | VCC | 83 | NC | 133 | DQS4 | 183 | DQS7 |
| 34 | VCC | 84 | NC | 134 | DQM4 | 184 | DQM7 |
| 35 | CK0 | 85 | NC | 135 | DQ34 | 185 | VSS |
| 36 | VCC | 86 | NC | 136 | DQ38 | 186 | VSS |
| 37 | CK0# | 87 | VSS | 137 | VSS | 187 | DQ58 |
| 38 | VSS | 88 | VSS | 138 | VSS | 188 | DQ62 |
| 39 | VSS | 89 | NC | 139 | DQ35 | 189 | DQ59 |
| 40 | VSS | 90 | VSS | 140 | DQ39 | 190 | DQ63 |
| 41 | DQ16 | 91 | NC | 141 | DQ40 | 191 | VCC |
| 42 | DQ20 | 92 | VCC | 142 | DQ44 | 192 | VCC |
| 43 | DQ17 | 93 | VCC | 143 | VCC | 193 | SDA |
| 44 | DQ21 | 94 | VCC | 144 | VCC | 194 | SA0 |
| 45 | VCC | 95 | CKE1 | 145 | DQ41 | 195 | SCL |
| 46 | VCC | 96 | CKE0 | 146 | DQ45 | 196 | SA1 |
| 47 | DQS2 | 97 | NC | 147 | DQS5 | 197 | VCCSPD |
| 48 | DQM2 | 98 | NC | 148 | DQM5 | 198 | SA2 |
| 49 | DQ18 | 99 | A12 | 149 | VSS | 199 | VCCID |
| 50 | DQ22 | 100 | A11 | 150 | VSS | 200 | NC |

PIN NAMES

| | |
|-----------|----------------------------|
| A0 – A12 | Access input (Multiplexed) |
| BA0-BA1 | Bank Select Access |
| DQ0-DQ63 | Data Input/Output |
| DQS0-DQS7 | Data Strobe Input/Output |
| CK0 | Clock Input |
| CK0# | Clock input |
| CKE0-CKE1 | Clock Enable input |
| CS0#-CS1# | Chip select Input |
| RAS# | Row Access Strobe |
| CAS# | Column Access Strobe |
| WE# | Write Enable |
| DQM0-DQM7 | Data-In Mask |
| VCC | Power Supply |
| VSS | Ground |
| VREF | Power Supply for Reference |
| VCCSPD | Serial EEPROM Power Supply |
| SDA | Serial data I/O |
| SCL | Serial clock |
| SA0-SA2 | Access in EEPROM |
| VCCID | VCC Identification Flag |
| NC | No Connect |

* Not Used



FUNCTIONAL BLOCK DIAGRAM

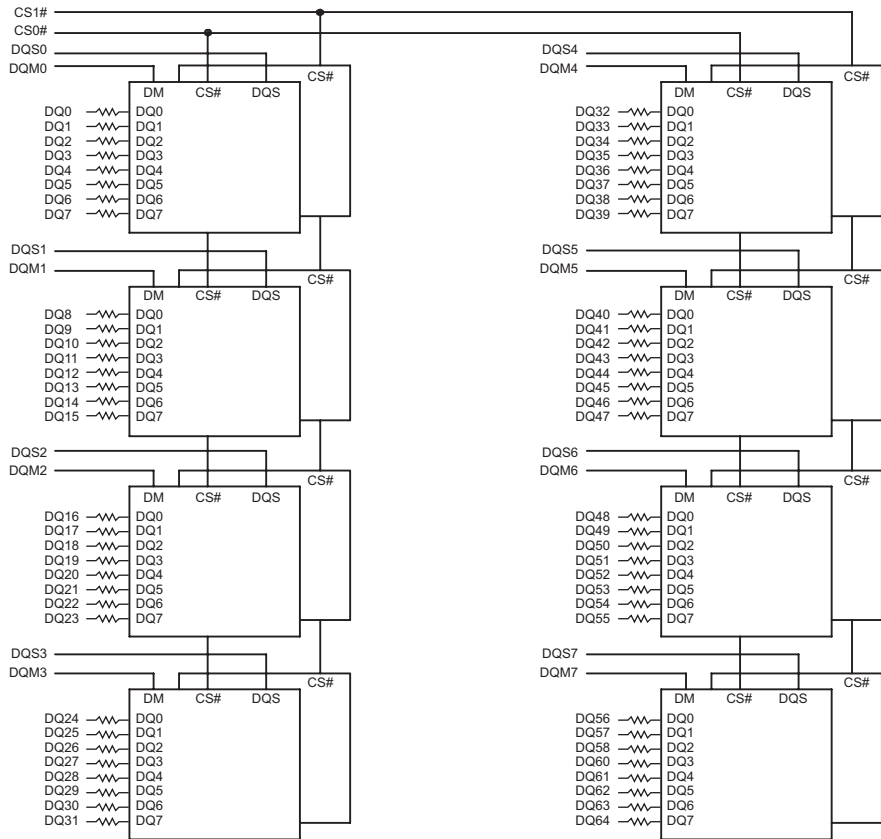

- RAS#** → RAS: DDR SDRAMs
- CAS#** → CAS: DDR SDRAMs
- BA0-BA1** → BA0-BA1: DDR SDRAMs
- WE#** → WE: DDR SDRAMs
- A0-A12** → A0-A12: DDR SDRAMs
- CKE0** → CKE0: DDR SDRAMs
- CKE1** → CKE1: DDR SDRAMs

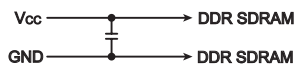
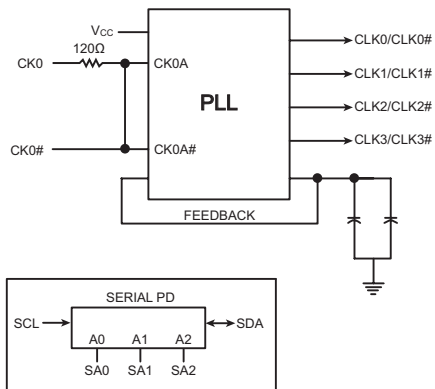

NOTE: All datalines are terminated through a 22 ohm series resistor.

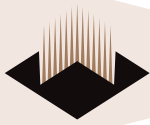

ABSOLUTE MAXIMUM RATINGS

| Parameter | Symbol | Value | Units |
|---|------------------------------------|-------------|-------|
| Voltage on any pin relative to V _{SS} | V _{IN} , V _{OUT} | -0.5 to 3.6 | V |
| Voltage on V _{CC} supply relative to V _{SS} | V _{CC} , V _{CCQ} | -1.0 to 3.6 | V |
| Storage Temperature | T _{STG} | -55 to +150 | °C |
| Power Dissipation | P _D | 16 | W |
| Short Circuit Current | I _{OS} | 50 | mA |

Note:

- Permanent device damage may occur if "ABSOLUTE MAXIMUM RATINGS" are exceeded.
- Functional operation should be restricted to recommended operating condition.
- Exposure to higher than recommended voltage for extended periods of time could affect device reliability.

DC CHARACTERISTICS

0°C ≤ T_A ≤ 70°C, V_{CC} = 2.5V ± 0.2V

| Parameter | Symbol | Min | Max | Unit |
|---------------------|------------------|----------------------------|----------------------------|------|
| Supply Voltage | V _{CC} | 2.3 | 2.7 | V |
| Supply Voltage | V _{CCQ} | 2.3 | 2.7 | V |
| Reference Voltage | V _{REF} | V _{CCQ} /2 - 50mV | V _{CCQ} /2 + 50mV | V |
| Termination Voltage | V _{TT} | V _{REF} - 0.04 | V _{REF} + 0.04 | V |
| Input High Voltage | V _{IH} | V _{REF} + 0.15 | V _{CCQ} + 0.3 | V |
| Input Low Voltage | V _{IL} | -0.3 | V _{REF} - 0.15 | V |
| Output High Voltage | V _{OH} | V _{TT} + 0.76 | — | V |
| Output Low Voltage | V _{OL} | — | V _{TT} - 0.76 | V |

CAPACITANCE

T_A = 25°C, f = 1MHz, V_{CC} = 3.3V, V_{REF} = 1.4V ± 200mV

| Parameter | Symbol | Max | Unit |
|---|------------------|-----|------|
| Input Capacitance (A0-A12) | C _{IN1} | 50 | pF |
| Input Capacitance (RAS#, CAS#, WE#) | C _{IN2} | 50 | pF |
| Input Capacitance (CKE0, CKE1) | C _{IN3} | 26 | pF |
| Input Capacitance (CK0, CK0#) | C _{IN4} | 5.5 | pF |
| Input Capacitance (CS0#, CS1#) | C _{IN5} | 26 | pF |
| Input Capacitance (DQM0-DQM8) | C _{IN6} | 13 | pF |
| Input Capacitance (BA0-BA1) | C _{IN7} | 50 | pF |
| Data input/output capacitance (DQ0-DQ63)(DQS) | C _{OUT} | 13 | pF |

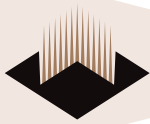

I_{DD} SPECIFICATIONS AND TEST CONDITIONS

0°C ≤ T_A ≤ 70°C, V_{CCQ} = 2.5V ±0.2V, V_{CC} = 2.5V ±0.2V

| Parameter | Symbol | Conditions | DDR333@CL=2.5 Max | DDR266@CL=2, 2.5 Max | DDR200@CL=2 Max | Units |
|--------------------------------------|-------------------|---|----------------------|-------------------------|--------------------|-------|
| Operating Current | I _{DD0} | One device bank; Active - Precharge; t _{RC} =t _{RC} (MIN); t _{CK} =t _{CK} (MIN); DQ,DM and DQS inputs changing once per clock cycle; Address and control inputs changing once every two cycles. | 1600 | 1440 | 1360 | mA |
| Operating Current | I _{DD1} | One device bank; Active-Read-Precharge; Burst = 2; t _{RC} =t _{RC} (MIN); t _{CK} =t _{CK} (MIN); I _{out} = 0mA; Address and control inputs changing once per clock cycle. | 1800 | 1640 | 1560 | mA |
| Precharge Power-Down Standby Current | I _{DD2P} | All device banks idle; Power- down mode; t _{CK} =t _{CK} (MIN); CKE=(low) | 48 | 48 | 48 | mA |
| Idle Standby Current | I _{DD2F} | CS# = High; All device banks idle; t _{CK} =t _{CK} (MIN); CKE = high; Address and other control inputs changing once per clock cycle. V _{in} = V _{ref} for DQ, DQS and DM. | 400 | 320 | 320 | mA |
| Active Power-Down Standby Current | I _{DD3P} | One device bank active; Power-down mode; t _{CK} (MIN); CKE=(low) | 560 | 480 | 480 | mA |
| Active Standby Current | I _{DD3N} | CS# = High; CKE = High; One device bank; Active-Precharge; t _{RC} =t _{RAS} (MAX); t _{CK} =t _{CK} (MIN); DQ, DM and DQS inputs changing twice per clock cycle; Address and other control inputs changing once per clock cycle. | 880 | 720 | 720 | mA |
| Operating Current | I _{DD4R} | Burst = 2; Reads; Continous burst; One device bank active;Address and control inputs changing once per clock cycle; t _{CK} =t _{CK} (MIN); I _{out} = 0mA. | 2160 | 1840 | 1840 | mA |
| Operating Current | I _{DD4W} | Burst = 2; Writes; Continous burst; One device bank active; Address and control inputs changing once per clock cycle; t _{CK} =t _{CK} (MIN); DQ,DM and DQS inputs changing twice per clock cycle. | 2160 | 1800 | 1800 | mA |
| Auto Refresh Current | I _{DD5} | t _{RC} =t _{RC} (MIN) | 2240 | 2000 | 2000 | mA |
| Self Refresh Current | I _{DD6} | CKE £ 0.2V | 48 | 48 | 48 | mA |
| Operating Current | I _{DD7A} | Four bank interleaving Reads (BL=4) with auto precharge with t _{RC} =t _{RC} (MIN); t _{CK} =t _{CK} (MIN); Address and control inputs change only during Active Read or Write commands. | 3120 | 2960 | 2720 | mA |

* For DDR333 consult factory

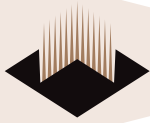

DETAILED TEST CONDITIONS FOR DDR SDRAM I_{DD1} & I_{DD7A}

I_{DD1} : OPERATING CURRENT : ONE BANK

1. Typical Case : V_{CC}=2.5V, T=25°C
2. Worst Case : V_{CC}=2.7V, T=10°C
3. Only one bank is accessed with t_{RC} (min), Burst Mode, Address and Control inputs on NOP edge are changing once per clock cycle. I_{OUT} = 0mA
4. Timing Patterns :
 - DDR200 (100 MHz, CL=2) : t_{CK}=10ns, CL2, BL=4, t_{RCD}=2*t_{CK}, t_{TRAS}=5*t_{CK}
Read : A0 N R0 N N P0 N A0 N - repeat the same timing with random address changing; 50% of data changing at every burst
 - DDR266 (133MHz, CL=2.5) : t_{CK}=7.5ns, CL=2.5, BL=4, t_{RCD}=3*t_{CK}, t_{RC}=9*t_{CK}, t_{TRAS}=5*t_{CK}
Read : A0 N N R0 N P0 N N A0 N - repeat the same timing with random address changing; 50% of data changing at every burst
 - DDR266 (133MHz, CL=2) : t_{CK}=7.5ns, CL=2, BL=4, t_{RCD}=3*t_{CK}, t_{RC}=9*t_{CK}, t_{TRAS}=5*t_{CK}
Read : A0 N N R0 N P0 N N A0 N - repeat the same timing with random address changing; 50% of data changing at every burst
 - DDR333 (166MHz, CL=2.5) : t_{CK}=6ns, BL=4, t_{RCD}=10*t_{CK}, t_{TRAS}=7*t_{CK}
Read : A0 N N R0 N P0 N N A0 N - repeat the same timing with random address changing; 50% of data changing at every burst

I_{DD7A} : OPERATING CURRENT : FOUR BANKS

1. Typical Case : V_{CC}=2.5V, T=25°C
2. Worst Case : V_{CC}=2.7V, T=10°C
3. Four banks are being interleaved with t_{RC} (min), Burst Mode, Address and Control inputs on NOP edge are not changing. I_{OUT}=0mA
4. Timing Patterns :
 - DDR200 (100 MHz, CL=2) : t_{CK}=10ns, CL2, BL=4, t_{RRD}=2*t_{CK}, t_{RCD}=3*t_{CK}, Read with Autoprecharge
Read : A0 N A1 R0 A2 R1 A3 R2 A0 R3 A1 R0 - repeat the same timing with random address changing; 100% of data changing at every burst
 - DDR266 (133MHz, CL=2.5) : t_{CK}=7.5ns, CL=2.5, BL=4, t_{RRD}=3*t_{CK}, t_{RCD}=3*t_{CK}
Read with Autoprecharge
Read : A0 N A1 R0 A2 R1 A3 R2 N R3 A0 N A1 R0 - repeat the same timing with random address changing; 100% of data changing at every burst
 - DDR266 (133MHz, CL=2) : t_{CK}=7.5ns, CL2=2, BL=4, t_{RRD}=2*t_{CK}, t_{RCD}=2*t_{CK}
Read : A0 N A1 R0 A2 R1 A3 R2 N R3 A0 N A1 R0 - repeat the same timing with random address changing; 100% of data changing at every burst
 - DDR333 (166MHz, CL=2.5) : t_{CK}=6ns, BL=4, t_{RRD}=3*t_{CK}, t_{RCD}=3*t_{CK}, Read with Autoprecharge
Read : A0 N A1 R0 A2 R1 A3 R2 N R3 A0 N A1 R0 - repeat the same timing with random address changing; 100% of data changing at every burst

Legend : A = Activate, R = Read, W = Write, P = Precharge, N = NOP

A (0-3) = Activate Bank 0-3

R (0-3) = Read Bank 0-3

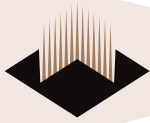

DDR SDRAM COMPONENT ELECTRICAL CHARACTERISTICS AND RECOMMENDED AC OPERATING CONDITIONS

| AC CHARACTERISTICS | | 335 | | 262 | | 265/202 | | UNITS | NOTES | |
|--|--------------------|-----------------------------------|-------|-----------------------------------|-------|-----------------------------------|--------|-----------------|--------|--------|
| PARAMETER | SYMBOL | MIN | MAX | MIN | MAX | MIN | MAX | | | |
| Access window of DQs from CK/CK# | t _{AC} | -0.70 | +0.70 | -0.75 | +0.75 | -0.75 | +0.75 | ns | | |
| CK high-level width | t _{CH} | 0.45 | 0.55 | 0.45 | 0.55 | 0.45 | 0.55 | t _{CK} | 26 | |
| CK low-level width | t _{CL} | 0.45 | 0.55 | 0.45 | 0.55 | 0.45 | 0.55 | t _{CK} | 26 | |
| Clock cycle time | CL = 2.5 | t _{CK(2.5)} | 6 | 13 | 7.5 | 13 | 7.5 | 13 | ns | 39, 44 |
| | CL = 2 | t _{CK(2)} | 7.5 | 13 | 7.5 | 13 | 7.5/10 | 13 | ns | 39, 44 |
| DQ and DM input hold time relative to DQS | t _{DH} | 0.45 | | 0.5 | | 0.5 | | ns | 23, 27 | |
| DQ and DM input setup time relative to DQS | t _{DS} | 0.45 | | 0.5 | | 0.5 | | ns | 23, 27 | |
| DQ and DM input pulse width (for each input) | t _{DIPW} | 1.75 | | 1.75 | | 1.75 | | ns | 27 | |
| Access window of DQS from CK/CK# | t _{DQACK} | -0.60 | +0.60 | -0.75 | +0.75 | -0.75 | +0.75 | ns | | |
| DQS input high pulse width | t _{DQSH} | 0.35 | | 0.35 | | 0.35 | | t _{CK} | | |
| DQS input low pulse width | t _{DQSL} | 0.35 | | 0.35 | | 0.35 | | t _{CK} | | |
| DQS-DQ skew, DQS to last DQ valid, per group, per access | t _{DQSQ} | | 0.4 | | 0.5 | | 0.5 | ns | 22, 23 | |
| Write command to first DQS latching transition | t _{DQSS} | 0.75 | 1.25 | 0.75 | 1.25 | 0.75 | 1.25 | t _{CK} | | |
| DQS falling edge to CK rising - setup time | t _{DSS} | 0.20 | | 0.20 | | 0.20 | | t _{CK} | | |
| DQS falling edge from CK rising - hold time | t _{DSH} | 0.20 | | 0.20 | | 0.20 | | t _{CK} | | |
| Half clock period | t _{HP} | t _{CH} , t _{CL} | | t _{CH} , t _{CL} | | t _{CH} , t _{CL} | | ns | 8 | |
| Data-out high-impedance window from CK/CK# | t _{HZ} | | +0.70 | | +0.75 | | +0.75 | ns | 16, 36 | |
| Data-out low-impedance window from CK/CK# | t _{LZ} | -0.70 | | -0.75 | | -0.75 | | ns | 16, 36 | |
| Address and control input hold time (fast slew rate) | t _{IHF} | 0.75 | | 0.90 | | 0.90 | | ns | 12 | |
| Address and control input setup time (fast slew rate) | t _{ISF} | 0.75 | | 0.90 | | .900 | | ns | 12 | |
| Address and control input hold time (slow slew rate) | t _{IHS} | 0.8 | | 1 | | 1 | | ns | 12 | |
| Address and control input setup time (slow slew rate) | t _{ISS} | 0.8 | | 1 | | 1 | | ns | 12 | |
| Address and Control input pulse width (for each input) | t _{IPW} | 2.2 | | 2.2 | | 2.2 | | ns | | |
| LOAD MODE REGISTER command cycle time | t _{MRD} | 12 | | 15 | | 15 | | ns | | |

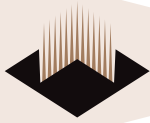

DDR SDRAM COMPONENT ELECTRICAL CHARACTERISTICS AND RECOMMENDED AC OPERATING CONDITIONS (Continued)

| AC CHARACTERISTICS | | 335 | | 262 | | 265/202 | | UNITS | NOTES |
|--|--------------------|-------------------------------------|--------|-------------------------------------|---------|-------------------------------------|---------|-----------------|--------|
| PARAMETER | SYMBOL | MIN | MAX | MIN | MAX | MIN | MAX | | |
| DQ-DQS hold, DQS to first DQ to go non-valid, per access | t _{QH} | t _{HP} - t _{QHS} | | t _{HP} - t _{QHS} | | t _{HP} - t _{QHS} | | ns | 22, 23 |
| Data hold skew factor | t _{QHS} | | 0.75 | | 0.75 | | 0.75 | ns | |
| ACTIVE to PRECHARGE command | t _{RAS} | 42 | 70,000 | 40 | 120,000 | 40 | 120,000 | ns | 31, 47 |
| ACTIVE to READ with Auto precharge command | t _{RAP} | 15 | | 15 | | 20 | | ns | |
| ACTIVE to ACTIVE/AUTO REFRESH command period | t _{RC} | 60 | | 60 | | 65 | | ns | |
| AUTO REFRESH command period | t _{RFC} | 72 | | 75 | | 75 | | ns | 42 |
| ACTIVE to READ or WRITE delay | t _{RCD} | 15 | | 15 | | 20 | | ns | |
| PRECHARGE command period | t _{RP} | 15 | | 15 | | 20 | | ns | |
| DQS read preamble | t _{RPRE} | 0.9 | 1.1 | 0.9 | 1.1 | 0.9 | 1.1 | t _{CK} | 37 |
| DQS read postamble | t _{RPST} | 0.4 | 0.6 | 0.4 | 0.6 | 0.4 | 0.6 | t _{CK} | 37 |
| ACTIVE bank a to ACTIVE bank b command | t _{RRD} | 12 | | 15 | | 15 | | ns | |
| DQS write preamble | t _{WPRE} | 0.25 | | 0.25 | | 0.25 | | t _{CK} | |
| DQS write preamble setup time | t _{WPRES} | 0 | | 0 | | 0 | | ns | 18, 19 |
| DQS write postamble | t _{WPST} | 0.4 | 0.6 | 0.4 | 0.6 | 0.4 | 0.6 | t _{CK} | 17 |
| Write recovery time | t _{WR} | 15 | | 15 | | 15 | | ns | |
| Internal WRITE to READ command delay | t _{WTR} | 1 | | 1 | | 1 | | t _{CK} | |
| Data valid output window | NA | t _{QH} - t _{BOSQ} | | t _{QH} - t _{BOSQ} | | t _{QH} - t _{BOSQ} | | ns | 22 |
| REFRESH to REFRESH command interval | t _{REFC} | | 70.3 | | 70.3 | | 70.3 | μs | 21 |
| Average periodic refresh interval | t _{REFI} | | 7.8 | | 7.8 | | 7.8 | μs | 21 |
| Terminating voltage delay to VDD | t _{VTD} | 0 | | 0 | | 0 | | ns | |
| Exit SELF REFRESH to non-READ command | t _{XSNR} | 75 | | 75 | | 75 | | ns | |
| Exit SELF REFRESH to READ command | t _{XSRD} | 200 | | 200 | | 200 | | t _{CK} | |



Notes

1. All voltages referenced to V_{SS} .
2. Tests for AC timing, I_{DD} , and electrical AC and DC characteristics may be conducted at nominal reference/supply voltage levels, but the related specifications and device operation are guaranteed for the full voltage range specified.
3. Outputs measured with equivalent load:

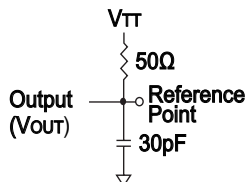

4. AC timing and I_{DD} tests may use a V_{IL} -to- V_{IH} swing of up to 1.5V in the test environment, but input timing is still referenced to V_{REF} (or to the crossing point for CK/CK#), and parameter specifications are guaranteed for the specified AC input levels under normal use conditions. The mini-mum slew rate for the input signals used to test the device is 1V/ns in the range between $V_{IL}(AC)$ and $V_{IH}(AC)$.
5. The AC and DC input level specifications are as defined in the SSTL_2 Standard (i.e., the receiver will effectively switch as a result of the signal crossing the AC input level, and will remain in that state as long as the signal does not ring back above [below] the DC input LOW [HIGH] level).
6. V_{REF} is expected to equal $V_{CCQ/2}$ of the transmitting device and to track variations in the DC level of the same. Peak-to-peak noise (non-common mode) on V_{REF} may not exceed ± 2 percent of the DC value. Thus, from $V_{CCQ/2}$, V_{REF} is allowed $\pm 25mV$ for DC error and an additional $\pm 25mV$ for AC noise. This measurement is to be taken at the nearest V_{REF} bypass capacitor.
7. V_{TT} is not applied directly to the device. V_{TT} is a system supply for signal termination resistors, is expected to be set equal to V_{REF} and must track variations in the DC level of V_{REF} .
8. I_{DD} is dependent on output loading and cycle rates. Specified values are obtained with mini-mum cycle time at CL = 2 for 262, 263, and 202, CL = 2.5 for 335 and 265 with the outputs open.
9. Enables on-chip refresh and address counters.
10. I_{DD} specifications are tested after the device is properly initialized, and is averaged at the defined cycle rate.
11. This parameter is sampled. $V_{CC} = +2.5V \pm 0.2V$, $V_{CCQ} = +2.5V \pm 0.2V$, $V_{REF} = V_{SS}$, $f = 100$ MHz, $T = 25^\circ C$, $V_{OUT}(DC) = V_{CCQ/2}$, V_{OUT} (peak to peak) $T_A = 0.2V$. DM input is grouped with I/O pins, reflecting the fact that they are matched in loading.
12. For slew rates less than 1 V/ns and greater than or equal to 0.5 V/ns. If slew rate is less than 0.5 V/ns, timing must be derated: t_{IS} has an additional 50ps per each 100mV/ns reduction in slew rate from 500mV/ns, while t_{IH} is unaffected. If slew rate exceeds 4.5 V/ns, functionality is uncertain. For 335, slew rates must be ≥ 0.5 V/ns.
13. The CK/CK# input reference level (for timing referenced to CK/CK#) is the point at which CK and CK# cross; the input reference level for signals other than CK/CK# is V_{REF} .
14. Inputs are not recognized as valid until V_{REF} stabilizes. Exception: during the period before V_{REF} stabilizes, $CKE < 0.3 \times V_{CCQ}$ is recognized as LOW.
15. The output timing reference level, as measured at the timing reference point indicated in Note 3, is V_{TT} .
16. t_{HZ} and t_{LZ} transitions occur in the same access time windows as valid data transitions. These parameters are not referenced to a specific voltage level, but specify when the device output is no longer driving (HZ) or begins driving (LZ).

17. The intent of the Don't Care state after completion of the postamble is the DQS-driven signal should either be high, low, or high-Z and that any signal transition within the input switching region must follow valid input requirements. That is, if DQS transitions high (above V_{IH} DC (MIN)) then it must not transition low (below V_{IH} DC) prior to t_{DQSH} (MIN).
18. This is not a device limit. The device will operate with a negative value, but system performance could be degraded due to bus turnaround.
19. It is recommended that DQS be valid (HIGH or LOW) on or before the WRITE command. The case shown (DQS going from High-Z to logic LOW) applies when no WRITES were previously in progress on the bus. If a previous WRITE was in progress, DQS could be HIGH during this time, depending on t_{DQSH} .
20. MIN (t_{RC} or t_{RFC}) for I_{DD} measurements is the smallest multiple of t_{CK} that meets the minimum absolute Value for the respective parameter. t_{RAS} (MAX) for I_{DD} measurements is the largest multiple of t_{CK} that meets the maximum absolute value for t_{RAS} .
21. The refresh period 64ms. This equates to an average refresh rate of 7.8125 μs . However, an AUTO REFRESH command must be asserted at least once every 70.3 μs ; burst refreshing or posting by the DRAM controller greater than eight refresh cycles is not allowed.
22. The valid data window is derived by achieving other specifications: t_{HP} ($t_{CK/2}$), t_{DQSQ} , and t_{QH} ($t_{QH} = t_{HP} - t_{QHS}$). The data valid window derates directly proportional with the clock duty cycle and a practical data valid window can be derived. The clock is allowed a maximum duty cycle variation of 45/55, beyond which functionality is uncertain. Figure 8, Derating Data Valid Window, shows derating curves for duty cycles ranging between 50/50 and 45/55.
23. Each byte lane has a corresponding DQS.
24. This limit is actually a nominal value and does not result in a fail value. CKE is HIGH during REFRESH command period (t_{RFC} [MIN]) else CKE is LOW (i.e., during standby).
25. To maintain a valid level, the transitioning edge of the input must:
 - a. Sustain a constant slew rate from the current AC level through to the target AC level, $V_{IL}(AC)$ or $V_{IH}(AC)$.
 - b. Reach at least the target AC level. After the AC target level is reached, continue to maintain at least the target DC level, $V_{IL}(DC)$ or $V_{IH}(DC)$.
26. JEDEC specifies CK and CK# input slew rate must be $\geq 1V/ns$ (2V/ns differentially).
27. DQ and DM input slew rates must not deviate from DQS by more than 10 percent. If the DQ/ DM/DQS slew rate is less than 0.5V/ns, timing must be derated: 50ps must be added to t_{DS} and t_{DH} for each 100mV/ns reduction in slew rate. If slew rate exceeds 4V/ns, functionality is uncertain. For 335, slew rates must be ≥ 0.5 V/ns.
28. V_{CC} must not vary more than 4 percent if CKE is not active while any bank is active.
29. The clock is allowed up to $\pm 150ps$ of jitter. Each timing parameter is allowed to vary by the same amount.
30. t_{HP} min is the lesser of t_{CL} minimum and t_{CH} minimum actually applied to the device CK and CK# inputs, collectively during bank active.
31. READs and WRITEs with auto precharge are not allowed to be issued until $t_{RAS}(MIN)$ can be satisfied prior to the internal precharge command being issued.
32. Any positive glitch must be less than 1/3 of the clock and not more than +400mV or 2.9V, whichever is less. Any negative glitch must be less than 1/3 of the clock cycle and not exceed either -300mV or 2.2V, whichever is more positive.

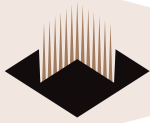

33. The voltage levels used are derived from a minimum V_{CC} level and the referenced test load. In practice, the voltage levels obtained from a properly terminated bus will provide significantly different voltage values.
34. V_{IH} overshoot: $V_{IH} (MAX) = V_{CCQ} + 1.5V$ for a pulse width $\leq 3ns$ and the pulse width can not be greater than 1/3 of the cycle rate. V_{IL} undershoot: $V_{IL} (MIN) = -1.5V$ for a pulse width $\leq 3ns$ and the pulse width can not be greater than 1/3 of the cycle rate.
35. V_{CC} and V_{CCQ} must track each other.
36. $t_{HZ} (MAX)$ will prevail over $t_{DQCK} (MAX) + t_{RPST} (MAX)$ condition. $t_{LZ} (MIN)$ will prevail over $t_{DQCK} (MIN) + t_{RPRE} (MAX)$ condition.
37. t_{RPST} end point and t_{RPRE} begin point are not referenced to a specific voltage level but specify when the device output is no longer driving (t_{RPST}), or begins driving (t_{RPRE}).
38. During Initialization, V_{CCQ} , V_{TT} , and V_{REF} must be equal to or less than $V_{CC} + 0.3V$. Alternatively, V_{TT} may be 1.35V maximum during power up, even if V_{CC}/V_{CCQ} are 0.0V, provided a minimum of 42 Ω of series resistance is used between the V_{TT} supply and the input pin.
39. The current part operates below the slowest JEDEC operating frequency of 83 MHz. As such, future die may not reflect this option.
40. Random addressing changing and 50 percent of data changing at every transfer.
41. Random addressing changing and 100 percent of data changing at every transfer.
42. CKE must be active (high) during the entire time a refresh command is executed. That is, from the time the AUTO REFRESH command is registered, CKE must be active at each rising clock edge, until t_{REF} later.
43. I_{DD2N} specifies the DQ , DQS , and DM to be driven to a valid high or low logic level. I_{DD2Q} is similar to I_{DD2F} except I_{DD2Q} specifies the address and control inputs to remain stable. Although I_{DD2F} , I_{DD2N} , and I_{DD2Q} are similar, I_{DD2F} is "worst case."
44. Whenever the operating frequency is altered, not including jitter, the DLL is required to be reset. This is followed by 200 clock cycles.
45. Leakage number reflects the worst case leakage possible through the module pin, not what each memory device contributes.
46. When an input signal is HIGH or LOW, it is defined as a steady state logic HIGH or LOW.
47. The 335 speed grade will operate with $t_{RAS} (MIN) = 40ns$ and $t_{RAS} (MAX) = 120,000ns$ at any slower frequency.



ORDERING INFORMATION FOR BD4

| Part Number | Speed | Height* |
|-----------------|------------------------|--------------|
| W3EG6466S335BD4 | 166MHz/333Mbps, CL=2.5 | 31.75 (1.25) |
| W3EG6466S262BD4 | 133MHz/266Mbps, CL=2 | 31.75 (1.25) |
| W3EG6466S265BD4 | 133MHz/266Mbps, CL=2.5 | 31.75 (1.25) |
| W3EG6466S202BD4 | 100MHz/200Mbps, CL=2 | 31.75 (1.25) |

- NOTES:
- Consult Factory for availability of RoHS compliant products. (G = RoHS Compliant)
 - Vendor specific part numbers are used to provide memory components source control. The place holder for this is shown as lower case "x" in the part numbers above and is to be replaced with the respective vendors code. Consult factory for qualified sourcing options. (M = Micron, S = Samsung & consult factory for others)
 - Consult factory for availability of industrial temperature (-40°C to 85°C) option

PACKAGE DIMENSIONS FOR BD4

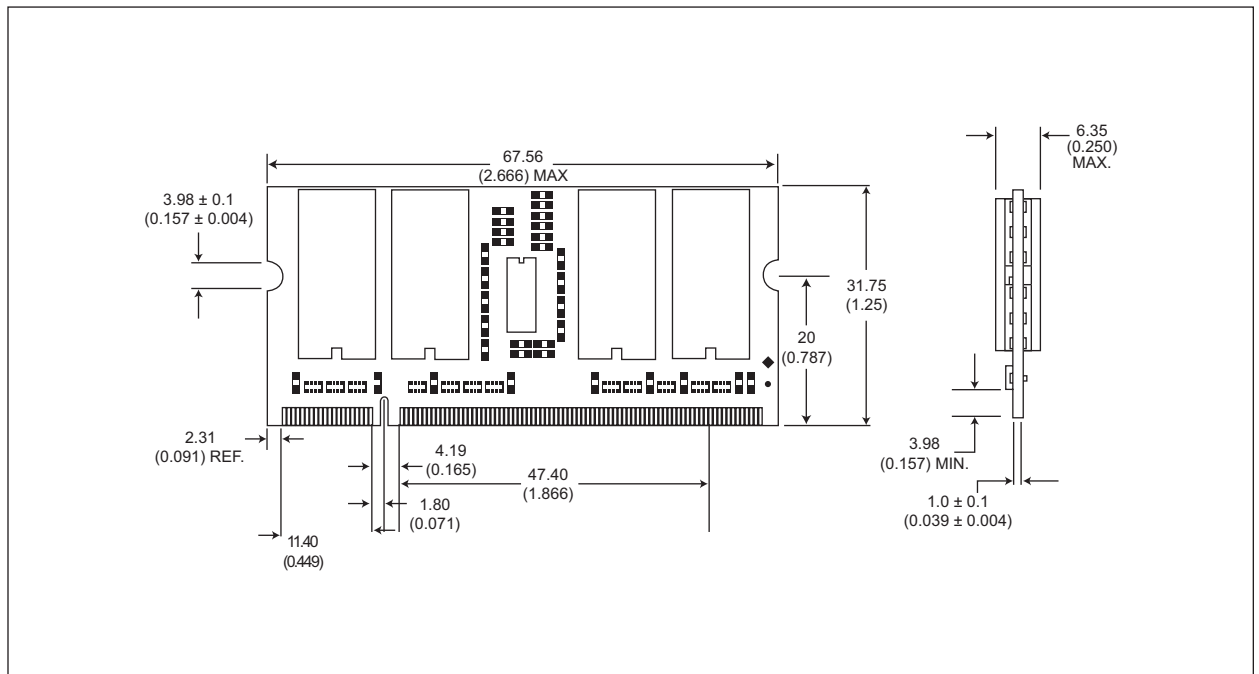

* ALL DIMENSIONS ARE IN MILLIMETERS AND (INCHES)



Document Title

512MB – 64Mx64 DDR SDRAM UNBUFFERED, w/PLL

Revision History

| Rev # | History | Release Date | Status |
|-------|--|--------------|-------------|
| Rev A | Created | 7-21-02 | Advanced |
| Rev 0 | 0.1 Upated I _{DD} specs. 0.2 Added AD4 and BD4 package options 0.3 Added document title page 0.4 Removed "ED" from part number 0.5 Moved from advanced to preliminary | 8-04 | Preliminary |
| Rev 1 | 1.0 Upated I _{DD} and CAP specs. 1.1 Added AC specs | 11-04 | Preliminary |
| Rev 2 | 2.1 Added lead-free and RoHS notes 2.2 Added source control notes 2.3 Added industrial temperature options | 1-05 | Preliminary |