**THREE PHASE POWER/ENERGY METERING MODULE
PULSE OUTPUT**

FEATURES

- Performs one, two or three phase power and energy measurement
- Meets the accuracy requirements for Class 1 AC Watt hour meters
- Operates over a wide Temperature Range
- Uses current transformers for current sensing
- Three pulse rate outputs available
- Protected against ESD

DESCRIPTION

The SAMES three phase power/energy metering module, the PM9105AP provides three pulse rate output options, the frequency of which are proportional to the active power consumption.

Energy consumption can be determined by the power measurement being integrated over time.

The method of calculation takes the power factor into account.

The output of this innovative universal three phase power/energy metering circuit is ideally suited for energy calculations in applications using a μ -controller or mechanical counter.

The application utilises the SAMES SA9105APA, SA9105EPA or SA9105FPA three phase power metering integrated circuits for power measurement.

The module is supplied configured to operate on 3 x 230V, 3 x 80A mains system. This can be adapted to operate on 3 x 115V, 3 x 80A mains system. Please refer to the resistor selection table shown at the end of the Application Circuit parts list.

BLOCK DIAGRAM

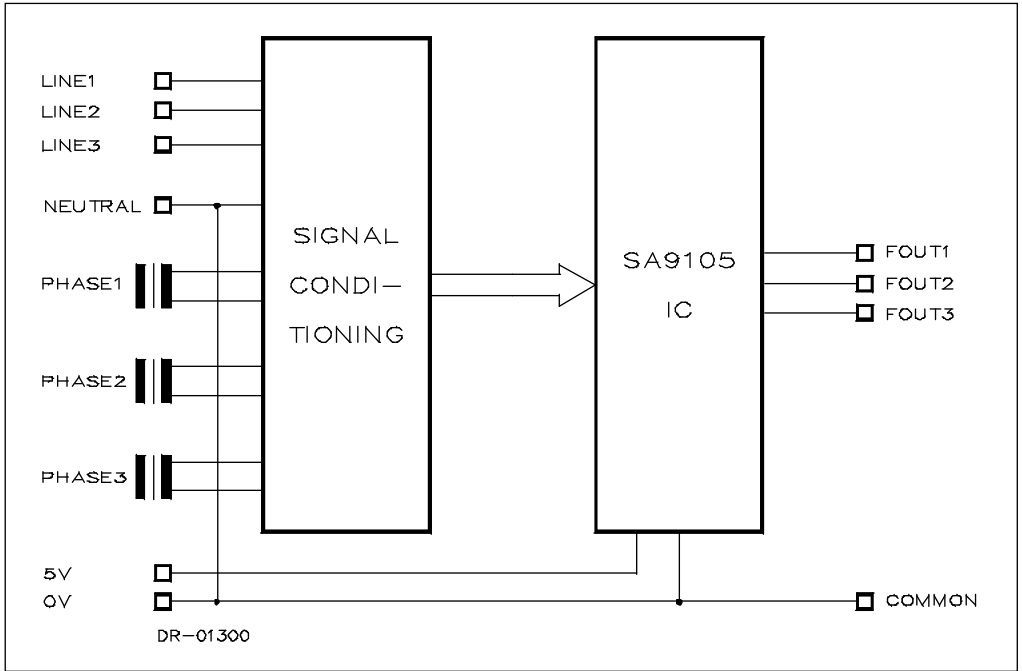

ABSOLUTE MAXIMUM RATINGS *

Parameter	Symbol	Min	Max	Unit
Supply Voltage (Note 1)	V_{AC}		540	V
Storage Temperature	T_{STG}	-25	+125	°C
Operating Temperature (Note 2)	T_o	-10	+70	°C

Note 1: Voltages are specified with reference to Neutral.

Note 2: The SA9105 integrated circuit is specified to operate over the temperature range -10°C to +70°C. The module functionality will however depend upon the external components used.

* Stresses above those listed under "Absolute Maximum Ratings" may cause permanent damage to the device. This is a stress rating only. Functional operation of the device at these or any other conditions above those indicated in the operation sections of this specification, is not implied. Exposure to Absolute Maximum Ratings for extended periods may affect device reliability.

ELECTRICAL CHARACTERISTICS

(Over the temperature range -10°C to +70°C, unless otherwise specified.)

Parameter	Symbol	Min	Typ	Max	Unit	Condition
Supply Voltage (x3 Phases) (Continuous)	V_{AC}	180	230	265	V	PM9105APE
Frequency Output	FOUTX	Refer to applicable IC data sheet				
Power Consumption ¹				100	mW	$V_{DD} = 5V$

Note 1: Power consumption specifications exclude power consumed by the current sensors.

CONNECTION DESCRIPTION

Designation	Description
PL5	Voltage Supply connected to Phase 1 Voltage Supply connected to Phase 2 Voltage Supply connected to Phase 3 Voltage Supply connected to Neutral Line (Common)
PL6	Power Output: 4Hz at rated current Power Output: 290 Hz at rated current Power Output: 1160 Hz at rated current 0V (Common)
PL4	5V DC Supply Voltage 0V DC Supply Voltage
CT1	Phase 1 (Direction indicated on PCB)
CT2	Phase 2 (Direction indicated on PCB)
CT3	Phase 3 (Direction indicated on PCB)

FUNCTIONAL DESCRIPTION

1. Power Calculation

In the Application Circuit (see Figure 2), the output currents from the current sensors will be between 0 and 16 μ A. The current input stages saturate at input currents greater than 18 μ A_{RMS}. The mains voltage (mains voltage + 15% - 20%) is used for the power calculation, together with the current information from the current sensors (current transformers).

The calculated power for the 3 phases is integrated over time and converted into a corresponding frequency.

For rated conditions, the signals into the current and voltage sensor inputs are set as follows:

Current sensor input currents: $16\mu A_{RMS}$

Voltage sensor input currents: $14\mu A_{RMS}$

Under these conditions, the device generates a pulse rate of 1.16kHz at output FOUT1.

2. Electrostatic Discharge (ESD) Protection

The device's inputs/outputs are protected against ESD. The modules resistance to transients will be dependant upon the protection components used.

3. Power Consumption

The overall power consumption rating for this power metering application (Figure 2), is under 500mW, excluding the current sensors.

4. Isolation

The reference for the unit is connected to neutral.

5. Circuit Description

The module is supplied from an external 5V DC supply.

The Application Circuit (figure 2), details the components required for a three phase power metering module. Terminated current transformers are used as current sensors.

The most important external components are:

C_7 , C_9 , C_{10} and C_{11} are the outer loop capacitors for the integrated oversampling A/D converters. The typical value of C_7 is 2.2nF and the value of C_9 , C_{10} and C_{11} is 560pF.

The actual values determine the signal to noise and stability performance. The tolerances should be within $\pm 10\%$.

C_4 , C_5 , C_6 and C_8 are the inner loop capacitors for the integrated oversampling A/D converters. The typical value of C_4 , C_5 , C_6 and C_8 is 3.3nF. Values smaller than 0.5nF and larger than 5nF should be avoided.

Terminated current sensors (current transformers) are connected to the current sensor inputs of the SA9105 through current setting resistors ($R_8 \dots R_{13}$).

The resistor values should be selected for an input current of $16\mu A$ into the SA9105 at the rated line current.

The values of these resistors should be calculated as follows:

Phase 1:

$$R_8 = R_9 = (I_{L1}/16\mu A) \times R_{18}/2$$

Phase 2:

$$R_{10} = R_{11} = (I_{L2}/16\mu A) \times R_{19}/2$$

Phase 3:

$$R_{12} = R_{13} = (I_{L3}/16\mu A) \times R_{20}/2$$

Where I_{LX} = Secondary CT current at rated conditions.

R_{18} , R_{19} and R_{20} = Termination resistors of the three current transformers.

$R_1 + R_{1A}$, R_4 and R_{15} set the current for the phase 1 voltage sense input. $R_2 + R_{2A}$, $R_5 + P_5$ and R_{16} set the current for phase 2 and $R_3 + R_{3A}$, $R_6 + P_6$ and R_{17} set the current for Phase 3. The values should be selected so that the input currents into the voltage sense inputs (virtual ground) is set to $14\mu A$ at nominal line voltage. Capacitors C1, C2 and C3 are for decoupling and phase compensation.

$R_{14} + P_{14}$ defines all on-chip bias and reference currents. With $R_{14} + P_{14} = 24k\Omega$, optimum conditions are set. P_{14} may be varied within $\pm 10\%$ for calibration purposes. Any changes to R_{14} will affect the output quadratically (i.e. $\Delta R = +5\%$, $\Delta FOUT = +10\%$).

XTAL is a colour burst TV crystal ($f = 3.5795$ MHz) for the oscillator. The oscillator frequency is divided down to 1.7897 MHz on-chip to supply the digital circuitry and the A/D converters.



Figure 1: Connection Diagram

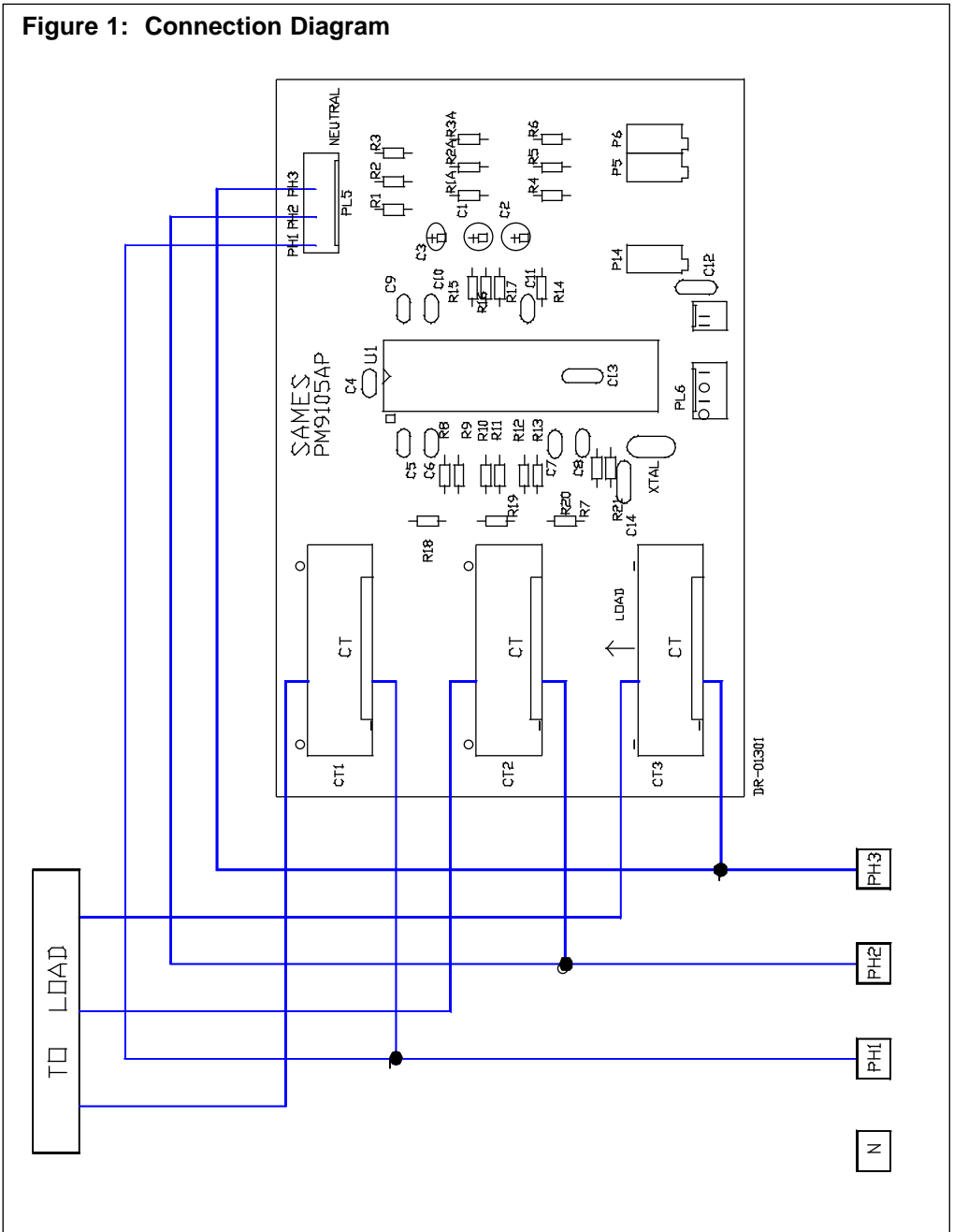
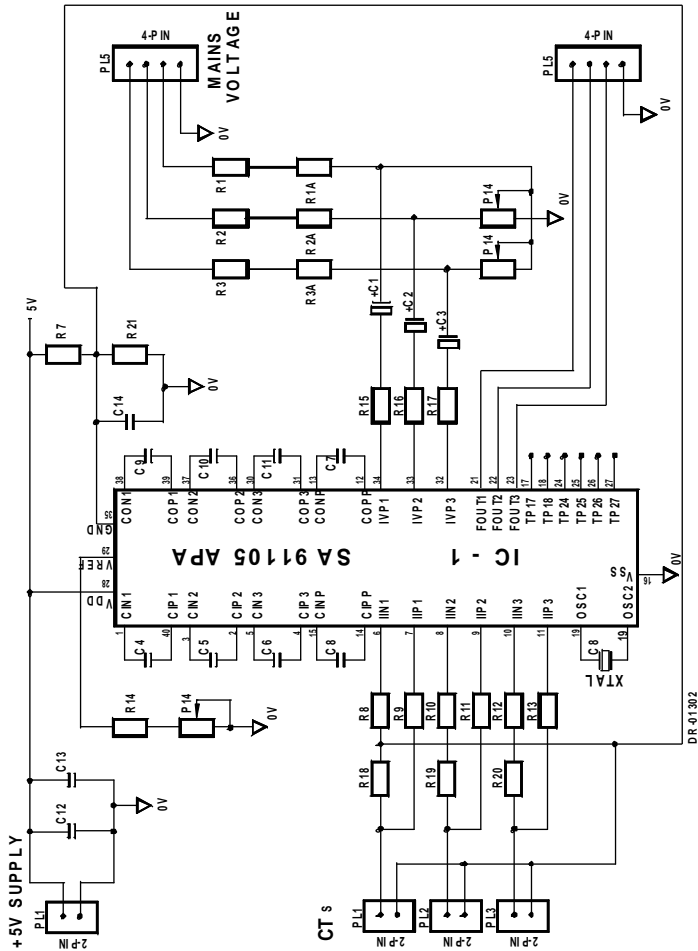

Figure 2: Application for Three Phase Power/Energy Measurement.



Parts List for Application Circuit: Figure 2

Item	Symbol	Description	Detail
1	IC-1	SA9105APA/SA9105EPA/SA9105FPA	DIP-40
2	XTAL	Crystal, 3.5795 MHz	TV Crystal
3	R1	Resistor, 1%, ¼W, Metal	Note 4
4	R1A	Resistor, 1%, ¼W, Metal	Note 4
5	R2	Resistor, 1%, ¼W, Metal	Note 4
6	R2A	Resistor, 1%, ¼W, Metal	Note 4
7	R3	Resistor, 1%, ¼W, Metal	Note 4
8	R3A	Resistor, 1%, ¼W, Metal	Note 4
9	R4	Resistor, 24k, 1%, ¼W, Metal	
10	R5	Resistor, 22k, 1%, ¼W, Metal	
11	R6	Resistor, 22k, 1%, ¼W, Metal	
12	R7	Resistor, 820Ω, 1%, ¼W, Metal	
13	R8	Resistor, 2.7k, 1%, ¼W, Metal	Note 1
14	R9	Resistor, 2.7k, 1%, ¼W, Metal	Note 1
15	R10	Resistor, 2.7k, 1%, ¼W, Metal	Note 1
16	R11	Resistor, 2.7k, 1%, ¼W, Metal	Note 1
17	R12	Resistor, 2.7k, 1%, ¼W, Metal	Note 1
18	R13	Resistor, 2.7k, 1%, ¼W, Metal	Note 1
19	R14	Resistor, 22k, 1%, ¼W, Metal	
20	R15	Resistor, 1M, 1%, ¼W, Metal	
21	R16	Resistor, 1M, 1%, ¼W, Metal	
22	R17	Resistor, 1M, 1%, ¼W, Metal	
23	R18	Resistor, 2.7Ω, 1%, ¼W, Metal	Note 1
24	R19	Resistor, 2.7Ω, 1%, ¼W, Metal	Note 1
25	R20	Resistor, 2.7Ω, 1%, ¼W, Metal	Note 1
26	R21	Resistor, 820Ω, 1%, ¼W, Metal	
27	P5	Potentiometer, 4.7k	Multi turn
28	P6	Potentiometer, 4.7k	Multi turn
29	P14	Potentiometer, 4.7k	Multi turn
30	C1	Capacitor, electrolytic, 1μF, 16V	Note 2
31	C2	Capacitor, electrolytic, 1μF, 16V	Note 2
32	C3	Capacitor, electrolytic, 1μF, 16V	Note 2
33	C4	Capacitor, ceramic, 3.3nF	
34	C5	Capacitor, ceramic, 3.3nF	
35	C6	Capacitor, ceramic, 3.3nF	
36	C7	Capacitor, ceramic, 2.2nF	
37	C8	Capacitor, ceramic, 3.3nF	
38	C9	Capacitor, ceramic, 560pF	
39	C10	Capacitor, ceramic, 560pF	
40	C11	Capacitor, ceramic, 560pF	



Parts List for Application Circuit: Figure 2 (Continued)

Item	Symbol	Description	Detail
41	C12	Capacitor, ceramic, 100nF	
42	C13	Capacitor, ceramic, 820nF	Note 3
43	C14	Capacitor, ceramic, 100nF	

Note 1: Resistor (R_8 , R_9 , R_{10} , R_{11} , R_{12} and R_{13}) values are dependant upon the selected values of the current transformer termination resistors R_{18} , R_{19} and R_{20} .

Note 2: Capacitor values may be selected to compensate for phase errors caused by the current transformers

Note 3: Capacitor (C13) to be positioned as close to Supply Pins (V_{DD} & V_{SS}) of IC-1, as possible.

Note 4: See the table below detailing the component values for the selected voltage standard.

Item	Symbol	Description		Detail
		230V	115V *	
3	R1	200k Ω	120k Ω	
4	R1A	180k Ω	82k Ω	
5	R2	200k Ω	120k Ω	
6	R2A	180k Ω	82k Ω	
7	R3	200k Ω	120k Ω	
8	R3A	180k Ω	82k Ω	

* If module is required for 115V operation, the resistors in the above table must be changed to the values shown.

ORDERING INFORMATION

Part Number	Description
PM9105AP	3 X 230V, 3 X 80A Module



Disclaimer: The information contained in this document is confidential and proprietary to South African Micro-Electronic Systems (Pty) Ltd ("SAMES") and may not be copied or disclosed to a third party, in whole or in part, without the express written consent of SAMES. The information contained herein is current as of the date of publication; however, delivery of this document shall not under any circumstances create any implication that the information contained herein is correct as of any time subsequent to such date. SAMES does not undertake to inform any recipient of this document of any changes in the information contained herein, and SAMES expressly reserves the right to make changes in such information, without notification, even if such changes would render information contained herein inaccurate or incomplete. SAMES makes no representation or warranty that any circuit designed by reference to the information contained herein, will function without errors and as intended by the designer.

South African Micro-Electronic Systems (Pty) Ltd

P O Box 15888, Lynn East, 0039 Republic of South Africa,	33 Eland Street, Koedoespoort Industrial Area, Pretoria, Republic of South Africa
---	--

Any Sales or technical questions may be posted to our e-mail address below:
info@sames.co.za

For the latest updates on datasheets, please visit our web site:
<http://www.sames.co.za>

Tel: 012 333-6021	Tel: Int +27 12 333-6021
Fax: 012 333-8071	Fax: Int +27 12 333-8071

