

WESTCODE SEMICONDUCTORS

Technical
 Publication
TP042R
 Issue 2
 April 1985

Inverter Grade Stud-Base Thyristor Type P042R

50 amperes average: up to 800 volts V_{RRM}/V_{DRM}

Ratings (Maximum values at 125°C T_j unless stated otherwise)

T-25-17

RATING	CONDITIONS	SYMBOL	
Average on-state current	Half sine wave 85°C case temperature	$I_T(AV)$	50 A
R.M.S. on-state current		$I_T(RMS)$	100 A
Continuous on-state current		I_T	100 A
Peak one-cycle surge (non-repetitive) on state current	10ms duration, 80% V_{RRM} re-applied	$I_{TSM}(1)$	750 A
	10ms duration, $V_R \leq 10$ volts	$I_{TSM}(2)$	863 A
Maximum permissible surge energy	10ms duration, $V_R \leq 10$ volts	$I^2t(2)$	3724 A ² s
	3ms duration, $V_R \leq 10$ volts	I^2t	2734 A ² s
Peak forward gate current	Anode positive with respect to cathode	I_{FGM}	5 A
Peak forward gate voltage	Anode positive with respect to cathode	V_{FGM}	25 V
Peak reverse gate voltage		V_{RGM}	5 V
Average gate power		P_G	1 W
Peak gate power	100µs. pulse width	P_{GM}	20 W
Rate of rise of off-state voltage	To 80% V_{DRM} gate open-circuit	dv/dt	*200 V/µs
Rate of rise of on-state current (repetitive)	$\left. \begin{array}{l} T_{VJ} = 125^\circ C, I_G = 3 \times I_{GT}, di_G/dt = 1 A/\mu s \\ \text{Anode voltage} \leq 80\% V_{DRM} \end{array} \right\}$	$di/dt(1)$	200 A/µs
Rate of rise of on-state current (non-repetitive)		$di/dt(2)$	400 A/µs
Operating temperature range		T_{CASE}	-30 + 125°C
Storage temperature range		T_{stg}	-40 + 125°C

Characteristics (Maximum values at 125°C T_j unless stated otherwise)

CHARACTERISTIC	CONDITIONS	SYMBOL	
Peak on-state voltage	At 157 A, I_{TM}	V_{TM}	2.03 V
Forward conduction threshold voltage		V_O	1.23 V
Forward conduction slope resistance		r	5.1 mΩ
Repetitive peak off-state current	At V_{DRM}	I_{DRM}	10 mA
Repetitive peak reverse current	At V_{RRM}	I_{RRM}	10 mA
Maximum gate current required to fire all devices	$\left. \begin{array}{l} \text{At } 25^\circ C, V_A = 6 V, \\ \end{array} \right\}$	I_{GT}	100 mA
Maximum gate voltage required to fire all devices		V_{GT}	3 V
Maximum holding current		I_H	400 mA
Maximum gate voltage which will not trigger any device		V_{GO}	0.25 V
Stored charge	$I_{TM} = 50 A, di/dt = 5 A/\mu s$ $V_{RM} = 50 V, 50\% \text{ chord value}$	Q_{rr} typical	18 µC
Circuit commutated turn-off time available down to	$I_{TM} = 50 A$ $di/dt = 5 A/\mu s, V_{RM} = 50V \text{ } 200V/\mu s \text{ to } 80\% V_{DRM}$	t_q	20-25 µs
Thermal resistance, junction to case for a device with a maximum forward volt drop characteristic		$R_{\theta(j-c)}$	0.45°C/W
Thermal resistance case to heatsink		$R_{\theta(c-h)}$	0.1°C/W

VOLTAGE CODE		H02	H04	H06	H08			
Repetitive peak voltages	$V_{RRM} V_{DRM}$	200	400	600	800			
Non-repetitive peak off-state voltage	V_{DSM}							
Non-repetitive peak reverse blocking voltage	V_{RRM}	300	500	700	900			

Ordering Information (Please quote device code as explained below)

P 0 4 2 R	● ● ●	●	●
Voltage Code (see ratings)	dv/dt code to 80% V_{DRM} C = 20V/µs E = 100V/µs D = 50V/µs F = 200V/µs	Turn-off time J = 25 µs K = 20 µs	0

Typical code: P042RH08FJ0 = 800 V_{RRM} 800 V_{DRM} 200 V/µs dv/dt to 80% V_{DRM} 25 µs turn-off
 *Other values of dv/dt up to 1000 V/µs, and turn-off time may be available.

1. INTRODUCTION

The P042R thyristor series are diffused regenerative gate devices employing a 9.5 mm slice in a stud based top-hat housing.

2. NOTES ON THE RATINGS

(a) Rate of rise of on-state current

The maximum un-primed rate of rise of on-state current must not exceed 400 A/ μ s at any time during turn-on on a non-repetitive basis. For repetitive performance the on-state rate of rise of current must not exceed 200 A/ μ s at any time during turn-on. Note that these values of current rate of rise apply to the circuit external to the device and its specified snubber network and device current rates of rise will be higher.

(b) Square wave ratings

These ratings are given for leading edge linear rates of rise of forward current of 25, 50, 100 and 200 A/ μ s.

(c) Maximum operating Frequency

The maximum operating frequency, f_{max} , is set by the time required for the thyristor to turn off (t_q) and for the off-state voltage to reach full value (t_v), i.e.

$$f_{max} = \frac{1}{t_{pulse} + t_q + t_v}$$

(d) Energy per pulse characteristics

These curves enable rapid estimation of device dissipation to be obtained for conditions not covered by the frequency ratings.

Let E_p be the Energy per pulse for a given current and pulse width, in joules.

$$\text{Then } W_{AV} = E_p \times f.$$

3. REVERSE RECOVERY LOSS

On account of the number of circuit variables affecting reverse recovery voltage, no allowance for reverse recovery loss has been made in these ratings. The following procedure is recommended for use where it is necessary to include reverse recovery loss.

(a) Determination by Measurement

From waveforms of recovery current obtained from a high frequency shunt (see Note 1) and reverse voltage present during recovery, an instantaneous reverse recovery loss waveform must be constructed. Let the area under this waveform be A joules per pulse. A new case temperature can then be evaluated from:

$$T_{CASE} \text{ (new)} = T_{CASE} \text{ (original)} - A \left(\frac{r_t \cdot 10^8}{t} + R_{th} \times f \right)$$

$$\text{where } r_t = 1.36 \times 10^{-3} \sqrt{t}$$

t = duration of reverse recovery loss per pulse in microseconds

A = Area under reverse loss waveform per pulse in joules (W.S.)

f = rated frequency at the original case temperature

The total dissipation is now given by

$$W_{(TOT)} = W_{(original)} + A \times f$$

(b) Design Method

In circumstances where it is not possible to measure voltage and current conditions, or for design purposes, the additional losses may be estimated from figure 6. A typical R-C snubber network is connected across the thyristor to control the transient reverse voltage waveform.

Let E be the value of energy per reverse cycle in joules (figure 6).

Let f be the operating frequency in Hz

$$\text{then } T_{CASE \text{ new}} = T_{CASE \text{ original}} - ER_{th} \times f$$

where $T_{CASE \text{ new}}$ is the required maximum case temperature

and $T_{CASE \text{ original}}$ is the case temperature given with the frequency ratings.

4. GATE DRIVE

The recommended gate drive is $I_G = 3I_{GT}$ with a short-circuit current rise time of not more than 0.3 μ s. This gate drive must be applied when using the full di/dt capability of the device.

5. THE DV/DT SUPPRESSION NETWORK

Snubber Network Values

A series connected C-R filter may be required across the anode to cathode terminals of the thyristor for the purpose of reducing off-state voltage overshoot.

The optimum values for C and R depend partly on the circuits connected to the thyristor. For most applications the snubber design values should not exceed a maximum of 0.25 μ F or a minimum of 10 ohms. Please consult Westcode for values outside these limits.

6. NOTE 1

REVERSE RECOVERY LOSS BY MEASUREMENT

This thyristor has a low reverse recovered charge and peak reverse recovery current. When measuring the charge care must be taken to ensure that:

- a.c. coupled devices such as current transformers are not affected by prior passage of high amplitude forward current.
- The measuring oscilloscope has adequate dynamic range — typically 100 screen heights — to cope with the initial forward current without overload.

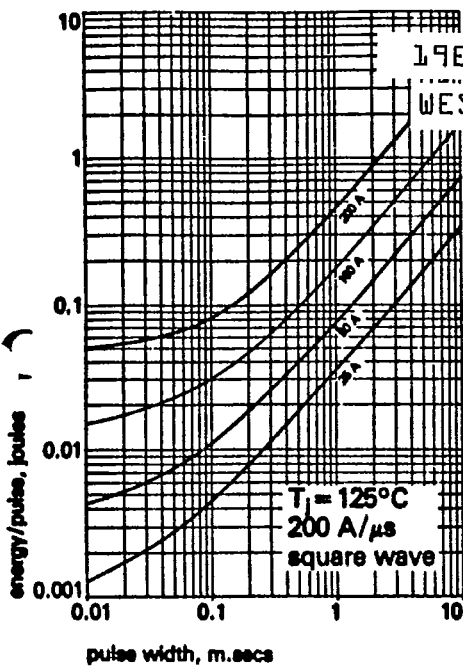

Figure 1 Energy/pulse v. pulse width

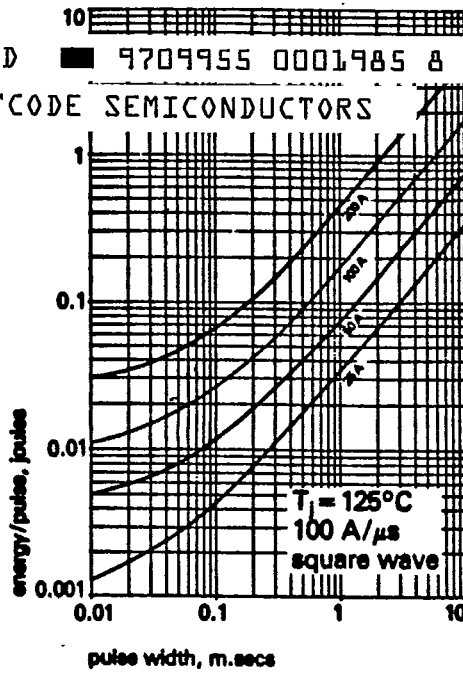

Figure 2 Energy/pulse v. pulse width

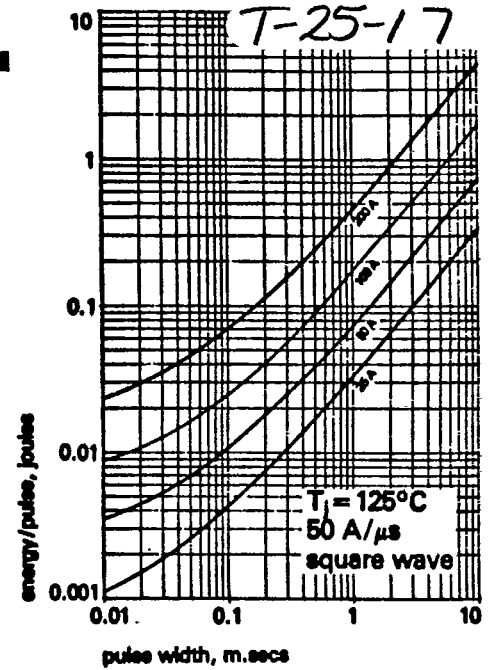

Figure 3 Energy/pulse v. pulse width

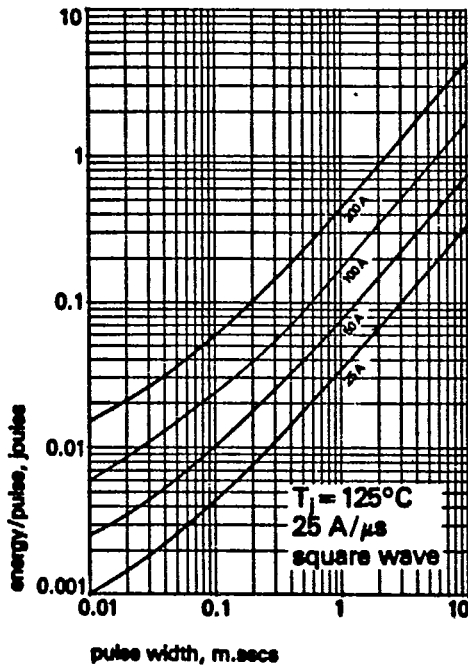

Figure 4 Energy/pulse v. pulse width

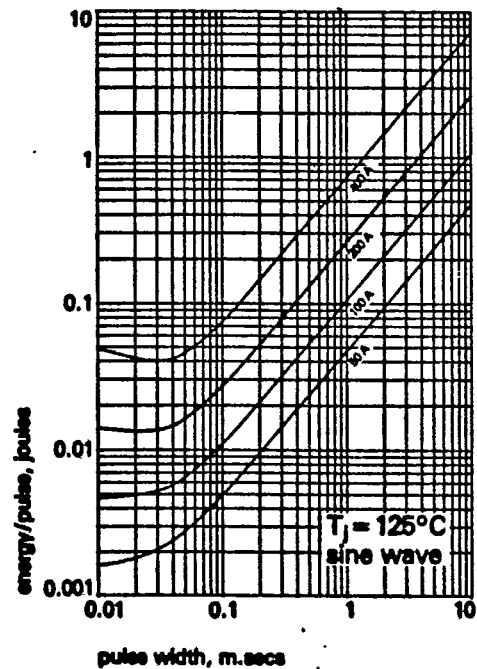

Figure 5 Energy/pulse v. pulse width

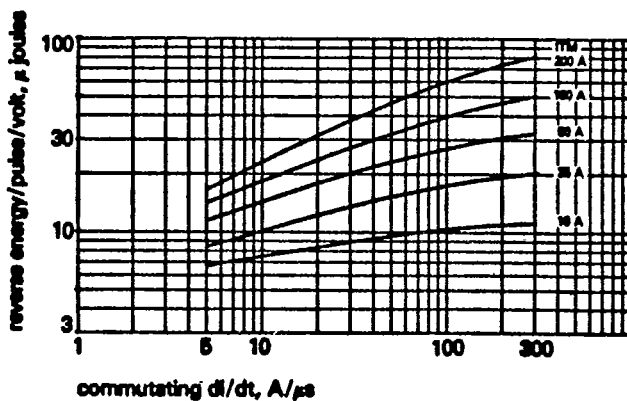

Figure 6 Max. reverse recovery energy loss per pulse at 125°C junction temperature

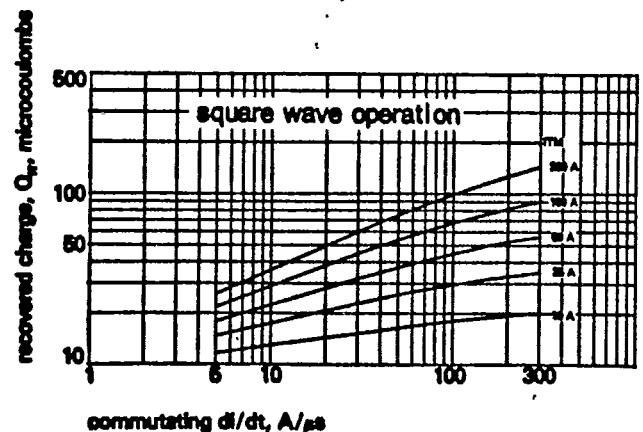

Figure 7 Typical recovered charge at 125°C junction temperature

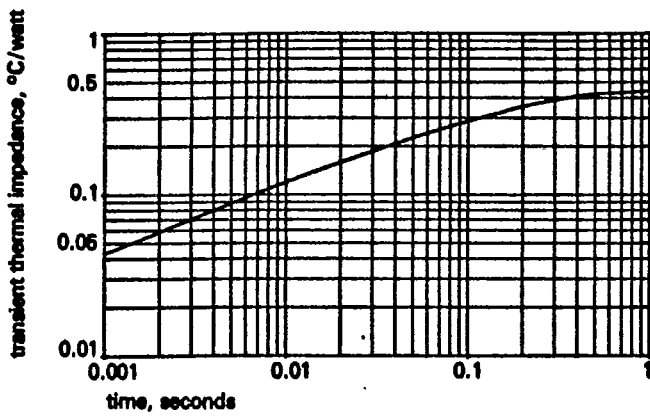

Figure 8 Junction to heat sink transient thermal impedance

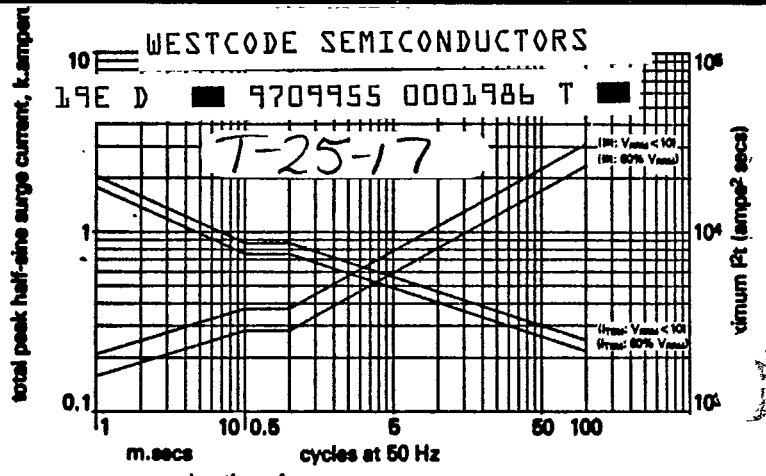

Figure 9 Max. non-repetitive surge current at initial junction temperature 125°C. Gate may temporarily lose control of conduction angle. Note: This rating must not be interpreted as an intermittent rating.

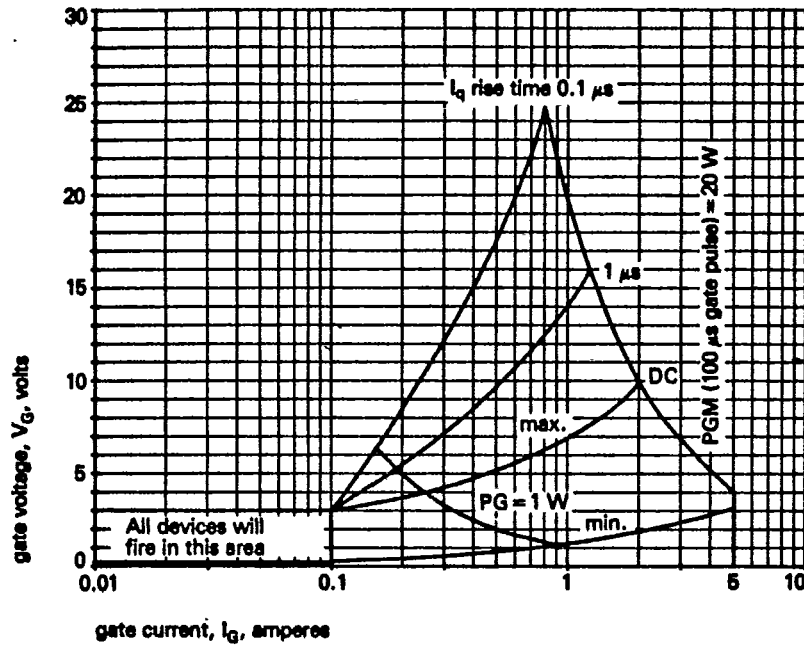

Figure 10 Gate characteristics at 25°C junction temperature

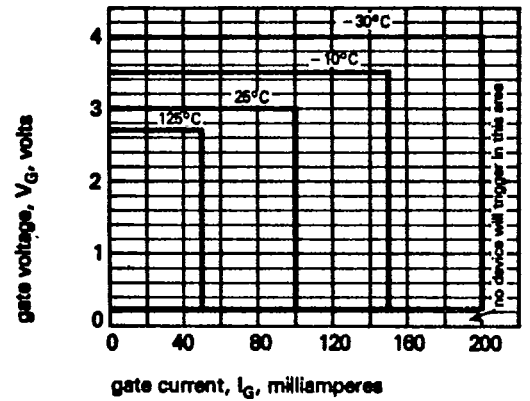

Figure 11 Gate trigger characteristics. Trigger points of all thyristors lie within the areas shown.

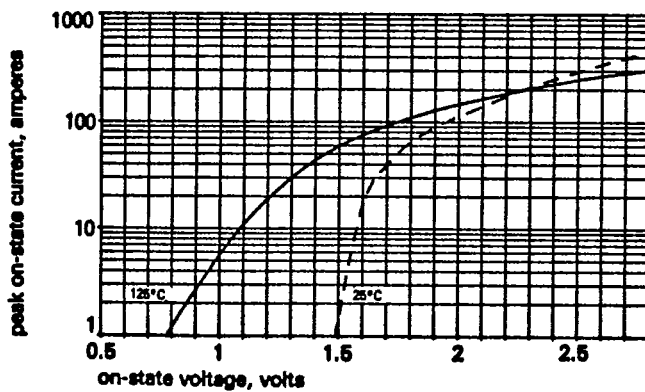
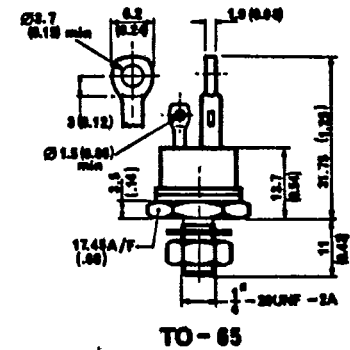

Figure 12 Limit on-state characteristic



Dimensions in mm (inches)
Mounting Torque: 0.41—0.48 Kgm
Threads not to be lubricated
Weight: 33 grams

In the interest of product improvement, Westcode reserves the right to change specifications at any time without notice.

WESTCODE SEMICONDUCTORS LTD

P.O. Box 57 Chippenham Wiltshire SN15 1JL England
Telephone Chippenham (0249) 654141 Telex 44751

HAWKER SIDDELEY

Westinghouse Brake and Signal Co. Ltd.