

# 2.5Gb/s Optical Transmitter for DWDM

## OAS25323 Series

1

Document Number QPS-0202-091

### OAS25323 Series

Document Number QPS-0202-091

Revision 0.2

DATE: Jan. 16, 2003

Author S.OKABE

Project Manager K. YUSA

### Part Number

OAS25323x-NV-WDM-yy-zz

#### *Modification History*

Rev.	Date	Originator	Comments, Modifications
DRAFT0.1	Dec. 24, 2002	S.OKABE	
DRAFT0.2	Jan. 16, 2003	T.Ida	

#### *Features*

- Center Wavelength range: 1528.77 to 1563.86nm ITU-T G.692 100GHz channel spacing
- High output Power +1dBm(Typ)
- Selection of Clocked or non-clocked operation
- Supply voltage: +3.3V and +5V

#### *Application*

- SONET and ITU-T compliant at OC-48 and STM-16 for DWDM

# 2.5Gb/s Optical Transmitter for DWDM

## OAS25323 Series

### 1. Specifications

**Table 1.1 Specifications** (Vcc = +5.0V±5%, Tc=0 to 70°C)

Parameter	Unit	Values
Mean launched power range	dBm	-3 to +4
Maximum Operating Bit Rate	Gbps	2.488
Center wavelength range Wavelength channel spacing	nm	1528.77 to 1563.86 ITU-T G.692 100GHz channel spacing
Center wavelength accuracy	nm	≤ ± 0.015
Variation center wavelength over temperature	nm	≤ ± 0.05
Maximum spectral width [20dB down]	nm	0.3(Typ) , 0.5(Max)
Minimum side mode suppression ratio	dB	≥ 30
Center wavelength aging BOL to EOL	nm	≤ ± 0.1
Minimum extinction ratio	dB	≥ 8.2
Optical output waveform		Meets for ITU-T G.957
Maximum Fiber Dispersion	ps/nm	≤ 6400
Dispersion penalty	dB	≤ 2
Power consumption	W	≤ 5.5
Operating case temperature range	°C	Tc=0 to +70
Operating humidity	%	0 to 85
Dimension	mm	73.4 x 51 x 11.9

**Table 1.2 Absolute Maximum Ratings**

Parameter	Symbol	Condition	Min	Max	Unit
Supply voltage Vcc +5V pin	Vcc	Tc=+25°C	-0.5	+7	V
Supply voltage VTEC+3.3V pin	VTEC		-0.5	+4.6	V
Maximum signal input voltage (Clock/Data)	V <sub>I</sub>		0	Vcc	V
Maximum signal output current (TDA pin)	I <sub>O</sub>	-	-25	+25	mA
Operating case temperature range	T <sub>OP</sub>		-20	+85	°C
Storage temperature range	T <sub>STG</sub>		-40	+85	°C
Lead soldering temperature/time	-		-	260/10	C/s
Tensile strength of fiber pigtail cable	-	Tc=+25°C	-	500	g
Minimum bending radius of fiber pigtail cable	-		30		mm

**Table 1.3 Electrical Specifications (V<sub>cc</sub> = +5.0V±5%, T<sub>c</sub> = +25°C)**

Parameter	Symbol	Min	Typ	Max	Unit	
Power supply voltage	V <sub>cc</sub>	+4.75	+5.00	+5.25	V	
Power supply current	I <sub>CC</sub>	-	450	500	mA	
TEC power supply Voltage	V <sub>TEC</sub>	+3.0	+3.3	+3.5	V	
TEC power supply current	I <sub>TEC</sub>	-	0.4	1.0	A	
Data/Clock Input Amplitude [AC- Coupled at Internal]	Single end	V <sub>in-single</sub>	250	-	1300	mVp-p
	Differential	V <sub>in-diff.</sub>	125	-	650	
Input impedance	R <sub>INRoad</sub>	-	50	-	ohm	
Clock mode Select input Voltage	Clocked	V <sub>CLK ON</sub>	0	-	+0.8	V
	Non Clocked	V <sub>NON CLK</sub>	2.0	-	V <sub>cc</sub>	V
Wavelength Selection input Voltage	n	V <sub>λn</sub>	0	-	+0.8	V
	n-1	V <sub>λn-1</sub>	2.0	-	V <sub>cc</sub>	V
Shut Down input Voltage	Enable	V <sub>EN</sub>	0	-	+0.8	V
	Disable	V <sub>DIS</sub>	2.0	-	V <sub>cc</sub>	V
TEC Temperature deviation error Monitor (Active High)	Normal	V <sub>OL</sub>	0	-	+0.3	V
	Deviation	V <sub>OH</sub>	+4.5	-	V <sub>cc</sub>	V
	Setting Level	λ <sub>alarm</sub>	-1	-	+1	C
Laser Degrade Alarm (Active Low) <sup>3</sup>		V <sub>OL</sub>	0	-	+0.3	V
		V <sub>OH</sub>	+4.5	-	V <sub>cc</sub>	V
LD Bias monitor <sup>3</sup>	V <sub>LBM</sub>	-	20	-	mV/mA	
Back facet Monitor	V <sub>BF</sub>	-	500	-	mV/mW	
DATA/CLOCK input Rise/Fall time <sup>1</sup>	t <sub>R</sub> /t <sub>F</sub>	-	-	0.12	ns	
DATA/CLOCK timing <sup>2</sup>	t <sub>s</sub> /t <sub>h</sub>	50	-	-	psec	
Input Clock Pulse width distortion	-	40	50	60	%	

1. Between 20% and 80%
2. The data and clock timing diagram is Figure 1.1
3. See Table 4.1

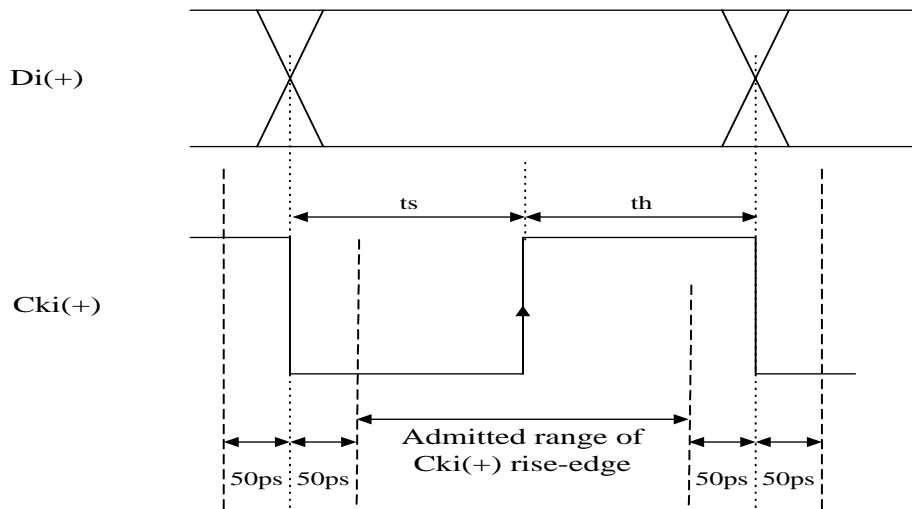

**Figure 1.1 Data/Clock Timing Diagram**

**2. Block Diagram**

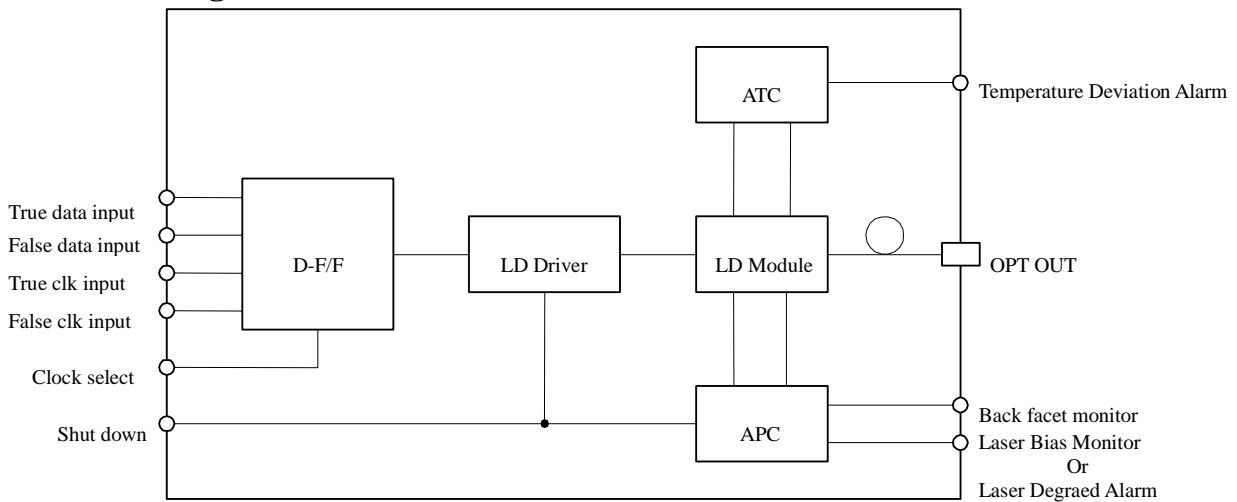

**Figure 2.1 Block Diagram**

3. Package Outline (Unit : mm)

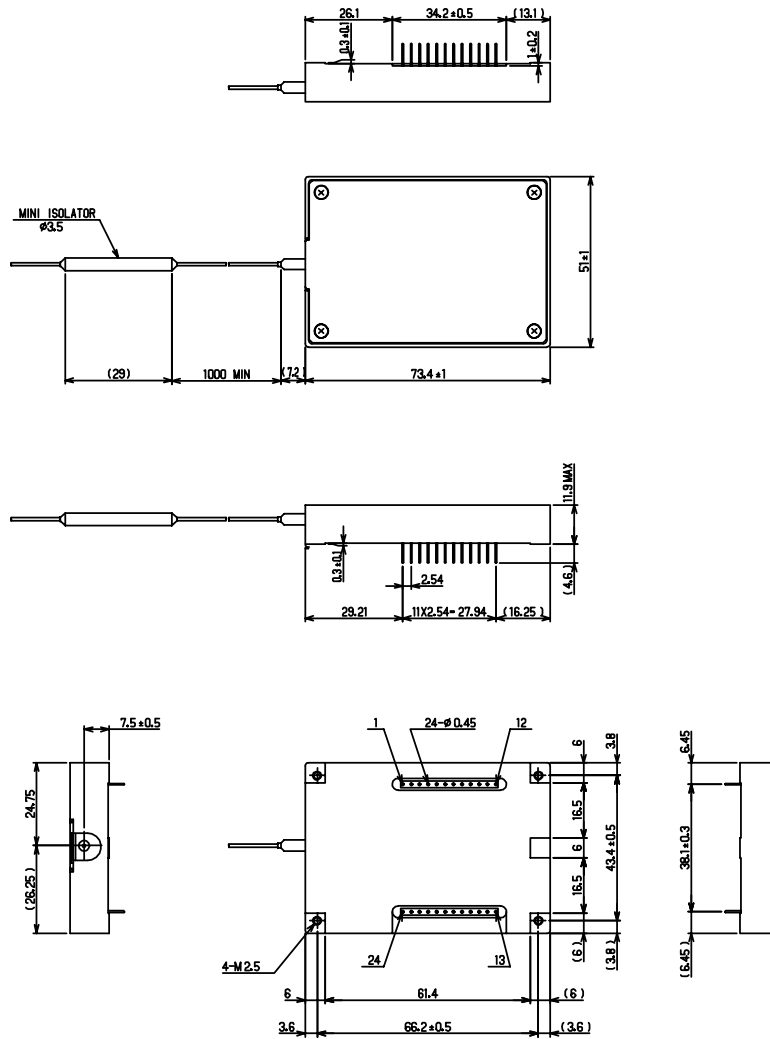

Figure 3.1 Package Outline

**4. Pin Descriptions**

**Table 4.1 pin Descriptions**

No.	Symbol	Functionality	No.	Symbol	Functionality
01	GND	Ground ( TEC )	13	VCC	Positive power supply +5.0V
02	BACK(+)	Back facet Monitor	14	VTEC	TEC supply voltage +3.3V
03	BIAS(+)/LDA	Laser Bias Monitor or Laser Degraed Alarm(TTL,Active"Lo") <sup>1</sup>	15	GND	Ground
04	SDC	Shut Down Command(TTL, Open/Lo=Operating , Hi=Shutdown)	16	Di(+)	True data input
05	SELC	Clock mode Select(TTL, Open/Lo=CLK , Hi=CLK unuse)	17	GND	Ground
06	GND	Ground	18	Di(-)	False data input
07	TDA	Temperature Deviation ALM (TTL,Active"High")	19	GND	Ground
08	NC	No User Connection	20	Cki(+)	True clock input
09	NC	No User Connection	21	GND	Ground
10	NC	No User Connection	22	Cki(-)	False clock input
11	GND	Ground	23	GND	Ground
12	NIC	No Internal Connection	24	VCC	Positive power supply +5.0V

1. Laser Bias Monitor and Laser Degraed Alarm functions are customer select options .

**5. Recommended Interface Circuit**

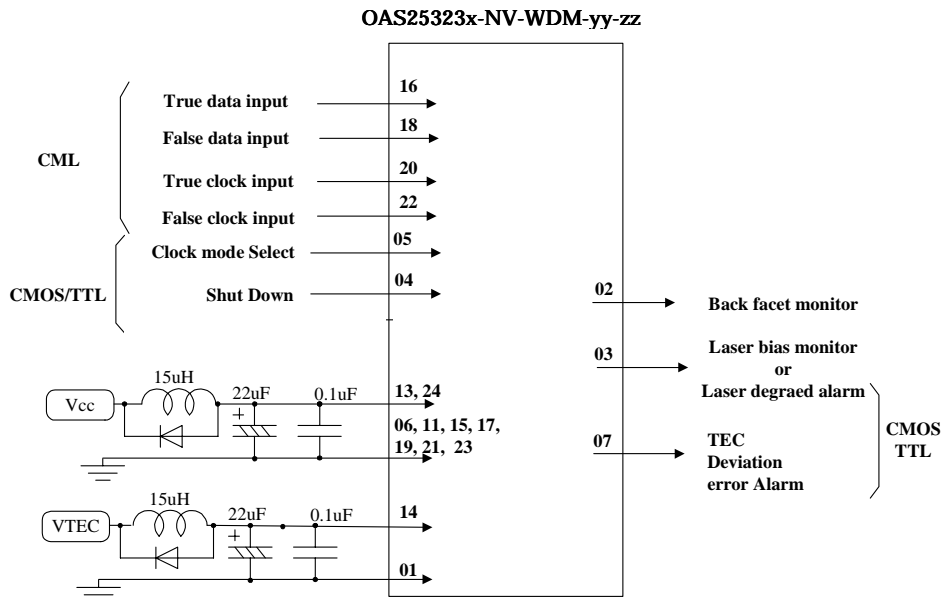

**Figure 5.1 Recommended Interface Circuit**

### **6. Precautions for handling**

The circuits of these modules operate at very small signal. In order to avoid the degradation of the optical sensitivity due to external noise, the bottom pattern of these modules on the PCB should be ground pattern with low impedance.

Do not mount/pattern device/circuits which generate high frequency noise close to the module.

In order to operate the module stable against the power noise, install the power supply noise reduction circuits.

The impedance between the power and ground pattern of the power circuit should be as low as possible. The elements around the module should be mounted close to the pins of the module.

If an optical power exceeding the absolute maximum ratings is fed to the module, the optical receiver may be damaged. Set the optical input power appropriately when in use of these modules.

### **7. Qualification and Reliability**

To help ensure high product reliability and customer satisfaction, OKI is committed to an intensive quality program that starts in the design phase and proceeds through the manufacturing process.

Optical transceiver modules are qualified to OKI internal standards using MIL-STD-883 test methods and procedures and using sample techniques consistent with Telcordia requirements.

This qualification program fully meets the intent of Telcordia reliability practices GR-468-CORE.

### **8. Laser Safety**

All version of transceiver are Class 1 Laser products FDA complies with 21 CFR 1040.10 and 1040.11 requirements.

Also, all versions are Class 1 Laser products pre IEC 825-1.

# 2.5Gb/s Optical Transmitter for DWDM

## OAS25323 Series

### 9. Ordering Information

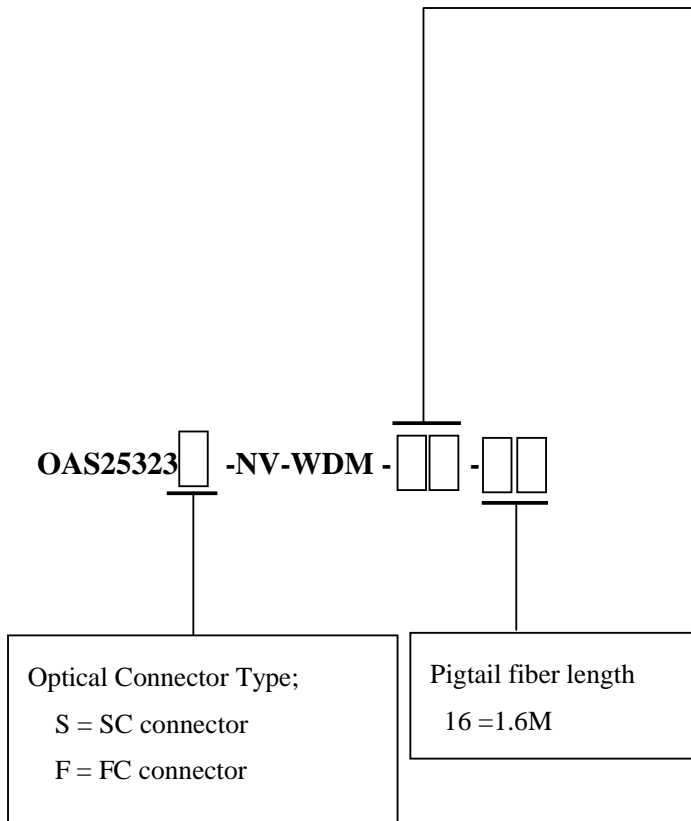

No.	ITU-T FurequencyTHz	Center wavelength
61	196.1	1528.77
60	196.0	1529.55
59	195.9	1530.33
58	195.8	1531.12
57	195.7	1531.90
56	195.6	1532.68
55	195.5	1533.47
54	195.4	1534.25
53	195.3	1535.04
52	195.2	1535.82
51	195.1	1536.61
50	195.0	1537.40
49	194.9	1538.19
48	194.8	1538.98
47	194.7	1539.77
46	194.6	1540.56
45	194.5	1541.35
44	194.4	1542.14
43	194.3	1542.94
42	194.2	1543.73
41	194.1	1544.53
40	194.0	1545.32
39	193.9	1546.12
38	193.8	1546.92
37	193.7	1547.72
36	193.6	1548.51
35	193.5	1549.32
34	193.4	1550.12
33	193.3	1550.92
32	193.2	1551.72
31	193.1	1552.52
30	193.0	1553.33
29	192.9	1554.13
28	192.8	1554.94
27	192.7	1555.75
26	192.6	1556.55
25	192.5	1557.36
24	192.4	1558.17
23	192.3	1558.98
22	192.2	1559.79
21	192.1	1560.61
20	192.0	1561.42
19	191.9	1562.23
18	191.8	1563.05
17	191.7	1563.86