

The documentation and process conversion measures necessary to comply with this revision shall be completed by 6 January 2006.

INCH-POUND

MIL-PRF-19500/117N
6 October 2005
SUPERSEDING
MIL-PRF-19500/117M
13 January 2004

PERFORMANCE SPECIFICATION SHEET

SEMICONDUCTOR DEVICES, DIODE, SILICON, VOLTAGE REGULATOR,
TYPES 1N962B-1 THROUGH 1N992B-1, AND 1N962BUR-1 THROUGH 1N992BUR-1, 1N962C-1 THROUGH
1N992C-1, AND 1N962CUR-1 THROUGH 1N992CUR-1, AND 1N962D-1 THROUGH 1N992D-1, 1N962DUR-1
THROUGH 1N992DUR-1, JAN, JANTX, JANTXV, AND JANHC

JANS level (see 6.4).

This specification is approved for use by all Departments
and Agencies of the Department of Defense.

The requirements for acquiring the product described herein shall
consist of this specification sheet and MIL-PRF-19500.

1. SCOPE

1.1 Scope. This specification covers the performance requirements for 500 milliwatt, silicon, voltage regulator diodes with voltage tolerances of 5 percent, 2 percent, and 1 percent. Three levels of product assurance are provided for each encapsulated device type as specified in MIL-PRF-19500. One level of product assurance is provided for each unencapsulated device type.

1.2 Physical dimensions. See figure 1 (similar to DO-35), figure 2 (DO-213AA), and figure 3 for (JANHC die).

* 1.3 Maximum ratings. Maximum ratings are as shown in maximum and primary test ratings (see 3.8) herein and as follows:

- a. $P_{TL} = 500$ mW, (DO-35) at $T_L = +50^\circ\text{C}$, $L = .375$ inch (9.53 mm); both ends of case or diode body to heat sink at $L = .375$ inch (9.53 mm). Derate I_Z to 0.0 mA dc at $+175^\circ\text{C}$.
- b. $P_{TEC} = 500$ mW, (DO-213AA) at $T_{EC} = +125^\circ\text{C}$, derate to 0 at $+175^\circ\text{C}$. $-65^\circ\text{C} \leq T_J \leq +175^\circ\text{C}$; $-65^\circ\text{C} \leq T_{STG} \leq +175^\circ\text{C}$.
- c. $P_{T(PCB)} = 500$ mW, $T_A = 75^\circ\text{C}$.

* Comments, suggestions, or questions on this document should be addressed to Defense Supply Center, Columbus, ATTN: DSCC-VAC, P.O. Box 3990, Columbus, OH 43218-3990, or emailed to Semiconductor@dsc.dla.mil. Since contact information can change, you may want to verify the currency of this address information using the ASSIST Online database at <http://assist.daps.dla.mil>.

* 1.4 Primary electrical characteristics. Primary electrical characteristics are as shown in maximum and primary test ratings (see 3.8) herein and as follows:

- a. $11 \text{ V dc} \leq V_Z \leq 200 \text{ V dc}$.
- b. 1N962B-1 through 1N992B-1 are 5 percent voltage tolerance.
- c. 1N962C-1 through 1N992C-1 are 2 percent voltage tolerance.
- d. 1N962D-1 through 1N992D-1 are 1 percent voltage tolerance.

Thermal resistance:

$R_{\theta JL} = 250^\circ\text{C/W}$ maximum at $L = .375$ inch (9.53 mm) (DO-35).

$R_{\theta JEC} = 100^\circ\text{C/W}$ maximum. Junction to end-caps (DO-213AA).

$R_{\theta JA(\text{PCB})} = 300^\circ\text{C/W}$ junction to ambient including PCB see note (1).

- (1) See figures 4, 5, and 6 for derating curves. $T_A = +75^\circ\text{C}$ for both axial and MELF (US) on printed circuit board (PCB), PCB = FR4 .0625 inch (1.59 mm) 1-layer 1-Oz Cu, horizontal, still air, pads (US) = .067 inch (1.70 mm) x .105 inch (2.67 mm); pads (axial) = .092 inch (2.34 mm) diameter, strip = .030 inch (7.62 mm) x 1 inch (25.4 mm) long, axial lead length $L \leq .187$ inch (≤ 4.76 mm); $R_{\theta JA(\text{PCB})}$ with a defined thermal resistance condition included is measured at $I_Z =$ as defined in the electrical characteristics tolerance table herein.

2. APPLICABLE DOCUMENTS

2.1 General. The documents listed in this section are specified in sections 3, 4, or 5 of this specification. This section does not include documents cited in other sections of this specification or recommended for additional information or as examples. While every effort has been made to ensure the completeness of this list, document users are cautioned that they must meet all specified requirements of documents cited in sections 3, 4, or 5 of this specification, whether or not they are listed.

2.2 Government documents.

2.2.1 Specifications, standards, and handbooks. The following specifications, standards, and handbooks form a part of this document to the extent specified herein. Unless otherwise specified, the issues of these documents are those cited in the solicitation or contract.

DEPARTMENT OF DEFENSE SPECIFICATIONS

MIL-PRF-19500 - Semiconductor Devices, General Specification for.

DEPARTMENT OF DEFENSE STANDARDS

MIL-STD-750 - Test Methods for Semiconductor Devices.

* (Copies of these documents are available online at <http://assist.daps.dla.mil/quicksearch/> or <http://assist.daps.dla.mil> or from the Standardization Document Order Desk, 700 Robbins Avenue, Building 4D, Philadelphia, PA 19111-5094.)

2.3 Order of precedence. In the event of a conflict between the text of this document and the references cited herein, the text of this document takes precedence. Nothing in this document, however, supersedes applicable laws and regulations unless a specific exemption has been obtained.

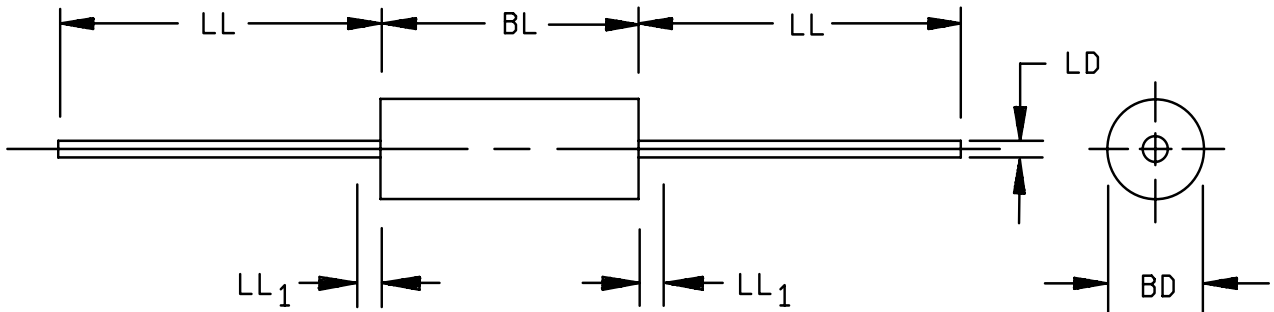

Symbol	Dimensions				Notes
	Inches		Millimeters		
	Min	Max	Min	Max	
BD	.055	.090	1.40	2.29	3
BL	.120	.200	3.05	5.08	3
LD	.018	.022	0.46	0.56	
LL	1.000	1.500	25.40	38.10	
LL1		.050		1.27	4

NOTES:

1. Dimensions are in inches.
2. Millimeters are given for general information only.
3. Package contour optional within BD and length BL. Heat slugs, if any, shall be included within this cylinder but shall not be subject to minimum limit of LD. The BL dimension shall include the entire body including slugs (new note).
4. Within LL1 lead diameter may vary to allow for flash, lead finish build-up, and minor irregularities other than heat slugs.
5. In accordance with ASME Y14.5M, diameters are equivalent to ϕX symbology.

FIGURE 1. Physical dimensions for types 1N962B-1 through 1N992B-1, 1N962C-1 through 1N992C-1, 1N962D-1 through 1N992 (DO-35).

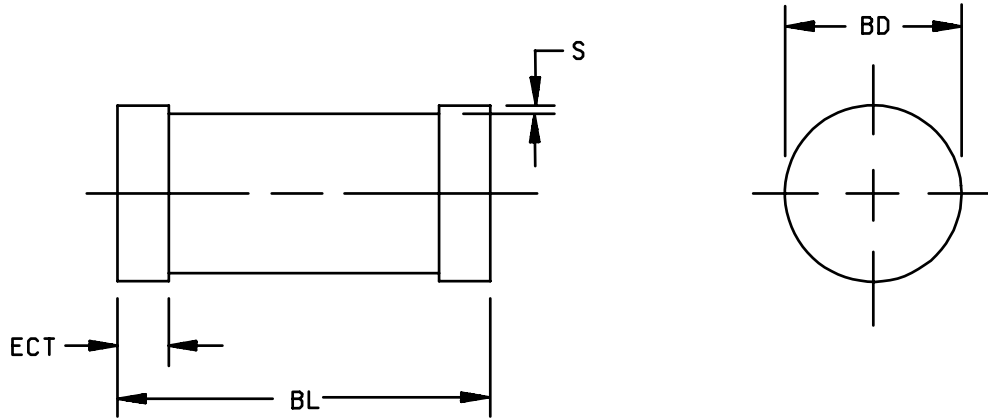

Symbol	Dimensions			
	Inches		Millimeters	
	Min	Max	Min	Max
BL	.130	.146	3.30	3.70
BD	.063	.067	1.60	1.70
ECT	.016	.022	0.41	0.55
S	.001 min		0.03 min	

NOTES:

1. Dimensions are in inches.
2. Millimeters are given for general information only.
3. In accordance with ASME Y14.5M, diameters are equivalent to ϕX symbology.

FIGURE 2. Physical dimensions for types 1N962BUR-1 through 1N992BUR-1, 1N962CUR-1 through 1N992CUR-1, 1N962DUR-1 through 1N992DUR-1 (DO-213AA).

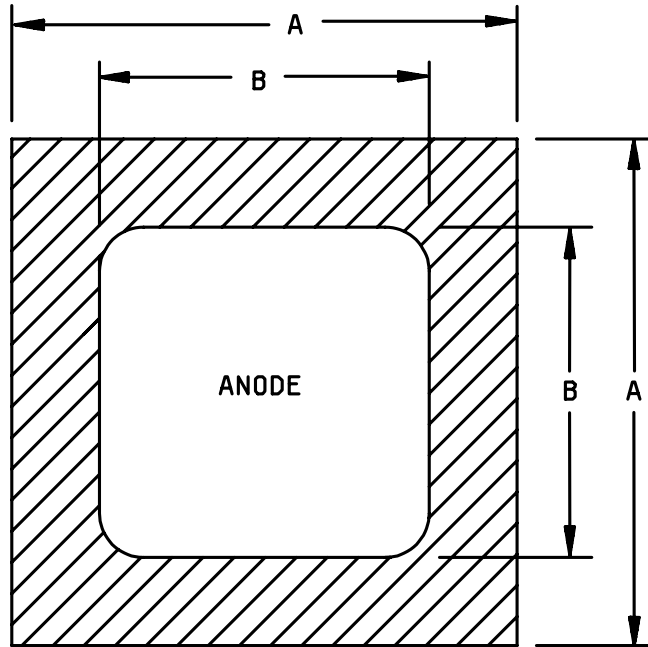

BACKSIDE IS CATHODE

Ltr	Dimensions							
	JANHCA				JANHCB			
	Inches		Millimeters		Inches		Millimeters	
	Min	Max	Min	Max	Min	Max	Min	Max
A	.021	.025	.53	.63	.024	.028	0.61	0.71
B	.013	.017	.33	.43	.017	.021	0.43	0.53

NOTES:

1. Dimensions are in inches.
2. Millimeters are given for general information only.
3. The physical characteristics of the die thickness are $.010 \pm .002$ (0.25 mm). Metallization is top = (anode)-AL, back: (cathode)-AU. AL thickness = 12,000 Å minimum for JANHCA and 40,000 Å minimum for JANHCB, AU thickness = 3,000 Å minimum for JANHCA, and 5,000 Å minimum for JANHCA.
4. Circuit layout data: For zener operation, cathode must be operated positive with respect to anode.
5. Requirements in accordance with appendix G of MIL-PRF-19500, are performed in a TO-5 package (see 6.5).

FIGURE 3. Physical dimensions (JANHCA and JANHCB die dimensions).

3. REQUIREMENTS

3.1 General. The individual item requirements shall be as specified in MIL-PRF-19500 and as modified herein.

3.2 Qualification. Devices furnished under this specification shall be products that are manufactured by a manufacturer authorized by the qualifying activity for listing on the applicable qualified manufacturer's list (QML) before contract award (see 4.2 and 6.3).

* 3.3 Abbreviations, symbols, and definitions. The abbreviations, symbols, and definitions used herein are defined in MIL-PRF-19500, and as follows.

EC - - - - - end-caps.

$R_{\theta JA}(PCB)$ - - - thermal resistance junction to ambient, with a defined printed circuit board mounting.

$R_{\theta JBB}$ Thermal resistance junction to burn-in board.

3.4 Interface and physical dimensions. The interface and physical dimensions shall be specified in MIL-PRF-19500 and figures 1 and 2 (similar to DO-35 and DO-213AA), and figure 3 (die) herein.

3.4.1 Lead finish. Lead finish shall be solderable in accordance with MIL-PRF-19500, MIL-STD-750, and herein. Where a choice of lead finish is desired, it shall be specified in the acquisition document (see 6.2).

* 3.4.2 Diode construction. All devices shall be metallurgically bonded double plug construction in accordance with the requirements of category I, II, or III (see MIL-PRF-19500).

3.5 Selection of tight tolerance devices. The C and D suffix devices shall be selected from JAN, JANTX, or JANTXV devices, which have successfully completed all applicable screening, and groups A, B, and C testing as 5 percent tolerance devices. All sublots of C and D suffix devices shall pass table I, subgroup 2, at tightened tolerances. Tighter tolerances for mounting clip temperature shall be maintained for reference purpose to establish correlation. For C and D tolerance levels, $T_L = +25^{\circ}\text{C} \pm 2^{\circ}\text{C}$ at .375 inch from body or equivalent.

3.6 Electrical performance characteristics. Unless otherwise specified herein, the electrical performance characteristics are as specified in 1.3, 1.4, and table I, II, and III.

* 3.7 Electrical test requirements. The electrical test requirements shall be the subgroups specified in table I herein.

3.8 Maximum and primary test ratings. Maximum and primary test ratings for voltage regulator diodes are specified in table IV herein.

3.9 Marking. Devices shall be marked in accordance with MIL-PRF-19500. At the option of the manufacturer, the DO-35 version may leave off "-" portion of the type designator (example: JANTX1N962B1).

3.9.1 Marking of UR-1 version devices. For UR-1 version devices only, all marking (except polarity) may be omitted from the body, but shall be retained on the initial container.

3.10 Workmanship. Semiconductor devices shall be processed in such a manner as to be uniform in quality and shall be free from other defects that will affect life, serviceability, or appearance.

4. VERIFICATION

4.1 Classification of Inspections. The inspection requirements specified herein are classified as follows:

- a. Qualification inspection (see 4.2).
- b. Screening (see 4.3).
- c. Conformance inspection (see 4.4, and table I, II, III, and IV).

4.2 Qualification inspection. Qualification inspection shall be in accordance with MIL-PRF-19500 and as specified herein.

4.2.1 JANHC devices. JANHC devices shall be qualified in accordance with appendix G of MIL-PRF-19500.

4.2.2 Construction verification. Cross sectional photos from three devices shall be submitted in the qualification report.

* 4.3 Screening (JAN, JANTX, and JANTXV levels only). Screening shall be in accordance with table IV of MIL-PRF-19500 and as specified herein. The following measurements shall be made in accordance with table I herein. Devices that exceed the limits of table I herein shall not be acceptable.

Screen (see table IV of MIL-PRF-19500)	Measurement
	JANTX and JANTXV levels
3a	Temperature cycling
(1) 3c	Thermal impedance (see 4.3.2)
7a	Not required
7b	Optional
9	Not required
11	I_{R1} and V_Z
12	See 4.3.3, $t = 48$ hours
(2) 13	$\Delta I_{R1} \leq 100$ percent of initial reading or 50 nA dc, whichever is greater. $\Delta V_Z \leq \pm 2$ percent initial reading. Subgroup 2 of table I herein.
14a	Not required
(3) 14b	Required

- (1) Thermal impedance shall be performed any time after sealing provided temperature cycling is performed in accordance with MIL-PRF-19500, screen 3 prior to this thermal test.
- (2) PDA = 5 percent for screen 13 applies to ΔI_{R1} and ΔV_Z . Thermal impedance ($Z_{\theta JX}$) is not required in screen 13.
- (3) For clear glass diodes, the hermetic seal (gross leak) may be performed at anytime after temperature cycling.

4.3.1 Screening (JANHC). Screening of JANHC die shall be in accordance with appendix G of MIL-PRF-19500.

4.3.1.1 JAN testing. JAN level product will have temperature cycling and thermal impedance testing performed in accordance with MIL-PRF-19500, JANTX level screening level requirements.

* 4.3.2 Thermal impedance. The thermal impedance measurements shall be performed in accordance with method 3101 or 4081, as applicable, of MIL-STD-750 using the guidelines in that method for determining I_M , I_H , t_H , t_{MD} (and V_C where appropriate). The thermal impedance limit shall comply with the thermal impedance graph on figures 7, 8, and 9 (less than or equal to the curve value at the same t_H time) and shall be less than the process determined statistical maximum limit as outlined in method 3101 or 4081. (See table II, subgroup 4). See figure 10 for mounting conditions.

* 4.3.3 Power burn-in conditions. Power burn-in conditions are as follows: I_{ZPCB} = column 8 of table IV; $T_A = 75^\circ\text{C}$ maximum. Test conditions in accordance with method 1038 of MIL-STD-750, condition B (see 4.5.9).

Adjust I_Z or T_A to achieve the required T_J . $T_J = 125^\circ\text{C}$ minimum.

or

Mounting condition shall be equivalent to the FR4 board (defined herein). $R_{\theta JA(PCB)} \geq R_{\theta JBB}$. Apply $I_Z = I_{ZPCB}$.

4.4 Conformance inspection. Conformance inspection shall be in accordance with MIL-PRF-19500 and as specified herein. Group A inspection shall be performed on each subplot.

4.4.1 Group A inspection. Group A inspection shall be conducted in accordance with MIL-PRF-19500, and table I herein.

4.4.2 Group B inspection. Group B inspection shall be conducted in accordance with the conditions specified for subgroup testing in table VIb (JAN, JANTX, and JANTXV) of MIL-PRF-19500 and 4.4.2.1 herein. Electrical measurements (end-points) shall be in accordance with the applicable inspections of table III herein.

* 4.4.2.1 Group B inspection, table VIb (JAN, JANTX and JANTXV) of MIL-PRF-19500.

<u>Subgroup</u>	<u>Method</u>	<u>Condition</u>
B2	1056	0°C to $+100^\circ\text{C}$, 10 cycles.
B2	1051	-55°C to $+175^\circ\text{C}$, 25 cycles.
B2	4066	See 4.5.1.
* B3	1027	I_{ZM} = column 8 of table IV (minimum). Adjust I_Z or T_A to achieve $T_J = 150^\circ\text{C}$ minimum (see 4.5.9).
B4	2101	Decap analysis, scribe and break only.

* 4.4.3 Group C inspection. Group C inspection shall be conducted in accordance with the conditions specified for subgroup testing in table VII of MIL-PRF-19500, and as follows. Electrical measurements (end-points) shall be in accordance with table III herein.

<u>Subgroup</u>	<u>Method</u>	<u>Condition</u>	
C2	1056	0°C to +100°C, 10 cycles.	
C2	1051	-55°C to +175°C, 20 cycles.	
C2	2036	Tension: Test condition A; weight = 4 pounds, t = 15 seconds. Lead fatigue: Test condition E. (Tension and lead fatigue are not required for UR-1 suffix devices)	
C2	1071	Test condition E.	
C3		Not applicable.	
*	C5	4081	See 4.3.2 herein.
*	C6	1027	I_{ZM} = column 8 of table IV (minimum). Adjust I_Z or T_A to achieve $T_J = 150^\circ\text{C}$ minimum (see 4.5.9).
	C7		Not applicable.
	C8	4071	I_Z = column 5 of table IV; $T_1 = +25^\circ\text{C} \pm 5^\circ\text{C}$, $T_2 = +125^\circ\text{C} \pm 5^\circ\text{C}$. (Maximum limit in accordance with column 14 of table IV). Sample size = 22, c = 0. (See 4.5.4.)

4.4.4 Group E inspection. Group E inspection shall be conducted in accordance with appendix E, table IX of MIL-PRF-19500 and table II herein.

4.5 Methods of inspection. Methods of inspection shall be as specified in the appropriate tables and as follows.

4.5.1 Surge current (I_{ZSM}). The peak currents shown in column 10 of table IV shall be applied in the reverse direction and these shall be imposed on the current ($I_Z = I_{Z1}$) (column 5 of table IV) a total of 5 surges at 1-minute intervals. Each individual surge shall be one-half square-wave-pulse of one one-hundred twenty second duration or an equivalent one-half sine wave with the same effective rms current.

4.5.2 Regulator voltage measurements. The test current shall be applied until thermal equilibrium is attained (90 seconds minimum) prior to reading the breakdown voltage. For this test, the diode shall be suspended by its leads with mounting clips whose inside edge is located at .375 inch (9.53 mm) from the body (UR version = 0 lead length) and the mounting clips shall be maintained at a temperature of +25°C +8°C, and -2°C. This measurement may be performed after a shorter time following application of the test current than that which provides thermal equilibrium if correlation to stabilized readings can be established to the satisfaction of the Government.

4.5.3 Voltage regulation V_z (reg). Voltage regulation shall be determined by the difference of the regulator voltage measured at different currents as specified in table I, subgroup 7 herein. Both tests shall be performed at thermal equilibrium. This ΔV_z shall not exceed column 9 of table IV.

4.5.4 Temperature coefficient of regulator voltage (αV_z). The device shall be temperature stabilized with current applied prior to reading regulator voltage at the specified ambient temperature as specified in 4.4.3, subgroup C8.

4.5.8 Scope display evaluation. Scope display evaluation shall be stable in accordance with method 4023 of MIL-STD-750, condition A. Scope display may be performed on ATE (automatic test equipment) for screening only with the approval of the qualifying activity. Scope display in table I, subgroup 4 shall be performed on a scope. The reverse current over the knee shall be 500 μ A peak.

* 4.5.9 Free air burn-in and life tests. Deliberate heat sinking, is prohibited unless otherwise approved by the qualifying activity. The use of a current limiting or ballast resistor is permitted provided that each DUT still sees the full P_t (minimum) and that the minimum applied voltage, where applicable, is maintained through out the burn-in period. Use method 3100 of MIL-STD-750 to measure T_j (see figure 11).

MIL-PRF-19500/117N

* TABLE I. Group A inspection.

Inspection <u>1/</u>	MIL-STD-750		Symbol	Limits <u>2/</u>		Unit
	Method	Conditions		Min	Max	
<u>Subgroup 1</u>						
Visual and mechanical examination	2071					
<u>Subgroup 2</u>						
Forward voltage	4011	$I_F = 200 \text{ mA dc.}$	V_F			V dc
1N962 – 1N985 <u>3/</u> 1N986 – 1N992 <u>3/</u>				1.1 1.3		
Reverse current	4016	DC method, $V_R =$ column 11 of table IV.	I_{R1}		Col. 12	$\mu\text{A dc}$
Regulator voltage (see 4.5.2)	4022	$I_{Z1} =$ column 5 of table IV.	V_Z	Col. 3	Col. 4	V dc
Thermal impedance	3101	See 4.3.2	$Z_{\theta JX}$			$^{\circ}\text{C/W}$
<u>Subgroup 3</u>						
High temperature operation		$T_A = 150^{\circ}\text{C}$				
Reverse current	4016	DC method, $V_R =$ column 11 of table IV.	I_{R2}		Col. 13	$\mu\text{A dc}$
<u>Subgroup 4</u>						
Small-signal reverse breakdown impedance	4051	$I_Z =$ column 5 of table IV. $I_{SIG} = 10 \text{ percent of } I_Z \text{ rms.}$	Z_Z		Col. 6	ohm
Small-signal reverse breakdown impedance	4051	$I_{ZK} = 250 \mu\text{A dc,}$ $I_{SIG} = 25 \mu\text{A rms.}$	Z_{ZK}		Col. 7	ohm
Scope display	4023	See 4.5.8, $n = 116, c = 0.$				

See footnotes at end of table.

* TABLE I. Group A inspection - Continued.

Inspection <u>1/</u>	MIL-STD-750		Symbol	Limits <u>2/</u>		Unit
	Method	Conditions		Min	Max	
<u>Subgroups 5</u> Not applicable						
<u>Subgroup 6</u> Surge	4066	See 4.5.1				
Electrical measurements		See table III, steps 1, 3 and 4.				
<u>Subgroup 7</u> Voltage regulation (see 4.5.3)		$I_Z = 10$ percent of column 8 of table IV (current 1). $I_Z = 50$ percent of column 8 of table IV (current 2).	ΔV_Z (reg)		Col. 9	V dc

1/ For sampling plan, see MIL-PRF-19500.

2/ Column references are to table IV.

3/ Applies to all suffix versions.

* TABLE II. Group E inspection qualification and requalification (all product assurance levels).

Inspection <u>1/</u>	MIL-STD-750		Qualification conformance inspection (sampling plan)
	Method	Conditions	
<u>Subgroup 1</u> Temperature cycling	1051	500 cycles.	45 devices, c = 0
Electrical measurements		See table III, steps 1, 2, 3, 4, and 5.	
<u>Subgroup 2</u> Intermittent life	1037	6,000 cycles. I_z = column 8 of table IV.	45 devices, c = 0
Electrical measurements		See table III, steps 2, 3, 4, and 5.	
<u>Subgroup 4</u> Thermal impedance, curves		Each supplier shall submit a thermal impedance ($Z_{\theta JX}$) histogram of the qual lot and thermal impedance curves of the best device and the qual lot average. A histogram of thermal resistance ($R_{\theta JX}$) shall be required (116 devices). In addition, the optimal test conditions and thermal impedance limit shall be provided to the qualifying activity in the qualification report for approval. The approved thermal impedance conditions and limit for $Z_{\theta JX}$ shall be used by the supplier in screening and for end-point measurements as applicable. The approved thermal impedance conditions for $R_{\theta JX}$ shall be used by the supplier for conformance inspection.	N/A
<u>Subgroups 5 and 6</u> Not applicable			
<u>Subgroup 9</u> Resistance to glass cracking	1057	Condition B. Cool down after solder immersion is permitted. Test until failure occurs on all devices with the chosen sample or to a maximum of 25 cycles, whichever comes first.	n = 45

1/ A separate sample may be pulled for each test.

* TABLE III. Group B, C, and E electrical and delta end-point measurements. 1/ 2/ 3/

Step	Inspection	MIL-STD-750		Symbol	Limits		Unit
		Method	Conditions		Min	Max	
1.	Reverse current	4016	DC method; V_R = column 11 of table IV.	I_{R1}		Column 12 of table IV	$\mu\text{A dc}$
2.	Reverse current	4016	DC method; V_R = column 11 of table IV.	I_{R3}		2	$\mu\text{A dc}$
3.	Regulator voltage (see 4.5.2)	4022	I_{Z1} = column 5 of table IV.	V_Z	Column 3 of table IV	Column 4 of table IV	V dc
4.	Small-signal breakdown impedance	4051	I_{Z1} = column 5 of table IV. I_{SIG} = 10 percent of I_Z rms	Z_{ZT}		Column 6 of table IV	Ohms
5.	Thermal impedance	3101	See 4.3.2	$\Delta Z_{\theta JX}$		10 percent of initial value max.	$^{\circ}\text{C/W}$

- 1/ The electrical measurements for table VIb of MIL-PRF-19500 are as follows:
- Subgroup 2, see table III herein, steps 1, 3, 4, and 5.
 - Subgroups 3 and 6, see table III herein, steps 2, 3, and 4.
- 2/ The electrical measurements for table VII of MIL-PRF-19500 are as follows:
- Subgroup 2, see table III herein, steps 1, 3, 4, and 5.
 - Subgroup 6, see table III herein, steps 2, 3, and 4.
- 3/ The electrical measurements for table IX of MIL-PRF-19500 are as follows: Subgroup 2, see table III herein, steps 2, 3, 4, and 5.

TABLE IV. Electrical characteristics (5 percent tolerance diodes).
5 percent diode types 1N962B-1 through 1N992B-1 and 1N962BUR-1 through 1N992BUR-1

Col 1	Col 2	Col 3	Col 4	Col 5	Col 6	Col 7	Col 8	Col 9	Col 10	Col 11	Col 12	Col 13	Col 14
Type	V _Z nom	V _Z min	V _Z max	I _{Z1} Test current	Z _Z Impedance	Z _{ZK} (Knee Impedance)	I _{ZM} Max dc Current	ΔV _Z Reg	I _{ZPCB} (Surge)	V _R	I _{R1} at T _A = +25°C V _R = col 11	I _{R2} at T _A = +150°C V _R = col 11	αV _Z temperature coefficient
	Volts	Volts	Volts	mA	ohms	ohms	mA	Volts	mA	Volts	μA	μA	%/°C
1N962B-1	11	10.45	11.55	11.5	9.5	700	35	0.50	590	8.4	1.0	10	+0.073
1N963B-1	12	11.40	12.60	10.5	11.5	700	32	0.55	540	9.1	1.0	10	+0.076
1N964B-1	13	12.35	13.65	9.5	13.0	700	30	0.60	500	9.9	0.5	10	+0.079
1N965B-1	15	14.25	15.75	8.5	16.0	700	26	0.70	433	11	0.5	10	+0.082
1N966B-1	16	15.20	16.80	7.8	17.0	700	25	0.75	406	12	0.5	10	+0.083
1N967B-1	18	17.10	18.90	7.0	21	750	21	0.85	361	14	0.5	10	+0.085
1N968B-1	20	19.0	21.0	6.2	25	750	19	0.95	325	15	0.5	10	+0.086
1N969B-1	22	20.9	23.1	5.6	29	750	17	1.05	295	17	0.5	10	+0.087
1N970B-1	24	22.8	25.2	5.2	33	750	16	1.15	271	18	0.5	10	+0.088
1N971B-1	27	25.7	28.3	4.6	41	750	14	1.30	240	21	0.5	10	+0.090
1N972B-1	30	28.5	31.5	4.2	49	1000	13	1.45	216	23	0.5	10	+0.091
1N973B-1	33	31.4	34.6	3.8	58	1000	12	1.60	197	25	0.5	10	+0.092
1N974B-1	36	34.2	37.8	3.4	70	1000	11	1.75	180	27	0.5	10	+0.093
1N975B-1	39	37.1	40.9	3.2	80	1000	9.1	1.90	166	30	0.5	10	+0.094
1N976B-1	43	40.9	45.1	3.0	93	1000	8.8	2.10	151	33	0.5	10	+0.095
1N977B-1	47	44.7	49.3	2.7	105	1500	7.9	2.25	138	36	0.5	10	+0.095
1N978B-1	51	48.5	53.5	2.5	125	1500	7.4	2.5	127	39	0.5	10	+0.096
1N979B-1	56	53.2	58.8	2.2	150	2000	6.9	2.7	116	43	0.5	10	+0.096
1N980B-1	62	58.9	65.1	2.0	185	2000	6.0	2.9	105	47	0.5	10	+0.097
1N981B-1	68	64.6	71.4	1.8	230	2000	5.5	3.2	95	52	0.5	10	+0.097
1N982B-1	75	71.3	78.7	1.7	270	2000	5.1	3.4	86	56	0.5	10	+0.098
1N983B-1	82	77.9	86.1	1.5	330	3000	4.6	3.8	79	62	0.5	10	+0.098
1N984B-1	91	86.5	95.5	1.4	400	3000	4.2	4.2	71	69	0.5	10	+0.099
1N985B-1	100	95.0	105.0	1.3	500	3000	3.7	4.4	65	76	0.5	10	+0.110
1N986B-1	110	104.5	115.5	1.1	750	4000	3.3	4.8	59	84	0.5	10	+0.110
1N987B-1	120	114.0	126.0	1.0	900	4500	3.1	5.2	54	91	0.5	10	+0.110
1N988B-1	130	123.5	136.5	0.95	1100	5000	2.7	5.6	50	99	0.5	10	+0.110
1N989B-1	150	142.5	157.5	0.85	1500	6000	2.4	7.0	43	114	0.5	10	+0.110
1N990B-1	160	152.0	168.0	0.80	1700	6500	2.2	7.5	40	122	0.5	10	+0.110
1N991B-1	180	171.0	189.0	0.68	2200	7100	2.0	9.0	36	137	0.5	10	+0.110
1N992B-1	200	190.0	210.0	0.65	2500	8000	1.8	12.0	32	152	0.5	10	+0.110

TABLE IV. Electrical characteristics (2 percent tolerance diodes) – Continued.
 2 percent diode types 1N962C-1 through 1N992C-1 and 1N962CUR-1 through 1N992CUR-1

Col 1	Col 2	Col 3	Col 4	Col 5	Col 6	Col 7	Col 8	Col 9	Col 10	Col 11	Col 12	Col 13	Col 14
Type	V _Z nom	V _Z min	V _Z max	I _{Z1} Test current	Z _Z Impedance	Z _{ZK} (Knee Impedance)	I _{ZM} Max dc Current	ΔV _Z Reg	I _{ZPCB} (Surge)	V _R	I _{R1} at T _A = +25°C V _R = col 11	I _{R2} at T _A = +150°C V _R = col 11	αV _Z temperature coefficient
	Volts	Volts	Volts	mA	ohms	ohms	mA	Volts	mA	Volts	μA	μA	%/°C
1N962C-1	11	10.78	11.22	11.5	9.5	700	35	0.50	590	8.4	1.0	10	+0.073
1N963C-1	12	11.76	12.24	10.5	11.5	700	32	0.55	540	9.1	1.0	10	+0.076
1N964C-1	13	12.74	13.25	9.5	13.0	700	30	0.60	500	9.9	0.5	10	+0.079
1N965C-1	15	14.70	15.30	8.5	16.0	700	26	0.70	433	11	0.5	10	+0.082
1N966C-1	16	15.68	16.32	7.8	17.0	700	25	0.75	406	12	0.5	10	+0.083
1N967C-1	18	17.64	18.36	7.0	21	750	21	0.85	361	14	0.5	10	+0.085
1N968C-1	20	19.60	20.40	6.2	25	750	19	0.95	325	15	0.5	10	+0.086
1N969C-1	22	21.56	22.44	5.6	29	750	17	1.05	295	17	0.5	10	+0.087
1N970C-1	24	23.52	24.48	5.2	33	750	16	1.15	271	18	0.5	10	+0.088
1N971C-1	27	26.46	27.54	4.6	41	750	14	1.30	240	21	0.5	10	+0.090
1N972C-1	30	29.40	30.60	4.2	49	1000	13	1.45	216	23	0.5	10	+0.091
1N973C-1	33	32.34	33.66	3.8	58	1000	12	1.60	197	25	0.5	10	+0.092
1N974C-1	36	35.28	36.72	3.4	70	1000	11	1.75	180	27	0.5	10	+0.093
1N975C-1	39	38.22	39.78	3.2	80	1000	9.1	1.90	166	30	0.5	10	+0.094
1N976C-1	43	42.14	43.86	3.0	93	1000	8.8	2.10	151	33	0.5	10	+0.095
1N977C-1	47	46.06	47.94	2.7	105	1500	7.9	2.25	138	36	0.5	10	+0.095
1N978C-1	51	49.98	52.02	2.5	125	1500	7.4	2.5	127	39	0.5	10	+0.096
1N979C-1	56	54.88	57.12	2.2	150	2000	6.9	2.7	116	43	0.5	10	+0.096
1N980C-1	62	60.76	63.24	2.0	185	2000	6.0	2.9	105	47	0.5	10	+0.097
1N981C-1	68	66.64	69.36	1.8	230	2000	5.5	3.2	95	52	0.5	10	+0.097
1N982C-1	75	73.50	76.50	1.7	270	2000	5.1	3.4	86	56	0.5	10	+0.098
1N983C-1	82	80.36	83.64	1.5	330	3000	4.6	3.8	79	62	0.5	10	+0.098
1N984C-1	91	89.18	92.82	1.4	400	3000	4.2	4.2	71	69	0.5	10	+0.099
1N985C-1	100	98.0	102.0	1.3	500	3000	3.7	4.4	65	76	0.5	10	+0.110
1N986C-1	110	107.8	112.2	1.1	750	4000	3.3	4.8	59	84	0.5	10	+0.110
1N987C-1	120	117.6	122.4	1.0	900	4500	3.1	5.2	54	91	0.5	10	+0.110
1N988C-1	130	127.4	132.6	0.95	1100	5000	2.7	5.6	50	99	0.5	10	+0.110
1N989C-1	150	147.0	153.0	0.85	1500	6000	2.4	7.0	43	114	0.5	10	+0.110
1N990C-1	160	156.8	163.2	0.80	1700	6500	2.2	7.5	40	122	0.5	10	+0.110
1N991C-1	180	176.4	183.6	0.68	2200	7100	2.0	9.0	36	137	0.5	10	+0.110
1N992C-1	200	196.0	204.0	0.65	2500	8000	1.8	12.0	32	152	0.5	10	+0.110

TABLE IV. Electrical characteristics (1 percent tolerance diodes) – Continued.
1 percent diode types 1N962D-1 through 1N992DUR-1

Col 1 Type	Col 2	Col 3	Col 4	Col 5	Col 6	Col 7	Col 8	Col 9	Col 10	Col 11	Col 12	Col 13	Col 14
	V _Z nom	V _Z min	V _Z max	I _{Z1} Test current	Z _Z Impedance	Z _{ZK} (Knee Impedance)	I _{ZM} Max dc Curr-	ΔV _Z Reg	I _{ZPCB} (Surge)	V _R	I _{R1} at T _A = +25°C V _R = col 11	I _{R2} at T _A = +150°C V _R =	αV _Z temperature coefficient
	Volts	Volts	Volts	mA	ohms	ohms	mA	Volts	mA	Volts	μA	μA	%/°C
1N962D-1	11	10.89	11.11	11.5	9.5	700	35	0.50	590	8.4	1.0	10	+0.073
1N963D-1	12	11.88	12.12	10.5	11.5	700	32	0.55	540	9.1	1.0	10	+0.076
1N964D-1	13	12.87	13.13	9.5	13.0	700	30	0.60	500	9.9	0.5	10	+0.079
1N965D-1	15	14.85	15.15	8.5	16.0	700	26	0.70	433	11	0.5	10	+0.082
1N966D-1	16	15.84	16.16	7.8	17.0	700	25	0.75	406	12	0.5	10	+0.083
1N967D-1	18	17.82	18.18	7.0	21	750	21	0.85	361	14	0.5	10	+0.085
1N968D-1	20	19.80	20.20	6.2	25	750	19	0.95	325	15	0.5	10	+0.086
1N969D-1	22	21.78	22.22	5.6	29	750	17	1.05	295	17	0.5	10	+0.087
1N970D-1	24	23.76	24.24	5.2	33	750	16	1.15	271	18	0.5	10	+0.088
1N971D-1	27	26.73	27.27	4.6	41	750	14	1.30	240	21	0.5	10	+0.090
1N972D-1	30	29.70	30.30	4.2	49	1000	13	1.45	216	23	0.5	10	+0.091
1N973D-1	33	32.67	33.33	3.8	58	1000	12	1.60	197	25	0.5	10	+0.092
1N974D-1	36	35.64	36.36	3.4	70	1000	11	1.75	180	27	0.5	10	+0.093
1N975D-1	39	38.61	39.39	3.2	80	1000	9.1	1.90	166	30	0.5	10	+0.094
1N976D-1	43	42.57	43.43	3.0	93	1000	8.8	2.10	151	33	0.5	10	+0.095
1N977D-1	47	46.53	47.47	2.7	105	1500	7.9	2.25	138	36	0.5	10	+0.095
1N978D-1	51	50.49	51.51	2.5	125	1500	7.4	2.5	127	39	0.5	10	+0.096
1N979D-1	56	55.44	56.56	2.2	150	2000	6.9	2.7	116	43	0.5	10	+0.096
1N980D-1	62	61.38	62.62	2.0	185	2000	6.0	2.9	105	47	0.5	10	+0.097
1N981D-1	68	67.32	68.68	1.8	230	2000	5.5	3.2	95	52	0.5	10	+0.097
1N982D-1	75	74.25	75.75	1.7	270	2000	5.1	3.4	86	56	0.5	10	+0.098
1N983D-1	82	81.18	82.82	1.5	330	3000	4.6	3.8	79	62	0.5	10	+0.098
1N984D-1	91	90.09	91.91	1.4	400	3000	4.2	4.2	71	69	0.5	10	+0.099
1N985D-1	100	99.0	101.0	1.3	500	3000	3.7	4.4	65	76	0.5	10	+0.110
1N986D-1	110	108.9	111.1	1.1	750	4000	3.3	4.8	59	84	0.5	10	+0.110
1N987D-1	120	118.8	121.2	1.0	900	4500	3.1	5.2	54	91	0.5	10	+0.110
1N988D-1	130	128.7	131.3	0.95	1100	5000	2.7	5.6	50	99	0.5	10	+0.110
1N989D-1	150	148.5	151.5	0.85	1500	6000	2.4	7.0	43	114	0.5	10	+0.110
1N990D-1	160	158.4	161.6	0.80	1700	6500	2.2	7.5	40	122	0.5	10	+0.110
1N991D-1	180	178.2	181.8	0.68	2200	7100	2.0	9.0	36	137	0.5	10	+0.110
1N992D-1	200	198.0	202.0	0.65	2500	8000	1.8	12.0	32	152	0.5	10	+0.110

Temperature-Power Derating Curve

D0-7, D0-35

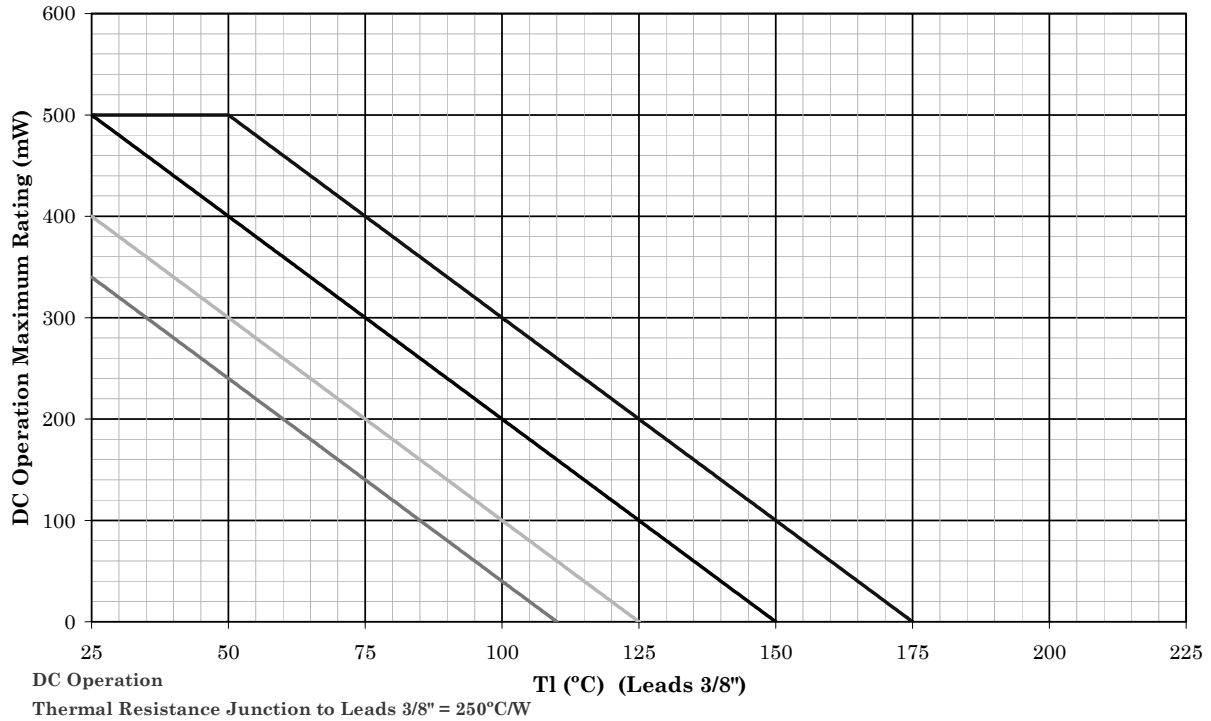

NOTES:

1. All devices are capable of operating at $\leq T_J$ specified on this curve. Any parallel line to this curve will intersect the appropriate power for the desired maximum T_J allowed.
2. Derate design curve constrained by the maximum junction temperature ($T_J \leq 175^\circ\text{C}$) and power rating specified. (See 1.3 herein.)
3. Derate design curve chosen at $T_J \leq 150^\circ\text{C}$, where the maximum temperature of electrical test is performed.
4. Derate design curves chosen at $T_J \leq 125^\circ\text{C}$, and 110°C to show power rating where most users want to limit T_J in their application.

* FIGURE 4. Temperature-power derating curve.

Temperature-Power Derating Curve

D0-213AA

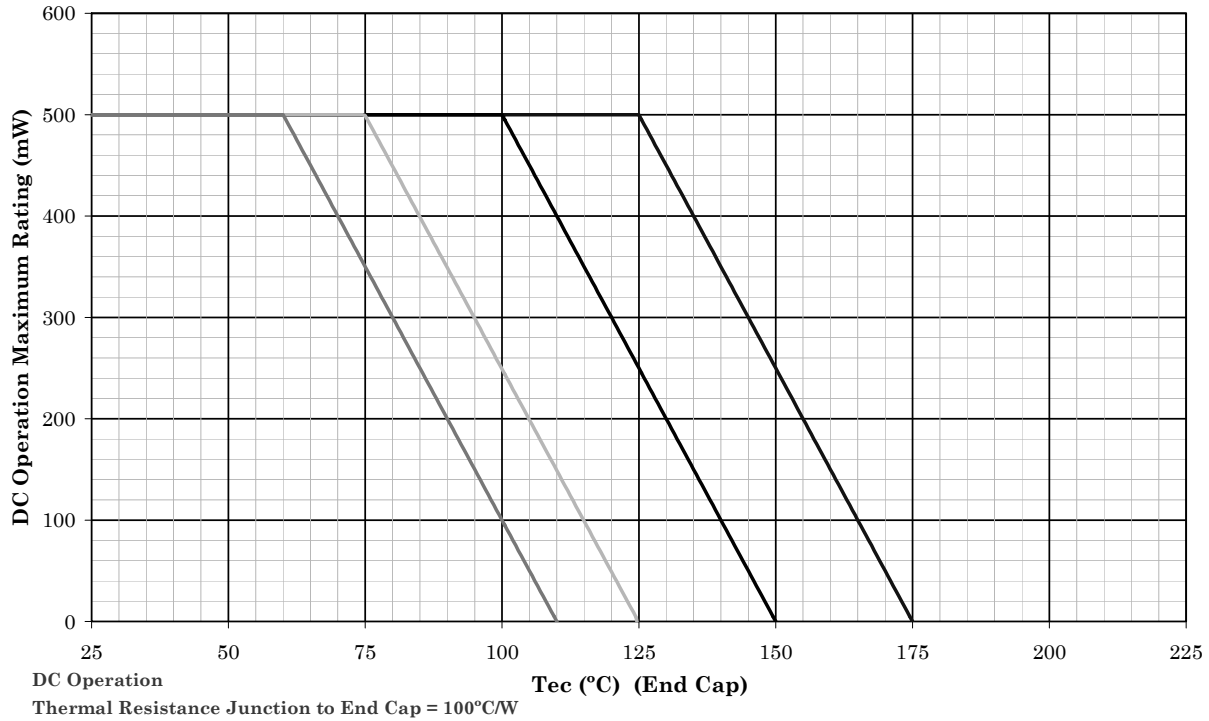

NOTES:

1. All devices are capable of operating at $\leq T_J$ specified on this curve. Any parallel line to this curve will intersect the appropriate power for the desired maximum T_J allowed.
2. Derate design curve constrained by the maximum junction temperature ($T_J \leq 175^\circ\text{C}$) and power rating specified. (See 1.3 herein.)
3. Derate design curve chosen at $T_J \leq 150^\circ\text{C}$, where the maximum temperature of electrical test is performed.
4. Derate design curves chosen at $T_J \leq 125^\circ\text{C}$, and 110°C to show power rating where most users want to limit T_J in their application.

* FIGURE 5. Temperature-power derating curve.

Temperature-Power Derating Curve

D0-7, D0-35

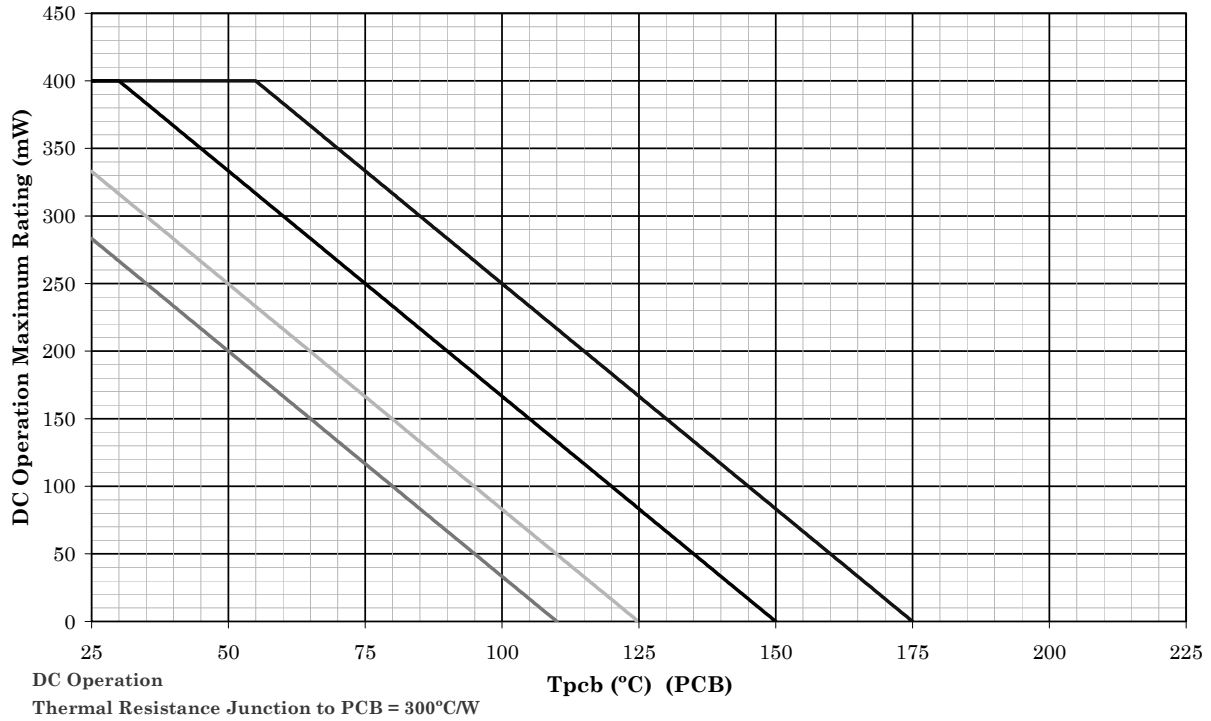

NOTES:

1. All devices are capable of operating at $\leq T_J$ specified on this curve. Any parallel line to this curve will intersect the appropriate power for the desired maximum T_J allowed.
2. Derate design curve constrained by the maximum junction temperature ($T_J \leq 175^\circ\text{C}$) and power rating specified. (See 1.3 herein.)
3. Derate design curve chosen at $T_J \leq 150^\circ\text{C}$, where the maximum temperature of electrical test is performed.
4. Derate design curves chosen at $T_J \leq, 125^\circ\text{C}$, and 110°C to show power rating where most users want to limit T_J in their application.

* FIGURE 6. Temperature-power derating curve.

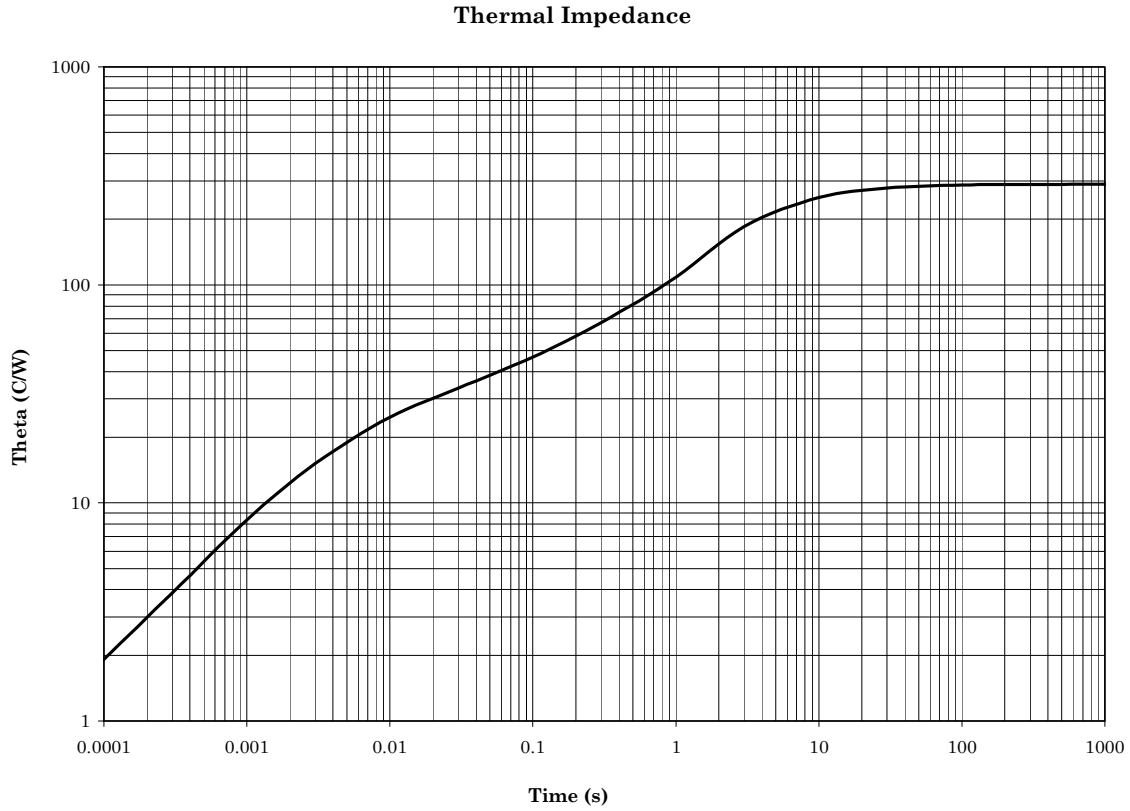

Thermal impedance DO-35 PCB mount, FR4, 1oz Cu, 50x87 mil pad (MELF) and 92 mil diameter (axial with .125 inch (3.175 mm) lead length) at $T_A = 25^\circ\text{C}$.

NOTE: Thermal resistance = 300°C/W . Maximum power rating = 400 mW at $T_A = 55^\circ\text{C}$.

* FIGURE 7. Thermal impedance DO-35 PCB mount.

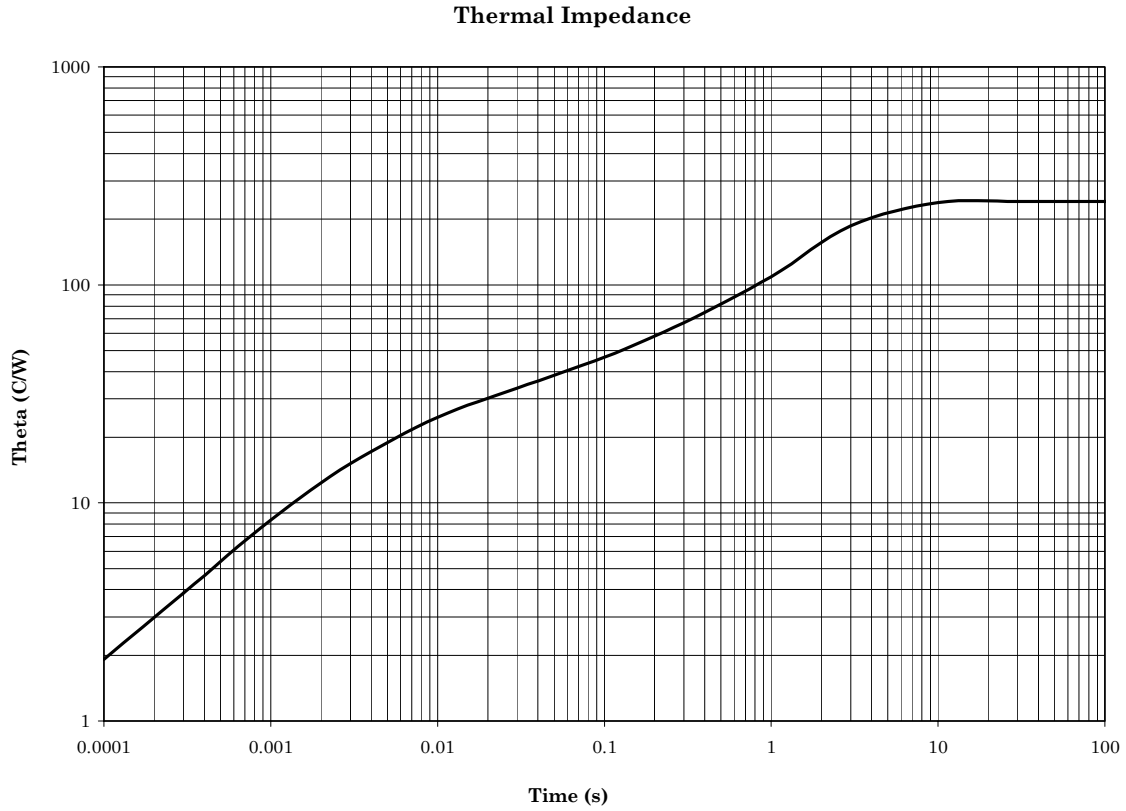

Thermal impedance DO-35 axial, $T_J = 25^\circ\text{C}$ at .375 inch (9.52 mm) from body.
NOTE: Thermal resistance = 250°C/W . Maximum power rating = 500 mW at $T_J = 50^\circ\text{C}$.

* FIGURE 8. Thermal impedance DO-35 Axial.

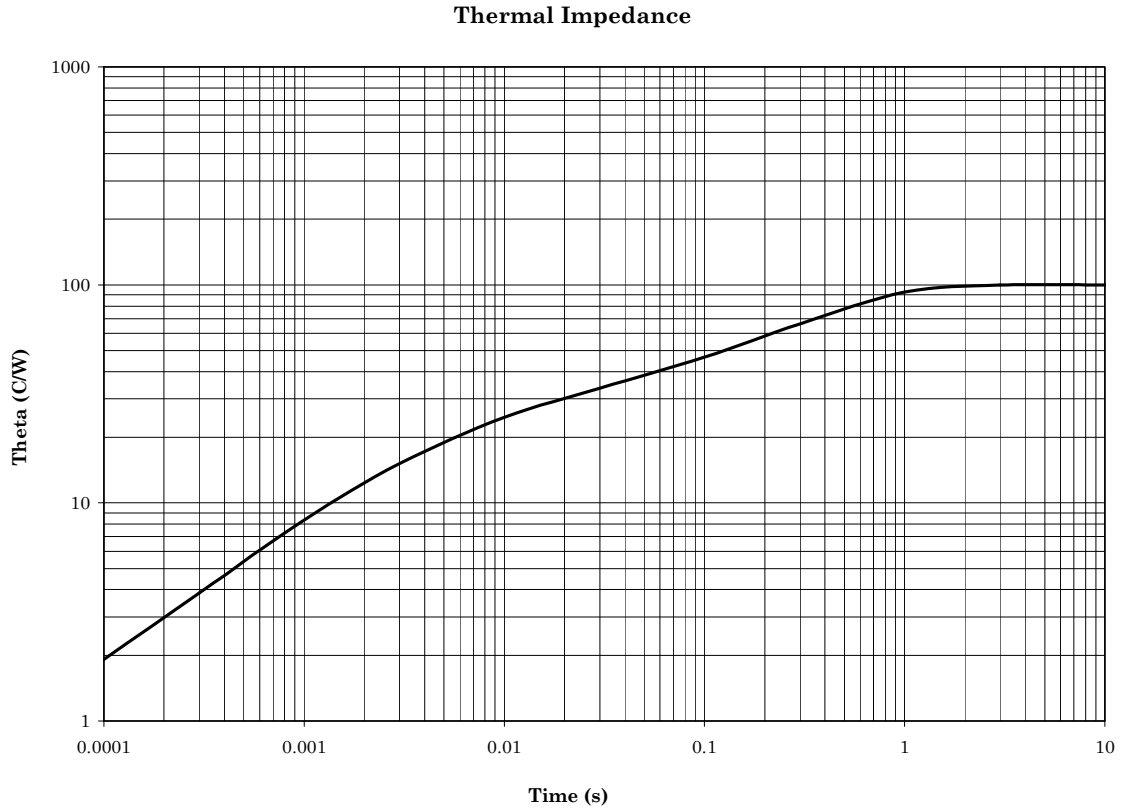

Thermal impedance DO-35 MELF, $T_{ec}=25^{\circ}\text{C}$.
NOTE: Thermal resistance = 100°C/W . Power rating = 500 mW at $T_{ec}=125^{\circ}\text{C}$.

* FIGURE 9. Thermal impedance DO-213 MELF.

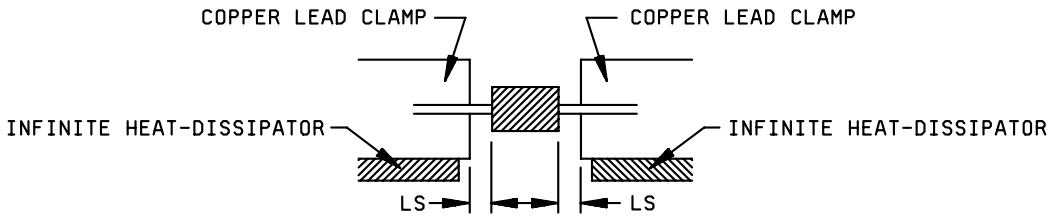
FIGURE 10. Mounting conditions.

5. PACKAGING

5.1 Packaging. For acquisition purposes, the packaging requirements shall be as specified in the contract or order (see 6.2). When packaging of materiel is to be performed by DoD or in-house contractor personnel, these personnel need to contact the responsible packaging activity to ascertain packaging requirements. Packaging requirements are maintained by the Inventory Control Point's packaging activities within the Military Service or Defense Agency, or within the Military Service's system commands. Packaging data retrieval is available from the managing Military Department's or Defense Agency's automated packaging files, CD-ROM products, or by contacting the responsible packaging activity.

6. NOTES

(This section contains information of a general or explanatory nature that may be helpful, but is not mandatory.)

6.1 Intended use. The notes specified in MIL-PRF-19500 are applicable to this specification.

6.2 Acquisition requirements. Acquisition documents should specify the following:

- a. Title, number, and date of this specification.
- b. Packaging requirements (see 5.1).
- c. Lead finish (see 3.4.1).
- d. Product assurance level and type designator.

* 6.3 Qualification. With respect to products requiring qualification, awards will be made only for products which are, at the time of award of contract, qualified for inclusion in Qualified Manufacturers List (QML 19500) whether or not such products have actually been so listed by that date. The attention of the contractors is called to these requirements, and manufacturers are urged to arrange to have the products that they propose to offer to the Federal Government tested for qualification in order that they may be eligible to be awarded contracts or orders for the products covered by this specification. Information pertaining to qualification of products may be obtained from Defense Supply Center, Columbus, ATTN: DSCC/VQE, P.O. Box 3990, Columbus, OH 43218-3990 or e-mail vqe.chief@dla.mil.

MIL-PRF-19500/117N

6.4 Cross reference substitution list. JANS level will no longer be built to MIL-PRF-19500/117. Devices in stock are acceptable provided the date code does not exceed the date of 8 September 1997. Devices required for space flight applications shall meet the requirements of MIL-PRF-19500/533. Existing supplies of parts can be used until existing supplies are exhausted. A PIN for PIN replacement table follows, and these devices are directly interchangeable:

JANS superseded PIN	JANS superseding PIN	JANS superseded PIN	JANS superseding PIN
1N6327	1N964B-1	1N6342	1N979B-1
1N6328	1N965B-1	1N6343	1N980B-1
1N6329	1N966B-1	1N6344	1N981B-1
1N6330	1N967B-1	1N6345	1N982B-1
1N6331	1N968B-1	1N6346	1N983B-1
1N6332	1N969B-1	1N6347	1N984B-1
1N6333	1N970B-1	1N6348	1N985B-1
1N6334	1N971B-1	1N6349	1N986B-1
1N6335	1N972B-1	1N6350	1N987B-1
1N6336	1N973B-1	1N6351	1N988B-1
1N6337	1N974B-1	1N6352	1N989B-1
1N6338	1N975B-1	1N6353	1N990B-1
1N6339	1N976B-1	1N6354	1N991B-1
1N6340	1N977B-1	1N6355	1N992B-1
1N6341	1N978B-1		

6.5 Suppliers of JANHC and JANKC die. The qualified JANHC and JANKC die suppliers with the applicable letter version (example JANHCA1N4370A) will be identified on the QML.

JANHC ordering information (1)		
PIN	Manufacture CAGE	
	43611	12954
1N964B	JANHCA1N964B	JANHCB1N964B
1N965B	JANHCA1N965B	JANHCB1N965B
1N966B	JANHCA1N966B	JANHCB1N966B
1N967B	JANHCA1N967B	JANHCB1N967B
1N968B	JANHCA1N968B	JANHCB1N968B
1N969B	JANHCA1N969B	JANHCB1N969B
1N970B	JANHCA1N970B	JANHCB1N970B
1N971B	JANHCA1N971B	JANHCB1N971B
1N972B	JANHCA1N972B	JANHCB1N972B
1N973B	JANHCA1N973B	JANHCB1N973B
1N974B	JANHCA1N974B	JANHCB1N974B
1N975B	JANHCA1N975B	JANHCB1N975B
1N976B	JANHCA1N976B	JANHCB1N976B
1N977B	JANHCA1N977B	JANHCB1N977B
1N978B	JANHCA1N978B	JANHCB1N978B
1N979B	JANHCA1N979B	JANHCB1N979B
1N980B	JANHCA1N980B	JANHCB1N980B
1N981B	JANHCA1N981B	JANHCB1N981B
1N982B	JANHCA1N982B	JANHCB1N982B
1N983B	JANHCA1N983B	JANHCB1N983B
1N984B	JANHCA1N984B	JANHCB1N984B
1N985B	JANHCA1N985B	JANHCB1N985B
1N986B	JANHCA1N986B	JANHCB1N986B
1N987B	JANHCA1N987B	JANHCB1N987B
1N988B	JANHCA1N988B	JANHCB1N988B
1N989B	JANHCA1N989B	JANHCB1N989B
1N990B	JANHCA1N990B	JANHCB1N990B
1N991B	JANHCA1N991B	JANHCB1N991B
1N992B	JANHCA1N992B	JANHCB1N992B

(1) Applies to "C" and "D" suffix versions also. Simply replace all "B" suffixes with "C" or "D" as applicable for correct PIN.

6.6 Maximum power versus lead temperature. Typical maximum power rating as a function of lead temperature for various lead lengths is shown on figure 11.

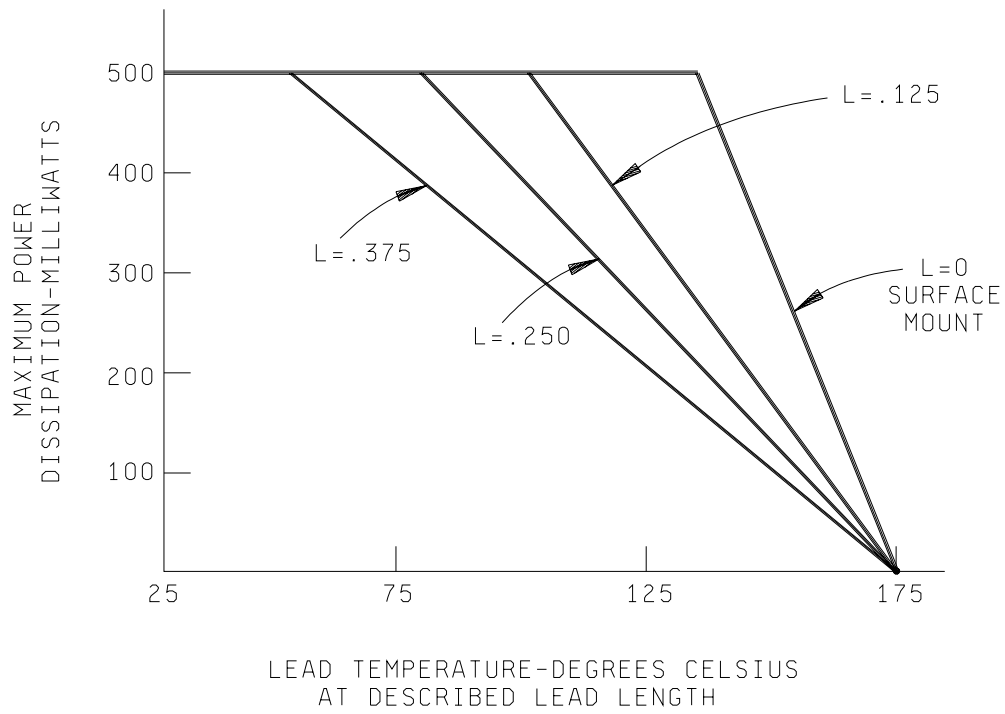

Inches	Millimeters
.000	0.00
.125	3.18
.250	6.35
.375	9.53

FIGURE 11. Maximum power versus lead temperature and lead length.

6.7 Changes from previous issue. The margins of this specification are marked with asterisks to indicate where changes from the previous issue were made. This was done as a convenience only and the Government assumes no liability whatsoever for any inaccuracies in these notations. Bidders and contractors are cautioned to evaluate the requirements of this document based on the entire content irrespective of the marginal notations and relationship to the last previous issue.

Custodians:

Army - CR
Navy - EC
Air Force - 11
NASA - NA
DLA - CC

Preparing activity:

DLA - CC

Review activities:

Army – AR, AV, MI, SM
Navy – AS, MC
Air Force – 19, 99

(Project 5961-2974)

* NOTE: The activities listed above were interested in this document as of the date of this document. Since organizations and responsibilities can change, you should verify the currency of the information above using the ASSIST Online database at <http://assist.daps.dla.mil>.