

PRODUCT PROFILE

CURRENT TRANSFORMER

MODEL 1411-180

Application

Relaying and metering.

Frequency

50-400 Hz.

Insulation Level

0.6kV, 10 kV BIL full wave.

- Terminals are brass studs No. 8-32 UNC with one flatwasher, lockwasher and regular nut.
- Flexible leads are UL 1015 105 °C. CSA approved, #16 AWG, 24" long.
- Approximate weight 3.5 lbs.

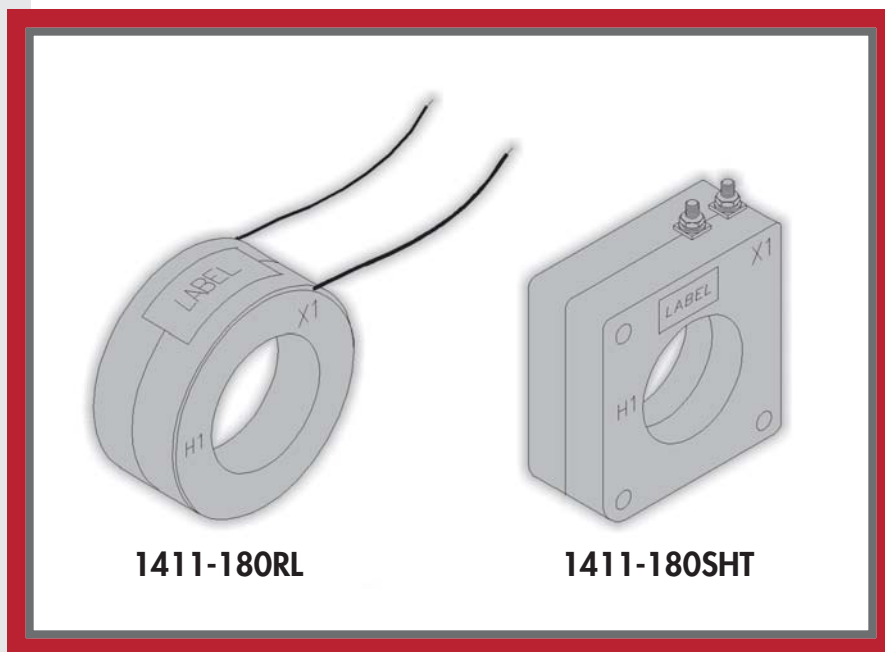

1411-180RL

1411-180SHT

WINDOW DIAMETER 2.50"

REGULATORY AGENCY APPROVALS



Manufactured to meet the requirements of ANSI/IEEE C57.13.

Classified by U.L. in accordance with IEC 44-1

Approved for revenue metering by Industry Canada. No. T-189(*)

SPECIFICATIONS

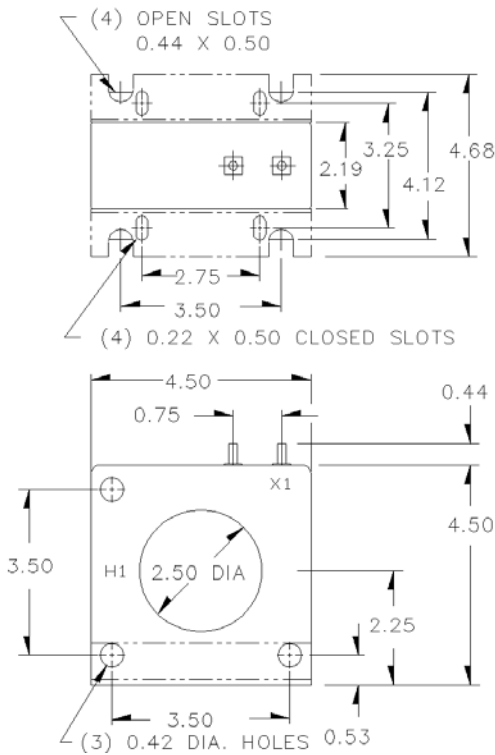

1411-180SHT

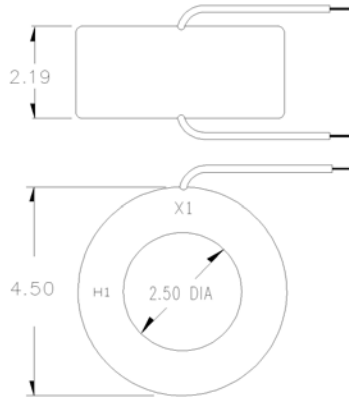

1411-180RL

CATALOG NUMBER	CURRENT RATIO	V.A. FOR ±1% CLASS	ANSI METERING CLASS AT 60 Hz					SECONDARY WINDING RESISTANCE (OHMS @ 75°C)	CONTINUOUS THERMAL RATING FACTOR	
			B0.1	B0.2	B0.5	B0.9	B1.8		@30°C	@55°C
1411-180**-500	50:5	1.5	2.4	-	-	-	-	0.009	1.33	1.0
1411-180**-750	75:5	2.5	1.2	2.4	-	-	-	0.018	1.33	1.0
1411-180**-101	100:5	2.5	1.2	2.4	4.8	-	-	0.021	1.33	1.0
1411-180**-151	150:5*	5.0	0.6	1.2	2.4	4.8	-	0.038	1.33	1.0
1411-180**-201	200:5*	12.5	0.6	0.6	1.2	2.4	-	0.051	1.33	1.0
1411-180**-251	250:5*	12.5	0.3	0.3	0.6	1.2	-	0.064	1.33	1.0
1411-180**-301	300:5*	25.0	0.3	0.3	0.6	1.2	2.4	0.076	1.33	1.0
1411-180**-401	400:5*	50.0	0.3	0.3	0.3	0.6	1.2	0.102	1.33	1.0
1411-180**-501	500:5*	50.0	0.3	0.3	0.3	0.6	1.2	0.148	1.33	1.0
1411-180**-601	600:5*	50.0	0.3	0.3	0.3	0.6	1.2	0.177	1.33	1.0
1411-180**-751	750:5*	50.0	0.3	0.3	0.3	0.6	1.2	0.174	1.33	1.0
1411-180**-801	800:5*	75.0	0.3	0.3	0.3	0.6	1.2	0.202	1.33	1.0
1411-180**-102	1000:5*	100.0	0.3	0.3	0.3	0.3	0.6	0.253	1.33	1.0
1411-180**-122	1200:5*	125.0	0.3	0.3	0.3	0.3	0.3	0.303	1.33	1.0
1411-180**-152	1500:5*	160.0	0.3	0.3	0.3	0.3	0.3	0.307	1.33	1.0
1411-180**-162	1600:5*	175.0	0.3	0.3	0.3	0.3	0.3	0.359	1.25	1.0
1411-180**-202	2000:5*	200.0	0.3	0.3	0.3	0.3	0.3	0.449	1.0	0.75

** NOTE: When ordering, prefix catalog number with model designation required, i.e.1411-180RL-301, 1411-180SHT-301, etc.

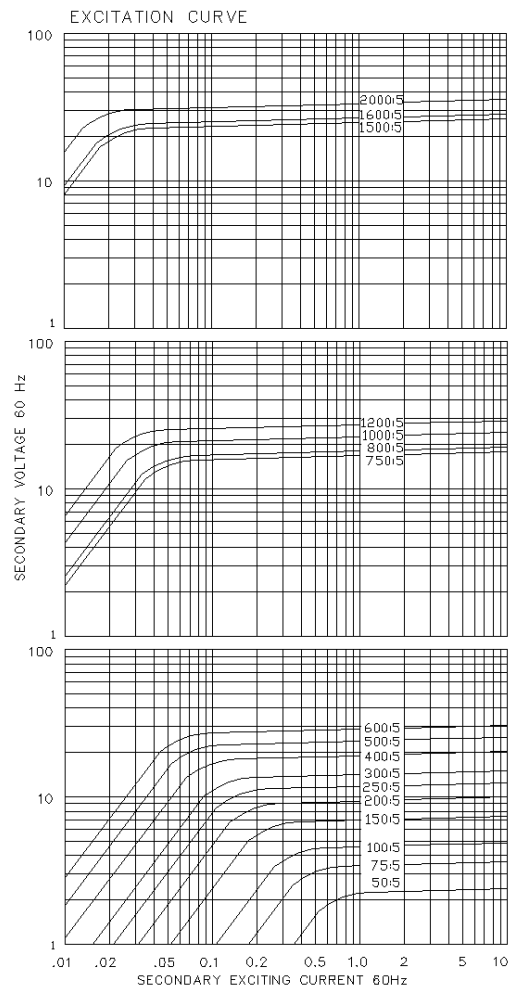

www.rockwellautomation.com

Power, Control and Information Solutions Headquarters

Americas: Rockwell Automation, 1201 South Second Street, Milwaukee, WI 53204-2496 USA, Tel: (1) 414.382.2000, Fax: (1) 414.382.4444

Europe/Middle East/Africa: Rockwell Automation, Vorstlaan/Boulevard du Souverain 36, 1170 Brussels, Belgium, Tel: (32) 2 663 0600, Fax: (32) 2 663 0640

Asia Pacific: Rockwell Automation, Level 14, Core F, Cyberport 3, 100 Cyberport Road, Hong Kong, Tel: (852) 2887 4788, Fax: (852) 2508 1846