

ELPAQ

ELPAQ

EMS256K8A

A division of ELMO Semiconductor Corp.

20 - 35ns

2Mb CMOS STATIC SRAM

FEATURES

- High density SRAM module
- Organized as 262,144 x 8
- Access time 20 - 35ns
- Low power consumption
Standby: 40mW(typ.)
Operating: 1100mW(typ.)
- Power supply voltage $5V \pm 10\%$
- TTL compatible inputs and outputs
- Fully static operation
- 32 pin DIP package
- JEDEC standard pinout
- MIL or commercial temperature range

Pin Configuration

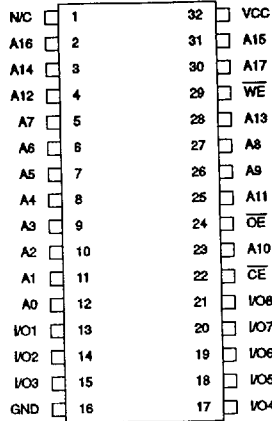

Pin Description

A0 - A17	Address Inputs
I/O1 - I/O8	Data Inputs/Outputs
\overline{CE}	Chip Enable
\overline{OE}	Output Enable
\overline{WE}	Write Enable
VCC	Power Supply
GND	Ground

GENERAL DESCRIPTION

The ELPAQ EMS256Kx8A is a high performance 2Mb CMOS SRAM module organized as 262,144 bytes of 8 bits each, using two 1Mb SRAMs. The EMS256Kx8A is packaged in a 32 lead 600 mil wide ceramic or plastic DIP package. The module is offered in a variety of temperature and speed combinations.

All inputs and outputs are TTL compatible and the module operates from a single 5V power supply. The EMS256Kx8A is a fully asynchronous SRAM and requires no clocks for operation. The module is also available in Low Power and Low Power with Data Retention versions for applications where low current and low stand-by voltages are required.

Writing data to the module is accomplished by bringing the chip enable (\overline{CE}) and write enable (\overline{WE}) inputs LOW. Data present on the eight I/O pins ($I/O_1 - I/O_8$) of the device is then written into the memory location specified by the address inputs ($A_0 - A_{17}$). Reading data from the device is accomplished by bringing chip enable (\overline{CE}) and (\overline{OE}) LOW while write enable remains inactive or HIGH. The data in the location specified by the address inputs will appear on the I/O pins.

ELPAQ

ELPAQ

T-46-23-N

EMS256K8A

A division of ELMO Semiconductor Corp.

20 - 35ns

BLOCK DIAGRAM

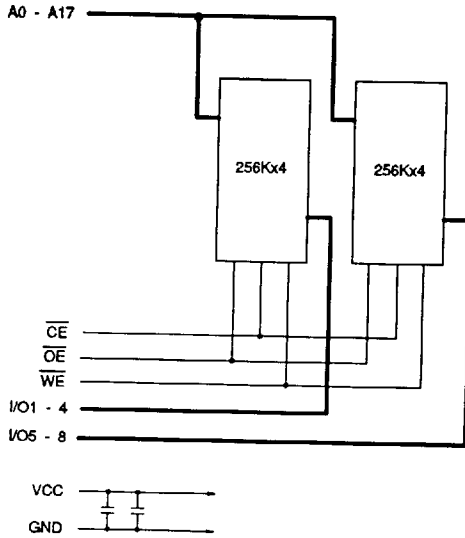

PACKAGE OUTLINE

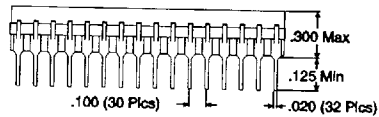
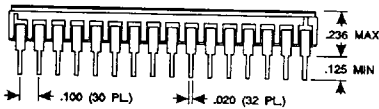
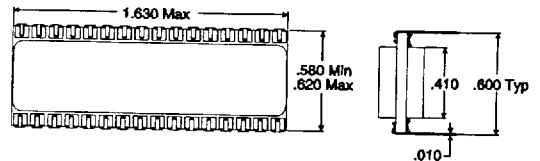
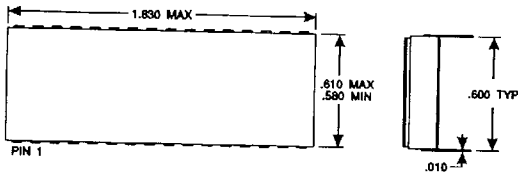

Package Type MO2, 32 Lead .600" Sidebrazed DIP

Package Type MO6, 32 Lead .600" Plastic DIP

ELPAQ

ELPAQ

T-46-23-14

EMS256K8A**20 - 35ns***A division of ELMO Semiconductor Corp.***ABSOLUTE MAXIMUM RATINGS****OPERATING RANGES****Storage Temperature**

Ceramic Packages	-65°C to +150°C
Plastic Packages	-55°C to +125°C

Operating Temperature

Commercial	0°C to +70°C
Industrial	-40°C to +85°C
Military	-55°C to +125°C

Voltage and Current

Supply Voltage	-0.5 to +7.0V
Input Voltage	-0.5 to Vcc+0.5V
Input/Output Voltage	-0.5 to Vcc+0.5V
Allowable Power Dissipation	1.9W

Voltage and Current

Supply Voltage	4.5 to 5.5V
Input High Voltage	2.2 to Vcc+0.3V
Input Low Voltage	-0.5 to 0.8V

Soldering Temperature*Time 260°C * 10s

FUNCTIONAL TRUTH TABLE

\overline{CE}	\overline{OE}	\overline{WE}	Mode	I/O 1 - 8	Vcc Current
H	X	X	Not Selected	High Z	ISB1, ISB2
L	H	H	Output Disable	High Z	ICC
L	L	H	Read	Data Out	ICC
L	X	L	Write	Data In	ICC

CAPACITANCE (Ta=25°C, f=1MHz)

Item	Symbol	Test Conditions	Min.	Typ.	Max.	Unit
Input Capacitance	C _{IN}	V _{IN} = 0V		15	25	pF
Input/Output Capacitance	C _{I/O}	V _{I/O} = 0V		20	25	pF

Note: This parameter is sample tested and not 100% tested.

ELPAQ

ELPAQ

7-23-14

EMS256K8A

A division of ELMO Semiconductor Corp.

20 - 35ns**DC CHARACTERISTICS (Vcc=5V±10%, Ta=Topr)**

Item	Symbol	Test Condition	Min.	Typ.	Max.	Unit
Input Leakage Current	IIL	VIN=GND or VCC	-10		10	μA
Output Leakage Current	IOL	V _{I/O} =GND or VCC, \overline{CE} =VIH OE=VIH or \overline{WE} =VIL	-10		10	μA
Average Operating Current	ICC	Min. Cycle, Iout=0mA		220	340	mA
Standby Current	ISB1	\overline{CE} ≥VCC-0.2V, VIN≥VCC-0.2V		8	30	mA
	ISB2	\overline{CE} =VIH, VIN=VIL or VIH		14	40	mA
Output High Voltage	VOH	IOH=-4.0mA	2.4			V
Output Low Voltage	VOL	IOL=8.0mA			0.4	V
Data Retention Current	ICCDR	VCC=3.0V		300	500	μA

AC CHARACTERISTICS (Vcc=5V±10%, Ta=Topr)**AC Test Conditions**

Item	Condition
Input Pulse High Level	VIH=3V
Input Pulse Low Level	VIL=0V
Input Pulse Rise Time	tr=2ns
Input Pulse Fall Time	tf=2ns
Input and Output Timing Level	1.5V
Output Load	Fig. 1

Output Load

Fig. 1

ELPAQ

ELPAQ T-46-23-14

EMS256K8A

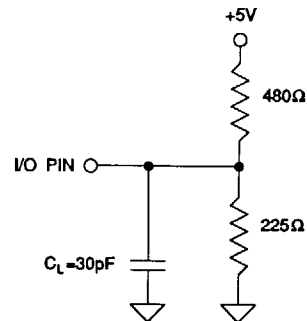
A division of ELMO Semiconductor Corp.

20 - 35ns**Read Cycle**

Item	Symbol	-20		-25		-35		Unit
		Min.	Max.	Min.	Max.	Min.	Max.	
Read Cycle Time	TAVAV	20		25		35		ns
Address Access Time	TAVQV		20		25		35	ns
Chip Enable Access Time	TELQV		20		25		35	ns
Output Enable to Output Valid	TGLQV		10		12		15	ns
Chip Enable to Output in High Z	TEHQZ		9		10		12	ns
Chip Enable to Output in Low Z	TELQX	5		5		5		ns
Output Disable to Output in High Z	TGHQZ		9		10		12	ns
Output Enable to Output in Low Z	TGLQX	0		0		0		ns
Output Hold from Address Change	TAVQX	5		5		5		ns

Write Cycle

Item	Symbol	-20		-25		-35		Unit
		Min.	Max.	Min.	Max.	Min.	Max.	
Write Cycle Time	TAVAV	20		25		35		ns
Address Valid to End of Write	TAVWH	15		17		20		ns
Chip Enable to End of Write	TELWH	15		17		20		ns
	TWLEH	15		17		20		ns
Data to Write Time Overlap	TDVWH	10		10		15		ns
	TDVEH	10		10		15		ns
Data Hold Time from Write	TWHDX	0		0		0		ns
	TEHDX	0		0		0		ns
Write Pulse Width	TWLWH	15		17		20		ns
	TELEH	15		17		20		ns
Address Set-up Time	TAVWL	0		0		0		ns
	TAVEL	0		0		0		ns
Write Recovery Time	TWHAX	0		0		0		ns
	TEHAX	0		0		0		ns
Write to Output in High Z	TWLQZ		9		10		15	ns
Output Active from End of Write	TWHQX	5		5		5		ns

Timing Diagrams

Read Cycle Timing

Read Cycle 1: $\overline{CE}=\overline{OE}=\text{VIL}, \overline{WE}=\text{VIH}$

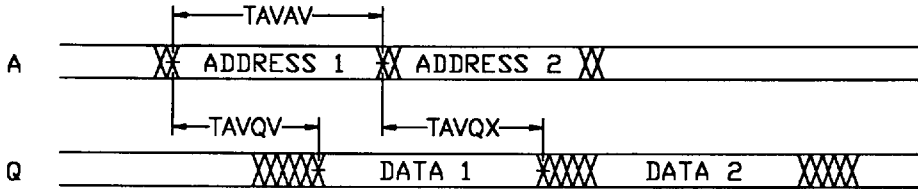

Read Cycle 2: $\overline{WE}=\text{VIH}$

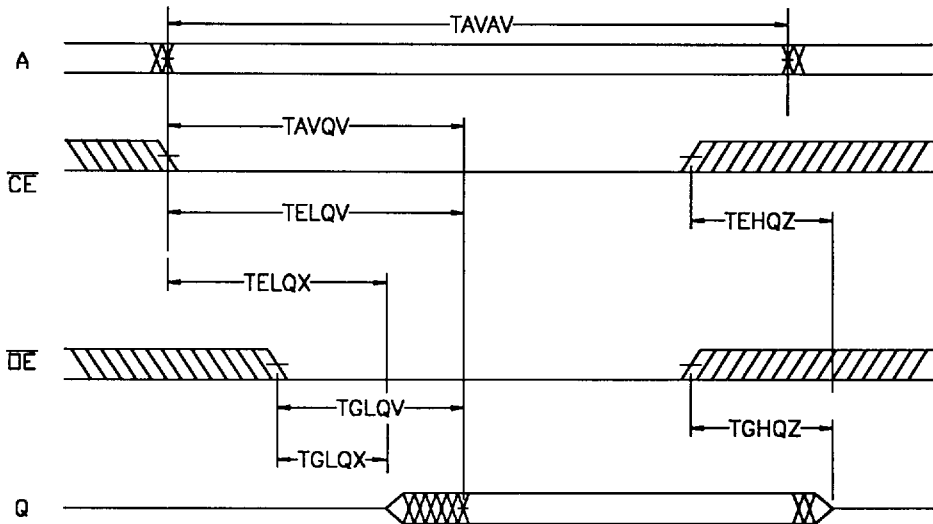

Write Cycle Timing

Write Cycle 1: \overline{WE} Control

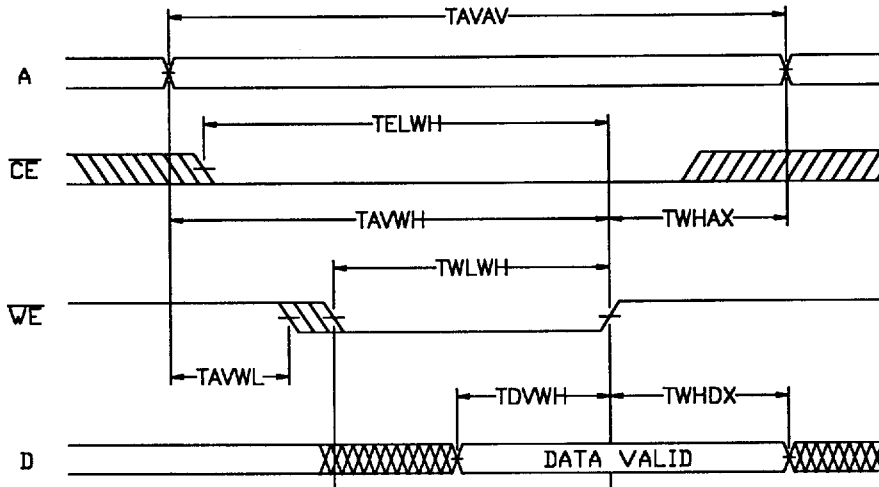

Write Cycle 2: \overline{CE} Control

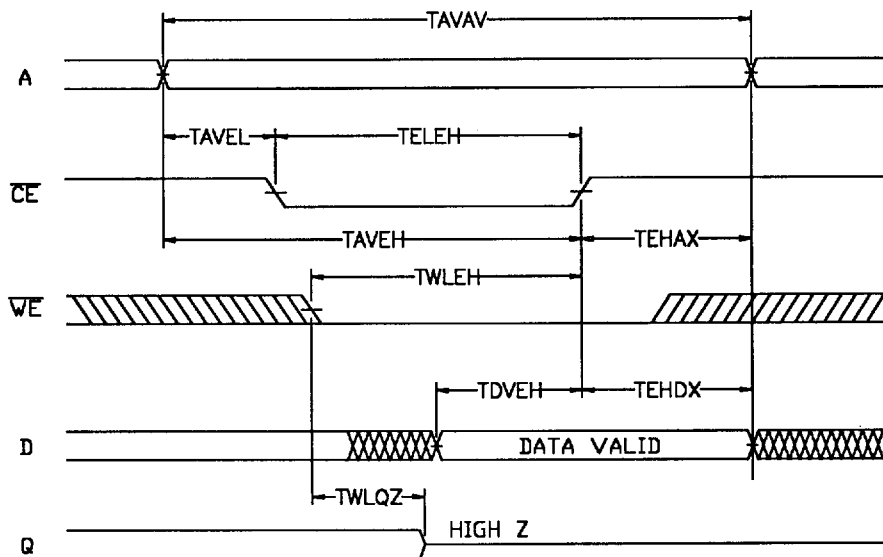

ELPAQ

ELPAQ T-46-23-14

EMS256K8A

A division of ELMO Semiconductor Corp.

20 - 35ns

NOTES:

ORDERING INFORMATION

EMS256K8A

MO2

-25

C

Temperature Range

- C = Commercial (0 - 70°C)
- I = Industrial (-40 - +85°C)
- D = MIL Temp (-55 - +125°C)
- M = MIL Screen (-55 - +125°C)

Speed

- 20 = 20ns Access Time
- 25 = 25ns Access Time
- 35 = 35ns Access Time

Package

- MO2 = .600" 32 Lead Ceramic DIP
- MO6 = .600" 32 Lead Plastic DIP