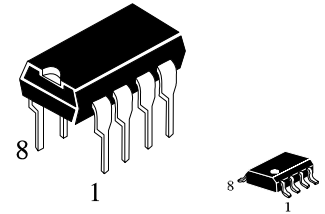


# IL33193

## AUTOMOTIVE DIRECTION INDICATOR

The IL33193 is a new generation industry standard UAA1041 "Flasher". It has been developed for enhanced EMI sensitivity, system reliability, and improved wiring simplification. The IL33193 is pin compatible with the UAA1041 and UAA1041B in the standard application configuration as shown in Figure 9, without lamp short circuit detection and using a 20 mΩ shunt resistor. The IL33193 has a standby mode of operation requiring very low standby supply current and can be directly connected to the vehicle's battery. It includes an RF filter on the Fault detection pin (Pin 7) for EMI purposes. Fault detection thresholds are reduced relative to those of the UAA1041, allowing a lower shunt resistance value (20 mΩ) to be used.

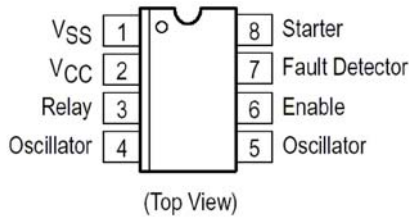


NSuffix	D Suffix
Plastic DIP	SO-8
IL33193N	Plastic DIP
IL33193D	SO-8

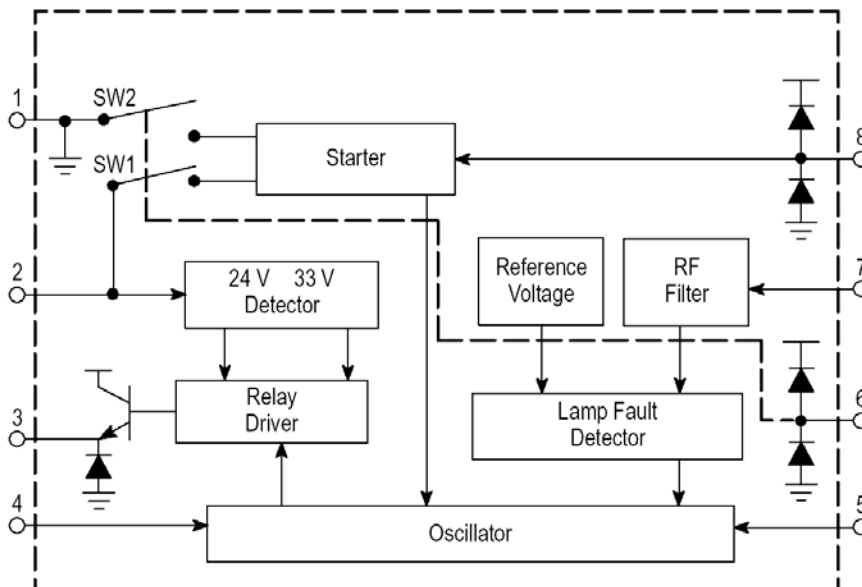
T<sub>A</sub> = -40 to 125 C for all packages

- Pin Compatible with the UAA1041
- Defective Lamp Detection Threshold
- RF Filter for EMI Purposes
- Load Dump Protection
- Double Battery Capability for Jump Start Protection
- Internal Free Wheeling Diode Protection
- Low Standby Current Mode

### Pin connections



### Simplified Block Diagram



This device contains 60 active transistors.

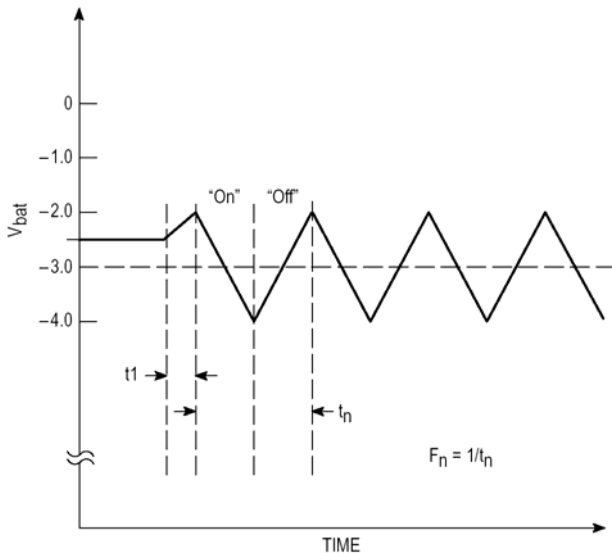
## MAXIMUM RATINGS

Rating	Symbol	Value	Unit
Pin 1 Positive Current (Continuous/Pulse)	I1+	150 to 500	mA
Pin 1 Negative Current (Continuous/Pulse)	I1-	-35 to -500	mA
Pin 2 Current (Continuous/Pulse)	I2	±350 to ±1900	mA
Pin 3 Current (Continuous/Pulse)	I3	±300 to ±1400	mA
Pin 8 Current (Continuous/Pulse)	I8	±25 to ±50	mA
ESD (All Pins Except Pin 4 for Negative Pulse)	V <sub>J</sub>	±2000	V
ESD (Pin 4 Negative Pulse)	V <sub>ESD4-</sub>	-1000	V
Junction Temperature	T <sub>J</sub>	150	°C
Operation Ambient Temperature Range	T <sub>A</sub>	-40 to +125	°C
Storage Temperature Range	T <sub>stg</sub>	-65 to +150	°C

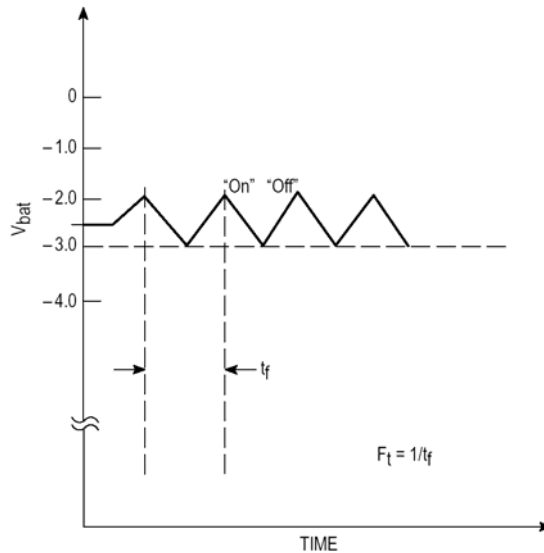
## ELECTRICAL CHARACTERISTICS

(-40°C ≤ T<sub>A</sub> ≤ +125°C, 8.0 V ≤ V<sub>CC</sub> ≤ 18 V, unless otherwise noted. Typical values reflect approximate mean at T<sub>A</sub> = 25°C, V<sub>CC</sub> = 14 V at the time of initial device characterization.)

Characteristic	Symbol	Min	Typ	Max	Unit
Battery Voltage Range (Normal Operation)	V <sub>b</sub>	8.0	-	18	V
Overvoltage Detector Threshold (VPin2 – VPin1)	V <sub>ih</sub>	19	20.2	22	V
Clamping Voltage (R2 = 220 Ω)	V <sub>cl</sub>	27	29.2	34	V
Output Voltage [I = -250 mA (VPin2 – VPin3)]	V <sub>sat</sub>	-	-	1.5	V
Starter Resistance (R <sub>st</sub> = R2 + RLamp)	R <sub>st</sub>	-	3.3	3.6	kΩ
Oscillator Constant (Normal Operation, T <sub>A</sub> = 25°C)	K <sub>n</sub>	1.3	1.5	1.75	X
Temperature Coefficient of Kn	TC <sub>Kn</sub>	-	0.001	-	1/°C
Duty Cycle (Normal Operation)	-	45	50	55	%
Oscillator Constant (One 21 W Lamp Defect, T <sub>A</sub> = 25°C)	K <sub>f</sub>	0.63	0.68	0.73	X
Duty Cycle (One 21 W Lamp Defect)	-	35	40	45	%
Oscillator Constant (T <sub>A</sub> = 25°C)	K1 K2	0.167 0.250	0.180 0.270	0.193 0.290	-
Standby Current (Ignition "Off")	I <sub>cc</sub>	-	2.0	100	μA
Current Consumption (Relay "Off," Enable Pin 6 High) Vbat = 8.0 V, R3 = 220 Ω, T <sub>A</sub> = 25°C Vbat = 13.5 V, R3 = 220 Ω Vbat = 18 V, R3 = 220 Ω, T <sub>A</sub> = 25°C	I <sub>cc</sub>	-	1.40 2.16 2.64	- 3.5 -	mA
Current Consumption (Relay "On") Vbat = 8.0 V, R3 = 220 Ω, T <sub>A</sub> = 25°C Vbat = 13.5 V, R3 = 220 Ω Vbat = 18 V, R3 = 220 Ω, T <sub>A</sub> = 25°C	I <sub>cc</sub>	-	1.62 2.06 3.30	- 6.0 -	mA
Defect Lamp Detector Threshold [R3 = 220 Ω, (VPin2 – VPin7)] Vbat = 8.0 V, T <sub>A</sub> = 25°C Vbat = 13.5 V Vbat = 18 V, T <sub>A</sub> = 25°C	V <sub>s</sub>	- 46.5 -	43.6 51.0 57.0	- 56 -	mV
Temperature Coefficient of V <sub>s</sub>	TC <sub>Vs</sub>	-	0.3x10 <sup>-3</sup>	-	1/°C



**Figure 1. Normal Operation Oscillator Timing Diagram**



**Figure 2. One Defective Lamp Oscillator Timing Diagram**

**INTRODUCTION**

The IL33193 is designed to drive the direction indicator flasher relay. It is a new generation industry standard UAA1041 “Flasher”. It consists of the following functions:

- Supply and Protections
- On–Chip Relay Driver
- Oscillator
- Starter Functions
- Lamp Fault Detector with Internal RF Filter

**Standby Mode**

Supply and Protection Systems

Pin 1 is connected to ground via resistor R3 which limits the current in the event of any high voltage transients. Pin 2 (VCC) is the positive supply and may be connected directly to the vehicle’s battery voltage.

**Overvoltage and Double Battery Protection:** When the applied VCC to VSS voltage is greater than 22 V, the overvoltage detector circuit turns the relay driver off. Both the device and the lamps are protected if two 12 V batteries are connected in series and used to jump start the vehicle.

**Load Dump Overvoltage Protection:** A 29 V overvoltage detector protects the circuits against high voltage transients due to load dumps and other low energy spikes. The relay driver is automatically turned on whenever the VCC to VSS voltage is greater than 34 V.

**Overvoltage Protection, High Voltage Transients:** The Enable and the Starter pins are protected against positive and negative transients by internal on–chip diodes.

**On–Chip Relay Driver**

The device directly drives the flasher relay. The output structure is an Emitter of an NPN transistor. It contains the free wheeling diode circuitry necessary to protect the device whenever the relay is switched off.

**Oscillator**

The device uses a sawtooth oscillator (Figure 1).

The frequency is determined by the external components C1 and R1. In the normal operating mode, the flashing frequency is:  $F_n = 1/R1 * C1 * K_n$ . With a defective (open) 21 W lamp (Figure 2), the flashing frequency changes to:  $F_n = 2.2 * F_n$ .

The typical first flash delay (the time between the moment when the indicator switch is closed and the first lamp flash occurs) is:  $t1 = K1 * R1 * C1$

The fault detection delay is from the time relay R1 is on and fault detection is enabled. Where a 21 W lamp opens, the delay is expressed as:  $t2 = K2 * R1 * C1$

**Starter**

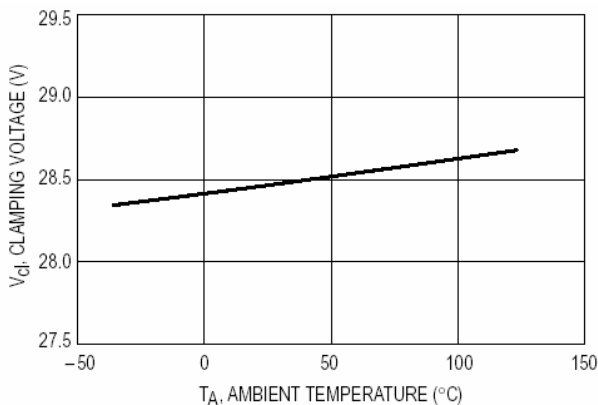
Pin 8 is connected through a 3.3 kΩ resistor to the flashing lamp. Pin 8 is the input to the Starter function and senses the use of S1 by sensing ground through the lamp (Figures 9 and 10).

**Lamp Fault Detector with Internal RF Filter**

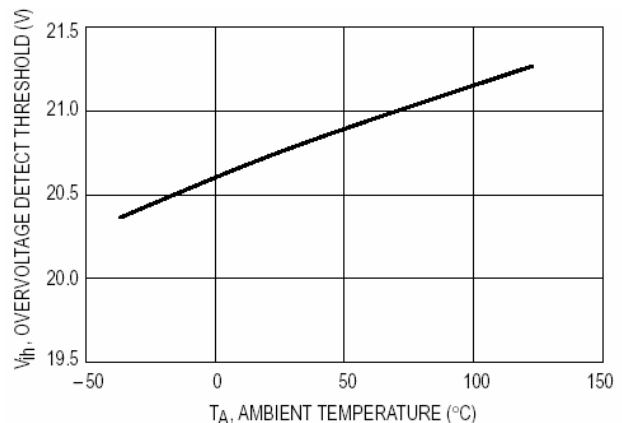
A Lamp defect is sensed by the lamp fault detector’s monitoring of the voltage developed across the external shunt resistor  $R_S$  via the RF filter. The  $R_S$  voltage drop is compared to a  $V_{bat}$  dependent internal reference voltage ( $V_{ref}$ ) to validate the comparison over the full battery voltage range. A detected fault causes the oscillator to change frequency (Figure 2).

**Standby Mode**

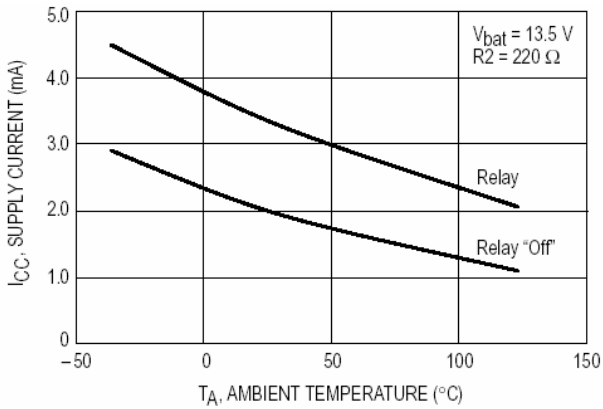
When the ignition key and warning switches are open; Enable is in a low state and the internal switches, SW1 and SW2, are open and no current passes through the circuit. In this condition, the device’s current consumption is zero ( $I_{CC} = 0$ ). When ignition key and warning switches are closed; Enable is in a high state with SW1 and SW2 being closed and the circuit is powered on.



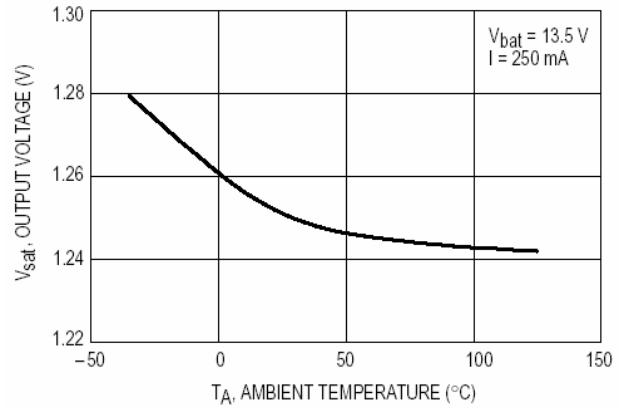
**Figure 3. Clamping Voltage versus Temperature**



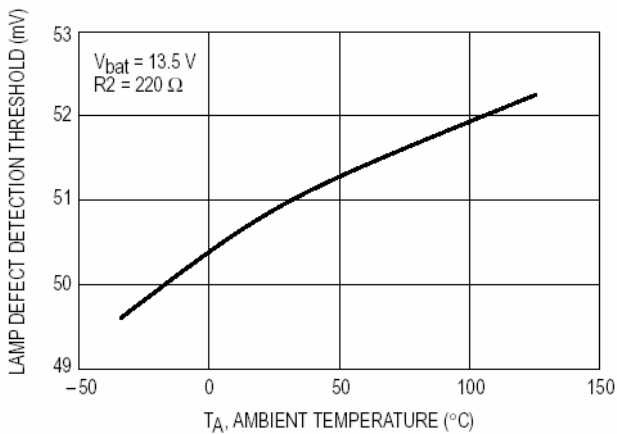
**Figure 4. Overvoltage Detection versus Temperature**



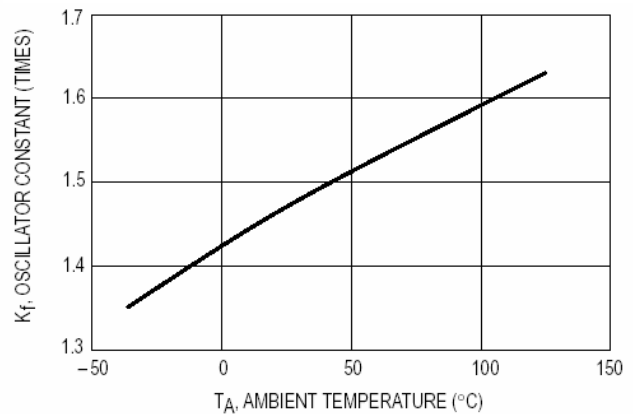
**Figure 5. Supply Current versus Temperature**



**Figure 6. Output Voltage versus Temperature**

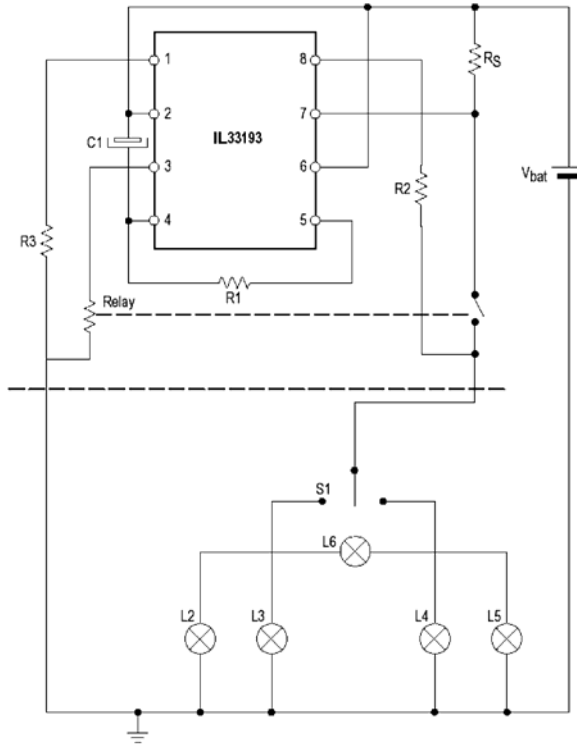


**Figure 7. Defect Lamp Detection versus Temperature**



**Figure 8. Oscillator Constant versus Temperature**

## IL33193



- $R_S = 20 \text{ m}\Omega$   
 $R_1 = 75 \text{ k}\Omega$   
 $C_1 = 5.6 \text{ }\mu\text{F}$   
 $R_2 = 3.3 \text{ k}\Omega$   
 $R_3 = 200 \text{ }\Omega$   
 $L_2, L_3, L_4, L_5 = 21 \text{ W Turn Signal Lamps}$

Figure 9. IL33193 Typical Application

### Application Information

- NOTES: 1. In the above application, the IL33193 is compatible with the UAA1041 and UAA1041B except for the shunt resistor value ( $R_S = 20 \text{ m}\Omega$ ).
2. The flashing cycle is started by the closing of switch S1.
3. The position of switch S1 is sensed across resistor R2 and RLamp by the input, Pin 8.

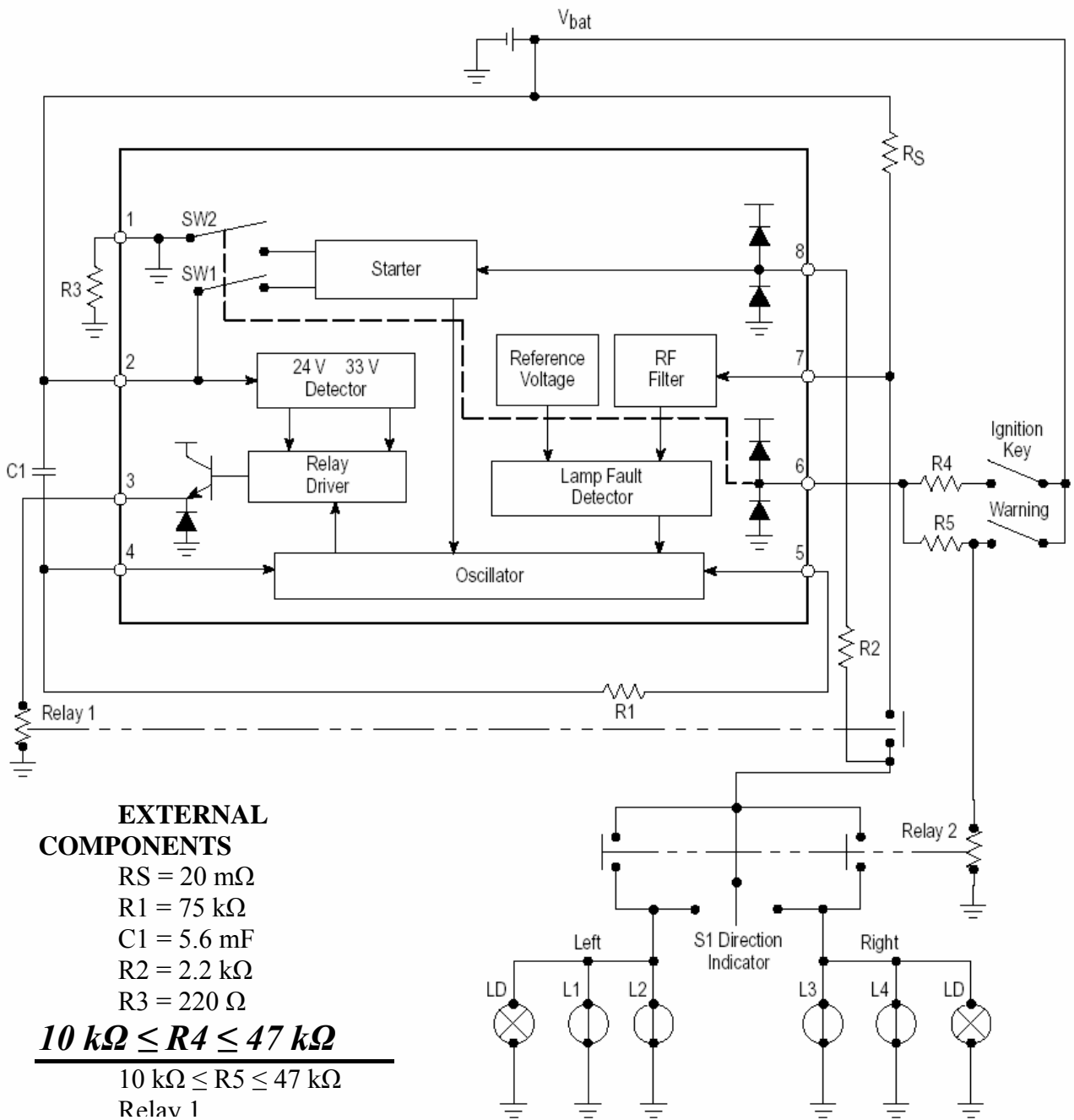


Figure 10. Typical IL33193 Application

**Application Information**

- NOTES:**
1. The flashing cycle is started by the closing of switch S1.
  2. The S1 switch position is sensed across the resistor R2 and  $R_{Lamp}$  by the input (Pin 8).
  3. If the logic state at Pin 6 is [0], the current through R2 is off.