

CMOS 5x7 Alphanumeric Displays

Technical Data

HCMS-200X Series HCMS-230X Series

Features

- **On-Board Low Power CMOS IC:**
Integrated Shift Register with Constant Current LED Drivers
- **Wide Operating Temperature Range:**
-40°C to +85°C
- **Compact Glass Ceramic 4 Character Package:**
HCMS-200X Series End Stackable
HCMS-230X Series X-Y Stackable
- **Five Colors:**
Standard Red
High Efficiency Red
Orange
Yellow
High Performance Green
- **5 X 7 LED Matrix Displays Full ASCII Set**
- **Two Character Heights:**
3.8mm (0.15 inch)
5.0mm (0.20 inch)
- **Wide Viewing Angle:**
X Axis = $\pm 50^\circ$
Y Axis = $\pm 65^\circ$
- **Long Viewing Distance:**
HCMS-200X Series to 2.6 Meters (8.6 Feet)
HCMS-230X Series to 3.5 Meters (11.5 Feet)
- **Categorized for Luminous Intensity**

- **HCMS-2001/-2003, HCMS-2301/-2303:**
Categorized for Color

Typical Applications

- Commercial Avionics
- Instrumentation
- Medical Instruments
- Business Machines

Description

The HCMS-200X and HCMS-230X series are 5x7 LED four character displays contained in 12 pin dual-in-line packages designed for displaying alphanumeric information. The character height for the HCMS-200X series displays is 3.8mm (0.15

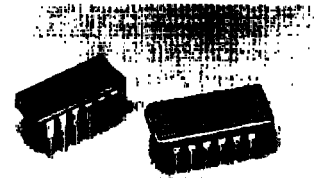

inch), and for the HCMS-230X series displays the character height is 5.0mm (0.20 inch). These displays are available in all five LED colors: standard red, high efficiency red, orange, yellow and high performance green. The HCMS-200X series displays are end stackable and the HCMS-230X series displays are end/row stackable.

Display Selection Table

Part Number	Character Size	LED Color
HCMS-2000	3.8 mm (0.15 inch)	Standard Red
HCMS-2001	3.8 mm (0.15 inch)	Yellow
HCMS-2002	3.8 mm (0.15 inch)	High-Efficiency Red
HCMS-2003	3.8 mm (0.15 inch)	High-Performance Green
HCMS-2004	3.8 mm (0.15 inch)	Orange
HCMS-2300	5.0 mm (0.20 inch)	Standard Red
HCMS-2301	5.0 mm (0.20 inch)	Yellow
HCMS-2302	5.0 mm (0.20 inch)	High-Efficiency Red
HCMS-2303	5.0 mm (0.20 inch)	High-Performance Green
HCMS-2304	5.0 mm (0.20 inch)	Orange

ESD WARNING: STANDARD CMOS HANDLING PRECAUTIONS SHOULD BE OBSERVED.

These displays are designed with on-board CMOS integrated circuits for use in applications where conservation of power is important. The two CMOS ICs form an on-board serial-in-parallel-out 28-bit shift register with constant current output LED row drivers. Decoded column data is clocked into the

on-board shift register for each refresh cycle. Full character display is achieved with external column strobing.

Compatibility with HDSP-200X/230X TTL IC Series Displays

The HCMS-200X, HCMS-230X CMOS IC displays are "drop-in"

replacements for the equivalent HDSP-200X, HDSP-230X TTL IC displays. The 12 pin glass/ceramic package configuration, four digit character matrix and pin functions are identical.

Package Dimensions

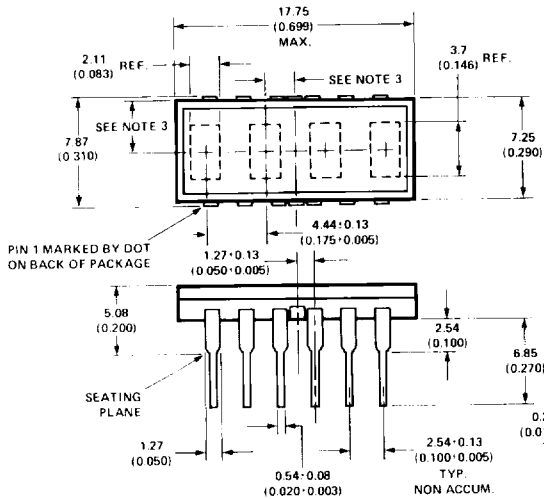

PIN	FUNCTION	PIN	FUNCTION
1	COLUMN 1	7	DATA OUT
2	COLUMN 2	8	V _B
3	COLUMN 3	9	V _{DD}
4	COLUMN 4	10	CLOCK
5	COLUMN 5	11	GROUND
6	INT. CONNECT*	12	DATA IN

* DO NOT CONNECT OR USE

HCMS-200X Series

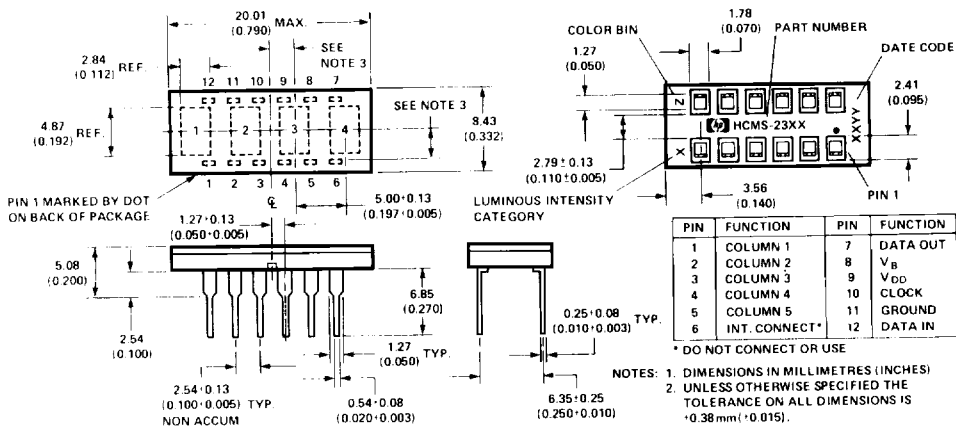

PIN	FUNCTION	PIN	FUNCTION
1	COLUMN 1	7	DATA OUT
2	COLUMN 2	8	V _B
3	COLUMN 3	9	V _{DD}
4	COLUMN 4	10	CLOCK
5	COLUMN 5	11	GROUND
6	INT. CONNECT*	12	DATA IN

* DO NOT CONNECT OR USE

- NOTES: 1. DIMENSIONS IN MILLIMETRES (INCHES)
 2. UNLESS OTHERWISE SPECIFIED THE TOLERANCE ON ALL DIMENSIONS IS ±0.38mm (±0.015).
 3. CHARACTERS ARE CENTERED WITH RESPECT TO LEADS WITHIN ±0.13mm (±0.005").
 4. LEAD MATERIAL IS COPPER ALLOY, SOLDER DIPPED.

HCMS-230X Series

Absolute Maximum Ratings

Supply Voltage V_{DD} to Ground	-0.3 V to 7.0 V
Data Input, Data Output, V_B	-0.3 V to V_{DD}
Column Input Voltage, V_{COL}	-0.3 V to V_{DD}
Free Air Operating Temperature Range, T_A	-40°C to +85°C
Storage Temperature Range, T_S	-55°C to +100°C
Maximum Allowable Package Power Dissipation, $P_D^{(1,2)}$	
HCMS-2000/-2001/-2002/-2003/-2004 at $T_A = 78^\circ\text{C}$	0.79 Watts
HCMS-2300 at $T_A = 85^\circ\text{C}$	0.79 Watts
HCMS-2301/-2302/-2303/-2304 at $T_A = 85^\circ\text{C}$	0.92 Watts
Maximum Solder Temperature	
1.59 mm (0.063") Below Seating Plane, $t < 5$ sec	260°C
ESD Protection @ 1.5 k Ω , 100 pF	$V_z = 4$ kV (each pin)

Notes:

- Maximum allowable power dissipation is derived from $V_{DD} = 5.25$ V, $V_B = 2.4$ V, $V_{COL} = 3.5$ V, 20 LEDs on per character, 20% DF.
 - The power dissipation for these displays should be derated as follows:
 - HCMS-200X series derate above 78°C at 18 mW/°C, $R\theta_{JA} = 60^\circ\text{C/W}$.
 - HCMS-230X series may be operated without derating up to $T_A = 85^\circ\text{C}$, $R\theta_{JA} = 45^\circ\text{C/W}$.
- Deratings based on $R\theta_{PC,A} = 35^\circ\text{C/W}$ per display for printed circuit board assembly.
See Figure 1 for power derating.

Recommended Operating Conditions Over Operating Temperature Range (-40°C to +85°C)

Parameter	Symbol	Min.	Typ.	Max.	Units
Supply Voltage	V_{DD}	4.75	5.00	5.25	V
Data Out Current, Low State	I_{OL}			1.6	mA
Data Out Current, High State	I_{OH}			-0.5	mA
Column Input Voltage	V_{COL}	2.75	3.0	3.5	V
Setup Time	t_{SETUP}	10			ns
Hold Time	t_{HOLD}	25			ns
Clock Pulse Width High	$t_{WH(CLOCK)}$	50			ns
Clock Pulse Width Low	$t_{WL(CLOCK)}$	50			ns
Clock High to Low Transition	t_{THL}			200	ns
Clock Frequency	f_{CLOCK}			5	MHz

Electrical Characteristics Over Operating Temperature Range (-40°C to +85°C)

Parameter	Symbol	Test Conditions	Min.	Typ.*	Max.	Units
Supply Current, Dynamic ⁽¹⁾	I_{DD}	$f_{CLOCK} = 5 \text{ MHz}$		6.2	7.8	mA
Supply Current, Static ⁽²⁾	$I_{DD\text{Soff}}$ $I_{DD\text{Son}}$	$V_B = 0.4 \text{ V}$ $V_B = 2.4 \text{ V}$		1.8 2.2	2.6 3.3	mA
Column Input Current	I_{COL}	$V_B = 0.4 \text{ V}$			10	μA
HCMS-2000/-2001/-2002/-2003/-2004		$V_B = 2.4 \text{ V}$		310	384	mA
HCMS-2300		$V_B = 2.4 \text{ V}$		310	384	
HCMS-2301/-2302/-2303/-2304		$V_B = 2.4 \text{ V}$		360	451	mA
Input Logic High Data, V_B , Clock	V_{IH}	$V_{DD} = 4.75 \text{ V}$	2.0			V
Input Logic Low Data, V_B , Clock	V_{IL}	$V_{DD} = 5.25 \text{ V}$			0.8	V
Input Current Data, Clock V_B	I_I	$V_{DD} = 5.25 \text{ V}$ $0 < V_I < 5.25 \text{ V}$ $0 < V_B < 5.25 \text{ V}$	-10 -40		+1 0	μA
Data Out Voltage	V_{OH} V_{OL}	$V_{DD} = 4.75 \text{ V}$ $I_{OH} = -0.5 \text{ mA}$ $I_{COL} = 0 \text{ mA}$	2.4	4.2		V
		$V_{DD} = 5.25 \text{ V}$ $I_{OL} = 1.6 \text{ mA}$ $I_{COL} = 0 \text{ mA}$		0.2	0.4	
Power Dissipation Per Package ⁽³⁾ HCMS-2000/-2001/-2002/-2003/-2004 HCMS-2300 HCMS-2301/-2302/-2303/-2304	P_D	$V_{DD} = 5.0 \text{ V}$ $V_{COL} = 3.5 \text{ V}$ 17.5% DF $V_B = 2.4 \text{ V}$ 15 LEDs ON per Character		414 414 481		mW
Thermal Resistance IC Junction-to-Pin ⁽⁴⁾ HCMS-2000/-2001/-2002/-2003/-2004 HCMS-2300/-2301/-2302/-2303/-2304	$R\theta_{J-PIN}$			25 10		$^{\circ}\text{C/W}$

*All typical values specified at $V_{DD} = 5.0 \text{ V}$ and $T_A = 25^{\circ}\text{C}$.

Notes:

- I_{DD} Dynamic is the IC current while clocking column data through the on-board shift register at a clock frequency of 5MHz, the display is not illuminated.
- I_{DD} Static is the IC current after column data is loaded and not being clocked through the on-board shift register.
- Four characters are illuminated with a typical ASCII character composed of 15 dots per character.
- IC junction temperature $T_J(\text{IC}) = (P_D)(R\theta_{J-PIN} + R\theta_{PC-A}) + T_A$

Optical Characteristics at $T_A = 25^\circ\text{C}$

Standard Red HCMS-2000/-2300

Description	Symbol	Test Condition	Min.	Typ.*	Max.	Units
Peak Luminous Intensity per LED ^(5,9) HCMS-2000 HCMS-2300 (Character Average)	I_{VPEAK}	$V_{DD} = 5.0\text{ V}$ $V_{COL} = 3.5\text{ V}$ $V_B = 2.4\text{ V}$ $T_i = 25^\circ\text{C}^{(7)}$	105 130	200 300		μcd
Dominant Wavelength ⁽⁸⁾	λ_d			639		nm
Peak Wavelength	λ_{PEAK}			655		nm

Yellow HCMS-2001/-2301

Description	Symbol	Test Condition	Min.	Typ.*	Max.	Units
Peak Luminous Intensity per LED ^(5,9) HCMS-2001 HCMS-2301 (Character Average)	I_{VPEAK}	$V_{DD} = 5.0\text{ V}$ $V_{COL} = 3.5\text{ V}$ $V_B = 2.4\text{ V}$ $T_i = 25^\circ\text{C}^{(7)}$	400 650	750 1140		μcd
Dominant Wavelength ^(6,8)	λ_d			585		nm
Peak Wavelength	λ_{PEAK}			583		nm

High Efficiency Red HCMS-2002/-2302

Description	Symbol	Test Condition	Min.	Typ.*	Max.	Unit
Peak Luminous Intensity per LED ^(5,9) HCMS-2002 HCMS-2302 (Character Average)	I_{VPEAK}	$V_{DD} = 5.0\text{ V}$ $V_{COL} = 3.5\text{ V}$ $V_B = 2.4\text{ V}$ $T_i = 25^\circ\text{C}^{(7)}$	400 650	1430 1430		μcd
Dominant Wavelength ⁽⁸⁾	λ_d			625		nm
Peak Wavelength	λ_{PEAK}			635		nm

High Performance Green HCMS-2003/-2303

Description	Symbol	Test Condition	Min.	Typ.*	Max.	Units
Peak Luminous Intensity per LED ^(5,9) HCMS-2003 HCMS-2303 (Character Average)	I_{VPEAK}	$V_{DD} = 5.0\text{ V}$ $V_{COL} = 3.5\text{ V}$ $V_B = 2.4\text{ V}$ $T_i = 25^\circ\text{C}^{(7)}$	850 1280	1550 2410		μcd
Dominant Wavelength ^(6,8)	λ_d			574		nm
Peak Wavelength	λ_{PEAK}			568		nm

Orange HCMS-2004/-2304

Description	Symbol	Test Condition	Min.	Typ.*	Max.	Units
Peak Luminous Intensity per LED ^(5,9) HCMS-2004 HCMS-2304 (Character Average)	I_{VPEAK}	$V_{DD} = 5.0\text{ V}$ $V_{COL} = 3.5\text{ V}$ $V_B = 2.4\text{ V}$ $T_i = 25^\circ\text{C}^{(7)}$	400 650	1430 1430		μcd
Dominant Wavelength ⁽⁸⁾	λ_d			602		nm
Peak Wavelength	λ_{PEAK}			600		nm

*All typical values specified at $V_{DD} = 5.0\text{ V}$ and $T_A = 25^\circ\text{C}$ unless otherwise noted.

Notes:

- These LED displays are categorized for luminous intensity, with the intensity category designated by a letter code on the back of the package.
- The HCMS-2001/-2301 and HCMS-2003/-2303 are categorized for color with the color category designated by a number on the back of the package.
- T_i refers to the initial case temperature of the display immediately prior to the light measurement.
- Dominant wavelength, λ_d , is derived from the CIE Chromaticity Diagram, and represents the single wavelength which defines the color of the device.
- The luminous sterance of the individual LED pixels may be calculated using the following equations:

$$L_v(\text{cd/m}^2) = I_v(\text{Candela}) * \text{DF} / \text{A}(\text{Metre})^2$$

$$L_v(\text{Footlamberts}) = \pi I_v(\text{Candela}) * \text{DF} / \text{A}(\text{Foot})^2$$

Where: A = LED pixel area = $5.3 \times 10^{-8}\text{M}^2$ or $5.8 \times 10^{-7}\text{ft}^2$
DF = LED on-time duty factor

Switching Characteristics, $T_A = -40^\circ\text{C}$ to $+85^\circ\text{C}$

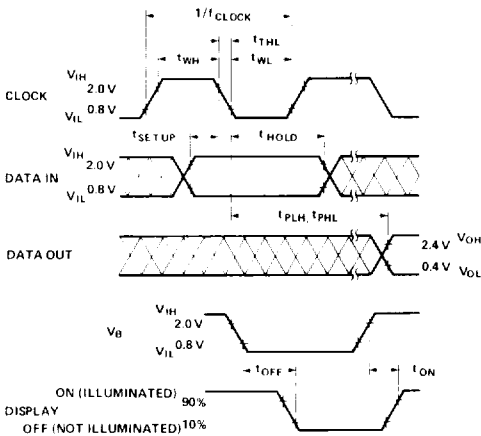

Parameter	Condition	Typ.	Max.	Units
f_{CLOCK} CLOCK Rate			5	MHz
t_{PLH} , t_{PHL} Propagation Delay CLOCK to DATA OUT	$C_L = 15\text{ pF}$ $R_L = 2.4\text{ k}\Omega$		105	ns
t_{OFF} V_B (0.4 V) to Display OFF t_{ON} V_B (2.4 V) to Display ON		4 1	5 2	μs

ALPHANUMERIC DISPLAYS

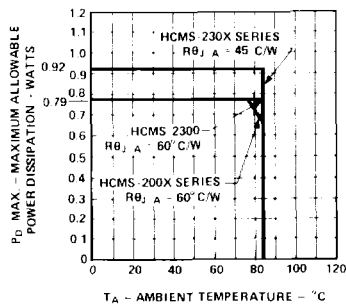

Figure 1. Maximum Allowable Power Dissipation vs Ambient Temperature as a Function of Thermal Resistance Junction-to-Ambient, $R_{\theta JA}$. Derated Operation Assumes $R_{\theta PC-A} = 35^{\circ}\text{C/W}$ Per Display for the Printed Circuit Board. T_J (IC) MAX = 125°C .

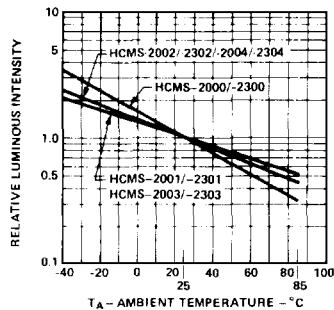

Figure 2. Relative Luminous Intensity vs Display Pin Temperature

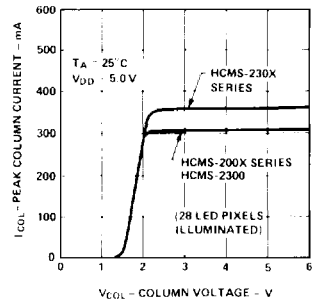

Figure 3. Peak Column Current vs Column Voltage

Electrical Description

Each display device contains four 5x7 LED dot matrix characters and two CMOS integrated circuits, as shown in Figure 4. The two CMOS integrated circuits form an on-board 28 bit serial-in-parallel-out shift register that will accept standard TTL logic levels. The Data Input, pin 12, is connected to bit position 1 and the Data Output, pin 7, is connected to bit position 28. The shift register outputs control constant current sinking LED row drivers. The nominal current sink per LED driver is 11mA for the HCMS-200X displays, 13 mA for the HCMS-230X. A logic 1 stored in the shift register enables the corresponding LED row driver and a logic 0 stored in the shift register disables the corresponding LED row driver.

The electrical configuration of these CMOS IC alphanumeric displays allows for an effective

interface to a display controller circuit that supplies decoded character information. The row data for a given column (one 7 bit byte per character) is loaded (bit serial) into the on-board 28 bit shift register with high to low transitions of the Clock input. To load decoded character information into the display, column data for character 4 is loaded first and the column data for character 1 is loaded last in the following manner. The 7 data bits for column 1, character 4, are loaded into the on-board shift register. Next, the 7 data bits for column 1, character 3, are loaded into the shift register, shifting the character 4 data over one character position. This process is repeated for the other two characters until all 28 bits of column data (four 7 bit bytes of character column data) are loaded into the on-board shift register. Then the column 1 input, V_{COL} pin 1, is energized to illuminate column 1 in all

four characters. This process is repeated for columns 2, 3, 4 and 5. All V_{COL} inputs should be at logic low to insure the display is off when loading data. The display will be blanked when the blanking input V_B , pin 8, is at logic low regardless of the outputs of the shift register or whether one of the V_{COL} inputs is energized.

Refer to Application Note 1016 for drive circuit information.

ESD Susceptibility

The HCMS-200X/-230X series displays have an ESD susceptibility ratings of CLASS 3 per DOD-STD-1686 and CLASS B per MIL-STD-883C. It is recommended that normal CMOS handling precautions be observed with these devices.

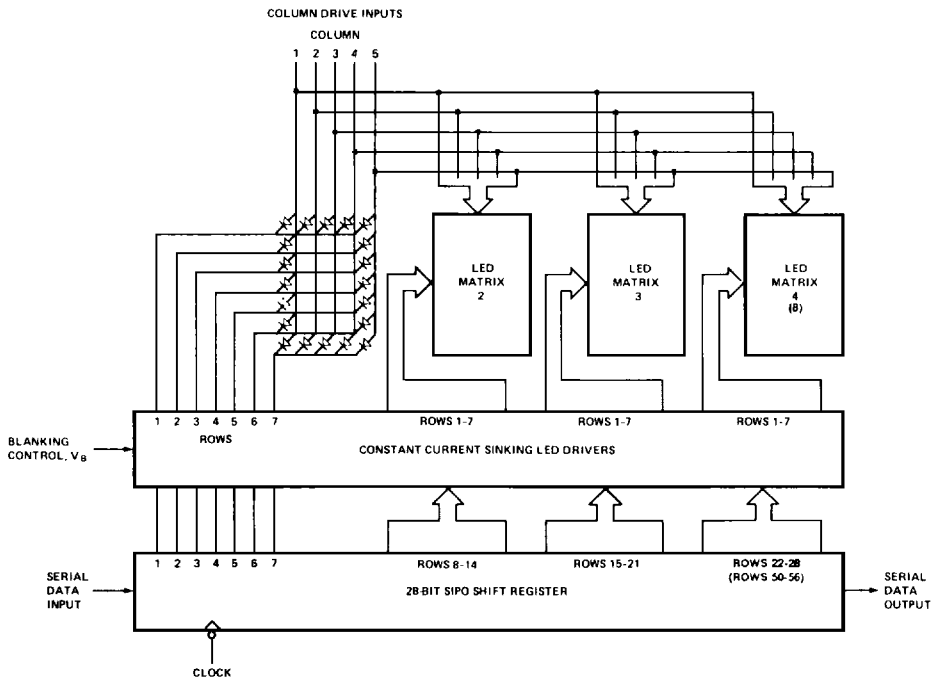

Figure 4. Block Diagram of an HCMS-2XXX Series LED Alphanumeric Display.

Soldering and Post Solder Cleaning

These displays may be soldered with a standard wave solder process using either an RMA flux and solvent cleaning or an OA flux and aqueous cleaning. For optimum soldering, the solder wave temperature should be 245°C and the dwell time for any display lead passing through the wave should be 1 1/2 to 2 seconds. The recommended solvent for post solder cleaning is Genesolv DES, manufactured by Allied Chemical. For aqueous cleaning, a water temperature of 60°C

(140°F) with an immersion time not exceeding 15 minutes is recommended. For more detailed information, refer to Application Note 1027 *Soldering LED Components*.

Contrast Enhancement

When used with the proper contrast enhancement filters, the HCMS-200X/-230X series displays are readable in bright ambients. Refer to Application Note 1029 *Luminous Contrast and Sunlight Readability of the HDSP-238X Series Alphanumeric Displays for Military Applications* for contrast en-

hancement in bright ambients. Refer to Application Note 1015 *Contrast Enhancement Techniques for LED Displays* for information on contrast enhancement in moderate ambients.

Controller Circuits, Power Calculations and Display Dimming

Refer to Application Note 1016 *Using the HDSP-2000 Alphanumeric Display Family* for information on controller circuits to drive these displays, how to do power calculations and a technique for display dimming.