

PRODUCT NUMBER

XXXXX-YYY HTLF

- LEAD FREE OPTION
SEE NOTE 1,8
- TUBE PACKAGING OPTION
SEE NOTE 1
- HIGH TEMPERATURE PLASTIC
SEE NOTE 1
- NO OF POSITIONS
SEE NOTE 1
- PIN PLATING
SEE SHEET 2
- BASE PART NO.

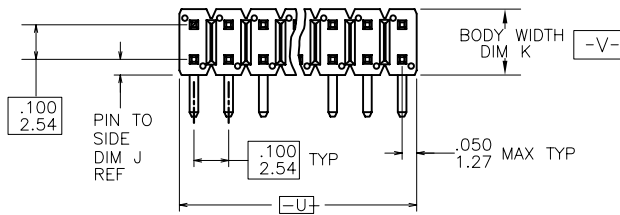

TOP VIEW

$\varnothing .020 / .51$ (M) U (M) V W
NOTE 4

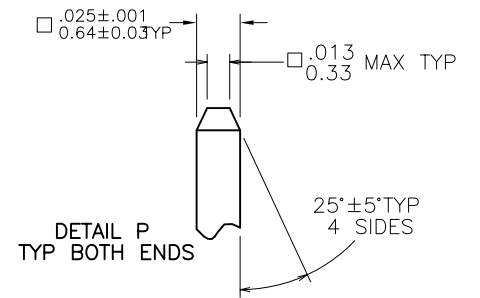

DETAIL P
TYP BOTH ENDS

68020-X XX-XXX XXX LF

- TAIL LENGTH (EXAMPLE BELOW)
3.0mm=030 12.8mm=128 (SEE NOTE 11 & 12)
- MATING LENGTH (EXAMPLE BELOW)
5.0mm=050 25.5mm=255 (SEE NOTE 11 & 12)
- TOTAL NUMBER OF POSITION
FROM 2(2X1) THRU 72 (2X36) POSITIONS
- PIN PLATING (SEE NOTE 9)
1=0.76µm Au
4= PURE TIN
8=0.36µm Au
- BASE PART NO.

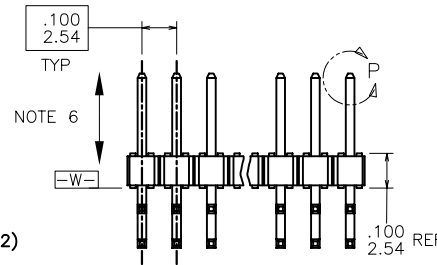

SIDE VIEW

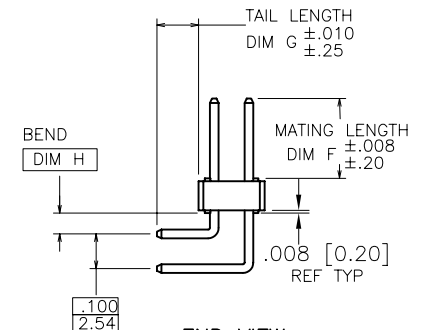

END VIEW

mat'l. code NOTES 2 & 3				surface ISO 1302	tolerance ISO 406 ISO 1101	projection INCH/MM	product family BERGSTIK
ltr	ecn no	dr	date	tolerances unless otherwise specified		scale 1:1	title BERGSTIK® II HEADER .100/2.54cc DR R/A
AX	v21800	TAB	12/20/02	angles	linear		dwg no 68020
AY	M04-0234	MHT	12/29/04				sheet 1 of 5 size A3
BA	M05-0072	MHT	5/03/05	0°±2'			type Product Customer Drawing
BB	M06-0268	MHT	7/17/06	dr	D.WIHTING	03/08/93	
BC	M06-0346	MHT	9/04/06	engr	T.HANNA	03/08/93	
BD	M07-0165	AGS	3/22/07	chr	T.BREWNAKER	03/08/93	
BE	M08-0169	MHT	3/05/07	appd	T.HANNA	03/08/93	
sheet	revision	BE	BE	BE	BE	BE	
index	sheet	1	2	3	4	5	

PIN PLATING CODES:	
XXXXX-1YY	30u"/0.76u MIN (SEE NOTE 9) OVER 50u"/1.27u MIN Ni
XXXXX-2YY	15u"/0.38u MIN (SEE NOTE 9) OVER 50u"/1.27u MIN Ni
XXXXX-3YY	50u"/1.27u MIN Au OVER 50u"/1.27u MIN Ni
XXXXX-4YY	100u"/2.54u MIN Sn OVER 50u"/1.27u MIN Ni (SEE NOTE 10)
XXXXX-4YYHLF	
XXXXX-5YY	15u"/0.38u MIN (SEE NOTE 9) OVER 50u"/1.27u MIN Ni
XXXXX-6YY	30u"/0.76u MIN (SEE NOTE 9) OVER 50u"/1.27u MIN Ni
XXXXX-7YY	30u"/0.76u MIN Au OVER 50u"/1.27u MIN Ni
XXXXX-8YY	15u"/0.38u MIN Au OVER 50u"/1.27u MIN Ni
XXXXX-9YY	15u"/0.38u MIN GXT OVER 50u"/1.27u MIN Ni
XXXXX-0YY	30u"/0.76u MIN GXT OVER 50u"/1.27u MIN Ni

NOTES

1. PART NUMBER OPTIONS:

PIN PLATING CODES (SEE ABOVE)

HIGH TEMP. MATERIAL:

FOR HIGH-TEMPERATURE APPLICATIONS, SPECIFY AN "H" AT THE END OF THE PART NUMBER, AND PCT WILL BE SUPPLIED.

NUMBER OF POSITION:

EVEN NUMBER OF POSITIONS FROM 2 (2X1) THRU 72 (2X36).

PACKAGING:

PACKAGED IN POLY BAGS.

EIGHT DIGIT PART NUMBERS FOLLOWED BY A "T" ARE PACKAGED IN TUBES. SEE SPECIFIC PART NUMBERS FOR AVAILABILITY.

LEAD FREE:

ADD "HLF" SUFFIX AT THE END OF PART NUMBER FOR LEAD FREE OPTION, NOT AVAILABLE FOR -5YY,-5YYH,-6YY & -6YYH.

2. BODY MATERIAL:

MANUFACTURER'S OPTION OF NYLON OR PCT, GLASS FIBER REINFORCED, FLAME RETARDENT PER UL-94V-0. COLOR: BLACK.

PART NUMBERS WITH "H" SUFFIX WILL WITHSTAND EXPOSURE TO 260°C PEAK TEMPERATURE FOR 20 SECONDS IN WAVE SOLDER, INFRA-RED OR VAPOR PHASE SOLDER PROCESS.

PART NUMBERS WITHOUT "H" SUFFIX WILL WITHSTAND EXPOSURE TO 260°C PEAK TEMPERATURE FOR WAVE SOLDER PROCESS.

3. PIN MATERIAL: PHOS-BRONZE.

4. MEASURED WITH PART IN RESTRAINED CONDITION.

5. TWO SIDES OF PIN TIPS NOT PLATED. TYPICAL BOTH ENDS.

6. 2LBS/0.9KG MIN PIN RETENTION IN EITHER DIRECTION.

7. MILITARY BERGSTIK HEADER
P/N XXXXX-XY-MIL
NOT AVAILABLE.

8. THESE PRODUCTS MEETS EUROPEAN UNION DIRECTIVES AND OTHER COUNTRY REGULATION AS DESCRIBED IN GS-22-008.

9. PLATING OPTIONS:
MAY BE EITHER GOLD OR GXT PLATED AT MANUFACTURER'S OPTION.

10. THIS PRODUCT HAS 100% TIN PLATING IN THE INTERFACE AND HAS NOT BEEN TESTED FOR WHISKER GROWTH IN ALL INTERCONNECT ENVIRONMENTS."

11. THE OAL DON'T EXCEED 31mm
OAL= MATTING DIM + TAIL DIM +4.0mm<=31mm "WHERE THE SUM OF TAIL LEGTH DON'T EXCEED 27mm" TAIL
TAIL LENGTH MIN 2.00mm TAIL LENGTH MAX 10.4mm
MATTING LENGTH MIN 1.5mm MATTING LENGTH MAX 25.4mm

12. INCREMENTS BY 0.1mm IN LENGTH ONLY

13. FOR ESPECIAL PACKAGING REQUEST PLEASE CONTACT PRODUCT MANAGER FOR AVAILABILITY

14. BEND DIMENSION AT 1.5mm ONLY

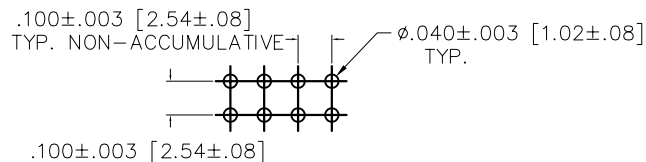

RECOMMENDED HOLE PATTERN

mat'l code	surface	tolerance	projection	product family
NOTES 2 & 3	ISO 1302	ISO 406 ISO 1101		BERGSTIK
ltr	ecn no	dr	date	tolerances unless otherwise specified
BE				linear .XX±.01/XX±.03 linear .XXX±.005/XX±.013 linear .XXXX±.0020/XXX±.0051
				angles 0°±2'
				dr D.WIHTING 03/08/93
				enr T.HANNA 03/08/93
				chr T.BREWNAKER 03/08/93
				appd T.HANNA 03/08/93
sheet	revision			
index	sheet			
				title
				BERGSTIK® II HEADER
				.100/2.54cc DR R/A
				dwg no
				68020
				sheet 2 of 5 size
				A3
				type
				Product Customer Drawing

PRODUCT NUMBER	MATING LENGTH		TAIL LENGTH		BEND DIM.		PIN TO SIDE		BODY WIDTH		PACKAGING	LF OPTION	
	DIM F	DIM F	DIM G	DIM G	DIM H	DIM H	DIM J	DIM J	DIM K	DIM K			
	ENGLISH	METRIC	ENGLISH	METRIC	ENGLISH	METRIC	ENGLISH	METRIC	ENGLISH	METRIC			
68020-YYY	0.230	5.84	0.095	2.41	0.060	1.52	0.045	1.14	0.190	4.83	POLY BAGS	NOTE 1,8	
68021-YYY	0.230	5.84	0.120	3.05	0.060	1.52	0.045	1.14	0.190	4.83	POLY BAGS		
68022-YYY	0.318	8.08	0.110	2.79	0.060	1.52	0.070	1.78	0.240	6.10	POLY BAGS		
68025-YYY	0.230	5.84	0.195	4.95	0.060	1.52	0.045	1.14	0.190	4.83	POLY BAGS		
68405-YYY	0.230	5.84	0.095	2.41	0.060	1.52	0.070	1.78	0.240	6.10	POLY BAGS		
68452-YYY	0.380	9.65	0.110	2.79	0.060	1.52	0.070	1.78	0.240	6.10	POLY BAGS		
68459-YYY	0.318	8.08	0.150	3.81	0.060	1.52	0.070	1.78	0.240	6.10	POLY BAGS/TUBES		
68462-YYY	0.400	10.16	0.120	3.05	0.060	1.52	0.045	1.14	0.190	4.83	POLY BAGS		
68463-YYY	0.230	5.84	0.110	2.79	0.060	1.52	0.070	1.78	0.240	6.10	POLY BAGS		
68480-YYY	0.318	8.08	0.110	2.79	0.060	1.52	0.045	1.14	0.190	4.83	POLY BAGS		
68492-YYY	0.230	5.84	0.150	3.81	0.060	1.52	0.070	1.78	0.240	6.10	POLY BAGS		
68493-YYY													
68695-YYY	0.230	5.84	0.090	2.29	0.060	1.52	0.045	1.14	0.190	4.83	POLY BAGS		
68696-YYY	0.318	8.08	0.125	3.18	0.060	1.52	0.045	1.14	0.190	4.83	POLY BAGS		
68697-YYY	0.230	5.84	0.125	3.18	0.060	1.52	0.045	1.14	0.190	4.83	POLY BAGS		
68715-YYY	0.138	3.51	0.138	3.51	0.060	1.52	0.045	1.14	0.190	4.83	POLY BAGS		
68728-YYY													
68740-YYY	0.345	8.76	0.110	2.79	0.060	1.52	0.070	1.78	0.240	6.10	POLY BAGS		
68759-YYY	0.275	6.99	0.120	3.05	0.060	1.52	0.045	1.14	0.190	4.83	POLY BAGS		
68780-YYY	0.230	5.84	0.039	0.99	0.060	1.52	0.045	1.14	0.190	4.83	POLY BAGS		
69147-YYY	0.540	13.72	0.260	6.60	0.060	1.52	0.045	1.14	0.190	4.83	POLY BAGS		
69186-YYY													
72240-YYYH	0.550	13.97	0.120	3.05	0.060	1.52	0.070	1.78	0.240	6.10	POLY BAGS		
72261-YYYH	0.100	2.54	0.100	2.54	0.060	1.52	0.045	1.14	0.190	4.83	POLY BAGS		
72324-YYYH	0.550	13.97	0.260	6.60	0.060	1.52	0.070	1.78	0.240	6.10	POLY BAGS		
72410-YYYH	0.120	3.05	0.350	8.89	0.120	3.05	0.070	1.78	0.240	6.10	POLY BAGS		
74430-YYYH	0.000	0.00	0.233	5.92	0.060	1.52	0.045	1.14	0.190	4.83	POLY BAGS		



Copyright FCJ

mat'l. code		surface		tolerance		projection		product family	
NOTES 2 & 3		ISO 1302		ISO 406 ISO 1101				BERGSTIK	
ltr	ecn no	dr	date	tolerances unless otherwise specified		INCH/MM		title	
BE				angles	linear	.XX±.01/XX±0.3 .XXX±.005/XX±0.13 .XXXX±.0020/XXX±0.051		BERGSTIK® II HEADER	
				0°±2'		scale 1:1		.100/2.54cc DR R/A	
		dr	D.WIHTING	03/08/93	FCJ		dwg no		sheet 3 of 5 size
		enr	T.HANNA	03/08/93			68020		A3
		chr	T.BREWNAKER	03/08/93			type		Product Customer Drawing
		appd	T.HANNA	03/08/93					
sheet index	revision	sheet							

PRODUCT NUMBER	MATING LENGTH		TAIL LENGTH		BEND DIM.		PIN TO SIDE		BODY WIDTH		PACKAGING	LF OPTION	
	DIM F	DIM F	DIM G	DIM G	DIM H	DIM H	DIM J	DIM J	DIM K	DIM K			
	ENGLISH	METRIC	ENGLISH	METRIC	ENGLISH	METRIC	ENGLISH	METRIC	ENGLISH	METRIC			
78576-YYY	0.120	3.05	0.120	3.05	0.060	1.52	0.070	1.78	0.240	6.10	POLY BAGS	NOTE 1,8	
78923-YYY	0.240	6.10	0.095	2.41	0.060	1.52	0.070	1.78	0.240	6.10	POLY BAGS		
78951-YYY	0.500	12.70	0.120	3.05	0.060	1.52	0.045	1.14	0.190	4.83	POLY BAGS		
79200-YYY	0.155	3.94	0.280	7.11	0.060	1.52	0.070	1.78	0.240	6.10	POLY BAGS		
79201-YYY	0.225	5.72	0.280	7.11	0.060	1.52	0.070	1.78	0.240	6.10	POLY BAGS		
79202-YYY	0.245	6.22	0.280	7.11	0.060	1.52	0.070	1.78	0.240	6.10	POLY BAGS		
79203-YYY	0.315	8.00	0.280	7.11	0.060	1.52	0.070	1.78	0.240	6.10	POLY BAGS		
79204-YYY	0.177	4.50	0.410	10.41	0.060	1.52	0.070	1.78	0.240	6.10	POLY BAGS		
79205-YYY	0.25	6.35	0.410	10.41	0.060	1.52	0.070	1.78	0.240	6.10	POLY BAGS		
79206-YYY	0.315	8.00	0.410	10.41	0.060	1.52	0.070	1.78	0.240	6.10	POLY BAGS		
79248-YYY													
79257-YYY	0.230	5.84	0.120	3.05	0.060	1.52	0.070	1.78	0.240	6.10	POLY BAGS/TUBES		
79258-YYY	0.318	8.08	0.120	3.05	0.060	1.52	0.070	1.78	0.240	6.10	POLY BAGS/TUBES		
79807-YYY													
79841-YYY	0.060	1.52	0.230	5.84	0.060	1.52	0.045	1.14	0.190	4.83	POLY BAGS		
86385-YYY	0.260	6.6	0.120	3.05	0.060	1.52	0.070	1.78	0.240	6.10	POLY BAGS		
86840-YYY	0.318	8.08	0.230	5.84	0.060	1.52	0.070	1.78	0.240	6.10	POLY BAGS		
86867-YYY													
88822-YYY	0.318	8.08	0.080	2.03	0.060	1.52	0.070	1.78	0.240	6.10	POLY BAGS		
89292-YYY	0.120	3.05	0.300	7.62	0.120	3.05	0.045	1.14	0.190	4.83	POLY BAGS		
90234-YYY	0.130	3.30	0.195	4.95	0.060	1.52	0.045	1.14	0.190	4.83	POLY BAGS		
92634-YYY	0.318	8.08	0.318	8.08	0.060	1.52	0.045	1.14	0.190	4.83	POLY BAGS		
93162-YYY	0.230	5.84	0.400	10.16	0.150	3.81	0.045	1.14	0.190	4.83	POLY BAGS		
93932-YYY	0.200	5.08	0.120	3.05	0.060	1.52	0.070	1.78	0.240	6.10	POLY BAGS		
93939-YYY	0.160	4.06	0.120	3.05	0.060	1.52	0.070	1.78	0.240	6.10	POLY BAGS		
94687-XYH	0.430	10.92	0.230	5.84	0.060	1.52	0.045	1.14	0.190	4.83	POLY BAGS		
94688-XYH	0.385	9.78	0.280	7.11	0.060	1.52	0.070	1.78	0.240	6.10	POLY BAGS		



Copyright FCJ

mat'l. code		surface		tolerance		projection		product family	
NOTES 2 & 3		ISO 1302		ISO 406 ISO 1101				BERGSTIK	
ltr	ecr no	dr	date	tolerances unless otherwise specified		INCH/MM		title	
BE				angles	linear			BERGSTIK® II HEADER	
				0°±2'		scale 1:1		.100/2.54cc DR R/A	
				dr	D.WIHTING	03/08/93		dwg no	
				engr	T.HANNA	03/08/93		sheet 4 of 5 size	
				chr	T.BREWNAKER	03/08/93		68020 A3	
				appd	T.HANNA	03/08/93		type	
sheet index		revision sheet						Product Customer Drawing	

PRODUCT NUMBER	MATING LENGTH		TAIL LENGTH		BEND DIM.		PIN TO SIDE		BODY WIDTH		PACKAGING	LF OPTION
	DIM F	DIM F	DIM G	DIM G	DIM H	DIM H	DIM J	DIM J	DIM K	DIM K		
	ENGLISH	METRIC	ENGLISH	METRIC	ENGLISH	METRIC	ENGLISH	METRIC	ENGLISH	METRIC		
95035-YYYH	0.230	5.84	0.400	10.16	0.060	1.52	0.045	1.14	0.190	4.83	POLY BAGS	NOTE 1,8
95182-YYYH	0.400	10.16	0.110	2.79	0.060	1.52	0.070	1.78	0.240	6.10	POLY BAGS	↓ NOTE 1,8
98358-YYYH	0.205	5.21	0.410	10.41	0.060	1.52	0.070	1.78	0.240	6.10	POLY BAGS	
98359-YYYH	0.275	6.99	0.410	10.41	0.060	1.52	0.070	1.78	0.240	6.10	POLY BAGS	



FCJconnect.com

Copyright FCJ

mat'l. code NOTES 2 & 3				surface ISO 1302 <input checked="" type="checkbox"/>		tolerance ISO 406 ISO 1101		projection 		product family BERGSTIK			
ltr	ecn no	dr	date	tolerances unless otherwise specified						title		BERGSTIK® II HEADER	
BE				angles	linear		INCH/MM		.100/2.54cc DR R/A				
				0°±2°	.XX±.01/XX±0.3		scale 1:1		sheet 5 of 5 size		A3		
				dr	D.WIHTING 03/08/93				dwg no		68020		
				enr	T.HANNA 03/08/93				type		Product Customer Drawing		
				chr	T.BREWNAKER 03/08/93								
				appd	T.HANNA 03/08/93								
sheet index	revision sheet												