

# DATA SHEET

## **047 RMS**

Aluminum electrolytic capacitors  
Radial Miniature Semi-Professional

Product specification  
Supersedes data of January 1998  
File under BC Components, BC01

2000 Jan 18

# Aluminum electrolytic capacitors Radial Miniature Semi-Professional

047 RMS

### FEATURES

- Polarized aluminum electrolytic capacitors, non-solid electrolyte
- Radial leads, cylindrical aluminum case with pressure relief, insulated with a blue vinyl sleeve
- Charge and discharge proof
- Long useful life: 1500 hours at 105 °C
- Miniaturized, high CV-product per unit volume.

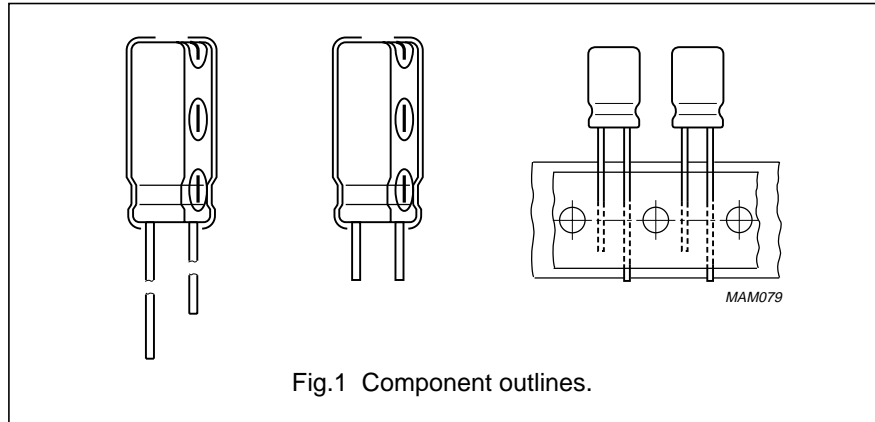
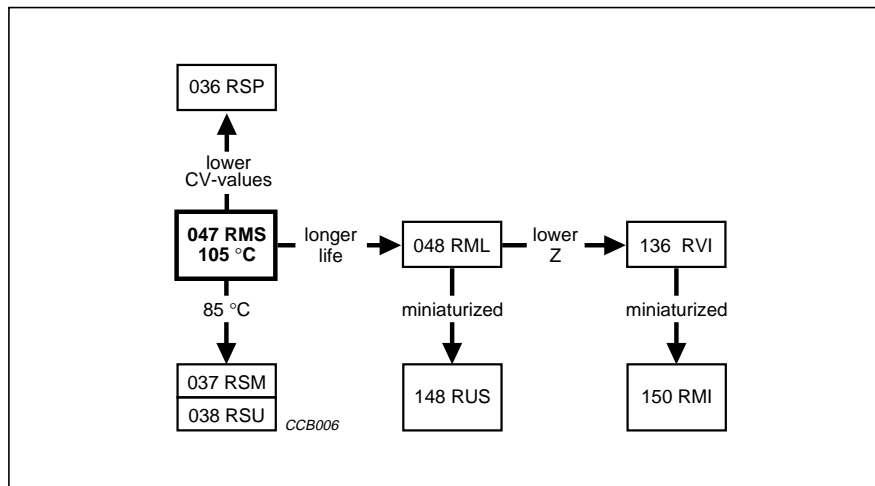

Fig.1 Component outlines.

### APPLICATIONS

- EDB, telecommunication, industrial, automotive and audio-video
- Smoothing, filtering, buffering in SMPS, timing
- Portable and mobile equipment (small size, low mass).



### QUICK REFERENCE DATA

| DESCRIPTION  | VALUE                |
|--|----------------------|
| Case sizes ( $\varnothing D_{nom} \times L_{nom}$ in mm) | 10 × 12 to 18 × 35   |
| Rated capacitance range, $C_R$                           | 100 to 10000 $\mu$ F |
| Tolerance on $C_R$                                       | $\pm 20\%$           |
| Rated voltage range, $U_R$                               | 16 to 63 V           |
| Category temperature range                               | -40 to +105 °C       |
| Endurance test at 105 °C                                 | 1000 hours           |
| Useful life at 105 °C                                    | 1500 hours           |
| Useful life at 40 °C, $1.3 \times I_R$ applied           | 150000 hours         |
| Shelf life at 0 V, 105 °C                                | 500 hours            |
| Based on sectional specification                         | IEC 60384-4/EN130300 |
| Climatic category IEC 60068                              | 40/105/56            |

# Aluminum electrolytic capacitors

## Radial Miniature Semi-Professional

047 RMS

### Selection chart for $C_R$ , $U_R$ and relevant nominal case sizes ( $\varnothing D \times L$ in mm)

Preferred types in **bold**.

| $C_R$<br>( $\mu F$ ) | $U_R$ (V) |                  |                |                |                  |                  |
|----------------------|-----------|------------------|----------------|----------------|------------------|------------------|
|                      | 16        | 25               | 35             | 40             | 50               | 63               |
| 100 <sup>(1)</sup>   | –         | –                | –              | –              | –                | <b>10 × 12</b>   |
| 220                  | –         | –                | <b>10 × 12</b> | –              | 10 × 16          | <b>10 × 20</b>   |
| 330                  | –         | –                | 10 × 16        | 10 × 20        | –                | 12.5 × 20        |
| 470                  | 10 × 12   | <b>10 × 16</b>   | 10 × 20        | –              | <b>12.5 × 20</b> | <b>12.5 × 25</b> |
| 1000                 | 10 × 20   | <b>12.5 × 20</b> | 12.5 × 25      | –              | <b>16 × 25</b>   | 16 × 31          |
| 2200                 | 12.5 × 25 | <b>16 × 25</b>   | 16 × 31        | <b>16 × 35</b> | 18 × 35          | <b>18 × 35</b>   |
| 3300                 | 16 × 25   | 16 × 31          | 18 × 35        | <b>18 × 35</b> | 18 × 35          | –                |
| 4700                 | 16 × 31   | 18 × 35          | 18 × 35        | –              | –                | –                |
| 6800                 | 16 × 35   | 18 × 35          | –              | –              | –                | –                |
| 10000                | 18 × 35   | –                | –              | –              | –                | –                |

#### Note

1. For lower CV-values see data sheet "036 RSP".

Aluminum electrolytic capacitors  
Radial Miniature Semi-Professional

047 RMS

MECHANICAL DATA, AVAILABLE FORMS AND PACKAGING QUANTITIES

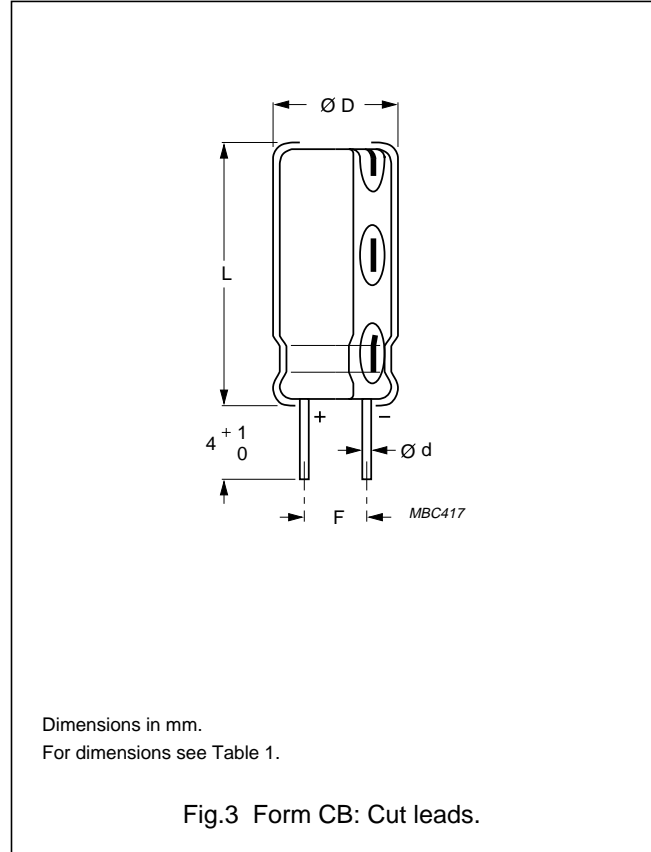
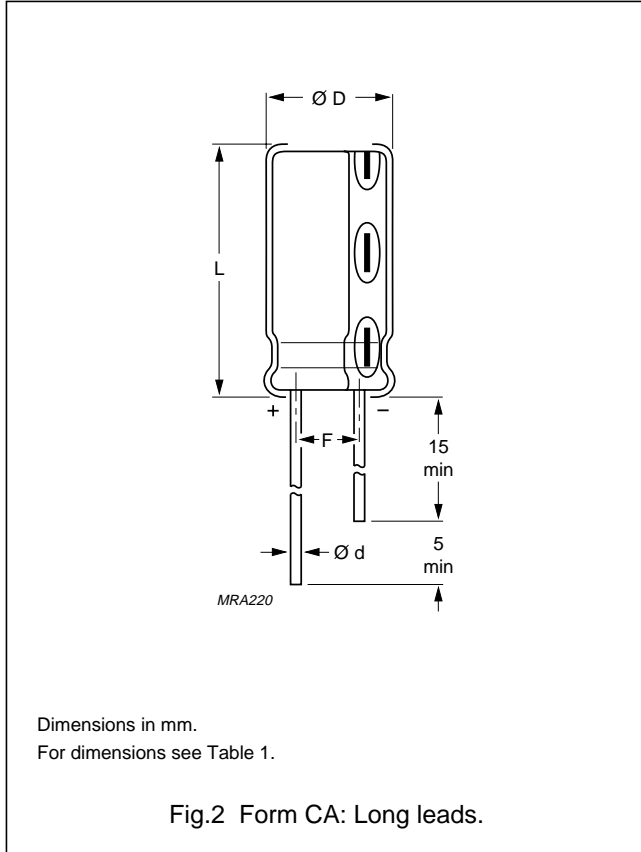

Table 1 Physical dimensions, mass and packaging quantities; see Figs 2 and 3

| NOMINAL CASE SIZE<br>ØD × L<br>(mm) | CASE CODE | Ød (mm) | ØD <sub>max</sub> (mm) | L <sub>max</sub> (mm) | F (mm)   | MASS (g) | PACKAGING QUANTITIES |                 |                  |
|-------------------------------------|-----------|---------|------------------------|-----------------------|----------|----------|----------------------|-----------------|------------------|
|                                     |           |         |                        |                       |          |          | FORM CA per box      | FORM CB per box | FORM TFA per box |
| 10 × 12                             | 14        | 0.6     | 10.5                   | 13.5                  | 5.0 ±0.5 | ≈1.6     | 1000                 | 500             | 800              |
| 10 × 16                             | 15        | 0.6     | 10.5                   | 17.5                  | 5.0 ±0.5 | ≈1.9     | 500                  | 500             | 800              |
| 10 × 20                             | 16        | 0.6     | 10.5                   | 22.0                  | 5.0 ±0.5 | ≈2.2     | 500                  | 500             | 800              |
| 12.5 × 20                           | 17        | 0.6     | 13.0                   | 22.0                  | 5.0 ±0.5 | ≈4.0     | 500                  | 500             | 500              |
| 12.5 × 25                           | 18        | 0.6     | 13.0                   | 27.0                  | 5.0 ±0.5 | ≈5.0     | 250                  | 250             | 500              |
| 16 × 25                             | 19        | 0.8     | 16.5                   | 27.0                  | 7.5 ±0.5 | ≈8.0     | 250                  | 250             | 250              |
| 16 × 31                             | 20        | 0.8     | 16.5                   | 33.5                  | 7.5 ±0.5 | ≈9.0     | 100                  | 100             | 250              |
| 16 × 35                             | 21        | 0.8     | 16.5                   | 37.5                  | 7.5 ±0.5 | ≈11.5    | 100                  | 100             | –                |
| 18 × 35                             | 22        | 0.8     | 18.5                   | 37.5                  | 7.5 ±0.5 | ≈14.5    | 100                  | 100             | –                |

# Aluminum electrolytic capacitors

## Radial Miniature Semi-Professional

047 RMS

### Taped products

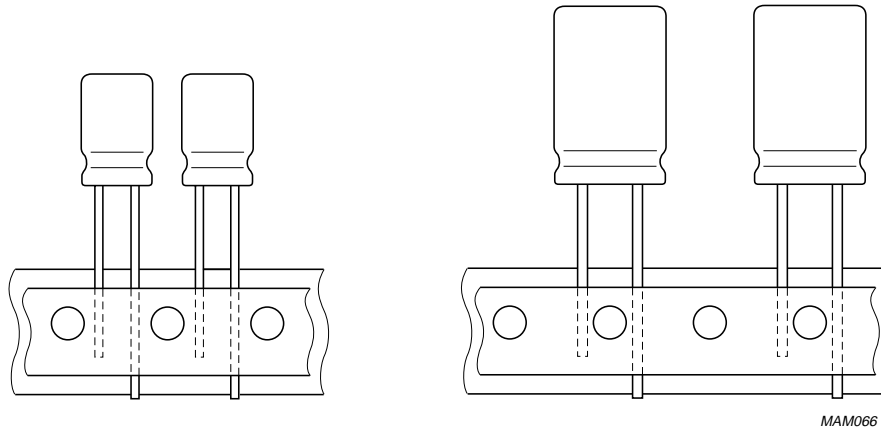
**Form TFA:****Case  $\varnothing D \times L \leq 16 \times 31$  mm.**

Tape dimensions are specified in this handbook, section "Packaging".

Fig.4 Taped in box (ammopack).

### MARKING

The capacitors are marked with the following information:

- Rated capacitance value (in  $\mu\text{F}$ )
- Tolerance on rated capacitance, code letter in accordance with "IEC 60062" (M for  $\pm 20\%$ )
- Rated voltage (in V)
- Upper category temperature (105 °C)
- Group number (047)
- Code indicating factory of origin
- Name of manufacturer
- Date code, in accordance with "IEC 60062"
- Negative terminal identification.

Aluminum electrolytic capacitors  
Radial Miniature Semi-Professional

047 RMS

**Ordering example**

Electrolytic capacitor 047 series  
1000 µF/35 V; ±20  
Nominal case size: Ø12.5 × 25 mm; Form TFA  
Catalogue number: 2222 047 30102.

**ELECTRICAL DATA AND ORDERING INFORMATION**

Unless otherwise specified, all electrical values in Table 2 apply at T<sub>amb</sub> = 20 °C, P = 86 to 106 kPa, RH = 45 to 75%.

| SYMBOL          | DESCRIPTION   |
|-----------------|---|
| C <sub>R</sub>  | rated capacitance at 100 Hz, tolerance ±20%   |
| I <sub>R</sub>  | rated RMS ripple current at 100 Hz, 105 °C  |
| I <sub>L1</sub> | max. leakage current after 1 minute at U <sub>R</sub>   |
| I <sub>L5</sub> | max. leakage current after 5 minutes at U <sub>R</sub>  |
| Tan δ           | max. dissipation factor at 100 Hz   |
| ESR             | equivalent series resistance at 100 Hz (calculated from tan δ <sub>max</sub> and C <sub>R</sub> ) |
| Z               | max. impedance at 10 kHz or 100 kHz   |

**Table 2** Electrical data and ordering information; preferred types in **bold**

| U <sub>R</sub><br>(V) | C <sub>R</sub><br>100 Hz<br>(µF) | NOMINAL<br>CASE SIZE<br>ØD × L<br>(mm) | CASE<br>CODE | I <sub>R</sub><br>100 Hz<br>105 °C<br>(mA) | I <sub>L1</sub><br>1 min<br>(µA) | I <sub>L5</sub><br>5 min<br>(µA) | Tan δ<br>100 Hz | ESR<br>100 Hz<br>(Ω) | Z<br>10 kHz<br>(Ω) | Z<br>100 kHz<br>(Ω) | CATALOGUE NUMBER 2222 ... .. |                  |                  |
|-----------------------|----------------------------------|--|--------------|--|----------------------------------|----------------------------------|-----------------|----------------------|--------------------|---------------------|------------------------------|------------------|------------------|
|                       |                                  |  |              |  |                                  |                                  |                 |                      |                    |                     | BULK PACKAGING               |                  | TAPED            |
|                       |                                  |  |              |  |                                  |                                  |                 |                      |                    |                     | FORM CA                      | FORM CB          | FORM TFA         |
| 16                    | 470                              | 10 × 12                                | 14           | 330  | 78                               | 18                               | 0.16            | 0.51                 | 0.45               | 0.33                | 047 55471                    | 047 65471        | 047 35471        |
|                       | 1000                             | 10 × 20                                | 16           | 540  | 160                              | 35                               | 0.16            | 0.24                 | 0.21               | 0.17                | 047 55102                    | 047 65102        | 047 35102        |
|                       | 2200                             | 12.5 × 25                              | 18           | 830  | 360                              | 73                               | 0.20            | 0.14                 | 0.12               | 0.10                | 047 55222                    | 047 65222        | 047 35222        |
|                       | 3300                             | 16 × 25                                | 19           | 1100                                       | 530                              | 110                              | 0.22            | 0.10                 | 0.09               | 0.08                | 047 55332                    | 047 65332        | 047 35332        |
|                       | 4700                             | 16 × 31                                | 20           | 1300                                       | 760                              | 150                              | 0.24            | 0.08                 | 0.07               | 0.07                | 047 55472                    | 047 65472        | 047 35472        |
|                       | 6800                             | 16 × 35                                | 21           | 1600                                       | 1100                             | 220                              | 0.28            | 0.06                 | 0.06               | 0.06                | 047 55682                    | 047 65682        | -                |
|                       | 10000                            | 18 × 35                                | 22           | 1800                                       | 1600                             | 320                              | 0.36            | 0.05                 | 0.05               | 0.05                | 047 55103                    | 047 65103        | -                |
| 25                    | <b>470</b>                       | <b>10 × 16</b>                         | <b>15</b>    | 360  | 120                              | 27                               | 0.14            | 0.45                 | 0.38               | 0.25                | 047 56471                    | <b>047 66471</b> | <b>047 36471</b> |
|                       | <b>1000</b>                      | <b>12.5 × 20</b>                       | <b>17</b>    | 630  | 250                              | 53                               | 0.14            | 0.21                 | 0.18               | 0.13                | 047 56102                    | <b>047 66102</b> | <b>047 36102</b> |
|                       | <b>2200</b>                      | <b>16 × 25</b>                         | <b>19</b>    | 990  | 550                              | 110                              | 0.18            | 0.12                 | 0.09               | 0.08                | 047 56222                    | <b>047 66222</b> | <b>047 36222</b> |
|                       | 3300                             | 16 × 31                                | 20           | 1200                                       | 830                              | 170                              | 0.20            | 0.09                 | 0.07               | 0.07                | 047 56332                    | 047 66332        | 047 36332        |
|                       | 4700                             | 18 × 35                                | 22           | 1500                                       | 1200                             | 240                              | 0.22            | 0.07                 | 0.05               | 0.05                | 047 56472                    | 047 66472        | -                |
|                       | 6800                             | 18 × 35                                | 22           | 1700                                       | 1700                             | 340                              | 0.26            | 0.06                 | 0.04               | 0.04                | 047 56682                    | 047 66682        | -                |

# Aluminum electrolytic capacitors

## Radial Miniature Semi-Professional

047 RMS

| U <sub>R</sub><br>(V) | C <sub>R</sub><br>100 Hz<br>(μF) | NOMINAL<br>CASE SIZE<br>∅D × L<br>(mm) | CASE<br>CODE | I <sub>R</sub><br>100 Hz<br>105 °C<br>(mA) | I <sub>L1</sub><br>1 min<br>(μA) | I <sub>L5</sub><br>5 min<br>(μA) | Tan δ<br>100 Hz | ESR<br>100 Hz<br>(Ω) | Z<br>10 kHz<br>(Ω) | Z<br>100 kHz<br>(Ω) | CATALOGUE NUMBER 2222 ... .. |           |           |
|-----------------------|----------------------------------|--|--------------|--|----------------------------------|----------------------------------|-----------------|----------------------|--------------------|---------------------|------------------------------|-----------|-----------|
|                       |                                  |  |              |  |                                  |                                  |                 |                      |                    |                     | BULK PACKAGING               |           | TAPED     |
|                       |                                  |  |              |  |                                  |                                  |                 |                      |                    |                     | FORM CA                      | FORM CB   |           |
| 35                    | 220                              | 10 × 12                                | 14           | 270  | 80                               | 18                               | 0.12            | 0.83                 | 0.57               | 0.38                | 047 50221                    | 047 60221 | 047 30221 |
|                       | 330                              | 10 × 16                                | 15           | 350  | 120                              | 26                               | 0.12            | 0.55                 | 0.38               | 0.28                | 047 50331                    | 047 60331 | 047 30331 |
|                       | 470                              | 10 × 20                                | 16           | 450  | 170                              | 36                               | 0.12            | 0.39                 | 0.27               | 0.22                | 047 50471                    | 047 60471 | 047 30471 |
|                       | 1000                             | 12.5 × 25                              | 18           | 780  | 350                              | 73                               | 0.12            | 0.18                 | 0.13               | 0.12                | 047 50102                    | 047 60102 | 047 30102 |
|                       | 2200                             | 16 × 31                                | 20           | 1200                                       | 770                              | 160                              | 0.16            | 0.11                 | 0.07               | 0.07                | 047 50222                    | 047 60222 | 047 30222 |
|                       | 3300                             | 18 × 35                                | 22           | 1500                                       | 1200                             | 230                              | 0.18            | 0.09                 | 0.05               | 0.05                | 047 50332                    | 047 60332 | –         |
| 40                    | 4700                             | 18 × 35                                | 22           | 1800                                       | 1600                             | 330                              | 0.20            | 0.06                 | 0.04               | 0.04                | 047 50472                    | 047 60472 | –         |
|                       | 330                              | 10 × 20                                | 16           | 380  | 140                              | 29                               | 0.12            | 0.55                 | 0.33               | 0.26                | 047 57331                    | 047 67331 | 047 37331 |
|                       | 2200                             | 16 × 35                                | 21           | 1200                                       | 880                              | 180                              | 0.16            | 0.11                 | 0.06               | 0.06                | 047 57222                    | 047 67222 | –         |
| 50                    | 3300                             | 18 × 35                                | 22           | 1500                                       | 1300                             | 270                              | 0.18            | 0.08                 | 0.04               | 0.04                | 047 57332                    | 047 67332 | –         |
|                       | 220                              | 10 × 16                                | 15           | 310  | 110                              | 25                               | 0.10            | 0.69                 | 0.43               | 0.33                | 047 51221                    | 047 61221 | 047 31221 |
|                       | 470                              | 12.5 × 20                              | 17           | 540  | 240                              | 50                               | 0.10            | 0.32                 | 0.20               | 0.17                | 047 51471                    | 047 61471 | 047 31471 |
|                       | 1000                             | 16 × 25                                | 19           | 940  | 500                              | 100                              | 0.10            | 0.15                 | 0.10               | 0.09                | 047 51102                    | 047 61102 | 047 31102 |
|                       | 2200                             | 18 × 35                                | 22           | 1400                                       | 1100                             | 220                              | 0.14            | 0.10                 | 0.05               | 0.05                | 047 51222                    | 047 61222 | –         |
| 63                    | 3300                             | 18 × 35                                | 22           | 1600                                       | 1700                             | 330                              | 0.16            | 0.07                 | 0.03               | 0.04                | 047 51332                    | 047 61332 | –         |
|                       | 100                              | 10 × 12                                | 14           | 210  | 66                               | 16                               | 0.09            | 1.40                 | 0.75               | 0.65                | 047 58101                    | 047 68101 | 047 38101 |
|                       | 220                              | 10 × 20                                | 16           | 350  | 140                              | 31                               | 0.09            | 0.62                 | 0.34               | 0.32                | 047 58221                    | 047 68221 | 047 38221 |
|                       | 330                              | 12.5 × 20                              | 17           | 470  | 210                              | 45                               | 0.09            | 0.41                 | 0.23               | 0.22                | 047 58331                    | 047 68331 | 047 38331 |
|                       | 470                              | 12.5 × 25                              | 18           | 620  | 300                              | 62                               | 0.09            | 0.29                 | 0.16               | 0.16                | 047 58471                    | 047 68471 | 047 38471 |
|                       | 1000                             | 16 × 31                                | 20           | 1100                                       | 630                              | 130                              | 0.09            | 0.14                 | 0.08               | 0.08                | 047 58102                    | 047 68102 | 047 38102 |
| 2200                  | 18 × 35                          | 22                                     | 1500         | 1400                                       | 280                              | 0.13                             | 0.09            | 0.04                 | 0.04               | 047 58222           | 047 68222                    | –         |           |

Aluminum electrolytic capacitors  
Radial Miniature Semi-Professional

047 RMS

## Additional electrical data

| DESCRIPTION                        | CONDITIONS                                | VALUE  |
|------------------------------------|---|--|
| <b>Voltage</b>                     |   |  |
| Surge voltage                      |   | $U_s \leq 1.15 U_R$                          |
| Reverse voltage                    |   | $U_{rev} \leq 1 V$                           |
| <b>Current</b>                     |   |  |
| Leakage current                    | after 1 minute at $U_R$                   | $I_{L1} \leq 0.01 C_R \times U_R + 3 \mu A$  |
|                                    | after 5 minutes at $U_R$                  | $I_{L5} \leq 0.002 C_R \times U_R + 3 \mu A$ |
| <b>Inductance</b>                  |   |  |
| Equivalent series inductance (ESL) | case $\varnothing D = 10 \text{ mm}$      | typ. 16 nH                                   |
|                                    | case $\varnothing D \geq 12.5 \text{ mm}$ | typ. 18 nH                                   |



Aluminum electrolytic capacitors  
Radial Miniature Semi-Professional

047 RMS

Capacitance (C)

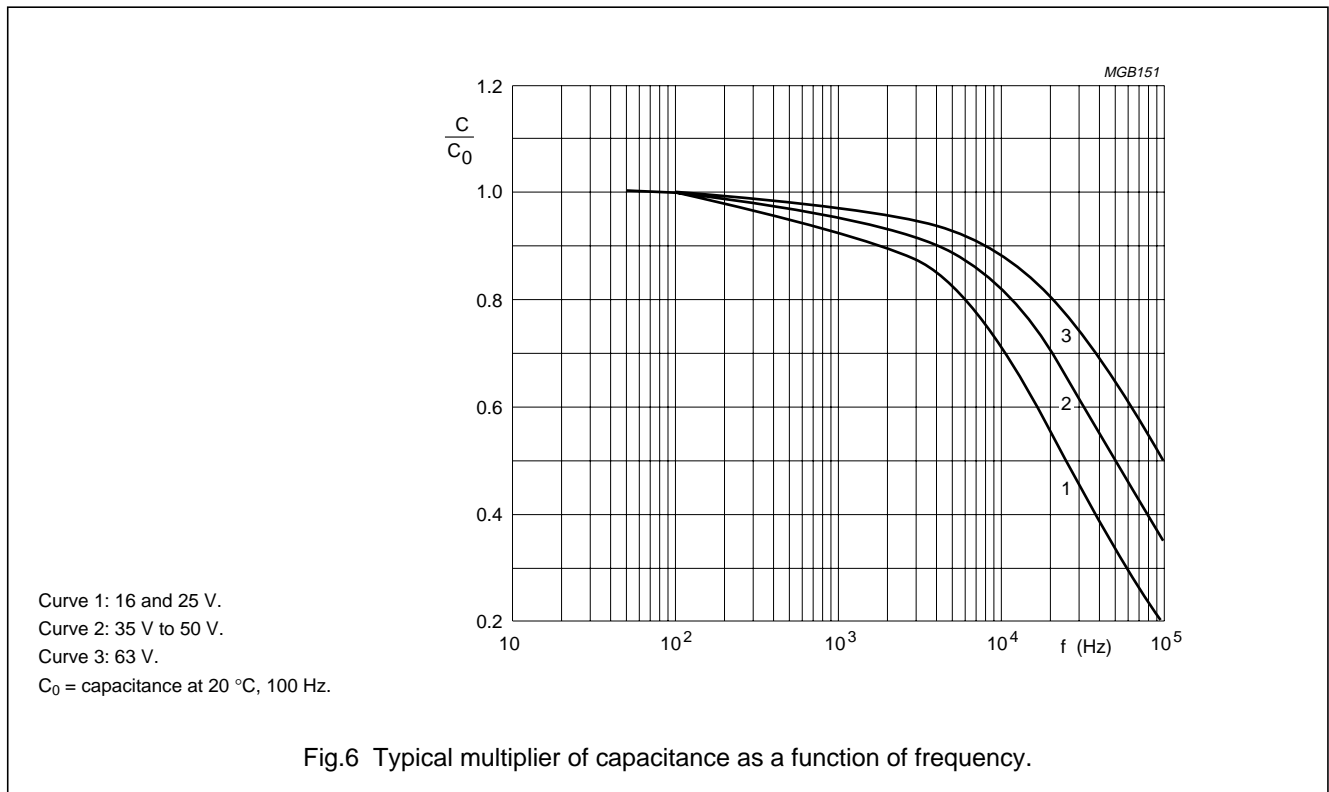
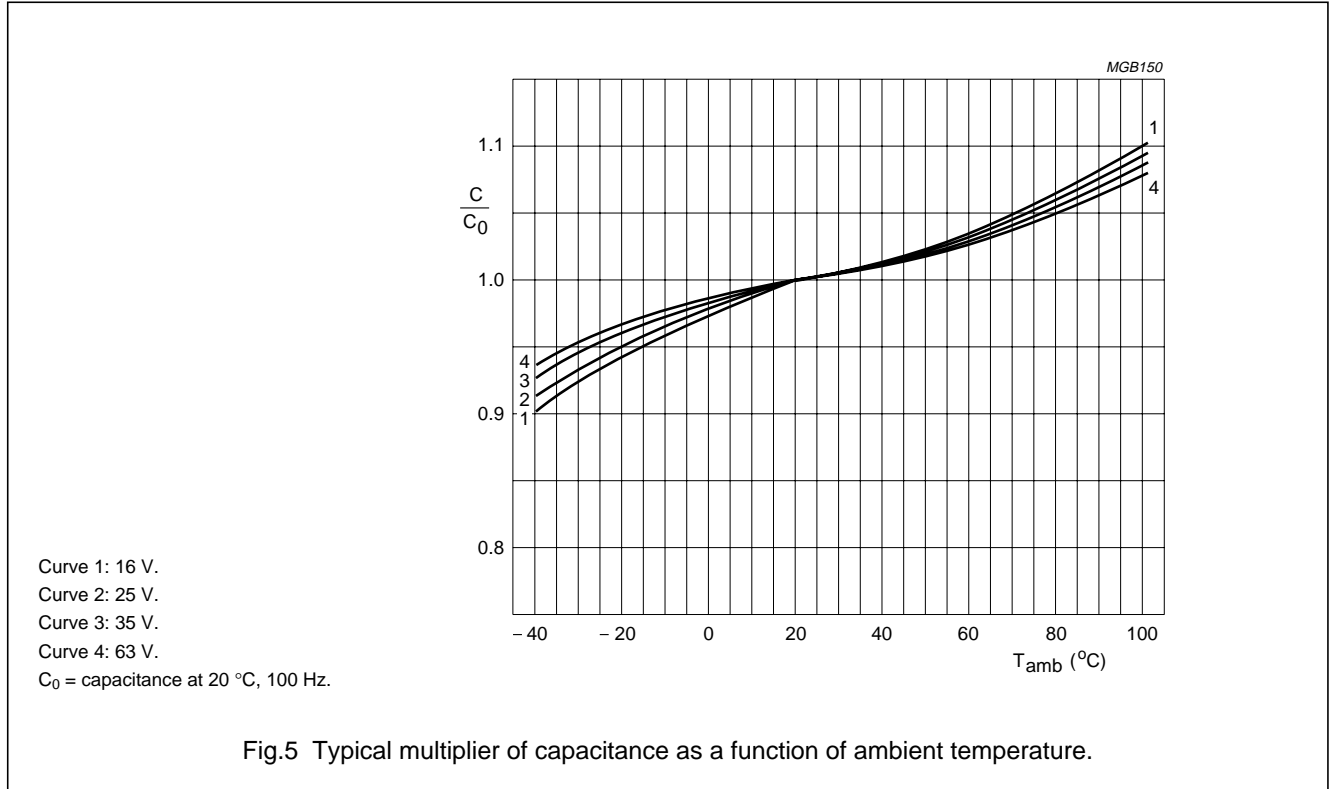

Aluminum electrolytic capacitors  
Radial Miniature Semi-Professional

047 RMS

Equivalent series resistance (ESR)

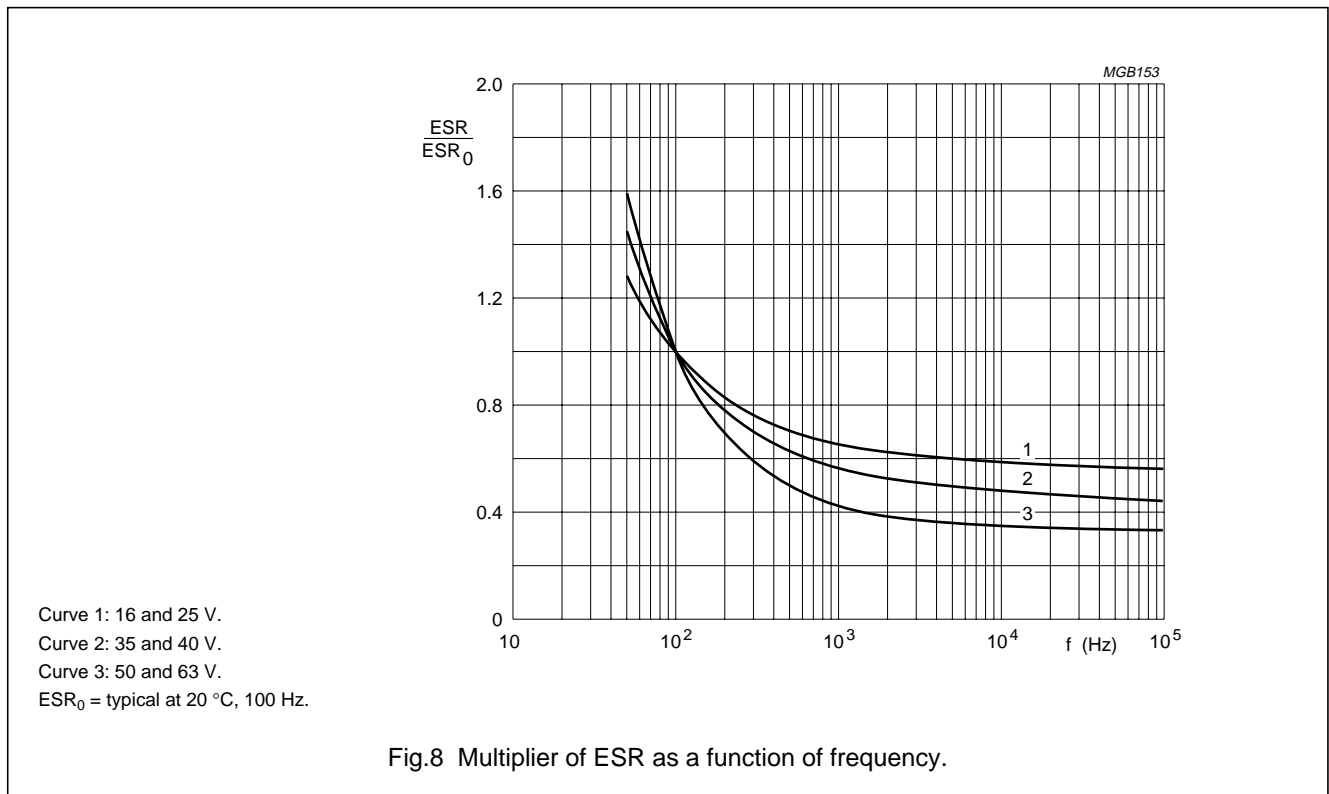
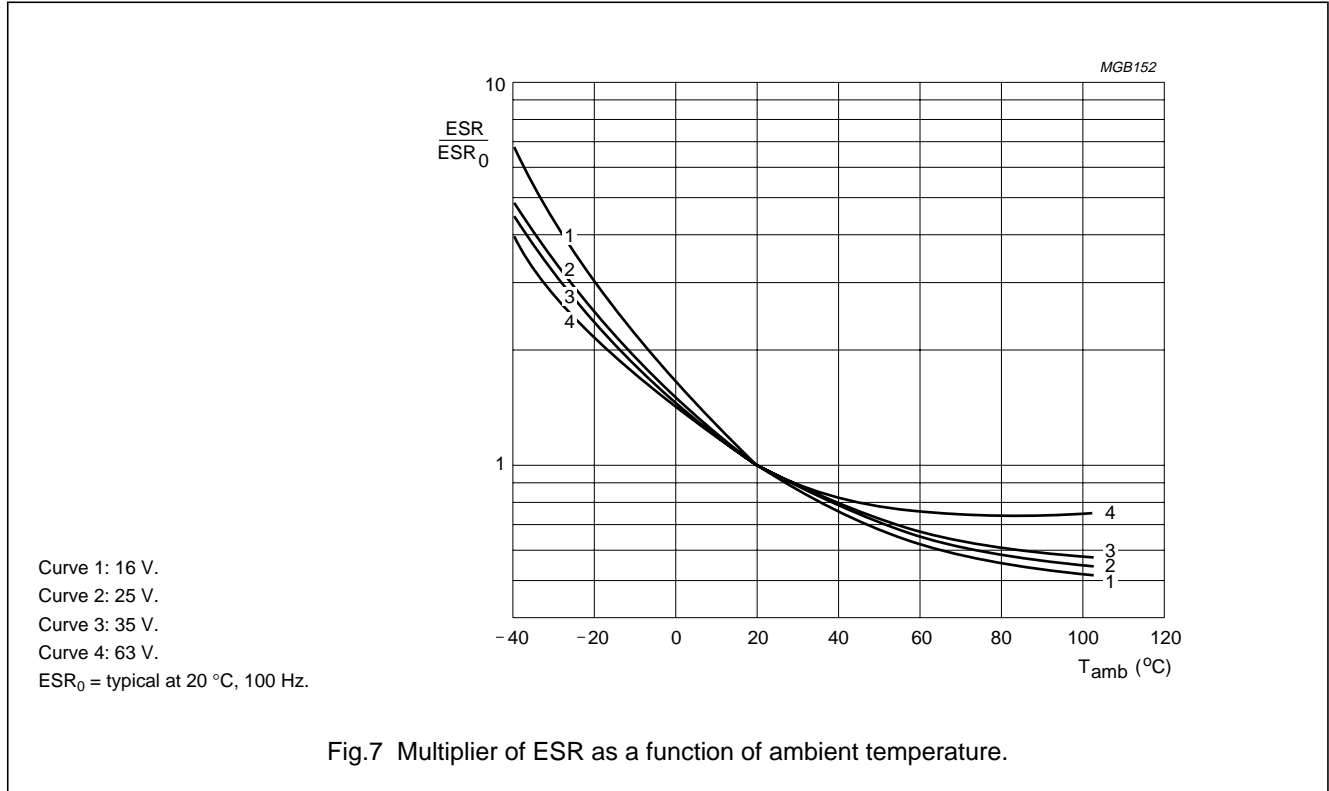

# Aluminum electrolytic capacitors Radial Miniature Semi-Professional

047 RMS

## Impedance (Z)

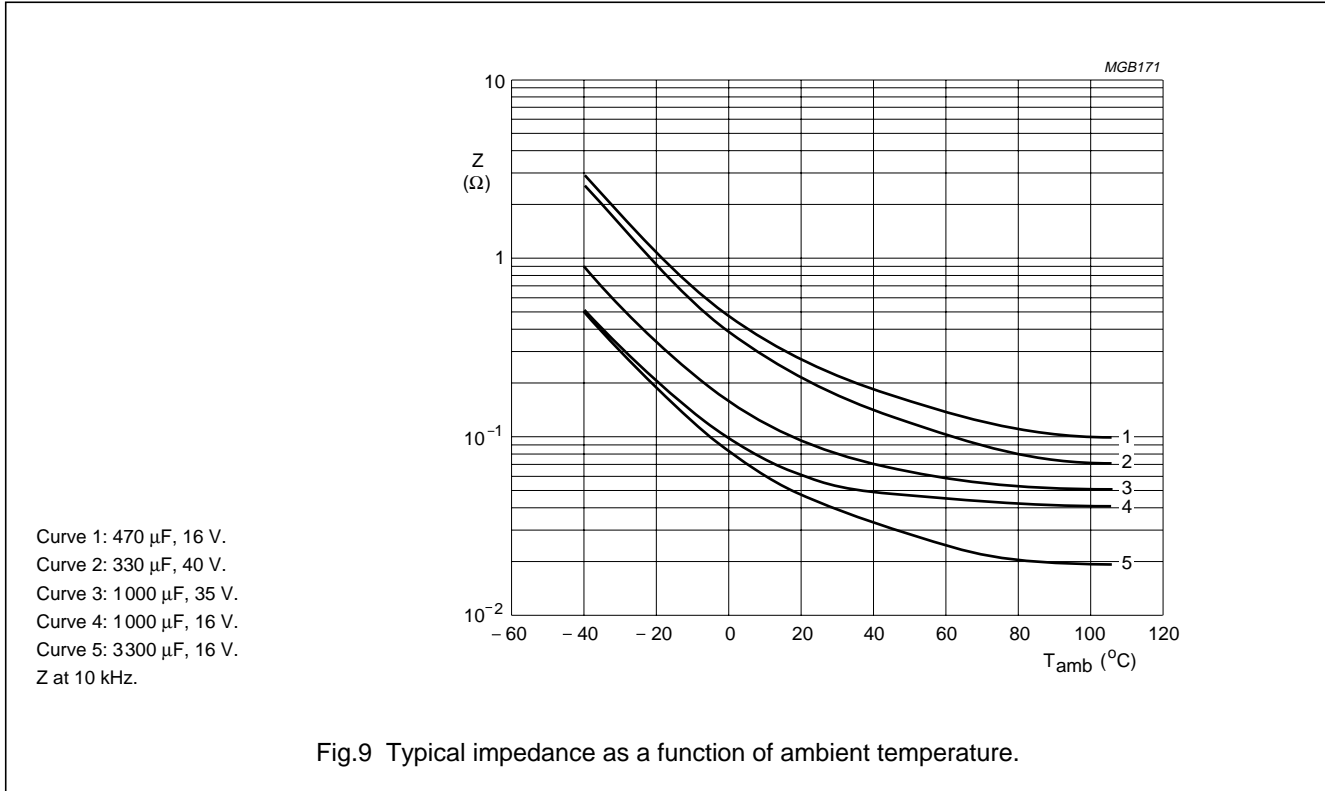

Fig.9 Typical impedance as a function of ambient temperature.

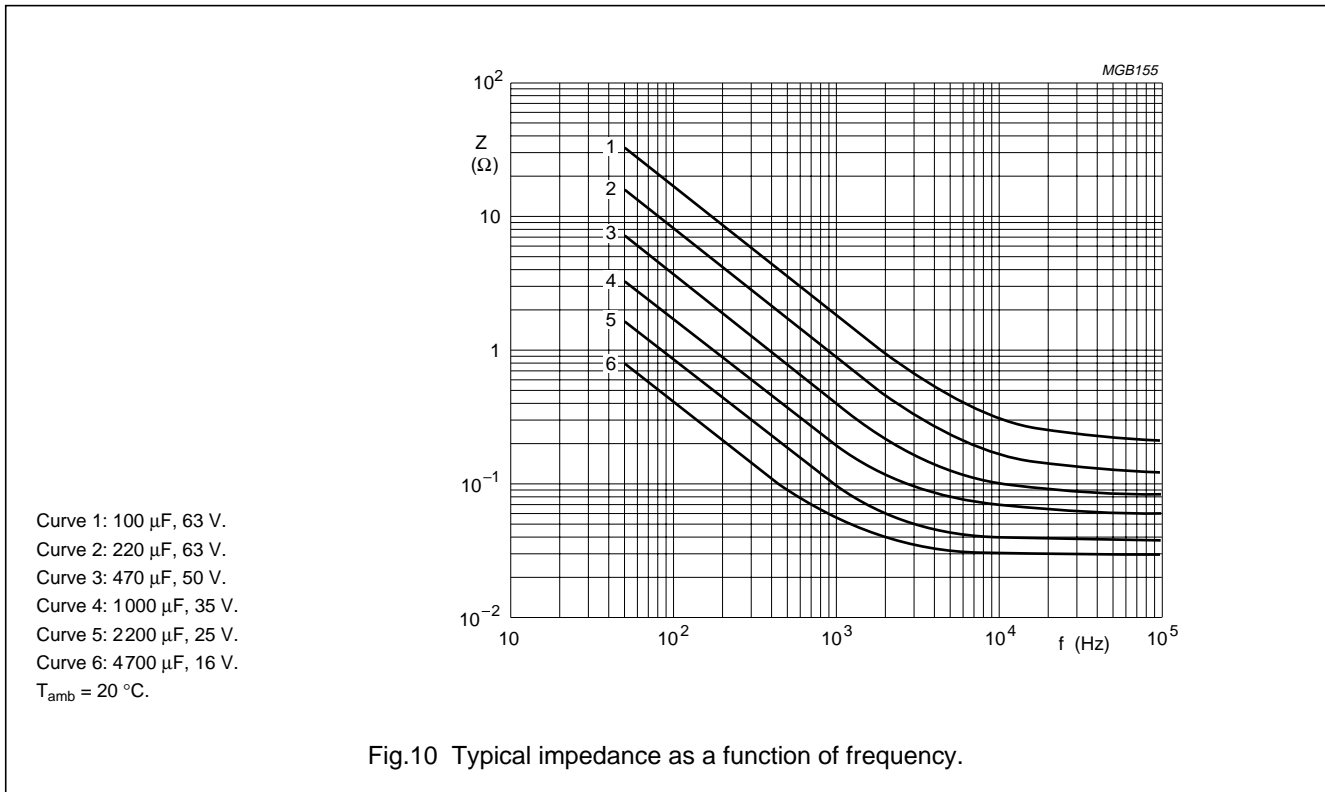

Fig.10 Typical impedance as a function of frequency.

Aluminum electrolytic capacitors  
Radial Miniature Semi-Professional

047 RMS

RIPPLE CURRENT AND USEFUL LIFE

Table 3 Multiplier of ripple current ( $I_R$ ) as a function of frequency

| FREQUENCY<br>(Hz) | $I_R$ MULTIPLIER      |                       |                       |
|-------------------|-----------------------|-----------------------|-----------------------|
|                   | $U_R = 16$ and $25$ V | $U_R = 35$ and $40$ V | $U_R = 50$ and $63$ V |
| 50                | 0.95                  | 0.85                  | 0.80                  |
| 100               | 1.00                  | 1.00                  | 1.00                  |
| 300               | 1.07                  | 1.20                  | 1.25                  |
| 1000              | 1.12                  | 1.30                  | 1.40                  |
| 3000              | 1.15                  | 1.35                  | 1.50                  |
| $\geq 10000$      | 1.20                  | 1.40                  | 1.60                  |

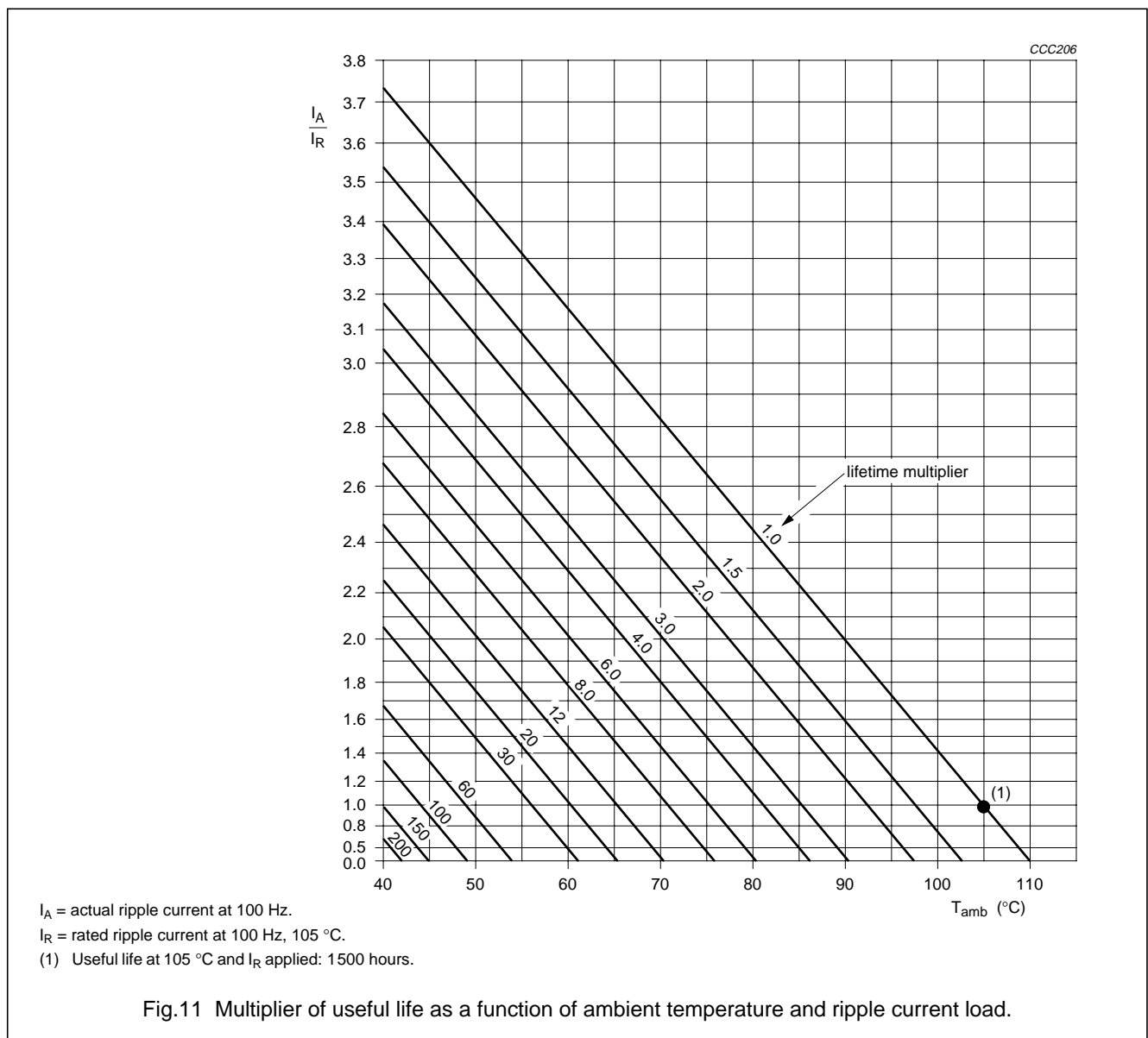

# Aluminum electrolytic capacitors

## Radial Miniature Semi-Professional

047 RMS

### SPECIFIC TESTS AND REQUIREMENTS

General tests and requirements are specified in this handbook, section "Tests and Requirements".

**Table 4** Test procedures and requirements

| TEST   |   | PROCEDURE<br>(quick reference)   | REQUIREMENTS   |
|--|---|--|--|
| NAME OF TEST                                   | REFERENCE                                   |  |  |
| Endurance                                      | IEC 60384-4/<br>EN130300<br>subclause 4.13  | $T_{amb} = 105\text{ °C}$ ; $U_R$ applied;<br>1000 hours   | $\Delta C/C: \pm 15\%$<br>$\tan \delta \leq 1.3 \times \text{spec. limit}$<br>$Z \leq 2 \times \text{spec. limit}$<br>$I_{L5} \leq \text{spec. limit}$   |
| Useful life                                    | CECC 30301<br>subclause 1.8.1               | $T_{amb} = 105\text{ °C}$ ; $U_R$ and $I_R$ applied;<br>1500 hours   | $\Delta C/C: \pm 45\%$<br>$\tan \delta \leq 3 \times \text{spec. limit}$<br>$Z \leq 3 \times \text{spec. limit}$<br>$I_{L5} \leq \text{spec. limit}$<br>no short or open circuit<br>total failure percentage: $\leq 1\%$ |
| Shelf life<br>(storage at high<br>temperature) | IEC 60384-4/<br>EN130300,<br>subclause 4.17 | $T_{amb} = 105\text{ °C}$ ; no voltage applied;<br>500 hours<br><br>after test: $U_R$ to be applied for 30 minutes,<br>24 to 48 hours before measurement | $\Delta C/C: \pm 15\%$<br>$\tan \delta \leq 1.3 \times \text{spec. limit}$<br>$Z \leq 2 \times \text{spec. limit}$<br>$I_{L5} \leq 2 \times \text{spec. limit}$  |