

## Silicon PNP Power Transistors

## 2SA679 2SA680

## DESCRIPTION

- With TO-3 package
- Complement to type 2SC1079/1080
- High power dissipation

## APPLICATIONS

- For audio power amplifier applications

## PINNING(see Fig.2)

PIN	DESCRIPTION
1	Base
2	Emitter
3	Collector

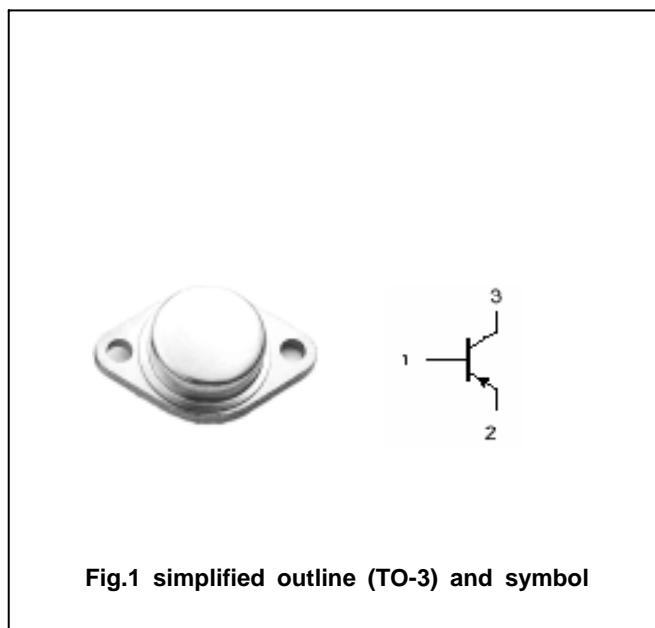

Fig.1 simplified outline (TO-3) and symbol

Absolute maximum ratings( $T_a = \text{---}$ )

SYMBOL	PARAMETER	CONDITIONS	VALUE	UNIT
$V_{CBO}$	Collector-base voltage	2SA679	-120	V
		2SA680	-100	
$V_{CEO}$	Collector-emitter voltage	2SA679	-120	V
		2SA680	-100	
$V_{EBO}$	Emitter-base voltage	Open collector	-5	V
$I_C$	Collector current		-12	A
$I_E$	Emitter current		12	A
$P_C$	Collector power dissipation	$T_C=25$	100	W
$T_j$	Junction temperature		150	
$T_{stg}$	Storage temperature		-65~150	

## Silicon PNP Power Transistors

## 2SA679 2SA680

## CHARACTERISTICS

T<sub>j</sub>=25 unless otherwise specified

SYMBOL	PARAMETER	CONDITIONS	MIN	TYP.	MAX	UNIT
V <sub>(BR)CEO</sub>	Collector-emitter breakdown voltage	2SA679	I <sub>C</sub> =-0.1A ; I <sub>B</sub> =0	-120		V
		2SA680		-100		
V <sub>(BR)EBO</sub>	Emitter-base breakdown voltage	I <sub>E</sub> =-10mA ; I <sub>C</sub> =0	-5			V
V <sub>CEsat</sub>	Collector-emitter saturation voltage	I <sub>C</sub> =-10A ; I <sub>B</sub> =-1A			-3.0	V
V <sub>BE</sub>	Base-emitter on voltage	I <sub>C</sub> =-10A ; V <sub>CE</sub> =-5V			-2.5	V
I <sub>CBO</sub>	Collector cut-off current	V <sub>CB</sub> =-50V ; I <sub>E</sub> =0			-0.1	mA
I <sub>EBO</sub>	Emitter cut-off current	V <sub>EB</sub> =-5V ; I <sub>C</sub> =0			-0.1	mA
h <sub>FE-1</sub>	DC current gain	I <sub>C</sub> =-2A ; V <sub>CE</sub> =-5V	40		140	
h <sub>FE-2</sub>	DC current gain	I <sub>C</sub> =-7A ; V <sub>CE</sub> =-5V	15			
C <sub>OB</sub>	Output capacitance	I <sub>E</sub> =0 ; V <sub>CB</sub> =-10V ; f=1.0MHz		900		pF
f <sub>T</sub>	Transition frequency	I <sub>C</sub> =-2A ; V <sub>CE</sub> =-5V		6		MHz

◆ h<sub>FE-1</sub> Classifications

R	Y
40-80	70-140

PACKAGE OUTLINE

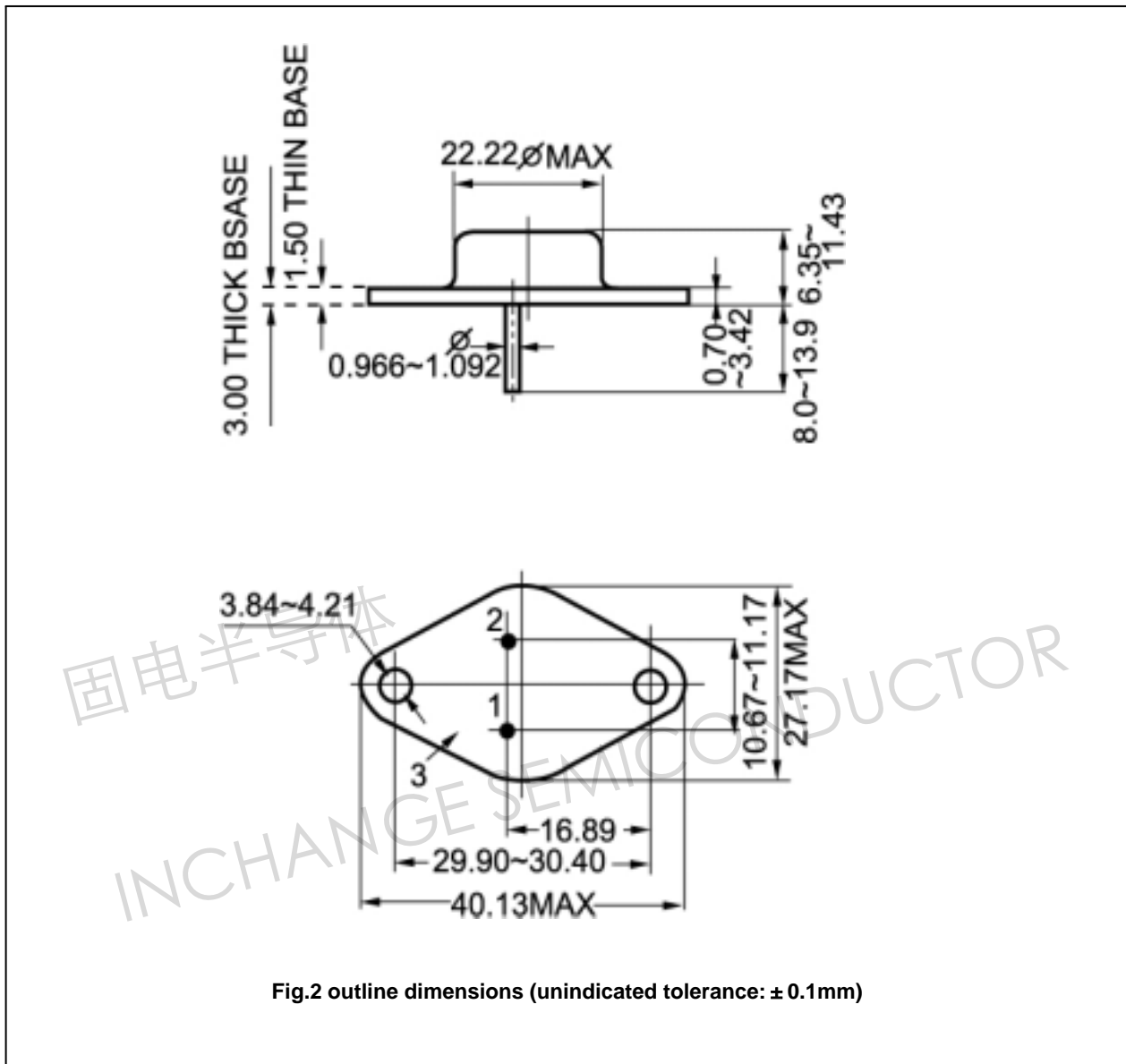

Fig.2 outline dimensions (unindicated tolerance:  $\pm 0.1$ mm)