

AP1117

1A Positive Low Dropout Regulator

■ Features

- 1.3V Maximum Dropout at Full Load Current
- Fast Transient Response.
- Output Current Limiting
- Built-in Thermal Shutdown
- Package: SOT223-3L, TO252-3L, TO220-3L
- Flexible Output voltage setting 0.1V Step in the range of 1.3V to 5V
- Good noise rejection

■ Applications

- PC peripheral
- Communication

■ Ordering Information

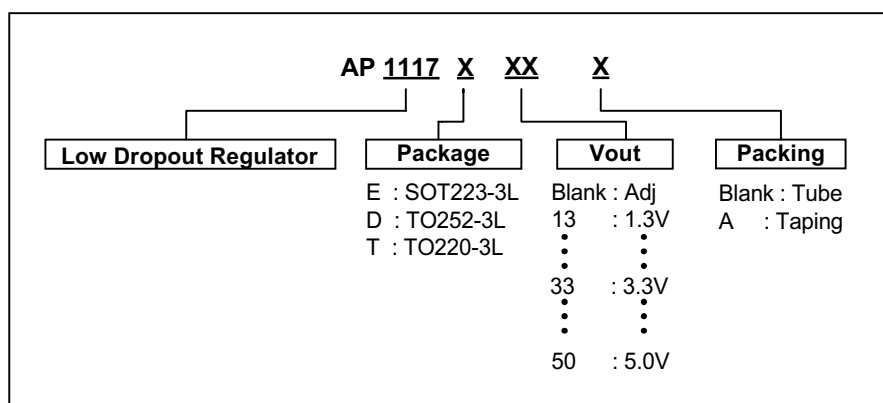

■ Typical Circuit

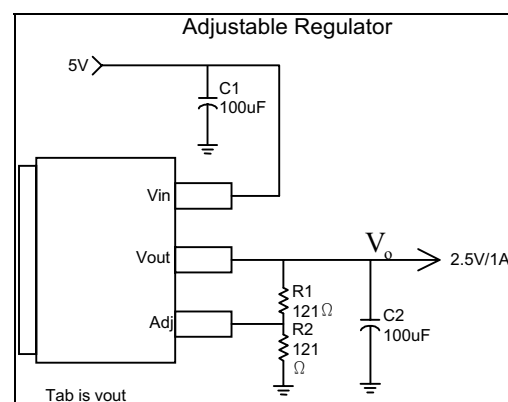
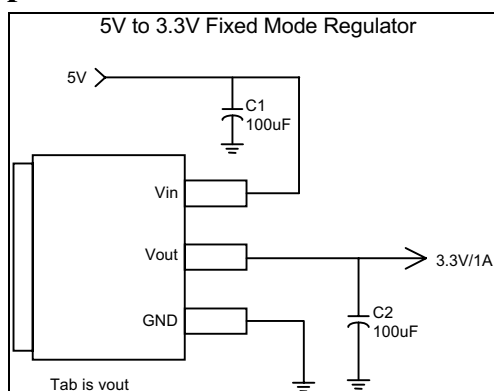

$$\text{Note: } V_o = V_{\text{REF}} * \left(1 + \frac{R_1}{R_2}\right)$$

This datasheet contains new product information. Analog Technology reserves the rights to modify the product specification without notice. No liability is assumed as a result of the use of this product. No rights under any patent accompany the sale of the product.

AP1117

1A Positive Low Dropout Regulator



■ Connection Diagram

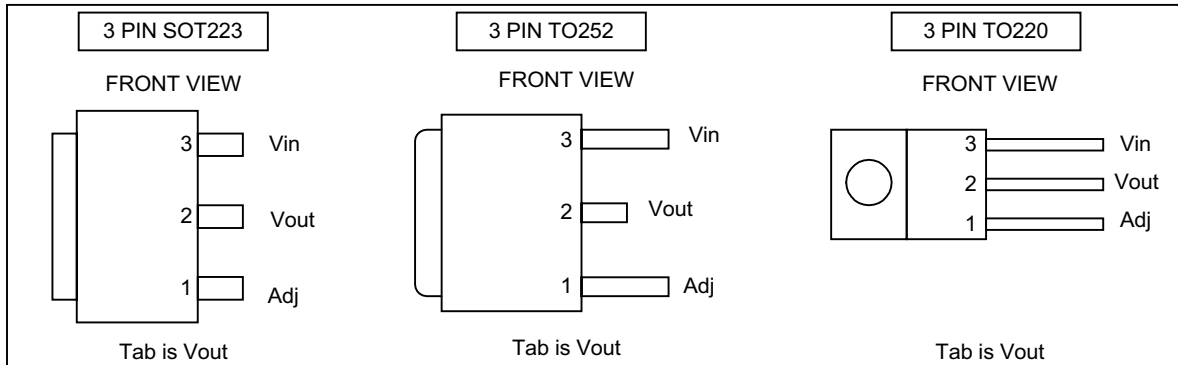

■ Pin Descriptions

Name	I/O	Pin#	Function
Adj	I	1	A resistor divider from this pin to the Vout pin and ground sets the output voltage.
Vout	O	2	The output of the regulator. A minimum of 10uF capacitor must be connected from this pin to ground to insure stability.
Vin	I	3	The input pin of regulator. Typically a large storage capacitor is connected from this pin to ground to insure that the input voltage does not sag below the minimum dropout voltage during the load transient response. This pin must always be 1.3V higher than Vout in order for the device to regulate properly.

AP1117

1A Positive Low Dropout Regulator



■ Absolute Maximum Ratings

DC Supply Voltage (Vin)	-0.3 to 12 V
Power Dissipation	Internally Limited
Storage Temperature	-65 to +150 °C
Operating Junction Temperature Range	0 to +150 °C

■ Electrical Characteristics (Under Operating Conditions)

Sym.	Parameter	Conditions (Notes)	Min.	Typ.	Max.	Unit
V _{REF}	Reference Voltage	AP1117-ADJ I _o =10mA, T _j =25°C, (V _{in} -V _{out})=1.35V	1.237	1.250	1.263	V
V _{out}	Output voltage	AP1117-3.3 I _o =10mA, T _j =25°C, V _{in} =5V	3.267	3.300	3.333	V
	Line Regulation	I _o =10mA, 1.35V < (V _{in} -V _{out}) < 12V			0.2	%
	Load Regulation	V _{in} =3.3V, V _{adj} =0, 10mA<I _o <1A			1	%
ΔV _o	Dropout Voltage	I _o =1A (ΔV _{out} = 1% V _{out})		1.25	1.30	V
	Current Limit	V _{in} =3.3V, dV _o =100mV	1.1			A
	Minimum Load Current	V _{in} =3.3V, V _{adj} =0V		5	10	mA
	Thermal Regulation	30mS Pulse, V _{in} -V _{out} =3v, I _o =1A		0.01	0.02	%W
	Ripple Rejection	F=120Hz, C _{out} =25uF Tan I _o =1A, V _{in} -V _{out} =3V		60	70	dB
I _{ADJ}	Adjust Pin Current	I _o =10mA, V _{in} -V _{out} =1.35V, T _j =25°C I _o =10mA, V _{in} -V _{out} =1.35V		55	100	μA
	Adjust Pin Current Change	I _o =10mA, V _{in} -V _{out} =1.35V, T _j =25°C		0.2	5	μA
	Temperature Stability	V _{in} =3.3V, V _{adj} =0V, I _o =10mA		0.5		%
θ _{JA}	Thermal Resistance Junction-to-Ambient (No heat sink ;No air flow)	SOT-223		117		°C/W
		TO-252		102		°C/W
		TO-220		85		°C/W
θ _{JC}	Thermal Resistance Junction-to-Case	SOT-223: Control Circuitry/Power Transistor		15		°C/W
		TO-252: Control Circuitry/Power Transistor		10		°C/W
		TO-220: Control Circuitry/Power Transistor		0.65/2.7		°C/W

■ Typical Performance Characteristics

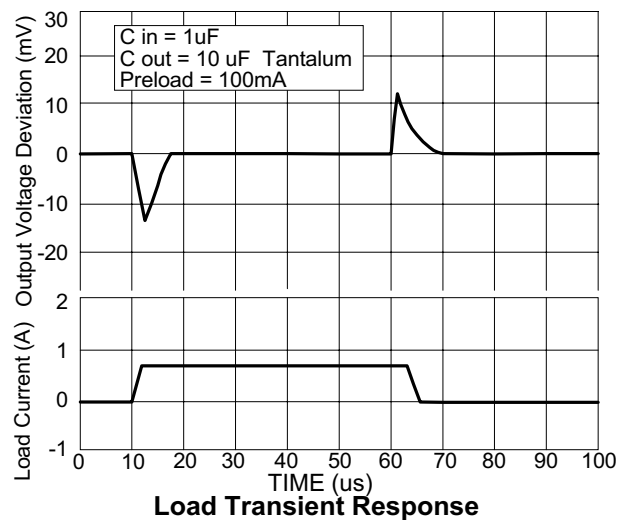
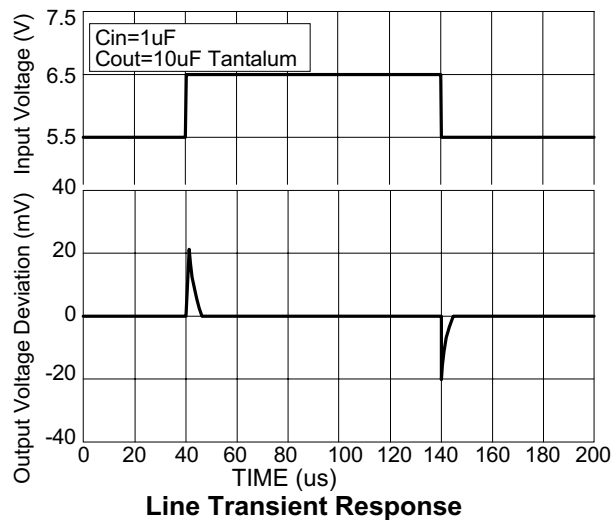
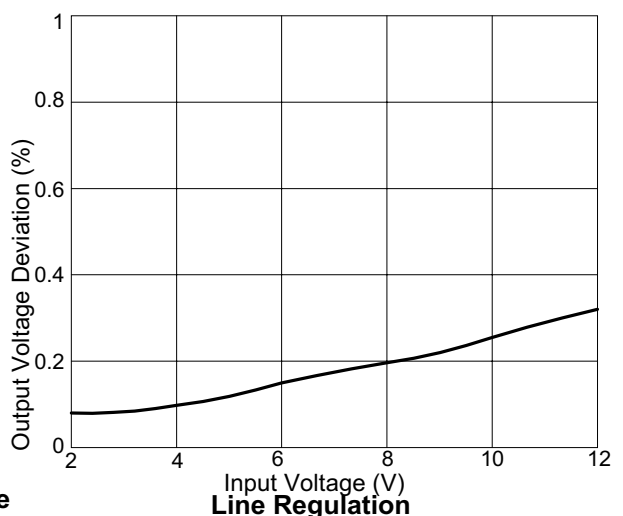
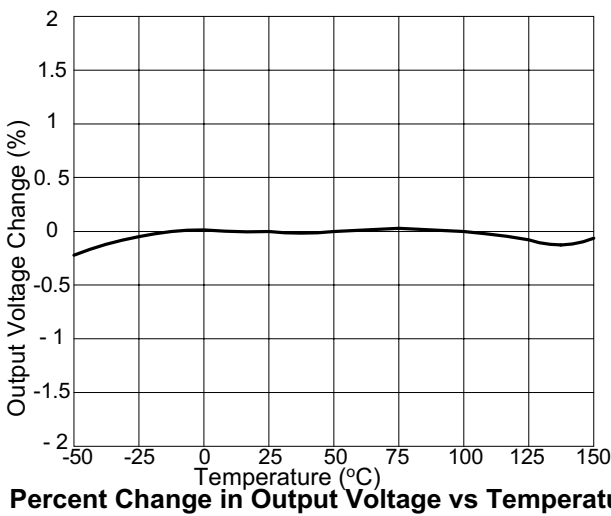
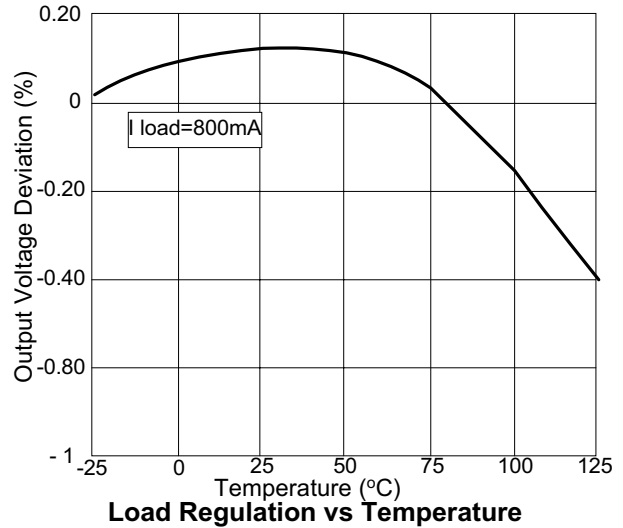
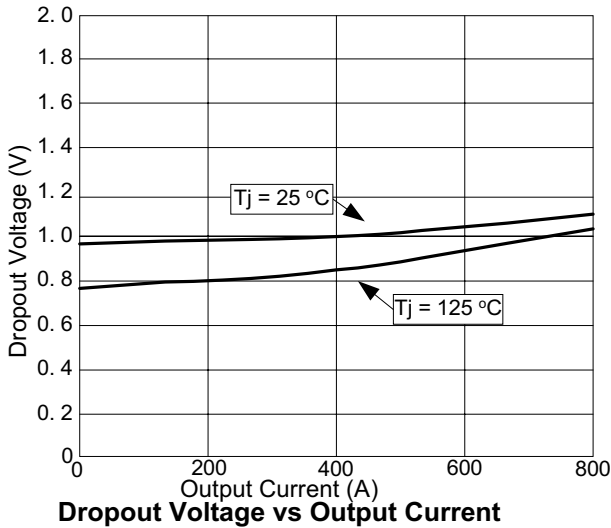

AP1117

1A Positive Low Dropout Regulator



■ Marking Information

(1) SOT223-3L

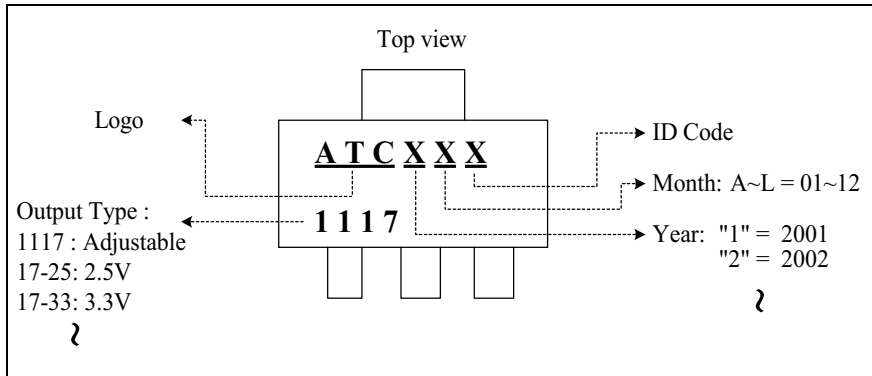

(2) TO252-3L

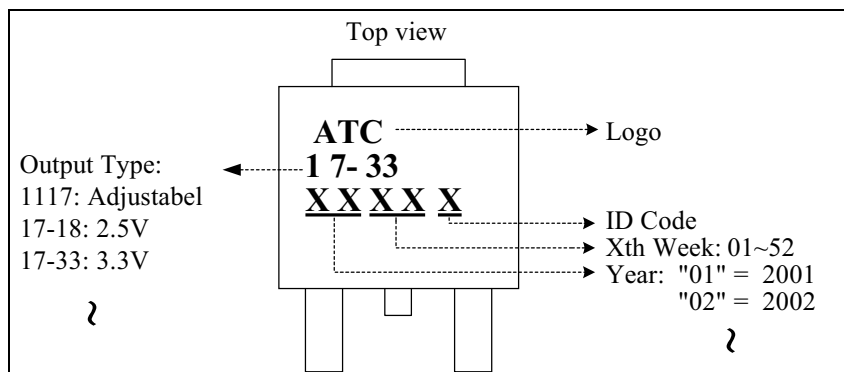

(3) TO220-3L

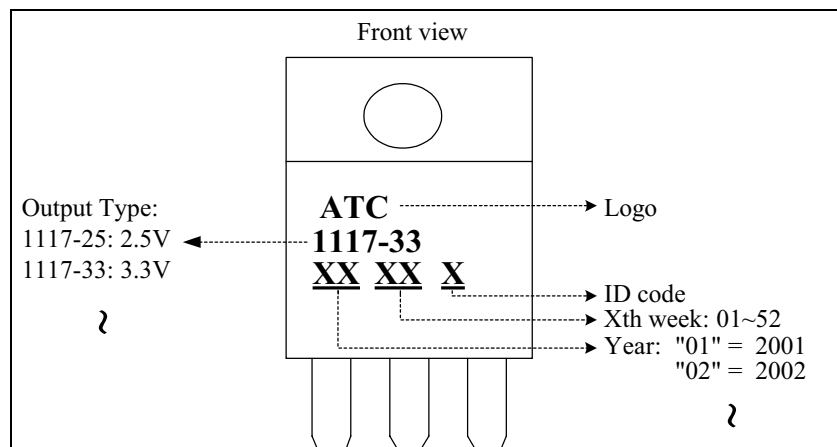

AP1117

1A Positive Low Dropout Regulator



■ Package Dimension

(1) SOT223-3L

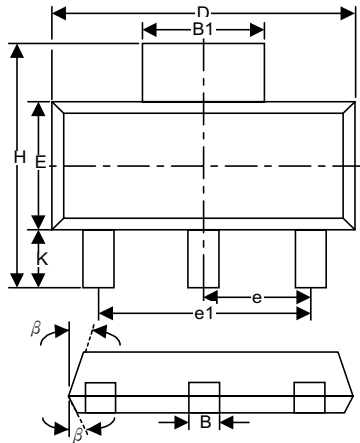

NOTES:
1. JEDEC OUTLINE: TO-261AA

Variations (Dimensions Show in mm)

SYMBOLS	MIN.	NOM.	MAX.
A	1.50	1.65	1.80
A1	0.02	0.05	0.08
B	0.60	0.70	0.80
B1	2.90	—	3.15(REF.)
c	0.28	0.30	0.32
D	6.30	6.50	6.70
E	3.30	3.50	3.70
e	2.3 BSC		
e1	4.6 BSC		
H	6.70	7.00	7.30
L	0.91	1.00	1.10
K	1.50	1.75	2.00
α	0°	5°	10°
β	—	13°	—

(2) TO252-3L

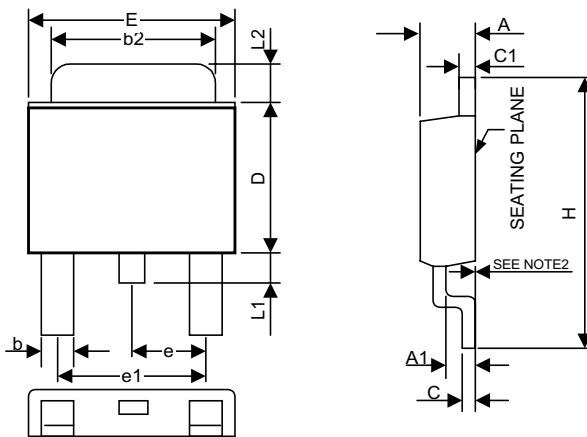

NOTES:
1. JEDEC OUTLINE: TO-252 AB
2 MILS SUGGESTED FOR POSITIVE CONTACT AT MOUNTING.

Variations (Dimensions Show in inch)

SYMBOLS	MIN.	MAX.
A	0.086	0.094
A1	0.040	0.050
b	0.024 TYP.	
b2	0.205	0.215
C	0.018	0.023
C1	0.018	0.023
D	0.210	0.220
E	0.250	0.265
e	0.090 BSC.	
e1	0.180 BSC.	
H	0.370	0.410
L	0.020	—
L1	0.025	0.040
L2	0.06	0.08

AP1117

1A Positive Low Dropout Regulator



(3) TO220-3L

Variations (Dimensions Show in inch)

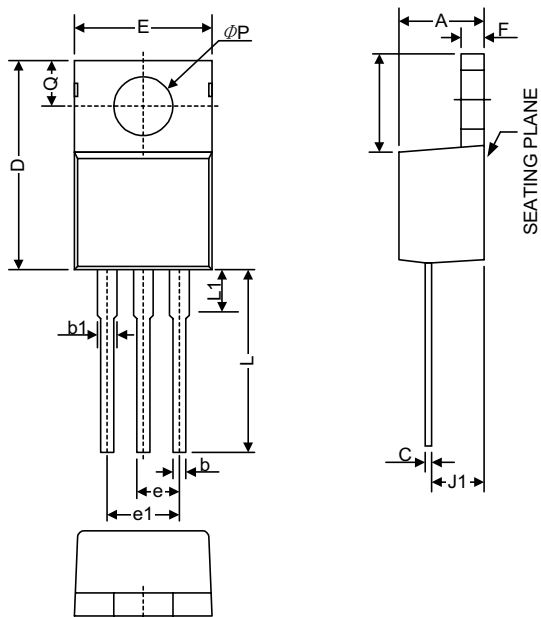

SYMBOLS	MIN.	MAX.
A	0.14	0.19
b1	0.045	0.07
b	0.02	0.045
C	0.012	0.045
D	0.56	0.65
E	0.38	0.42
e	0.09	0.11
e1	0.19	0.21
F	0.02	0.055
H1	0.23	0.27
J1	0.08	0.115
L	0.5	0.58
ϕP	0.139	0.161
Q	0.1	0.135