

IF_S-1W/ IF_D-1W Series

1W, FIXED INPUT ISOLATED & REGULATED
SINGLE OUTPUT MINIATURE SIP/DIP PACKAGE

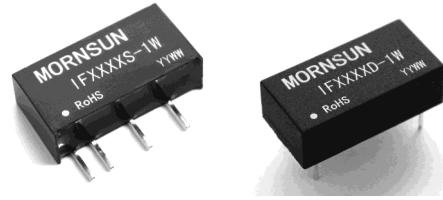

RoHS

FEATURES

- SIP/DIP Package
- 3KVDC Isolation
- Temperature Range: -40°C to +85°C
- Industry Standard Pinout
- No Heat sink Required
- No External Component Required
- PCB Mounting
- RoHS Compliance
- Short Circuit Protection

APPLICATIONS

The IF_S(D)-1W Series are specially designed for applications where a single power supply is highly isolated from the input power supply in a distributed power supply system on a circuit board.

These products apply to:

- 1) Where the voltage of the input power supply is fixed (voltage variation $\leq \pm 5\%$);
- 2) Where isolation is necessary between input and output (isolation voltage $\leq 3000\text{VDC}$);
- 3) Where the regulation of the output voltage and the output ripple and noise are demanding.

MODEL SELECTION

IF0505S-1W

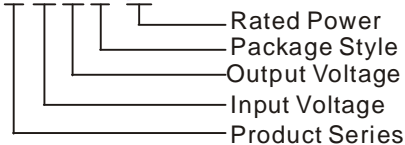

PRODUCT PROGRAM

Part Number	Input		Output			Efficiency (% Typ)	Package Style		
	Voltage (VDC)		Voltage (VDC)	Current (mA)					
	Nominal	Range		Max	Min				
IF0505S-W75	5	4.75-5.25	5	150	15	68	SIP		
IF0505S-1W			5	200	20	66	SIP		
IF0509S-1W			9	111	12	70	SIP		
IF0512S-1W			12	83	9	72	SIP		
IF0515S-1W			15	67	7	73	SIP		
IF0505D-W75			5	150	15	68	DIP		
IF0505D-1W			5	200	20	66	DIP		
IF0509D-1W			9	111	12	70	DIP		
IF0512D-1W			12	83	9	72	DIP		
IF0515D-1W			15	67	7	73	DIP		
IF1205S-W75			12	11.4-12.6	5	150	15	68	SIP
IF1205S-1W					5	200	20	67	SIP
IF1209S-1W*	9	111			12	71	SIP		
IF1212S-1W	12	83			9	73	SIP		
IF1215S-1W	15	67			7	74	SIP		
IF1205D-W75	5	150			15	68	DIP		
IF1205D-1W	5	200			20	67	DIP		
IF1209D-1W*	9	111			12	71	DIP		
IF1212D-1W	12	83			9	73	DIP		
IF1215D-1W	15	67			7	74	DIP		
IF2405S-W75	24	22.8-25.2			5	150	15	68	SIP
IF2405S-1W					5	200	20	67	SIP
IF2409S-1W*			9	111	12	72	SIP		
IF2412S-1W			12	83	9	73	SIP		
IF2415S-1W			15	67	7	74	SIP		
IF2405D-W75			5	150	15	68	DIP		
IF2405D-1W			5	200	20	67	DIP		
IF2409D-1W*			9	111	12	72	DIP		
IF2412D-1W			12	83	9	73	DIP		
IF2415D-1W			15	67	7	74	DIP		

Note: The IF_S(D)-W25 Series also available in our company. *Designing.

MORNSUN Science & Technology Co.,Ltd.

Address: No. 5, Kehui St. 1, Kehui development center, Science Ave., Guangzhou Science City, Luogang district, Guangzhou, P.R.China.

Tel: 86-20-28203030

Fax: 86-20-28203068

[Http://www.mornsun-power.com](http://www.mornsun-power.com)

ISOLATION SPECIFICATIONS

Item	Test condition	Min	Typ	Max	Units
Isolation voltage	Tested for 1 minute	3000			VDC
Isolation resistance	Test at 500VDC	1000			MΩ

OUTPUT SPECIFICATIONS

Item	Test condition	Min	Typ	Max	Units
Output power		0.1		1	W
Line regulation	For Vin change of ±5%			±0.25	%
Load regulation	10% to 100% full load			±1	
Output voltage accuracy	100% full load			±3	
Temperature drift	100% full load			0.03	%/°C
Output ripple*	20MHz bandwidth		10	20	mVp-p
Output noise*	20MHz bandwidth		50	100	
Switching frequency	Full load, nominal input voltage		100		KHz

*Test ripple and noise by "parallel cable" method. See detailed operation instructions at Testing of Power Converter section, application notes.

COMMON SPECIFICATIONS

Item	Test condition	Min	Typ	Max	Units
Storage humidity range				95	%
No-load power consumption			10		
Storage humidity range		-55		125	°C
Operating temp. range		-40		85	
Temp. rise at full load			15	25	
Lead temperature	1.5mm from case for 10 seconds			300	
Short circuit protection	IFXX05S/D-1W*			1	S
	Others	Continuous			
Cooling		Free air convection			
Case material		Plastic (UL94-V0)			
MTBF		3500			K hours

*Supply voltage must be discontinued at the end of short circuit duration.

APPLICATION NOTE

① Requirement On Output Load

To ensure this module can operate efficiently and reliably, a minimum load is specified for this kind of DC/DC converter in addition to a maximum load (namely full load). During operation, make sure the specified range of input voltage is not exceeded, the minimum output load **could not be less than 10% of the full load**. If the actual output power is very small, please connect a resistor with proper resistance at the output end in parallel to increase the load, or use our company's products with a lower rated output power (IF_S(D) -W25 Series).

② Filtering

In some circuits which are sensitive to noise and ripple, a filtering capacitor may be added to the DC/DC output end and input end to reduce the noise and ripple. However, the capacitance of the output filter capacitor must proper. If the capacitance is too big, a startup problem might arise. For every channel of output, providing the safe and reliable operation is ensured, the greatest capacitance of its filter capacitor refer to (Table 1).

To get an extremely low ripple, an "LC" filtering network may be connected to the input and output ends of the DC/DC converter, which may produce a more significant filtering effect. It should also be noted that the inductance and the frequency of the "LC" filtering network should be staggered with the DC/DC frequency to avoid mutual interference (Figure 1).

③ Overload Protection

Under normal operating conditions, the output circuit of these products has no protection against over-current. The simplest method is to connect a self-recovery fuse in series at the input end or add a circuit breaker to the circuit.

④ When the environment temperature is higher than 71°C, the product output power should be less than 60% of the rated power.

⑤ No parallel connection or plug and play.

The copyright and authority for the interpretation of the products are reserved by MORNSUN

TYPICAL CHARECTERISTICS

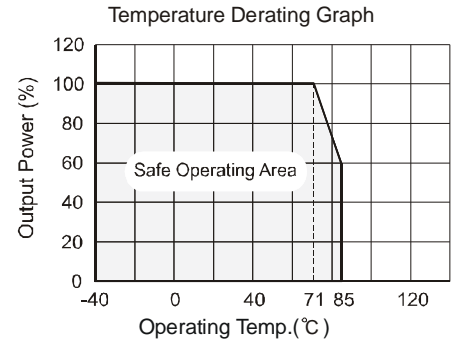

RECOMMENDED CIRCUIT

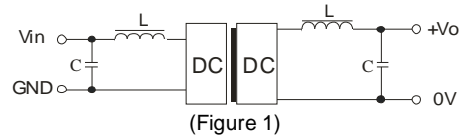

EXTERNAL CAPACITOR TABLE (TABLE 1)

Vin (VDC)	Cin (μF)	Vout (VDC)	Cout (μF)
5	4.7	5	10
12	2.2	9	4.7
24	1	12	2.2
-	-	15	1

It's not recommended to connect any external capacitor in the application field with less than 0.5 watt output.

OUTLINE DIMENSIONS & RECOMMENDED FOOTPRINT

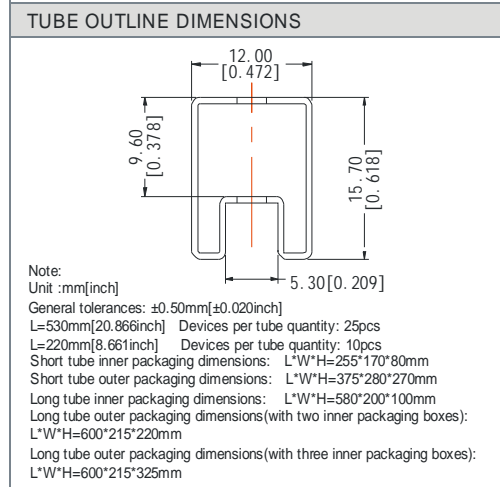
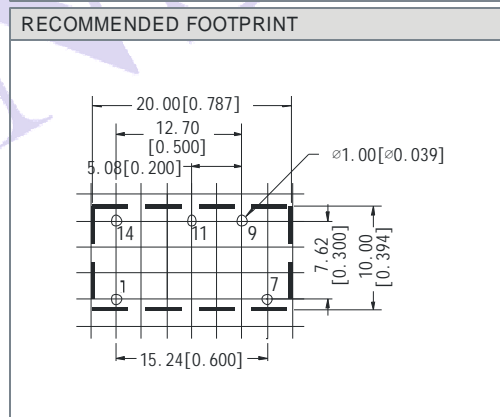
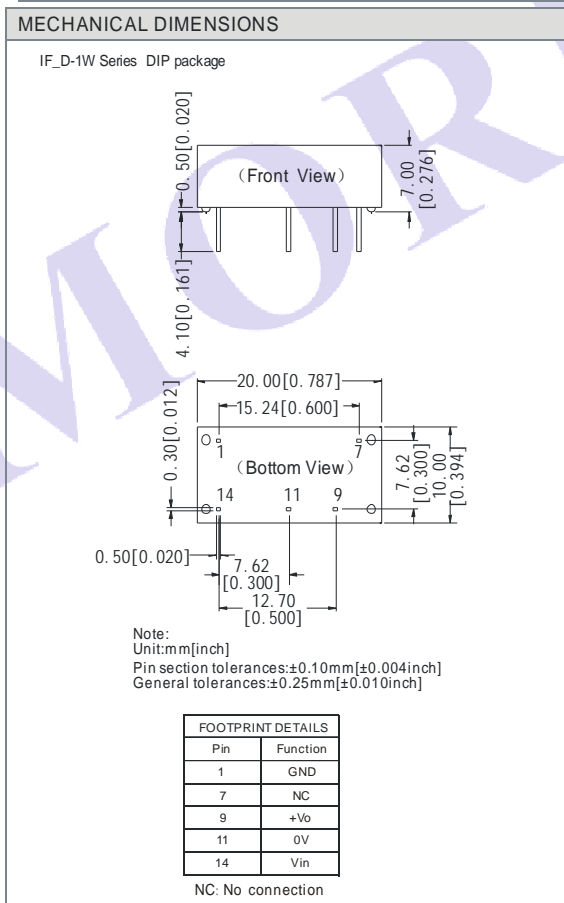
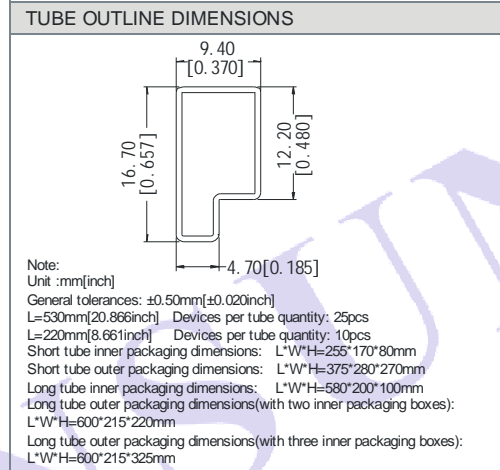
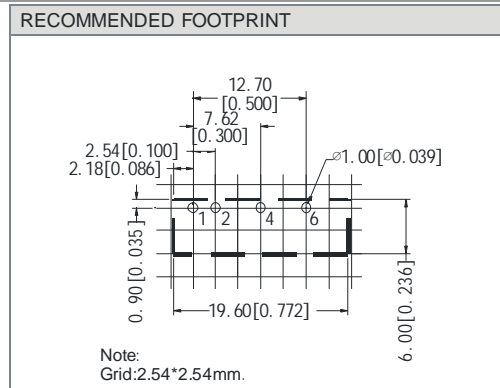
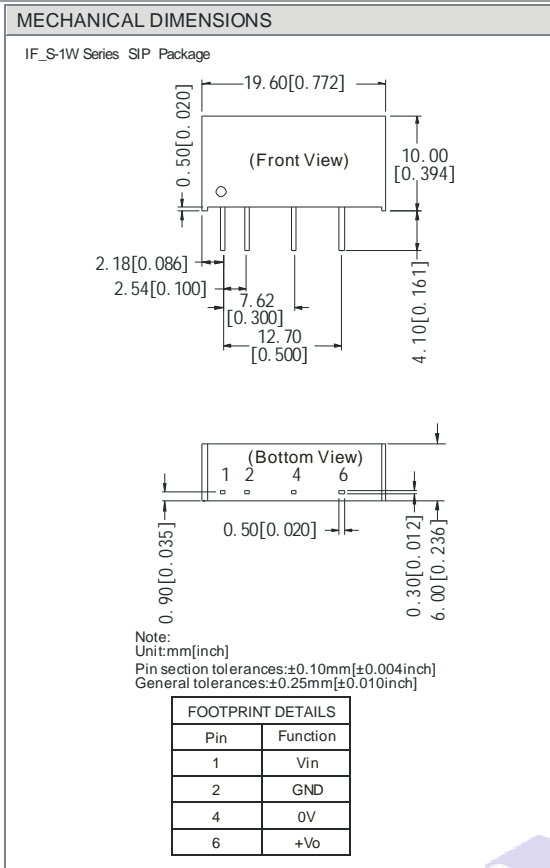

Note:

1. All specifications measured at TA=25°C, humidity<75%, nominal input voltage and rated output load unless otherwise specified.
2. See below recommended circuits for more details.
3. Operation under minimum load will not damage the converter; However, they may not meet all specification listed, and that will reduce the life of product.