

# Motor Driver Monolithic IC MM1036

## Outline

This is a motor driver IC developed for video movie use. It has four modes : open, forward, reverse and brake. It can be used with power supply voltages of 4~16V.

## Features

1. Operating voltage range 4~16V
2. Current consumption during standby 2μA max
3. Built-in 2.2V stable power supply
4. Can operate on single power supply
5. Control pins D0 and D1 have TTL interface
6. Built-in thermal shutdown
7. Built-in counter-electromotive clamp diode

## Package

SOP-8B (MM1036XF)

## Applications

Video movies (auto-focus, zoom)

## Equivalent Circuit Diagram

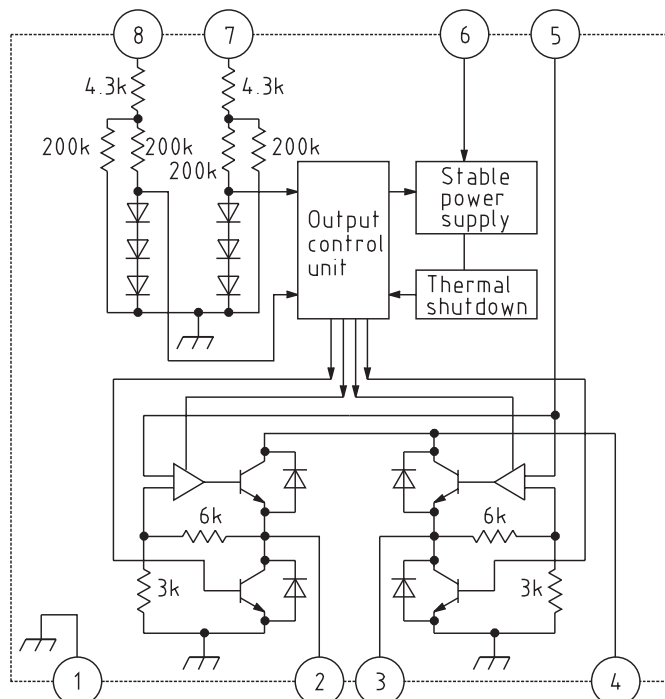

## Pin Description

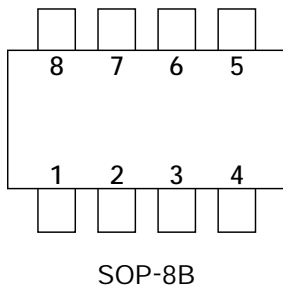

Pin no.	Pin name	Function
1	GND	GND
2	M0	M0 output pin
3	M1	M1 output pin
4	V <sub>CC</sub>	V <sub>CC</sub>
5	V <sub>C</sub>	Output voltage control
6	V <sub>REF</sub>	Stable power supply
7	D0	D0 control pin
8	D1	D1 control pin

## Mode Settings

D0	D1	Mode	M0	M1
L	L	Open	L	L
H	L	Forward	H	L
L	H	Reverse	L	H
H	H	Brake	L	L

## Absolute Maximum Ratings (Ta=25°C)

Item	Symbol	Ratings	Units	Conditions
Storage temperature	T <sub>STG</sub>	-40~+125	°C	
Operating temperature	T <sub>OPR</sub>	-15~+75	°C	
Power supply voltage	V <sub>CC</sub>	20	V	
Stable power supply	Pd	350 *1	mW	
		470 *2		
Output current	I <sub>O</sub>	100 *3	mA	
D0, D1 applied voltages	V <sub>DIN</sub>	-0.3~+7.0	V	V <sub>DIN</sub> ≤ V <sub>CC</sub> +0.7
Voltage applied to VC	V <sub>CIN</sub>	-0.3~+7.0	V	

Notes :

\*1 Loss tolerance for unit of C

\*2 Loss tolerance when mounted on 20×38×1 [mm] glass epoxy board

\*3 Within 100ms [Refer to materials]

**Electrical Characteristics** (Except where noted otherwise,  $T_a=25^\circ\text{C}$ ,  $V_{CC}=6.0\text{V}$ ,  $V_M=4.5\text{V}$ )

Item	Symbol	Measurement conditions	Min.	Typ.	Max.	Units
Operating voltage	$V_{CC}$		4.0		16	V
Consumption current 1	$I_{CC1}$	$VD0, VD1=0\text{V}, V_{CC}=16\text{V}$			2.0	$\mu\text{A}$
Consumption current 2	$I_{CC2}$	$VD0, VD1=2.4\text{V}, V_{CC}=16\text{V}$		9.5	15	mA
Output saturation voltage (L)	$V_{sat}$	$I_M=60\text{mA}$			250	mV
Output voltage (L) Load fluctuation 1	$L_{reg1}$ (L)	$I_M=10\sim 60\text{mA}$			200	mV
Output voltage (L) Load fluctuation 2	$L_{reg2}$ (L)	$I_M=10\sim 100\text{mA}$			350	mV
M0, M1 I/O ratio	K	$K=V_M/V_C, I_M=0\text{mA}$	2.85	3.00	3.15	
Output voltage range	$V_M$	$I_M=-60\text{mA}$	2.0		$V_{CC}-1.1$	V
Output voltage (H) Load fluctuation 1	$L_{reg1}$ (H)	$I_M=0\sim 65\text{mA}$			100	mV
Output voltage (H) Load fluctuation 2	$L_{reg2}$ (H)	$I_M=-10\sim 100\text{mA}$			200	mV
Reference voltage	$V_{ref}$	$I_{ref}=1\text{mA}$	2.10	2.20	2.30	V
D0, D1 threshold voltages	$V_{TH}$		0.6		2.4	V
D0, D1 input currents	$I_D$	$VD0, VD1=5\text{V}$		40	100	$\mu\text{A}$
Thermal shutdown operating temperature				150		$^\circ\text{C}$
Thermal shutdown hysteresis temperature				50		$^\circ\text{C}$

■ Maximum output current-Input/output difference voltage characteristics ( $25^\circ\text{C}$ )

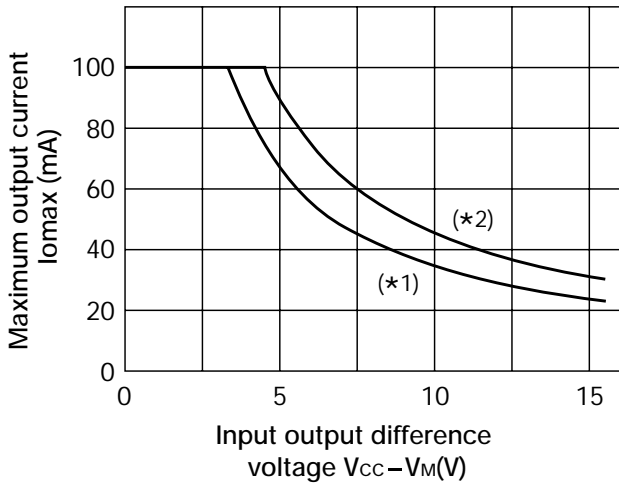

Note : Calculate from  $I_{o\ max.} = P_d / (V_{CC} - V_M + 0.3)$   
 \*1 Unit : IC  
 \*2 When mounted on glass epoxy board 20X38X1 [mm]

■ Loss tolerance-Temperature characteristics

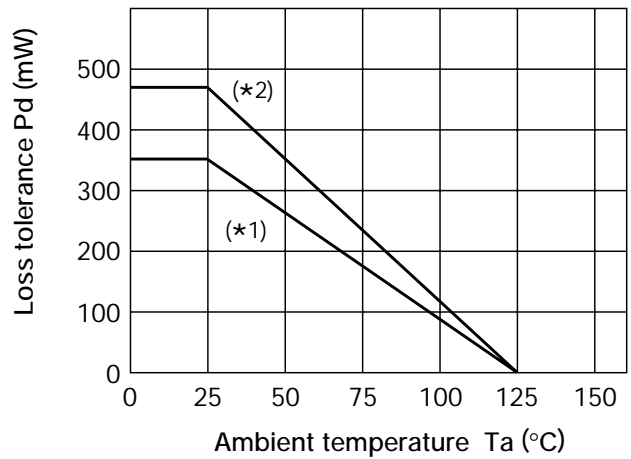

\*1 Unit : IC  
 \*2 When mounted on glass epoxy board 20X38X1 [mm]

**Measuring Circuit**

